

Using LEDs With Onboard Thermistors

Calibrating Systems With a Thermal Feedback Mechanism

Author:
Paul Sims

October 2024

Table of Contents

Overview	1
1.0 Thermal Concepts.....	2
Thermal Resistance Definitions.....	2
Thermal Resistance Parameters.....	3
Thermal Characterization Parameters.....	3
2.0 LED Calibration Procedure to Determine $R_{th-jref}$	5
3.0 Data from the Luminus Test Lab	7
4.0 K Factor Determination.....	8
Linear Vs. Non-Linear Behavior	9
Non-Linearities Due to LED Device Physics	9
Non-Linearities Due to the Pulse Process	10
5.0 Thermistors	12
6.0 Conclusion.....	13
7.0 Resources.....	13
8.0 Glossary	13
9.0 References	14

Overview

Luminus offers a range of high-power LED packages that come with built-in thermistors, which act as temperature sensors within the package. These thermistors are crucial for providing feedback to control the power delivered to the LED and thus preventing the junction from overheating. This power supply control approach is called thermal foldback [1]. An example of a Luminus component with an integrated thermistor is shown in Figure 1. Additionally, an LED system designer can incorporate a thermal sensing element in any system by placing one on the PCB (printed circuit board). This White Paper discusses how to design, select materials for, test, and calibrate systems with temperature feedback elements to achieve the desired product performance and lifetime.

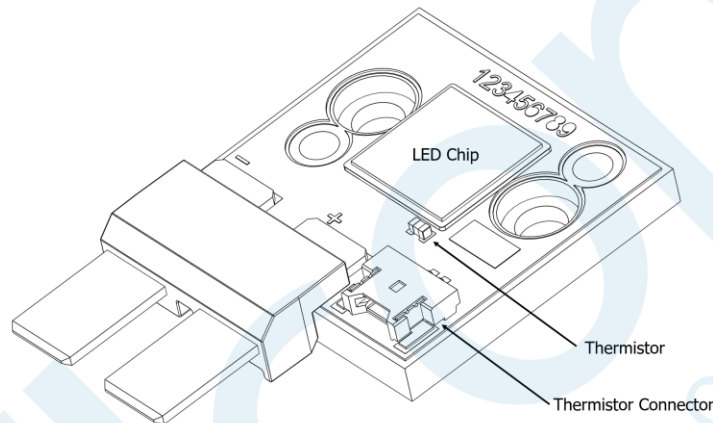

Figure 1. Typical Luminus coreboard layout illustrating the placement of the LED chip, the thermistor, and the thermistor connector.

The two key parameters of interest are the LED thermal resistance (R_{th-jc}) and the LED-to-thermistor characterization parameter ($R_{th-jref}$). While these parameters have the same units and are used similarly, there are fundamental differences in the measurements and physics involved. The values of R_{th-jc} and $R_{th-jref}$ can be used to determine temperatures (Figure 2) in LED design and in active thermal control. The value of R_{th-jc} is an invariant measure of the LED component, while the value of $R_{th-jref}$ depends on the design of the cooling system on which the LED is mounted. This value changes if cooling components are modified, thus understanding how to calibrate for new values of $R_{th-jref}$ is needed.

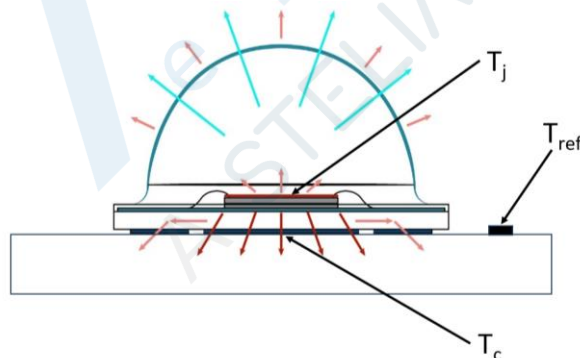

Figure 2. Temperature labeling conventions used in this document following JESD-51-14 [2]. The thermal resistance between T_j and T_c (the LED solder point or bottom of a coreboard) are characterized by the LED R_{th-jc} value. The thermal characterization parameter, $R_{th-jref}$, is based on the temperature difference between T_j and the particular point where T_{ref} is measured in the cooling system.

1.0 Thermal Concepts

Thermal Resistance Definitions

Thermal analysis literature uses a wide variety of symbols and subscripts such as [3] and [4]. The symbols defined below are used in this paper for the main concepts discussed.

- **Thermal Resistance, R_{th-jc}** , measured in °C/W – single path heat flow from the junction to the solder point (case temperature) of an LED.
- **Thermal Characterization Parameter, $R_{th-jref}$** , °C/W – thermal resistance for multi-path heat flow between two arbitrary points. In this case, the LED junction and a reference point. Some of these heat flow paths do not go through the reference point.

Thermal resistance measures the temperature difference between two isothermal surfaces as a function of the rate of heat flow between them. This concept assumes that the same amount of heat passing through the first surface also goes through the second without any heat being stored or “leaking” to other elements. Thermal resistance for a component is defined as:

$$R_{th-jc} = \frac{T_j - T_c}{P} ; T_j = R_{th-jc} \cdot P + T_c$$

$$P = I_f \cdot V_f$$

where T_j is the LED junction temperature, T_c is the case temperature (cooler surface at the LED solder point), and P is the applied power.

LED applications distinguish between two types of thermal resistance: electronic and real [5].

1. **Electronic Thermal Resistance $R_{th-elec}$** : This considers the electrical input power, which is the voltage multiplied by the current supplied to the LED.
2. **Real Thermal Resistance $R_{th-real}$** : This considers the thermal input power, which is the voltage multiplied by the current supplied to the LED excluding the light power emitted. The relationship is given by:

$$R_{th-real} = \frac{R_{th-electrical}}{1 - \eta}$$

where η is the efficiency of the LED. The $R_{th-real}$ value is based on the thermal power input with the optical power removed so is solely based on the LED package materials and geometry.

A “K-factor technique” can be used to calculate T_j from measured LED voltages. The thermal measurement employed for LED systems involves experimentally determining the LED K factor (dT/dV) at different temperatures and injection currents. Empirical K-factor functions can be used to determine $T_j = f(V_f)$ for specific drive currents. This will be discussed further in Section 4.

Thermal Resistance Parameters

In LED systems, there are only two true thermal resistances that can be modeled as a two-node thermal element. These are the R_{th-jc} of the LED and the R_{th-jA} for the junction to ambient temperature. For these, all heat leaving the junction, the first point, eventually arrives at or passes through the other point—either ambient or LED case point, respectively.

Measuring LED R_{th-jc} values uses a well-established technique, the "Transient Dual Interface Measurement" (TDIM) method, as per JESD51-14 [2]. Luminus uses a T3Ster® Thermal Transient Tester to measure LED thermal resistance.

Thermal Characterization Parameters

Thermal characterization parameters differ from thermal resistance parameters because the heat is not simply flowing between two temperature nodes. For the $R_{th-jref}$ parameter, there is heat flow through the reference point position that results in a temperature difference between T_j and T_{ref} . This (T_{ref}) is an intermediate point, and heat continues to flow with multiple paths towards the ambient. The heat flow in the rest of the thermal system affects T_{ref} by changing the amount of heat going through the reference node. Heat starts at the LED junction and follows a 3D path. This means the thermal characterization parameter ($R_{th-jref}$) is dependent on the specific cooling system design, which affects the 3D heat flow path. Not all of the heat flows through the reference point so a two-node thermal resistance model is not applicable.

What do we mean by “K-Factor”?

In this White Paper, the term K-factor is used solely to refer to the measured dT/dV slope. When voltage is plotted on the x-axis of a graph and temperature on the y-axis, the K-factor is the slope of the data.

Note that “K-factor” is also used in the LED industry to refer to multiple concepts.

Since it is an intermediate point, the junction-to-reference thermal characterization parameter is influenced by multiple factors that can change the thermal path as it goes through the reference point, including:

- Diffusion from nearby heated components
- Proximity to different materials
- Design and size of the test setup
- Power levels and airflow
- Component placement
- The thermal characteristics of balance of system (BOS) components such as a PCB, a thermal interface material (TIM), and the heatsink.

Due to these variables, components tested under different cooling conditions and thermal stack configurations will have a range of thermal characterization parameters. Figure 3 shows this conceptually and Figure 4 shows an example of a system level thermal circuit with three BOS layers considered.

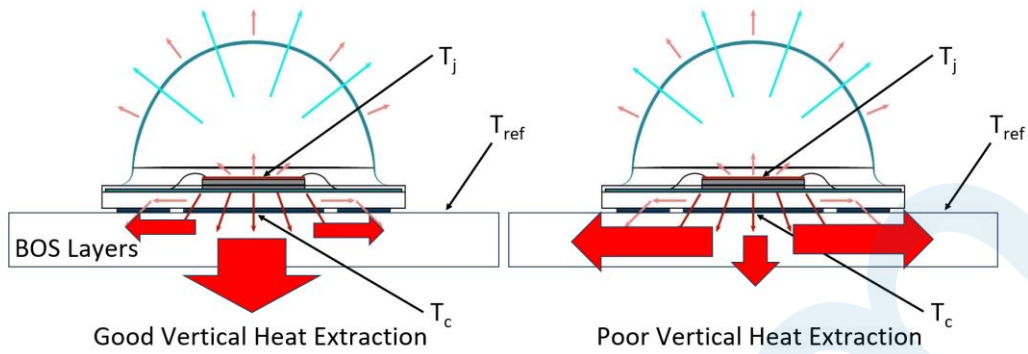

Figure 3. Visualization of differences between a thermal system with good vertical heat extraction compared to one with poor vertical heat extraction. In the poor case, the heat spreads more before going down towards the ambient. In the poor case, the temperatures of T_j and T_{ref} are both higher for the same input power due to thermal choking in the balance of system (BOS) layers.

LEDs are designed to have good vertical heat extraction and the R_{th-jc} values are known from thermal characterization tests. The vertical thermal extraction of the balance of the system elements depend on individual $R_{th-layer}$ values for each layer. Systems with poor vertical heat extraction exhibit more horizontal heat flow.

Figure 4 illustrates a thermal circuit in a thermal system, highlighting distributed horizontal and vertical thermal resistances. This is a two-dimensional representation, but it is really three dimensional. The actual values of the discretized thermal resistances are not necessarily the same for each element shown; they depend on geometry and materials. The measured temperature difference between the LED junction and a reference point is used to calculate $R_{th-jref}$. R_{th-jc} is known from device characterization.

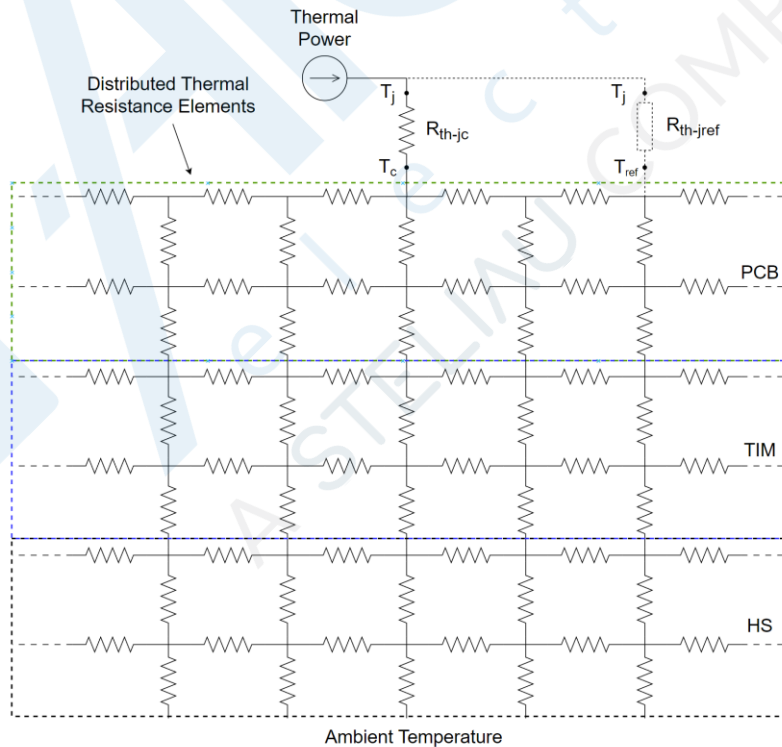

Figure 4. Distributed net visualization of a thermal system showing vertical and horizontal elements.

2.0 LED Calibration Procedure to Determine $R_{th-jref}$

To accurately determine the junction temperature of an LED under normal operation, the recommended approach is to measure forward voltage in-situ following an oven-based K-factor calibration process. The equipment for the K-factor calibration procedure includes a power supply with pulsing capability, and an oven that can maintain a consistent isothermal environment. Empirical K-factor functions can be derived to determine $T_j = f(V_f)$ for specific drive currents. This requires different strategies depending on the size and form factor of the test article. Small single LEDs are relatively simple to calibrate but larger multi-LED systems may require special designs.

The calibration process is as follows:

- 1. Setup:** Mount the LED onto the designated PCB and a thermal mass. The thermal mass could be a passive heatsink or simply an aluminum block. The purpose is to stabilize the temperature during the test. This assembly is referred to as the Device Under Test (DUT).
- 2. Temperature Stabilization:** Place the DUT inside an oven and set the test temperature to the initial expected junction temperature. Allow the temperature within the oven to stabilize so that everything is isothermal.
- 3. K-factor Measurements:** Use a programmable power supply to pulse the DUT at different current levels and measure the voltage for each current. Adjust the oven to the next test temperature and repeat the current-voltage measurements. At the end of this process you will have a set of T-V curves for each current that can be correlated to the junction temperature of the DUT.
- 4. Data Analysis:** Plot the measured values and verify that the results display a reasonably smooth relationship with temperature at each current setting. Figure 5 (next page) shows a good result. Use these datasets to derive the K-factor equations for each current level. These are generally linear but might be quadratic if a large temperature range is measured.
- 5. Real-World Application:** Install the calibrated LED(s) in your light fixture and operate using the design intent power supply. For a single LED such as a coreboard, it is relatively simple to monitor the voltage. For more complex PCBs with multiple LEDs, special test pads may be needed. In a multiple LED system, calibrating the entire string voltage may be easier than monitoring a single LED.
- 6. Final Measurements:** Once the light fixture temperature has stabilized, measure the calibrated LED voltage and the thermistor resistance. Use the thermistor datasheet (Section 5) to ascertain the thermistor's temperature and the relevant K-factor equation from step 4 to determine the junction temperature.
- 7. Thermal Characterization Parameter Calculation:** Calculate $R_{th-jref}$ using the formula:

$$R_{th-jref} = \frac{T_j - T_{ref}}{P}$$

where P is the power applied to the LED, T_j is the junction temperature determined by the calibration curves developed in step 4, and T_{ref} is the reference temperature measured by the thermistor.

8. Verification: The T_{j-ref} value should be applicable for the same DUT setup for similar operating current and temperature conditions. Verify within a range of expected conditions to ensure accuracy. Fan-cooled heatsinks and water-cooled systems are expected to be more constant, while passive heatsinks will vary more due to nonlinearities in convective heat extraction at different power levels.

This structured approach ensures precise calibration and measurement of the LED's thermal characteristics under operational conditions.

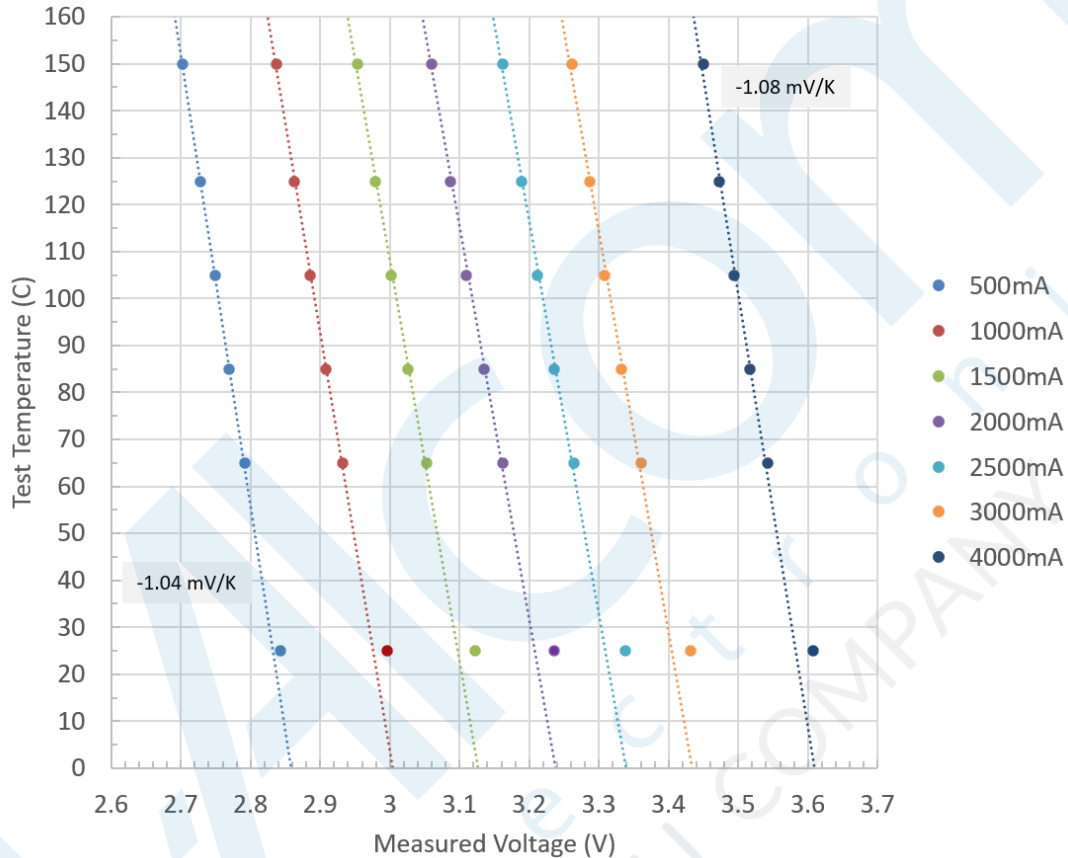

Figure 5. Example of a K factor plot for measured data for a 1 mm^2 Luminus blue LED, showing excellent linearity between $65 \text{ }^\circ\text{C}$ and $150 \text{ }^\circ\text{C}$. Nonlinear behavior at lower temperatures is typical (discussed in Section 4).

3.0 Data from the Luminus Test Lab

Luminus includes the value of $R_{th-jref}$ in the datasheet for components that have onboard thermistors. It is crucial to understand that this value is based on specific thermal design and test conditions outlined in the datasheet and may vary with significant changes in the real-world fixture thermal design. In such instances, it becomes necessary to determine the $R_{th-jref}$ value experimentally to ensure accurate thermal management.

In Figure 6, the experimental setup to determine $R_{th-jref}$ for a Luminus coreboard product is shown. In Table 1, the results for a measurement using three different TIMs are shown.

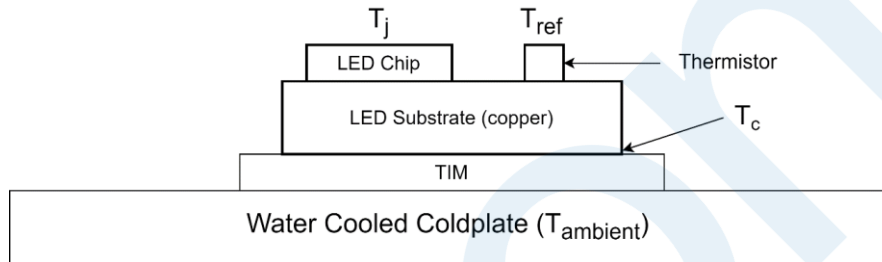

Figure 6. Schematic of the experimental configuration to determine $R_{th-jref}$ in the Luminus Lab test fixture. T_j is measured using the K-factor technique and T_{ref} is determined by measuring the resistance of the thermistor and calculating the temperature according to the thermistor datasheet (Section 5).

Luminus Labs ran an experiment with three different TIM’s to illustrate their impact on R_{th-ref} .

These TIMs are:

- BT - Double sided thermal tape, which is a relatively poor heat conductor.
- EG - eGRAF 1205 - This is the standard material Luminus uses for thermal testing (a good thermal conductor).
- SC - Thermal grease (another good thermal conductor).

This LED has been characterized using the TDIM technique and the component $R_{th-jc, real}$ value was determined to be $0.71 \text{ } ^\circ\text{C/W}$. This value is used to calculate T_c in the table below. The temperatures for the BT TIM case are higher and, in this case, the $R_{th-jref}$ values are also higher. We always expect higher temperatures for systems that contain layers with poor thermal conductivity but the calculated value of $R_{th-jref}$ depends on geometry as well, so this result is less certain.

Table 1. Test Data and Calculated $R_{th-jref}$ for Three Different TIMs

Parameter	BT	EG	SC
$T_j \text{ (} ^\circ\text{C)}$	121.2	66.0	61.9
$T_c \text{ (} ^\circ\text{C)}$	92.7	39.4	34.7
$T_{ref} \text{ (} ^\circ\text{C)}$	72.7	34.8	32.8
$T_{amb} \text{ (} ^\circ\text{C)}$	25.0	25.0	25.0
P (W)	57.0	57.0	57.0
WPE (%)	30.3	34.4	34.4
$R_{th-jref,electrical} \text{ (} ^\circ\text{C/W)}$	0.85	0.55	0.50
$R_{th-jref,real} \text{ (} ^\circ\text{C/W)}$	1.22	0.83	0.76
$R_{th-jambient} \text{ (} ^\circ\text{C/W)}$	1.68	0.72	0.63

4.0 K Factor Determination

Semiconductor devices like LEDs usually show a linear or near-linear relationship between forward voltage and temperature across varying current levels. This method, often known as the "diode-forward-drop" method, typically uses the forward voltage drop across a junction as the temperature-sensitive parameter (TSP). The calibration process involves calculating the K factor ($^{\circ}\text{C}/\text{V}$) for each device, as illustrated in Figure 7. This technique is elaborated in EIA/JEDEC Standard No. 51-1 [6] and has been discussed in more detail in Section 2. It is also beneficial to compute the inverse of the K factor in $\text{mV}/^{\circ}\text{C}$. This value should be a few $\text{mV}/^{\circ}\text{C}$ for a single junction measurement.

Both TDIM and system level junction temperatures can be determined by using dT/dV , the K factor. The temperature difference equation is given by

$$\Delta T_j(\Delta V_f) = K \cdot \Delta V_f$$

where K is the dT/dV slope of collected data. If a regression line is calculated, the y-intercept is available to do absolute T_j calculations. This equation is shown in Figure 7 for a linear regression which can be used to directly calculate the junction temperature of this LED.

In the TDIM method used to measure LED components [2], the current of a temperature stabilized LED is dropped to a low value that does not appreciably heat the LED junction while the change in voltage with the cooling rate is observed with high-speed electronics in the T3ster apparatus. For system level measurements, the pulse method discussed in Section 3 is recommended for the calibration data collection so that a constant current at real-world levels can be used after calibration.

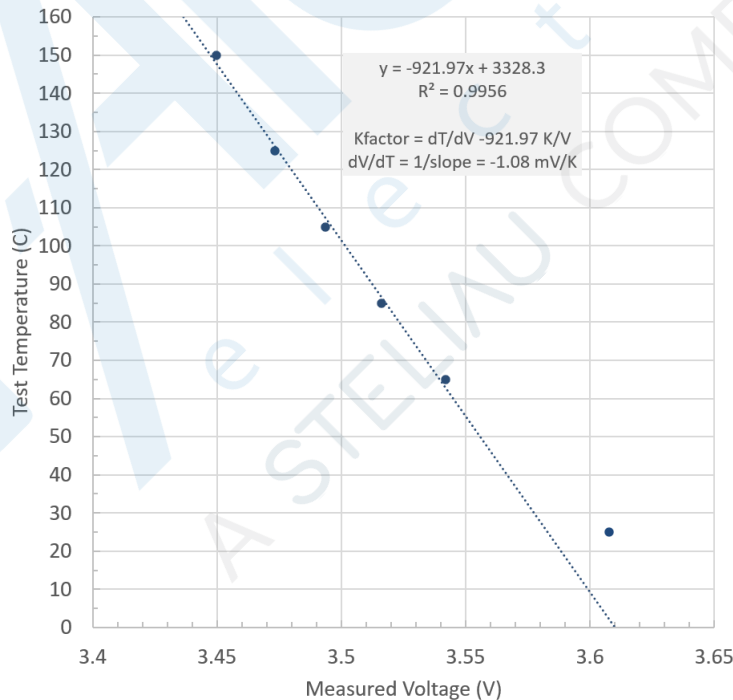

Figure 7. Illustration of K-factor calculation for a 1 mm^2 Luminus blue LED.

Linear Vs. Non-Linear Behavior

Ideally, a K-factor result plot will have a wide range of linear behavior for the temperatures and currents of interest such as the example shown in Figure 8. Linearity does not always occur and we will briefly discuss some symptoms and causes of non-linear results. These results can be either due to device physics or due to measurement equipment constraints.

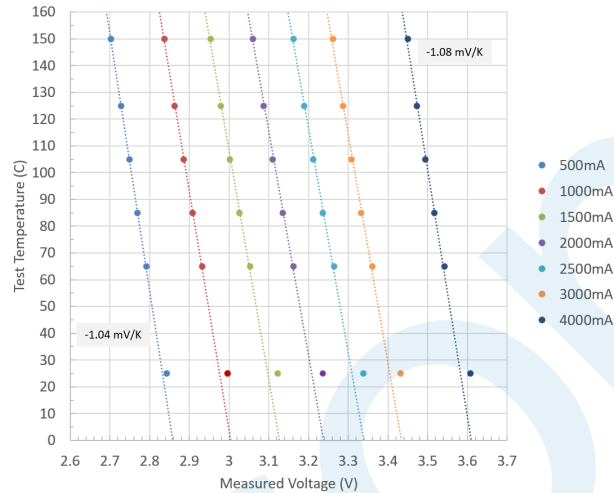

Figure 8. K factor plot (previously shown in Figure 5) for measured data for a 1 mm² Luminus blue LED, showing excellent linearity between 65 °C and 150 °C. Nonlinear behavior at lower temperatures is typical and this regression is from 65 °C to 150 °C.

Non-Linearities Due to LED Device Physics

The 25 °C points are excluded from the linear fit in Figure 7 and Figure 8 because these data points are subject to the onset of typical low-temperature nonlinear behavior. See Figure 9 for an example of low-temperature curvature for a red LED. Other types of LEDs have similar low-temperature nonlinearities [1]. Nonlinear behavior is expected at lower temperatures and if one wants to characterize a wide temperature range, higher order polynomials are needed to fit the data.

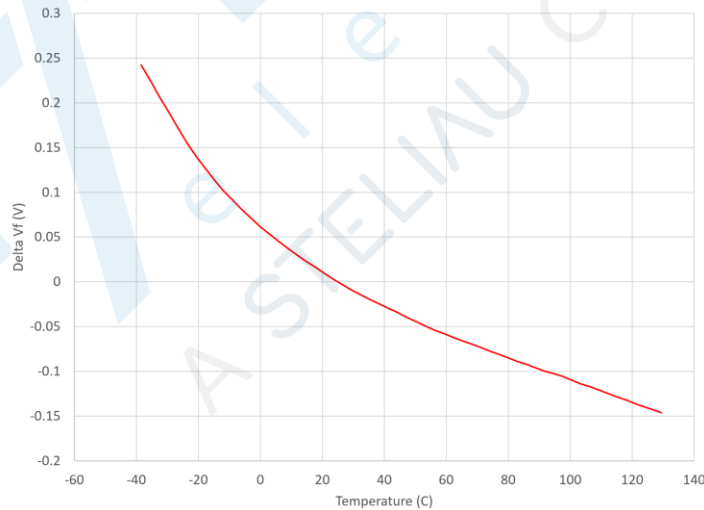

Figure 9. Red LED relative forward voltage vs junction temperature over a wide range of temperatures. The normal operating junction temperature is in the linear range but 25 °C is near the onset of the low-temperature curvature region.

Another nonlinearity due to device physics is observed at low currents. For example, the TDIM method uses a DC sense current for K-factor calibration rather than a pulse. The current level is selected to be low and not heat up the junction appreciably but needs to be high enough that the measurements are reasonably linear. Figure 10 shows data for LEDs calibrated at varying low DC sense currents (1, 5, and 10 mA). Due to temperature dependent device leakage effects, lower currents are less linear.

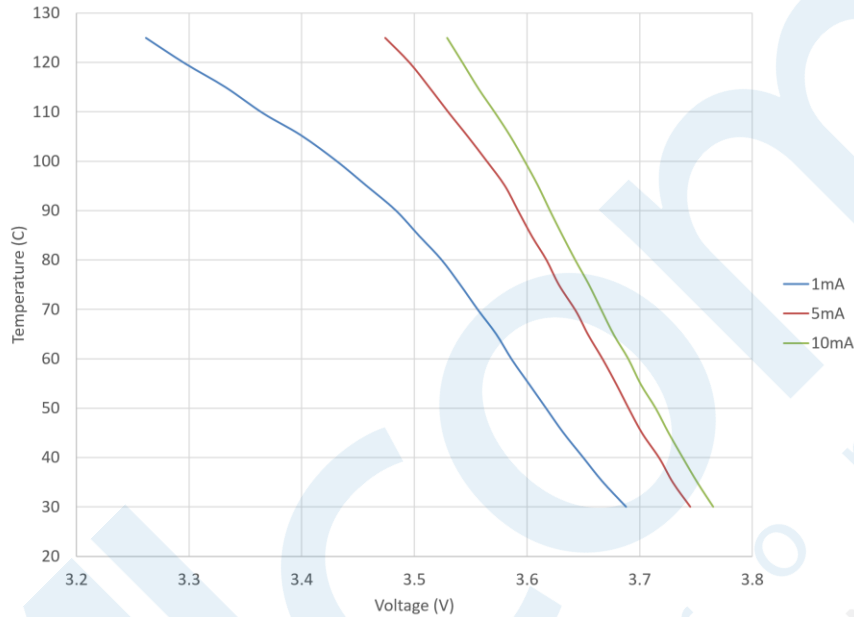

Figure 10. Example of high-temperature nonlinearity due to low sense current levels in a TDIM calibration [7]. JEESD-51 attributes this effect to temperature dependent low current device leakage.

Non-Linearities Due to the Pulse Process

To mitigate inaccurate V_f measurements due to self-heating effects, it is advisable to use fast pulses. You can monitor the LED voltage using an oscilloscope to check for voltage changes over time during the pulse period due to self-heating; a voltage drop during pulsing indicates self-heating (Figure 11). In such instances using a faster pulse is advised.

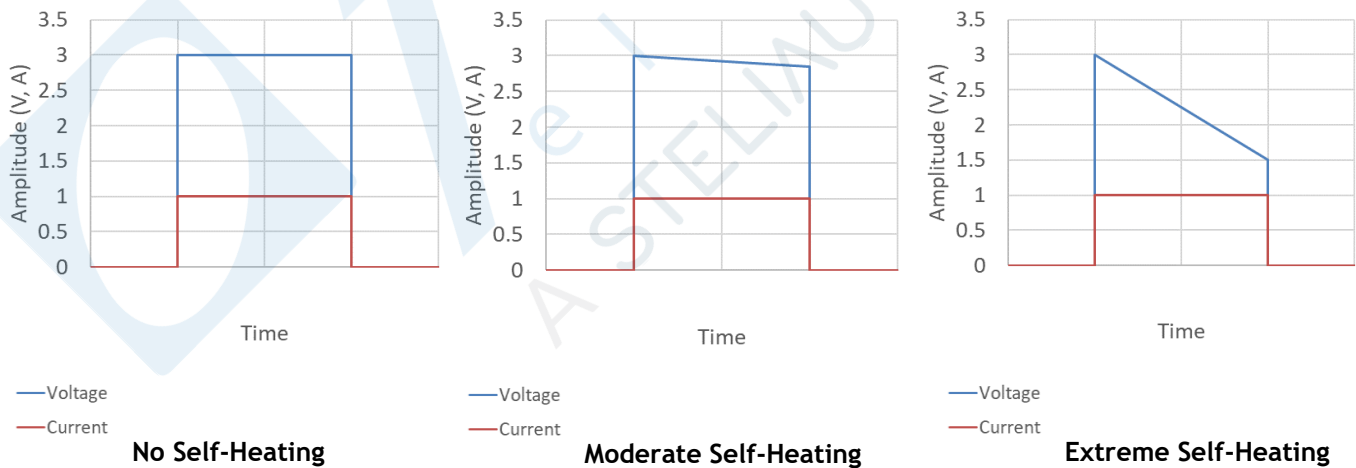

Figure 11. Representation of the effect of self-heating on the measured voltage showing drops due to moderate (center) and extreme (right) self-heating.

In the case of extreme self-heating during a pulse when the power supply measures the voltage near the end of the pulse, the voltage value tends to be more influenced by the current-induced junction heating rather than the ambient temperature. Figure 12 shows the deterioration of the data quality as self-heating starts to dominate the measurement. In this data set, the data is good up to 6 A, but self-heating effects show up at currents above 6 A.

The curves for 1, 3, and 6 A have a normal response. The oven test temperature and the junction temperature can be considered to be equivalent. The curves for 8, 10, and 12 A show increasing self-heating effects on the voltage measurement. When this happens, the oven setpoint temperature has less relationship with the junction temperature since there is also heating due to the injected current. In extreme cases, the device junction temperature (test temperature) is almost purely a function of heating due to the current. The onset of self-heating level in this plot is where the V_f -T slope starts to change significantly, in this case at 8 A where the slope changes from -2.2 mV/K to -1.4 mV/K .

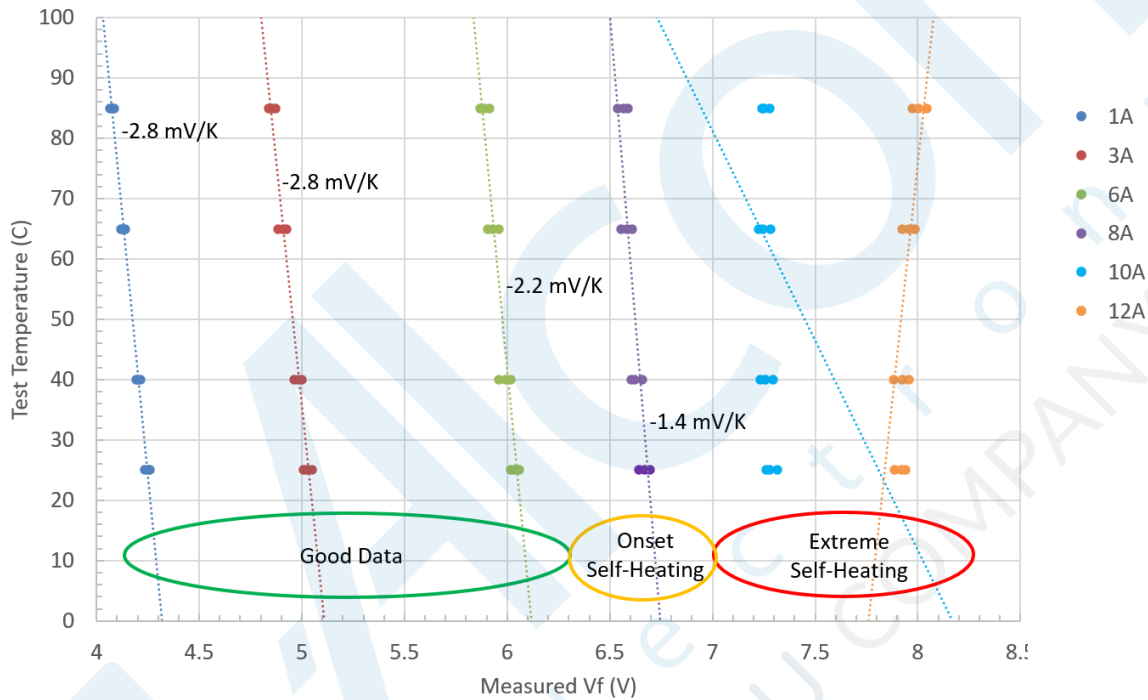

Figure 12. Example of self-heating effects at high current levels.

Another regression analysis problem can arise when the slope of the regression line is extremely steep. This is illustrated in the 10 A curve in Figure 132. Since the data is very nearly vertical the regression algorithm fails due to "perfect multicollinearity".

When using an oscilloscope or scope card to monitor voltages, electrical ringing due to circuit inductance on the pulse waveforms must be discounted (Figure 13). Electrical ringing has nothing to do with junction temperature and an appropriate sampling window should be used to measure voltage in a timeframe that corresponds to junction temperature.

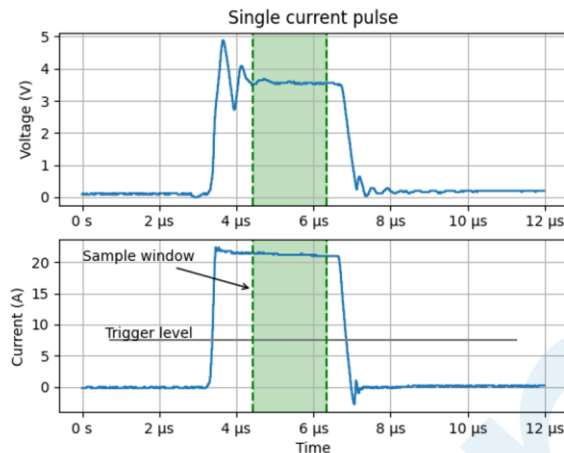

Figure 13. Example of LRC electrical ringing measured in an LED component subjected to a 20 A electrical pulse.

5.0 Thermistors

Thermistor and NTC are both used in literature. NTC stands for "Negative Temperature Coefficient". Luminus uses Murata Thermistors, specifically the NCP18XH103J03RB and the NCP15XH103J03RC. These two devices have the same Resistance Vs. Temperature response curve. The only difference is the size of the thermistor. The Murata website has product information here:

<https://www.murata.com/en-us/products/productdetail?partno=NCP18XH103J03RB>

<https://www.murata.com/en-us/products/productdetail?partno=NCP15XH103J03RC>

There is a Luminus online calculator at

<https://7w4gu55aofsagtmv.anvil.app/S2C6EXFFQQ75QYTBQ7MIUG2N> where you can move a slider to change the resistance and calculate the thermistor temperature. This calculator uses the tabulated R-center values found on the Murata website (Figure 14).

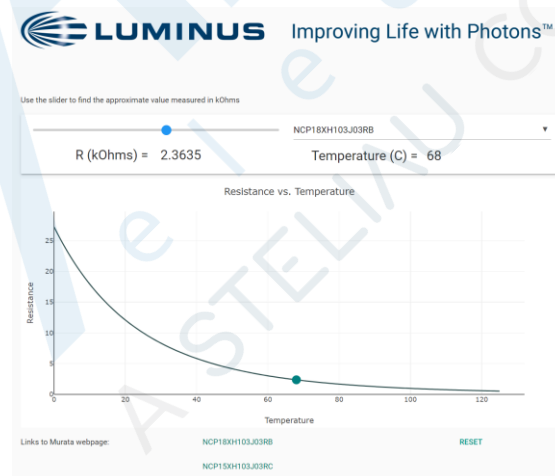

Figure 14. Luminus thermistor calculator.

For benchtop applications, a multimeter can be used to directly measure the thermistor resistance. For feedback control, the power supply usually has a thermistor connector port that sends a small sense current through the thermistor and measures the voltage. The user is advised to consult the power supply documentation since there are many variations.

6.0 Conclusion

With an understanding of how to calibrate LEDs with thermistors, engineers can ensure that the design, materials, and configuration of devices support appropriate thermal management and performance. This can be done by considering LED thermal resistance (R_{th-jc}) and the LED-to-thermistor characterization parameter ($R_{th-jref}$), using the K-factor (the measured dT/dV slope), and using the methods explained and demonstrated in this White Paper.

7.0 Resources

For additional information, we recommend the following resources:

In-Depth Information

- **Luminus Application Notes, Product Briefs, White Papers, and FAQ:**
<https://luminusdevices.zendesk.com/hc/en-us>

Questions

For assistance with your high-luminance thermal management and engineering questions, please contact:

- **Application Engineering Support:** techsupport@luminus.com

8.0 Glossary

Electronic Thermal Resistance $R_{th-elec}$ - defined on page 1.

K Factor - the measured dT/dV slope. When voltage is plotted on the x-axis of a graph and temperature on the y-axis, the K factor is the slope of the data.

PCB - Printed Circuit Board.

Real Thermal Resistance $R_{th-real}$ - defined on page 1.

TDIM - Transient Dual Interface Measurement. A thermal analysis method explained in this white paper.

Thermal Resistance, R_{th-jc} - defined on page 1.

Thermal Characterization Parameter, $R_{th-jref}$, - defined on page 1.

TIM - Thermal interface material. A material used between two surfaces to reduce thermal contact resistance due to surface texture.

9.0 References

- [1] “LED Temperature Protection by Vf Monitoring”, Texas Instruments application report SLVAEB5-May 2019, <https://www.ti.com/lit/an/slvaeb5/slvaeb5.pdf?ts=1591308499843>
- [2] “Transient Dual Interface Test Method for the Measurement of the Thermal Resistance Junction-to-Case of Semiconductor Devices with Heat Flow Through a Single Path”, JESD-51-14, JEDEC Solid State Technology Association, 2010, <https://www.jedec.org/standards-documents/docs/jesd51-14-0>.
- [3] “Simplified methods for characterizing thermal parameters of high-power automotive LEDs”, A.J. Robinson, et al., Case Studies in Thermal Engineering, Volume 35, July 2022, <https://www.sciencedirect.com/science/article/pii/S2214157X22004038?via%3Dihub>
- [4] “How to Use Thermal Data Found in Data Sheets, AND8220/D, Onsemi, 2022, <https://www.onsemi.com/pub/collateral/and8220-d.pdf>
- [5] JESD51-52 “Guidelines For Combining Cie 127:2007 / 225:2017 Total Flux Measurements With Thermal Measurements Of LEDs With Exposed Cooling Surface”, JEDEC Solid State Technology Association, April 2012, https://www.jedec.org/document_search?search_api_views_fulltext=Standard+JESD51-52
- [6] “Integrated Circuits Thermal Measurement Method - Electrical Test Method (Single Semiconductor Device)”, EIA/JEDEC Standard No. 51-1, 1995, <https://www.jedec.org/sites/default/files/docs/jesd51-1.pdf>.
- [7] “Component Thermal Characterization: Transient to Steady State” Dr. John W. Sofia, October 2011. <https://analysistech.com/wp-content/uploads/2017/02/ComponentChar11-2011.pdf>

The products, their specifications and other information appearing in this document are subject to change by Luminus Devices without notice. Luminus Devices assumes no liability for errors that may appear in this document, and no liability otherwise arising from the application or use of the product or information contained herein. None of the information provided herein should be considered to be a representation of the fitness or suitability of the product for any particular application or as any other form of warranty. Luminus Devices’ product warranties are limited to only such warranties as accompany a purchase contract or purchase order for such products. Nothing herein is to be construed as constituting an additional warranty. No information contained in this publication may be considered as a waiver by Luminus Devices of any intellectual property rights that Luminus Devices may have in such information.



Singel 3 | B-2550 Kontich | Belgium | Tel. +32 (0)3 458 30 33 | info@alcom.be | www.alcom.be
Rivium 1e straat 52 | 2909 LE Capelle aan den IJssel | The Netherlands | Tel. +31 (0)10 288 25 00 | info@alcom.nl | www.alcom.nl

Luminus Devices, Inc. T. 408 708 7000
1145 Sonora Court

www.luminus.com
Sunnyvale, CA 94086