

# Comparison

	Monopole	TELA	Pillar
Design principle	Monopole	Loop	Monopole
Gain	0~2 dBi	0~2 dBi	1~3 dBi
Gain Pattern		Omni-directional	XY plane
Polarization	Linear, Horizontal	Linear, Horizontal	Linear, Vertical
Location	Corner 	Mid of the edge 	Any 

Gain Pattern			
--------------	---	--	---

# Advantages of Pillar Antenna

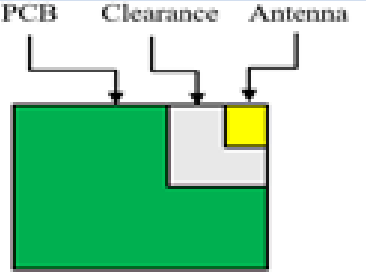
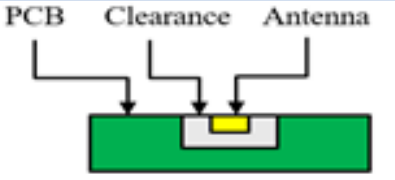
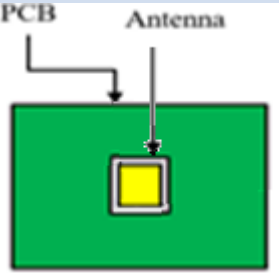
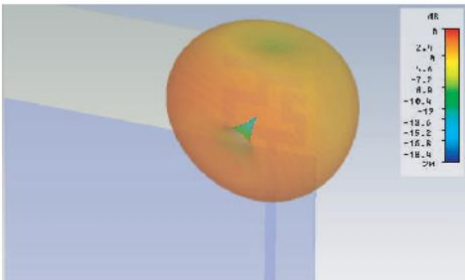
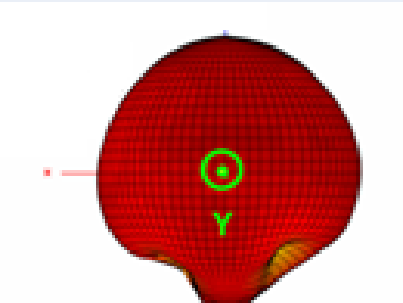
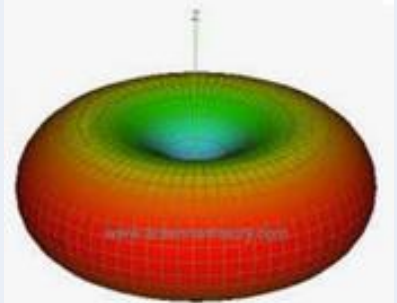
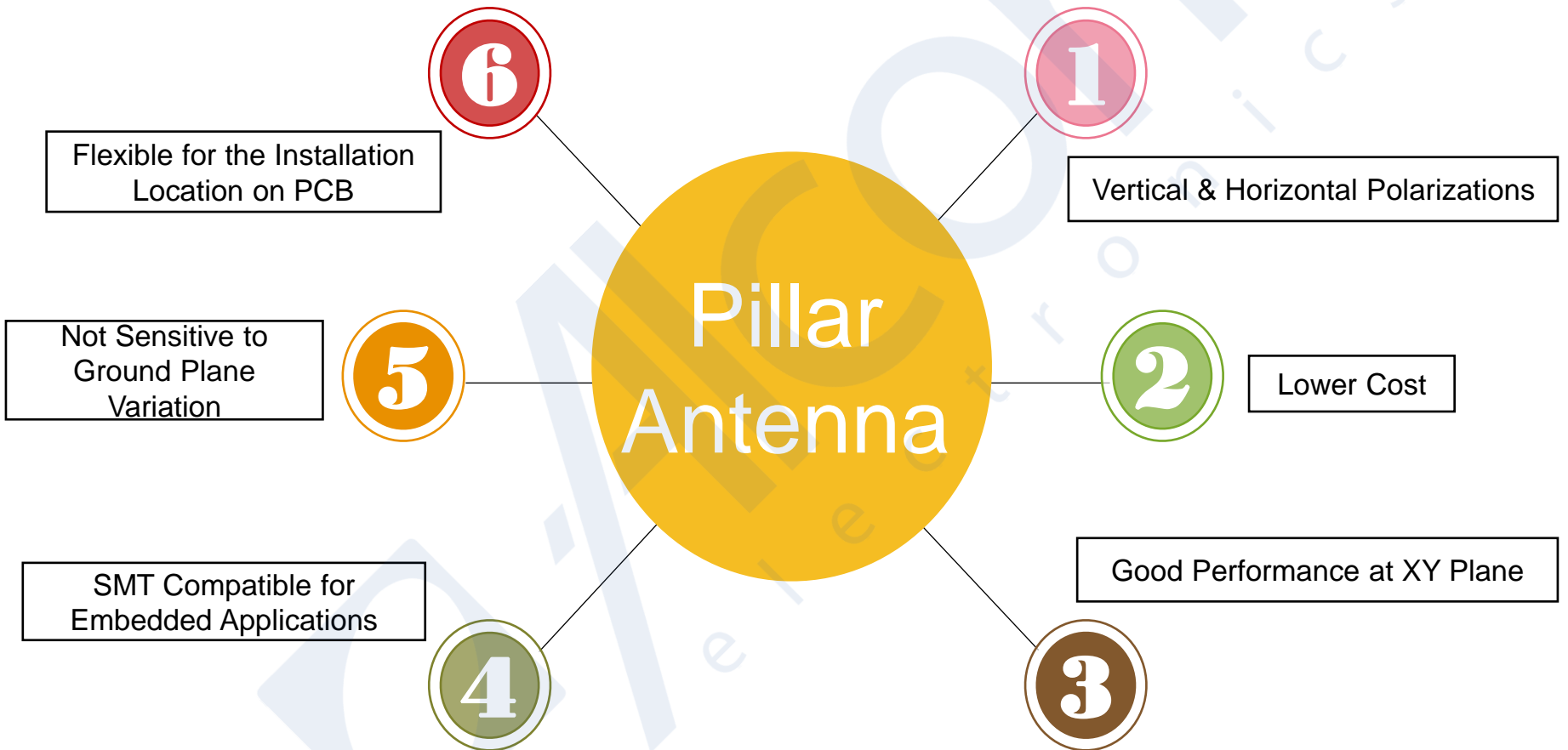

# Pillar Antenna Roadmap



# Pillar -- CW337

- Can be placed **anywhere** on the PCBA
- Requires **no ground clearance** to operate
- Suitable solution for **wearables**

