



GWU2U Datasheet

UG1005-1.0E, 06/29/2021

Copyright © 2021 Guangdong Gowin Semiconductor Corporation. All Rights Reserved.

GOWIN, Gowin, and GOWINSEMI are trademarks of Guangdong Gowin Semiconductor Corporation and are registered in China, the U.S. Patent and Trademark Office, and other countries. All other words and logos identified as trademarks or service marks are the property of their respective holders. No part of this document may be reproduced or transmitted in any form or by any denotes, electronic, mechanical, photocopying, recording or otherwise, without the prior written consent of GOWINSEMI.

Disclaimer

GOWINSEMI assumes no liability and provides no warranty (either expressed or implied) and is not responsible for any damage incurred to your hardware, software, data, or property resulting from usage of the materials or intellectual property except as outlined in the GOWINSEMI Terms and Conditions of Sale. All information in this document should be treated as preliminary. GOWINSEMI may make changes to this document at any time without prior notice. Anyone relying on this documentation should contact GOWINSEMI for the current documentation and errata.

Revision History

Date	Version	Description
06/29/2021	1.0E	Initial version published.



Contents

Contents	1
List of Figures	vi
List of Tables	vii
1 General Description	1
1.1 Overview	1
1.2 Features.....	1
1.3 Typical Applications	2
1.4 Driver Supported.....	2
2 Package	3
2.1 QN32 Pin Description	4
2.2 QN32 Package Outline	5
2.3 Package Marking	6
3 Function Description	7
3.1 Hardware Description	7
3.2 Asynchronous High-Speed Serial Interface.....	8
4 Driver Description	9
5 Device Characteristics and Parameters	10
5.1 Absolute Max. Parameters	10
5.2 Electrical Parameters	10
5.3 Timing Parameters.....	11
5.4 ESD Parameters.....	11
6 Typical Applications	12
6.1 USB to RS232 Application	12
6.2 USB to MCU UART Application	13

Terminology and Abbreviations 14
Support and Feedback..... 15



List of Figures

Figure 1-1 GWU2U Structure View.....	1
Figure 2-1 QN32 Pin-Out.....	4
Figure 2-2 QN32 Package Outline.....	5
Figure 2-3 Package Mark Meaning.....	6

List of Tables

Table 2-1 Product Package Resources	3
Table 2-2 QN32 Pin Description	4
Table 5-1 Absolute Max. Parameters	10
Table 5-2 Electrical Parameters	10
Table 5-3 Timing Parameters	11
Table 5-4 ESD Paramrters	11
Table A-1 Terminology and Abbreviations	14

1 General Description

1.1 Overview

GWU2U is an ASSP bridge chip in the Gowin Gobridge family that converts USB to/and from UART peripheral interfaces. It is a highly integrated, low-power, and single-chip solution for communicating with a UART peripheral interface over USB. The structure view is as shown in Figure 1-1.

Figure 1-1 GWU2U Structure View

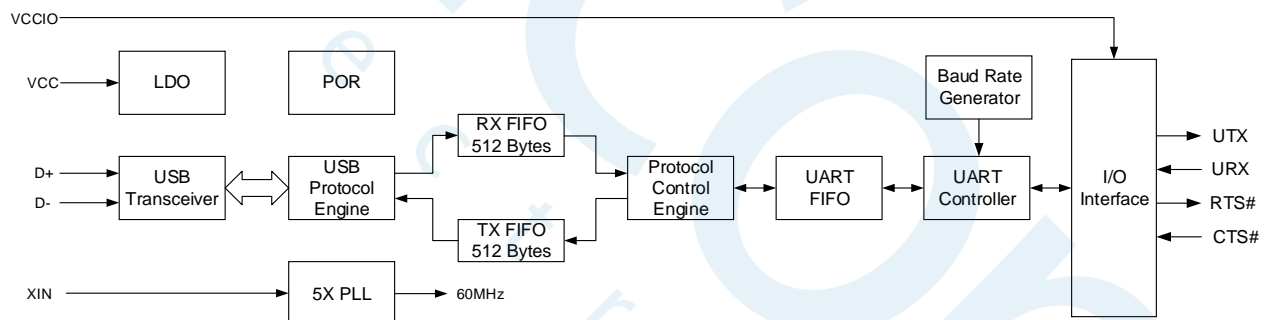

1.2 Features

- Supports full-speed USB device interface, compatible with the USB v1.1 specification.
- Built-in USB protocol processing, without device firmware programming.
- Supports USB to UART function;
- Supports full-duplex asynchronous communication with built-in independent transceiver buffers.
- Supports data baud rate: 64bps~4Mbps.
- Supports 5/6/7/8 bit width.

- Supports parity mode: none/even/odd/space/mark.
- Independent I/O power supply, supports multiple level standards.
- API provided for host device usage.

1.3 Typical Applications

- USB products field upgrading
- USB Industry control
- USB-based instruments
- USB to UART bus interface

1.4 Driver Supported

GWU2U supports the WinUSB drivers as below:

- Windows XP 64 bits
- Windows 7/Windows 10 32 bits,64 bits

2 Package

GWU2U package information is described in Table 2-1 as below.

Table 2-1 Product Package Resources

Package	Pitch (mm)	Size (mm)
QN32	0.5	5 x 5

2.1 QN32 Pin Description

Figure 2-1 QN32 Pin-Out

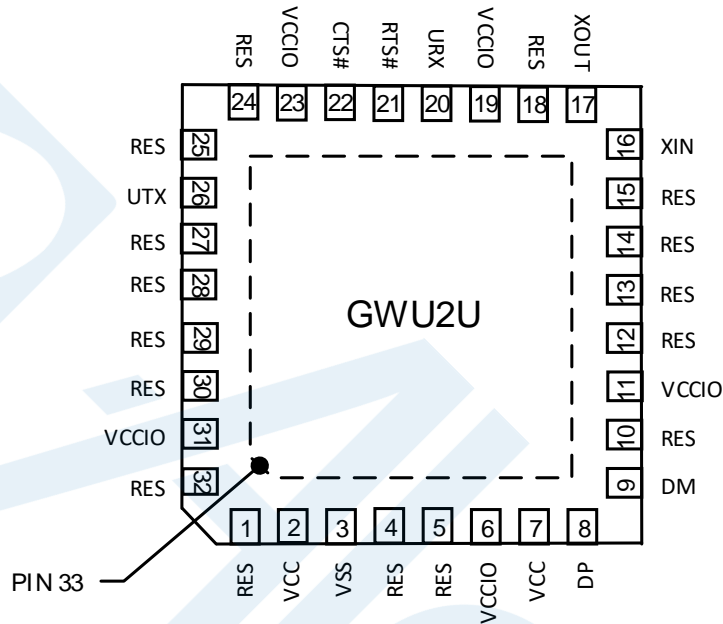

Table 2-2 QN32 Pin Description

Pin No.	Pin Name	Type	Description
2/7	VCC	Power Supply	Power Input
6/11/ 19/23/31	VCCIO	Power Supply	Input/Output Pin Voltage
3/33	VSS	Power Ground	Common Ground
16	XIN	Clock	Input of crystal oscillation, external crystal and oscillation capacitor
17	XOUT	Clock	Reverse output of crystal oscillation, with external crystal and oscillation capacitor
8	DP	Two-Way	USB Data signal D+; 1.5K pull-up resistor needs to be connected
9	DM	Two-Way	USB data signal D-
21	RTS#	Output	Request to transmit
22	CTS#	Input	Clear transmit
26	UTX	Output	Serial data output

Pin No.	Pin Name	Type	Description
20	URX	Input	Serial data input
1/4/5/10/12/13/ 14/15/18/24/25/ 27/28/29/30/32	RES	-	Reserved port. Need to be left floating

2.2 QN32 Package Outline

Figure 2-2 QN32 Package Outline

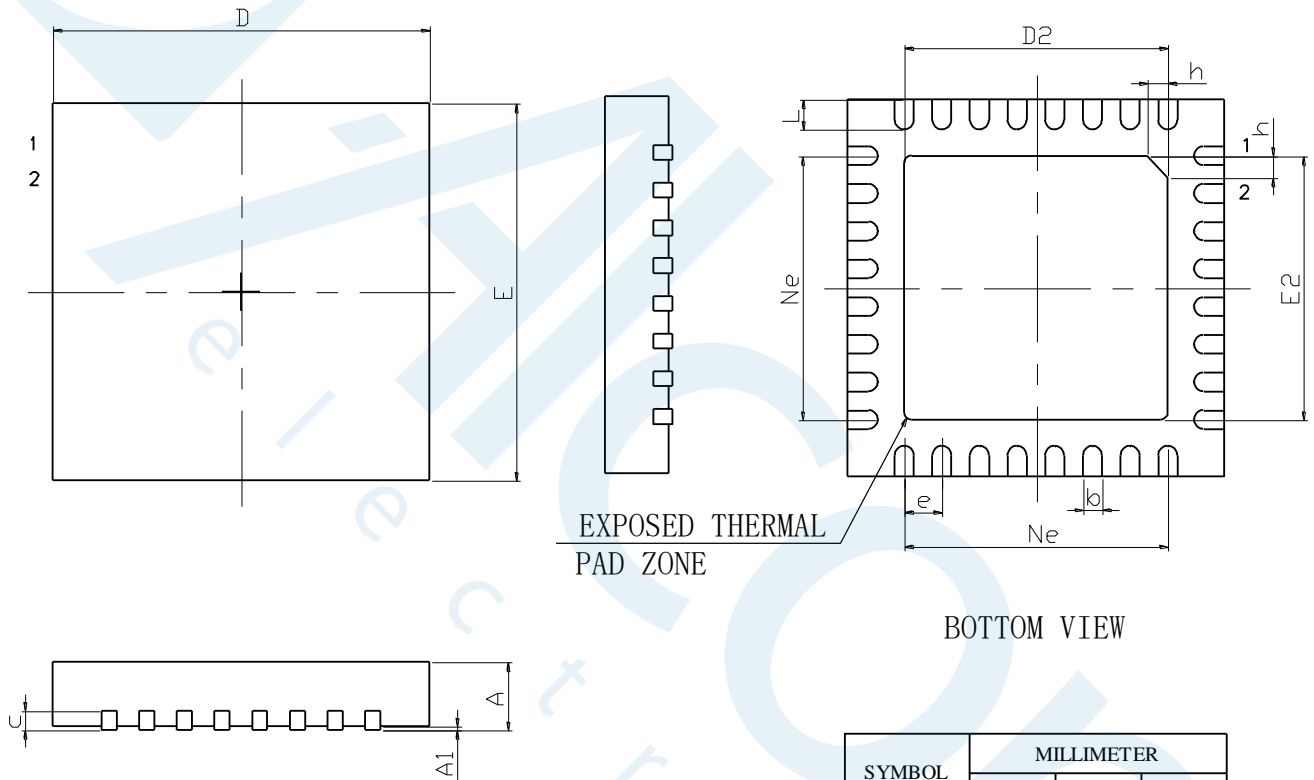

BOTTOM VIEW

SYMBOL	MILLIMETER		
	MIN	NOM	MAX
A	0.70	0.75	0.80
A1	0	0.02	0.05
b	0.18	0.25	0.30
c	0.18	0.20	0.25
D	4.90	5.00	5.10
D2	3.40	3.50	3.60
e	0.50BSC		
Ne	3.50BSC		
E	4.90	5.00	5.10
E2	3.40	3.50	3.60
L	0.35	0.40	0.45
h	0.30	0.35	0.40

2.3 Package Marking

Figure 2-3 Package Mark Meaning

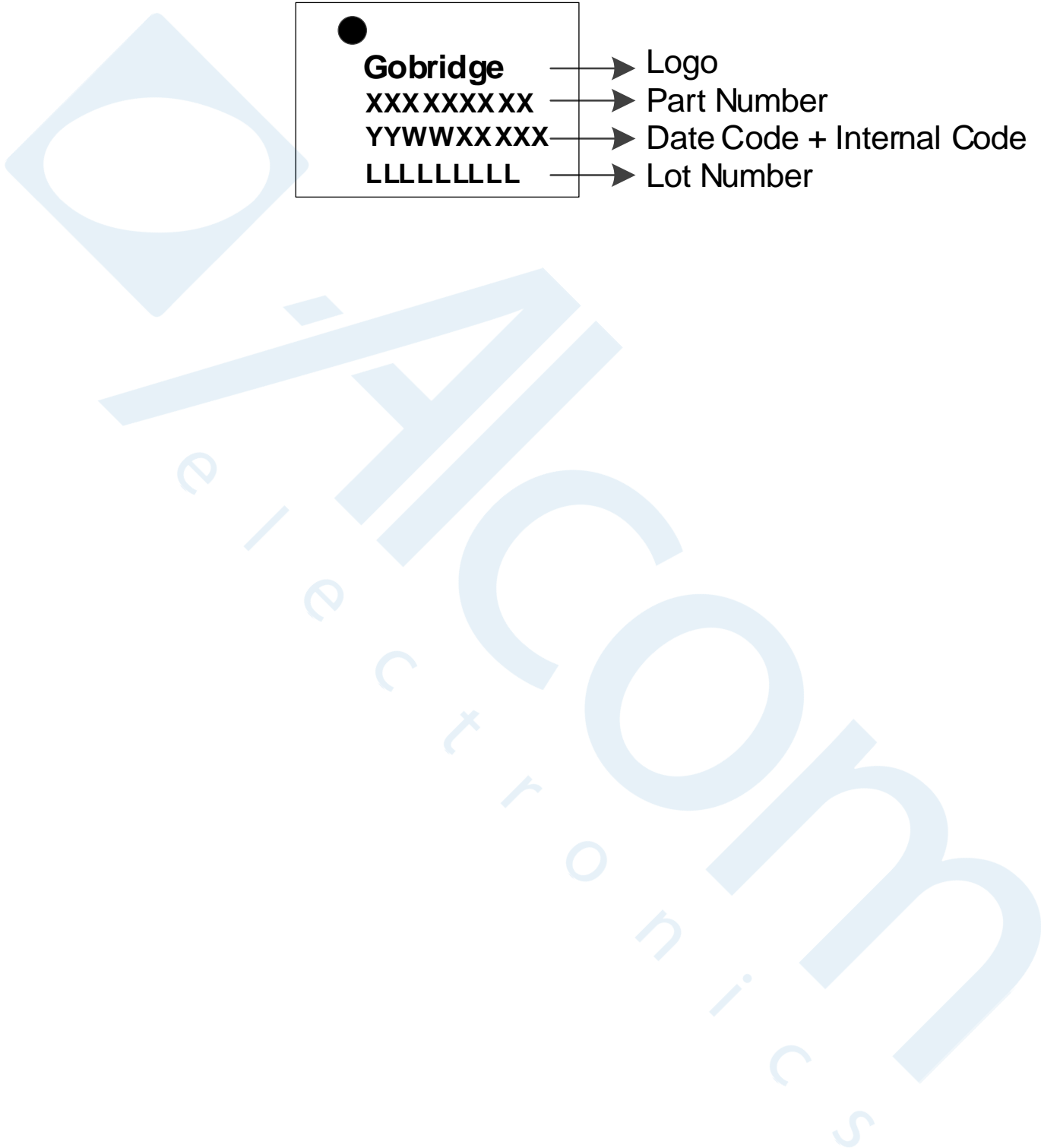

3 Function Description

3.1 Hardware Description

- Both VCC and VCCIO need to be provided for the GWU2U chip to work normally. It is suggested to connect a power decoupling capacitor with a capacity of 0.01uF ~ 0.1uF to the power pin of each chip. The synchronous serial interface voltage can be adjusted dynamically through VCCIO, with the range of 2.5V~3.4V.
- A 12MHz external clock signal to the XIN pin is required for normal operation of the GWU2U chip. Normally, the clock signal is generated by the GWU2U built-in inverter via crystal frequency stabilization oscillation. The peripheral circuit only requires a 12MHz crystal connected between the XIN and XOUT pins and oscillation capacitors connected to ground for the XIN and XOUT pins, respectively.
- GWU2U chip has built-in power on reset circuit, and no external reset is required.
- The USB port of GWU2U chip has no built-in pull-up resistor, and additional 1.5K pull-up resistor needs to be provided at the DP end. It is recommended to connect the insurance resistor or inductor or ESD protection device in series for safety, and the AC-DC equivalent series resistance should be within 5Ω.

3.2 Asynchronous High-Speed Serial Interface

The pins of the GWU2U chip in asynchronous serial mode include: data transmission pins and hardware flow control pins, where the data transmission pins are UTX and URX, and the hardware flow control pins are RTS# and CTS#.

The chip contains an independent data buffer internally and supports full-duplex asynchronous serial communication. It supports 5~8 data bits; supports 1/2 stop bits; supports parity mode including none, even, odd, space, mark; supports baud rate ranging from 64 to 4000000. The baud rate error of the serial port transmit signal is less than 0.3%, and the allowable baud rate error of the serial port receive signal is about 2%.

The GWU2U driver enables the emulation of standard serial ports under the Windows operating system on the computer side, thus most of the original serial applications are fully compatible and usually do not require any modification. The GWU2U can be used to upgrade the original serial peripherals or to add additional serial ports to the computer via the USB bus. Further interfaces such as RS232, RS485, RS422, etc. can be provided by adding level conversion devices.

4 Driver Description

For more information about the driver, please refer to the following manuals:

- [UG1006](#), GWU2U Driver (libusb+WinUSB based) User Guide
- [UG1007](#), GWU2U Driver (Windows VCP) User Guide

5 Device Characteristics and Parameters

5.1 Absolute Max. Parameters

Table 5-1 Absolute Max. Parameters

Parameter	Description of Parameter	Min.	Max.	Unit
TA	Ambient temperature during work	-40	85	°C
TS	Ambient temperature during storage	-65	150	°C
VCC	Power voltage	-0.5	3.75	V
VCCIO	Input/Output Pin Voltage	-0.5	3.75	V

5.2 Electrical Parameters

Table 5-2 Electrical Parameters

Parameter	Description of Parameter	Min.	Typ.	Max.	Unit
VCC	Power voltage	3	3.3	3.6	V
VCCIO	Input/Output Pin Voltage	2.5	-	3.4	V
Icc1	Total power supply current during operation	-	35	-	mA
VIL	Low-level input voltage	-0.3	-	0.35*VCCO	V
VIH	High-level input voltage	0.65*VCCO	-	3.6	V
VOL	Low-level output voltage (Drive current = 8mA)	-	-	0.4	V
VOH	High-level output voltage	VCCO-0.4	-	-	V

Parameter	Description of Parameter	Min.	Typ.	Max.	Unit
	(Drive current = 6mA)				
UVOL	USB Low-level output voltage	-	-	0.4	V
UVOH	USB High-level output voltage	2.8	-	-	V
UVse	Single-ended receive threshold	0.8	-	2.0	V

5.3 Timing Parameters

Table 5-3 Timing Parameters

Parameter	Description of Parameter	Min.	Typ.	Max.	Unit
FCLK	The Input clock signal frequency of XIN pin	-	12	-	Mhz
TPR	Reset time of power on	-	5	-	mS

5.4 ESD Parameters

Table 5-4 ESD Paramrters

Parameter	Description of Parameter	Min.	Typ.	Max.	Unit
HBM	Human Body Model	1000	-	-	V
CDM	Charged Device Model	500	-	-	V

6 Typical Applications

6.1 USB to RS232 Application

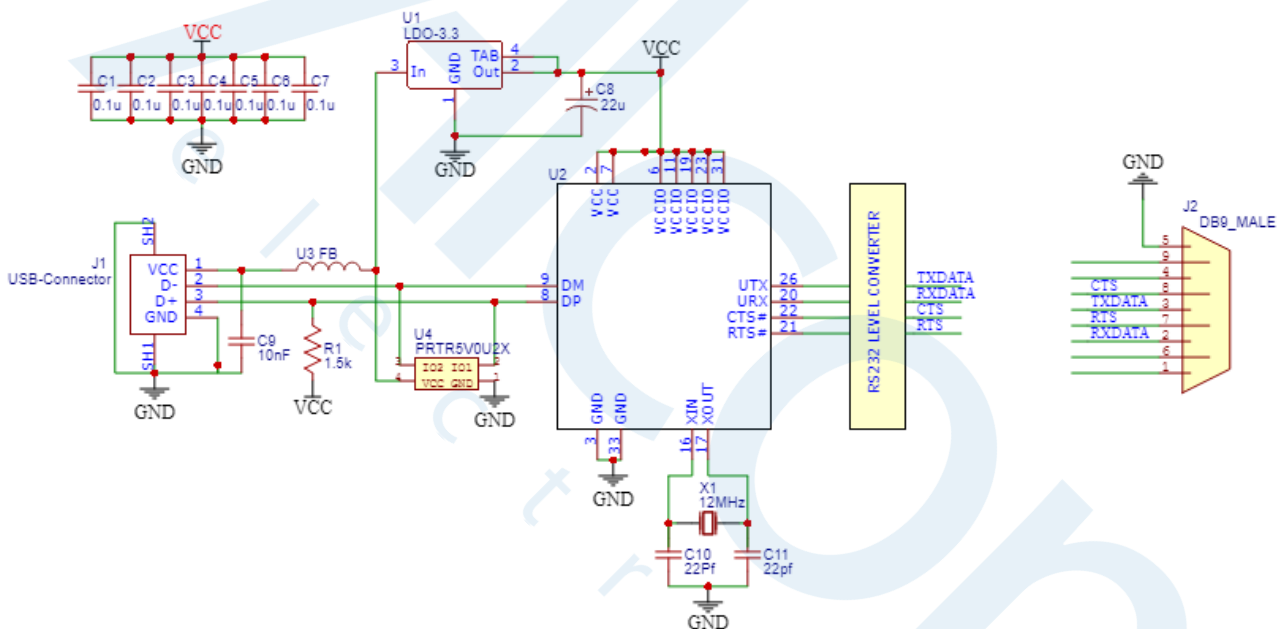

6.2 USB to MCU UART Application

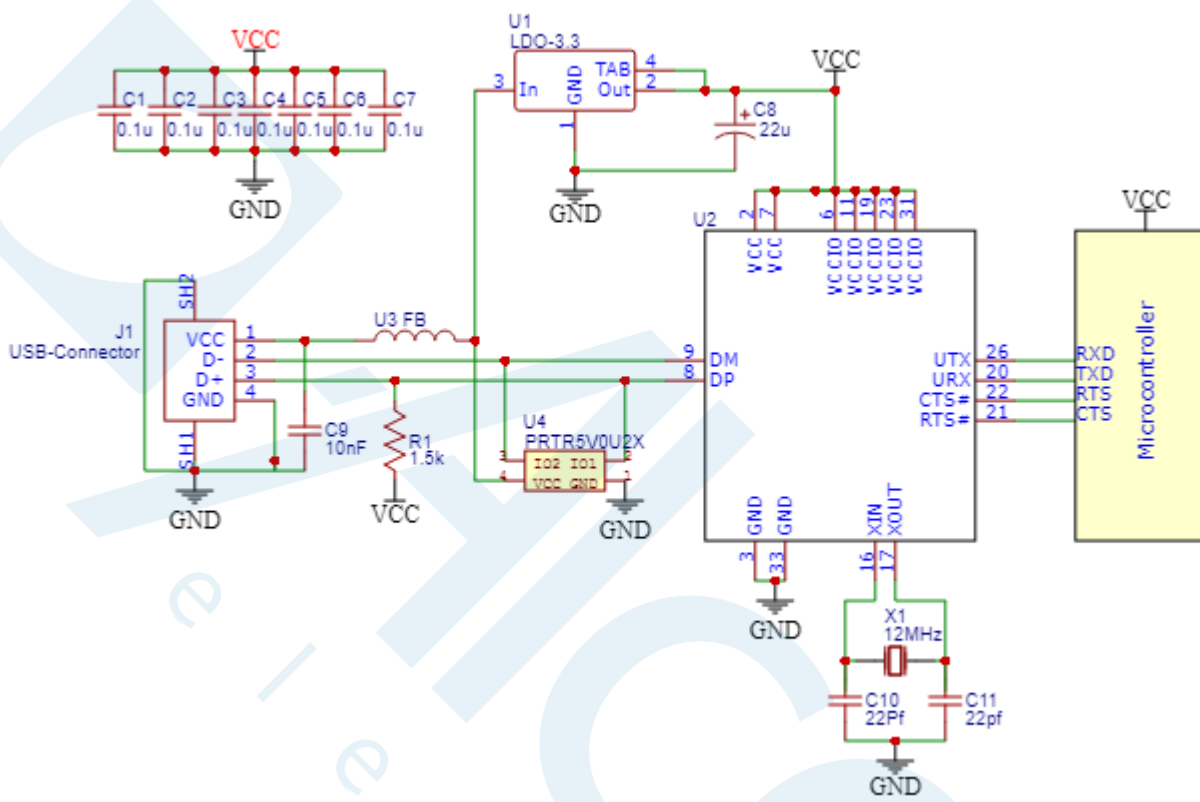

Terminology and Abbreviations

The terminology and abbreviations used in this manual are as shown in Table A-1.

Table A-2 Terminology and Abbreviations

Terminology and Abbreviations	Meaning
ASSP	Application Specific Standard Product
GPIO	Gowin Programmable Input/Output
QN	Quad Flat No-lead Package
ESD	Electrostatic Discharge
MCU	Microcontroller Unit
UART	Universal Asynchronous Receiver/Transmitter

Support and Feedback

Gowin Semiconductor provides customers with comprehensive technical support. If you have any questions, comments, or suggestions, please feel free to contact us directly by the following ways.

Website: www.gowinsemi.com

E-mail: support@gowinsemi.com



electronics



Singel 3 | B-2550 Kontich | Belgium | Tel. +32 (0)3 458 30 33 | info@alcom.be | www.alcom.be
Rivium 1e straat 52 | 2909 LE Capelle aan den IJssel | The Netherlands | Tel. +31 (0)10 288 25 00 | info@alcom.nl | www.alcom.nl

