

HIGH POWER LOW CAPACITANCE TVS HYBRID ARRAY



DESCRIPTION

The PTA03-3.3ULC is a high power, low capacitance TVS hybrid array; designed to protect high speed data line applications from the damaging effects of ESD, EFT and secondary transient threats. This device is available in an SOIC-8 package configuration and has a peak pulse power rating of 2000 Watts (8/20 μ s waveshape). The PTA03-3.3ULC is designed to provide low capacitance, even at higher temperatures ($T_j = 75^\circ\text{C}$), when connected in differential mode. This device meets the IEC 61000-4-2, IEC 61000-4-4 and IEC 61000-4-5 requirements.

FEATURES

- Compatible with IEC 61000-4-2 (ESD): Air $\pm 15\text{kV}$, Contact $\pm 8\text{kV}$
- Compatible with IEC 61000-4-4 (EFT): 40A - 5/50ns
- Compatible with IEC 61000-4-5 (Surge): 70A, 8/20 μ s
- 100A (2/10 μ s) per Bellcore GR1089 (Intra-Building)
- ESD Protection > 30kV, Contact per IEC 61000-4-2
- 2000 Watts Peak Pulse Power per Line ($t_p = 8/20\mu\text{s}$)
- Low Capacitance: Max 2.4pF (I/O to I/O)
- Telecom/Diode Bridge Configuration
- RoHS Compliant
- REACH Compliant

APPLICATIONS

- Ethernet 10/100/1000 Base T
- xDSL Interfaces
- Set Top Box Interfaces
- T1/E1 Line Cards
- ISDN U-Interfaces & ISDN S/T Interfaces

MECHANICAL CHARACTERISTICS

- Molded JEDEC SO-8 Package
- Approximate Weight: 70 milligrams
- Lead-Free Pure-Tin Plating (Annealed)
- Solder Reflow Temperature:
Pure-Tin - Sn, 100: 260-270 $^\circ\text{C}$
- 12mm Tape and Reel Per EIA Standard 481
- Flammability Rating UL 94V-0

PIN CONFIGURATION

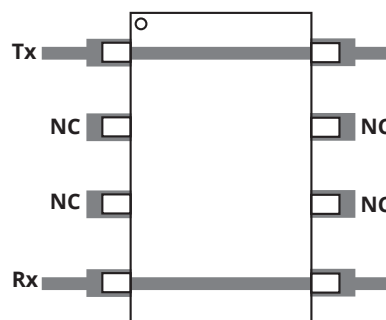
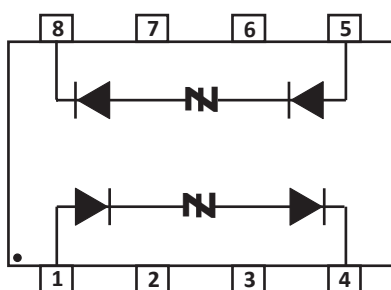

PCB layout configuration: Rail-to-Rail in differential mode.

TYPICAL DEVICE CHARACTERISTICS
MAXIMUM RATINGS @ 25°C Unless Otherwise Specified

PARAMETER	SYMBOL	VALUE	UNITS
Operating Temperature	T_L	-55 to 150	°C
Storage Temperature	T_{STG}	-55 to 150	°C
Peak Pulse Power ($t_p = 8/20\mu s$) - See Figure 1	P_{PP}	2000	Watts

ELECTRICAL CHARACTERISTICS PER LINE @ 25°C Unless Otherwise Specified

PART NUMBER	DEVICE MARKING	RATED STAND-OFF VOLTAGE V_{WM} VOLTS	MINIMUM SNAPBACK VOLTAGE @50mA $V_{(BR)}$ VOLTS	MAXIMUM CLAMPING VOLTAGE (Fig. 2) (Note 1) @ $I_p = 70A$ V_C VOLTS	MAXIMUM CLAMPING VOLTAGE (Fig. 2) (Note 1) @ 8/20 μs $V_C @ I_{PP}$	MAXIMUM LEAKAGE CURRENT (Note 1) @ V_{WM} I_D μA	MAXIMUM CAPACITANCE (Note 2) @0V, 1MHz C pF	MAXIMUM CAPACITANCE (Note 3) @0V, 1MHz C pF
PTA03-3.3ULC	PTA33	3.3	2.2	29.0	8.0V @ 10A	0.1	1.2	2.4

NOTES

- For an 8/20 μs waveform, apply positive pulse between pin 1 to pin 4 and pin 5 to pin 8, individually.
- Measured between IO pins (pin 1 to pin 4 and pin 5 to pin 8).
- Measured between IO pins 1 and 4, connecting via PCB trace; pin 1 to 8 and pin 4 to 5 (see page 1).

FIGURE 1
PEAK PULSE POWER VS PULSE TIME

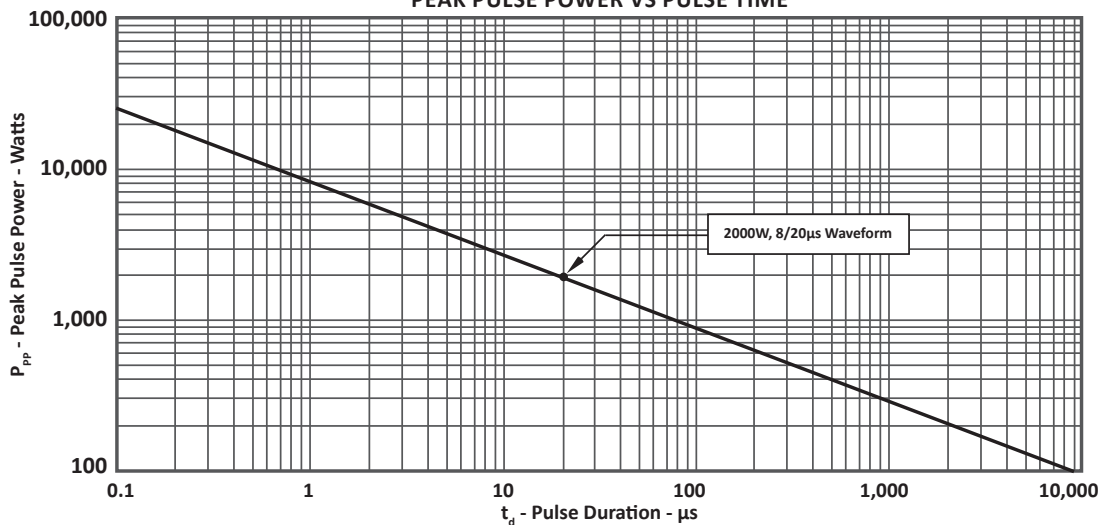

TYPICAL DEVICE CHARACTERISTICS

FIGURE 2
PULSE WAVE FORM

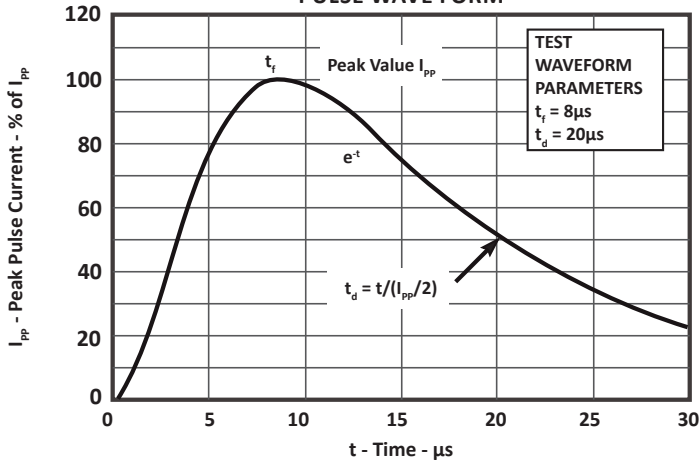

FIGURE 3
POWER DERATING CURVE 8X20 μs

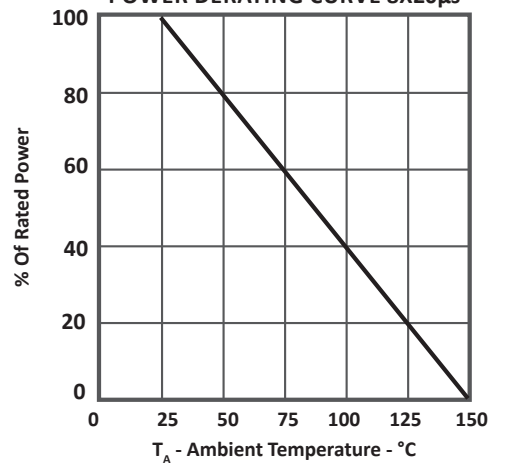
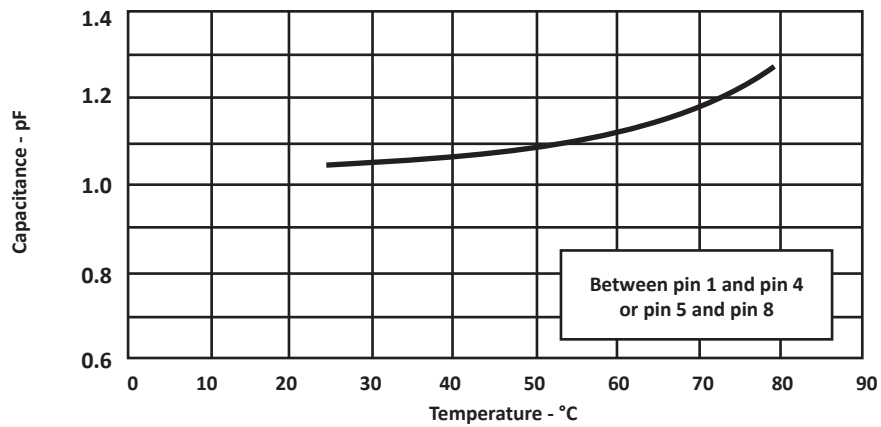

FIGURE 4
TYPICAL CAPACITANCE VS TEMPERATURE
(0V BIAS, 1MHZ)



TYPICAL DEVICE CHARACTERISTICS

FIGURE 5
TYPICAL CAPACITANCE VS BIAS
(@T_J = 70°C)

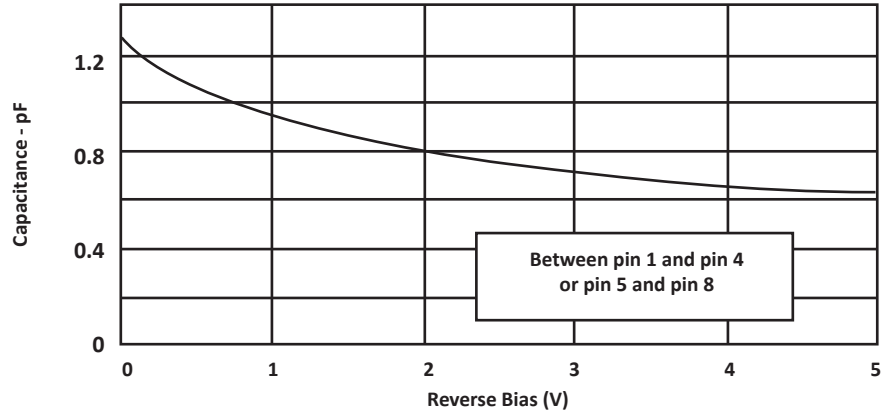
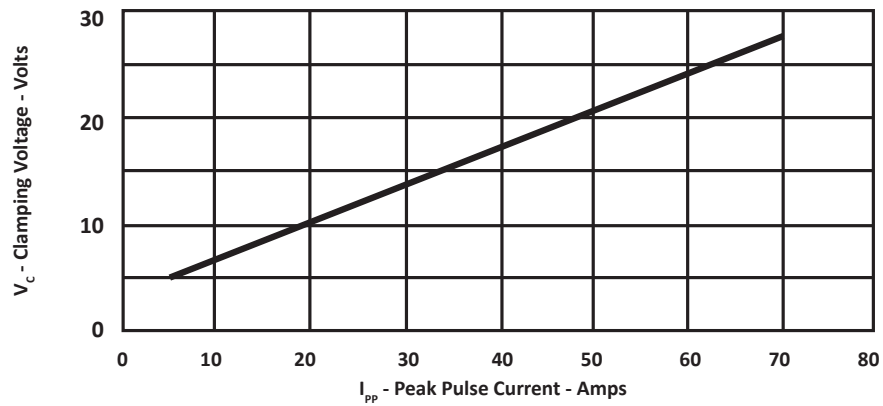

FIGURE 6
CLAMPING VOLTAGE VS PEAK PULSE CURRENT
(8/20μs)



PACKAGE INFORMATION

OUTLINE DIMENSIONS

DIM	MILLIMETERS		INCHES	
	MIN	MAX	MIN	MAX
A	4.80	5.00	0.189	0.196
B	3.80	4.00	0.150	0.157
C	1.35	1.75	0.054	0.068
D	0.35	0.49	0.014	0.019
F	0.40	1.25	0.016	0.049
G	1.27 BSC		0.05 BSC	
J	0.18	0.25	0.007	0.009
K	0.10	0.25	0.004	0.008
P	5.80	6.20	0.229	0.244
R	0.25	0.50	0.010	0.019

NOTES

- T = Seating plane and datum surface.
- Dimensions "A" and "B" are datum.
- Dimensions "A" and "B" do not include mold protrusion.
- Maximum mold protrusion is 0.015" (0.380mm) per side.
- Dimensioning and tolerances per ANSI Y14.5M, 1982.
- Dimensions are exclusive of mold flash and metal burrs.

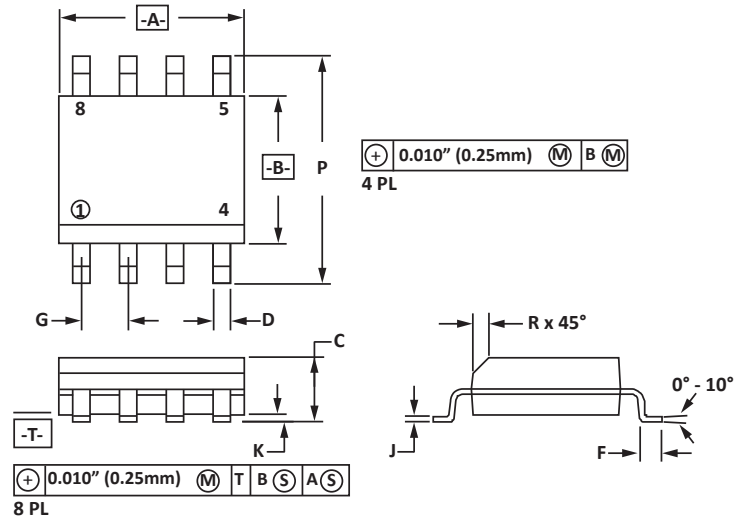

PAD LAYOUT DIMENSIONS

DIM	MILLIMETERS		INCHES	
	MIN	MAX	MIN	MAX
A	1.14	1.40	0.045	0.055
B	0.64	0.89	0.025	0.035
C	6.22	-	0.245	-
D	3.94	4.17	0.155	0.165
E	1.02	1.27	0.040	0.050

NOTES

- Controlling dimension: inches.

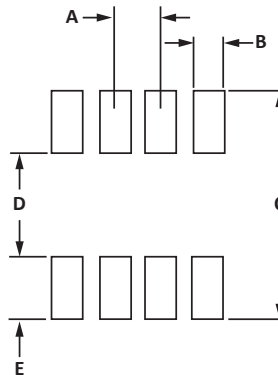

TAPE AND REEL

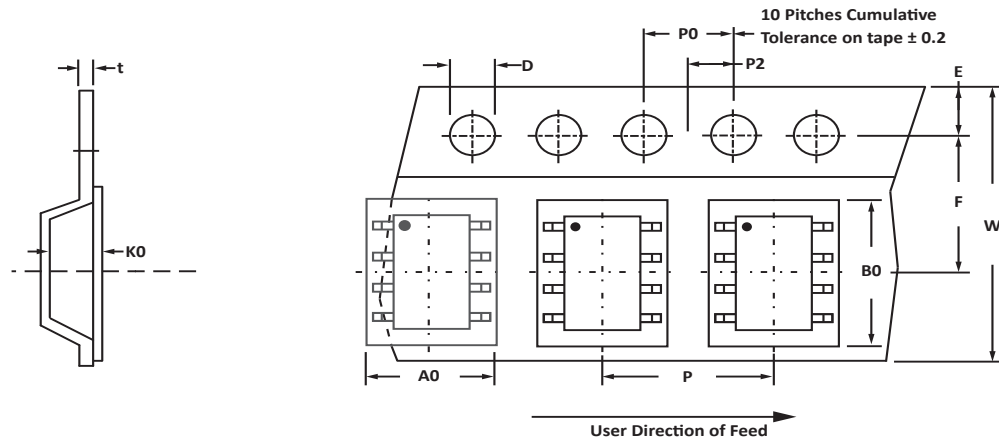

SPECIFICATIONS

REEL DIA.	TAPE WIDTH	A0	B0	K0	D	E	F	W	P0	P2	P	t _{max}
178mm (7")	12mm	6.50 ± 0.10	5.40 ± 0.10	2.00 ± 0.10	1.50 ± 0.10	1.75 ± 0.10	5.50 ± 0.05	12.00 ± 0.30	4.00 ± 0.12	2.00 ± 0.10	8.00 ± 0.10	0.25

NOTES

- Dimensions are in millimeters.
- Surface mount product is taped and reeled in accordance with EIA-481.
- Marking on Part - marking code (see page 2), date code, logo and pin one defined by dot on top of package.

ORDERING INFORMATION

BASE PART NUMBER	LEADFREE SUFFIX	TAPE SUFFIX	QTY/REEL	REEL SIZE
PTA03-3.3ULC	n/a	-T7	1,000	7"

This device is only available in a Lead-Free configuration.

COMPANY INFORMATION

COMPANY PROFILE

In business more than 30 years, ProTek Devices™ is a privately held semiconductor company. The company offers a product line of overvoltage protection that include Transient Voltage Suppressor (TVS) Arrays, Steering Diode Array Hybrids, High-power Components and Modules, as well as Steering Diodes, EMI Filter/TVS Arrays and Thyristor Surge Suppressors. These components deliver circuit protection in electronic systems from numerous overvoltage events. They include lightning; electrostatic discharge (ESD); nuclear electromagnetic pulses (NEMP); inductive switching; and electromagnetic interference (EMI) / radio frequency interference (RFI). ProTek Devices is an ISO 9001 certified company.



Singel 3 | B-2550 Kontich | Belgium | Tel. +32 (0)3 458 30 33
info@alcom.be | www.alcom.be

Rivium 1e straat 52 | 2909 LE Capelle aan den IJssel | The Netherlands
Tel. +31 (0)10 288 25 00 | info@alcom.nl | www.alcom.nl

COPYRIGHT © ProTek Devices 2023 - This literature is subject to all applicable copyright laws and is not for resale in any manner.

SPECIFICATIONS: ProTek reserves the right to change the electrical and or mechanical characteristics described herein without notice.

DESIGN CHANGES: ProTek reserves the right to discontinue product lines without notice and that the final judgement concerning selection and specifications is the buyer's and that in furnishing engineering and technical assistance. ProTek assumes no responsibility with respect to the selection or specifications of such products. ProTek makes no warranty, representation or guarantee regarding the suitability of its products for any particular purpose, nor does ProTek assume any liability arising out of the application or use of any product or circuit and specifically disclaims any and all liability without limitation special, consequential or incidental damages.