

FEATURES

- ▶ Fully Encapsulated Plastic Case for Chassis and DIN-Rail Mounting Version
- ▶ 80-160VDC Wide Input Voltage Range
- ▶ Fully Regulated Output Voltage
- ▶ High Efficiency up to 84%
- ▶ I/O Isolation 3000VAC with Reinforced Insulation
- ▶ Operating Ambient Temp. Range -40°C to +92.5°C
- ▶ No Min. Load Requirement
- ▶ Very Low No Load Power Consumption
- ▶ Under-voltage, Overload and Short Circuit Protection
- ▶ Remote On/Off Control
- ▶ EMI Emission EN 55032 Class A & FCC Level A Approved
- ▶ EMC Immunity EN 61000-4-2,3,4,5,6,8 Approved
- ▶ UL/cUL/IEC/EN 62368-1 Safety Approval & CE Marking

**NEW****PRODUCT OVERVIEW**

The MINMAX MJA06C series is the latest generation of 6Watt isolated DC-DC power module with wide input range of 80-160VDC with 9 models for 5/5.1/12/15/24/48/±12/±15/±24VDC tightly output voltage in a chassis and DIN-Rail mounting type with terminal strip connections which specifically design for electricity and renewable energy field applications. Key performance featuring high I/O isolation 3000VAC with reinforced insulation, high efficiency for wide operating ambient temp. range -40°C to +92.5°C, no min. load requirement, very low no-load power consumption, remote on/off, build-in EMC filter for EMI emission EN 55032 Class A and EMC immunity EN 61000-4-2,3,4,5,6,8 approved, build-in fault condition protection include under-voltage, overload and short circuit protection.

The MJA06C series has been intensely qualified to safety approval UL/cUL/IEC/EN 62368-1 with CB report and CE marking which offer a solution for the applications where high voltage input range, high efficiency for wide operating ambient temp. range, isolated power with high I/O isolation & insulation level, fully encapsulated package and eliminate the power board are required.

Model Selection Guide

Model Number	Input Voltage (Range) VDC	Output Voltage VDC	Output Current Max. mA	Input Current		Max. capacitive Load μF	Efficiency (typ.) @Max. Load %
				@Max. Load mA(typ.)	@No Load mA(typ.)		
MJA06-110S05C	110 (80 ~ 160)	5	1200	69	8	680	79
MJA06-110S051C		5.1	1200	70		680	79
MJA06-110S12C		12	500	66		330	83
MJA06-110S15C		15	400	66		330	83
MJA06-110S24C		24	250	65		150	84
MJA06-110S48C		48	125	67		68	82
MJA06-110D12C		±12	±250	65		150#	84
MJA06-110D15C		±15	±200	65		150#	84
MJA06-110D24C		±24	±125	66		68#	83

For each output

Input Specifications

Parameter	Conditions / Model	Min.	Typ.	Max.	Unit
Input Surge Voltage (1 sec. max.)		-0.7	---	170	VDC
Start-Up Threshold Voltage		---	---	80	
Under Voltage Shutdown		---	74	---	
Start Up Time (Power On)	Nominal Vin and Constant Resistive Load	---	30	60	ms
Input Filter	All Models	Internal Pi Type			

Remote On/Off Control

Parameter	Conditions	Min.	Typ.	Max.	Unit
Converter On	3.5V ~ 12V or Open Circuit				
Converter Off	0~1.2V or Short Circuit (Pin 1 and Pin 2)				
Control Input Current (on)	Vctrl = 5V	---	---	500	μA
Control Input Current (off)	Vctrl = 0V	---	---	-500	μA
Control Common	Referenced to Negative Input				
Standby Input Current	Nominal Vin	---	2.5	---	mA

Output Specifications

Parameter	Conditions / Model	Min.	Typ.	Max.	Unit	
Output Voltage Setting Accuracy		---	---	±2.0	%Vnom.	
Output Voltage Balance	Dual Output, Balanced Loads	---	---	±2.0	%	
Line Regulation	Vin=Min. to Max. @Full Load	---	---	±0.5	%	
Load Regulation	Io=0% to 100%	---	---	±0.5	%	
Load Cross Regulation (Dual Output Models)	Asymmetrical Load 25/100% Full Load	---	---	±5.0	%	
Minimum Load	No minimum Load Requirement					
Ripple & Noise	0-20 MHz Bandwidth	24V & ±24V & 48V Output Models	---	180	---	mV _{p-p}
		Other Output Models	---	75	---	mV _{p-p}
Transient Recovery Time	25% Load Step Change	---	---	500	μsec	
Transient Response Deviation		---	±3	±5	%	
Temperature Coefficient		---	±0.01	±0.02	%/°C	
Over Load Protection	Hiccup	---	150	---	%	
Short Circuit Protection	Continuous, Automatic Recovery (Hiccup Mode 0.2Hz typ.)					

General Specifications

Parameter	Conditions	Min.	Typ.	Max.	Unit
I/O Isolation Voltage	60 Seconds Reinforced insulation, rated for 1000Vrms working voltage	3000	---	---	VACrms
I/O Isolation Resistance	500 VDC	1000	---	---	MΩ
I/O Isolation Capacitance	100kHz, 1V	---	2200	---	pF
Switching Frequency		---	250	---	kHz
MTBF (calculated)	MIL-HDBK-217F@25°C, Ground Benign	4,162,759	---	---	Hours
Safety Approvals	UL/cUL 62368-1 recognition(UL certificate), IEC/EN 62368-1 & 60950-1(CB-report)				

EMC Specifications

Parameter	Standards & Level			Performance
EMI	Conduction	EN 55032, FCC part 15	Without external components	Class A
	Radiation			
EMS	EN55035			A
	ESD	Direct discharge	Indirect discharge HCP & VCP	
		EN61000-4-2 Air ± 8kV		Contact ± 6kV
	Radiated immunity	EN61000-4-3 10V/m		A
	Fast transient	EN61000-4-4 ±2kV		A
	Surge	EN61000-4-5 ±2kV		A
	Conducted immunity	EN61000-4-6 10Vrms		A
PFMF	EN61000-4-8 100A/m		A	

Environmental Specifications

Parameter	Min.	Max.	Unit
Operating Ambient Temperature Range (See Power Derating Curve)	-40	+92.5	°C
Case Temperature	---	+105	°C
Storage Temperature Range	-50	+125	°C
Humidity (non condensing)	---	95	% rel. H
Altitude	---	5000	m
Lead Temperature (1.5mm from case for 10Sec.)	---	260	°C

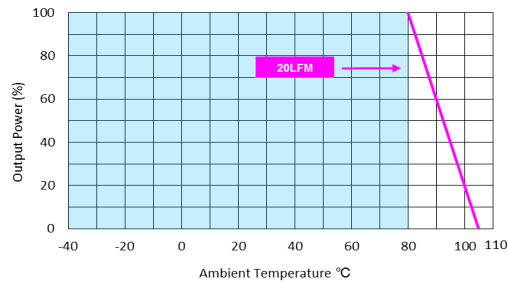
Power Derating Curve

Notes

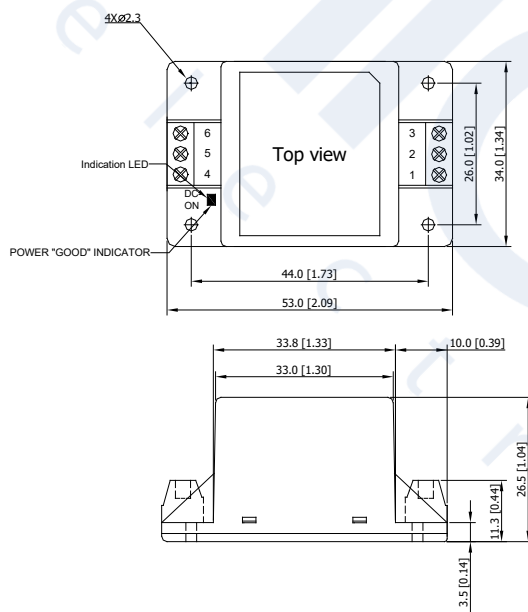
- 1 Specifications typical at Ta=+25°C, resistive load, nominal input voltage and rated output current unless otherwise noted.
- 2 Transient recovery time is measured to within 1% error band for a step change in output load of 75% to 100%.
- 3 We recommend to protect the converter by a slow blow fuse in the input supply line.
- 4 Other input and output voltage may be available, please contact factory.
- 5 Specifications are subject to change without notice.

Package Specifications
Mechanical Dimensions

Pin Connections

Pin	Single Output	Dual Output
1	Remote On/Off	Remote On/Off
2	-Vin	-Vin
3	+Vin	+Vin
4	-Vout	-Vout
5	NC	Common
6	+Vout	+Vout

NC: No Connection

- ▶ All dimensions in mm (inches)
- ▶ Tolerance: X.X±0.5 (X.XX±0.02)
X.XX±0.25 (X.XXX±0.01)

Physical Characteristics

Case Size	:	53.0x34.0x26.5mm (2.09x1.34x1.04 inches)
Case Material	:	Plastic resin (flammability to UL 94V-0 rated)
Weight	:	47.8 g

Package Specifications with DIN Rail Mounting Bracket (order code AC-DIN-04)

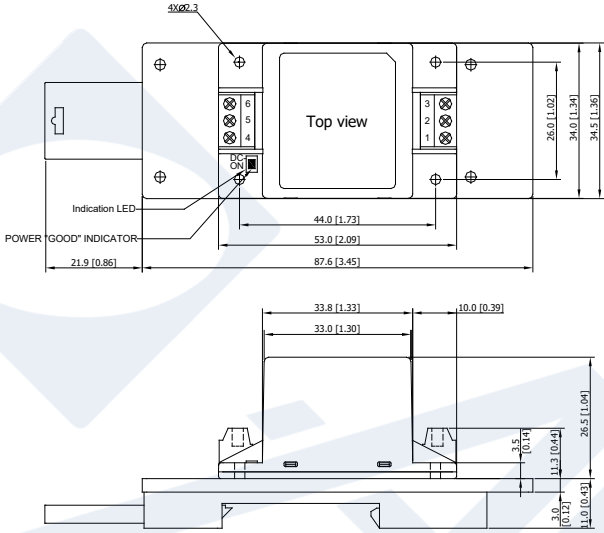
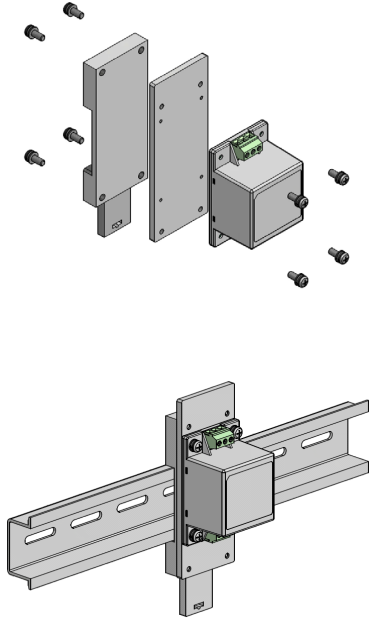
Mechanical Dimensions	DIN-Rail Mounting Kit
	

Physical Characteristics

Case Size	:	53.0x34.0x26.5mm (2.09x1.34x1.04 inches)
Case Material	:	Plastic resin (flammability to UL 94V-0 rated)
Weight	:	90.8g

Order Code Table

Standard	With DIN Rail Mounting by two Order Code	
MJA06-110S05C	MJA06-110S05C	AC-DIN-04
MJA06-110S051C	MJA06-110S051C	AC-DIN-04
MJA06-110S12C	MJA06-110S12C	AC-DIN-04
MJA06-110S15C	MJA06-110S15C	AC-DIN-04
MJA06-110S24C	MJA06-110S24C	AC-DIN-04
MJA06-110S48C	MJA06-110S48C	AC-DIN-04
MJA06-110D12C	MJA06-110D12C	AC-DIN-04
MJA06-110D15C	MJA06-110D15C	AC-DIN-04
MJA06-110D24C	MJA06-110D24C	AC-DIN-04

Test Setup

Peak-to-Peak Output Noise Measurement Test

Use a C_{out} 0.47 μF ceramic capacitor. Scope measurement should be made by using a BNC socket, measurement bandwidth is 0-20 MHz. Position the load between 50 mm and 75 mm from the DC-DC Converter.

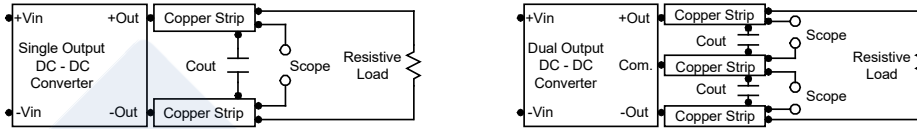

Technical Notes

Remote On/Off

Positive logic remote on/off turns the module on during a logic high voltage on the remote on/off pin, and off during a logic low. To turn the power module on and off, the user must supply a switch to control the voltage between the on/off terminal and the -Vin terminal. The switch can be an open collector or equivalent. A logic low is 0V to 1.2V. A logic high is 3.5V to 12V. The maximum sink current at the on/off terminal (Pin 1) during a logic low is -500 μA .

Overload Protection

To provide protection in a fault (output overload) condition, the unit is equipped with internal current limiting circuitry and can endure current limiting for an unlimited duration. At the point of current-limit inception, the unit shifts from voltage control to current control. The unit operates normally once the output current is brought back into its specified range.

Input Source Impedance

The power module should be connected to a low ac-impedance input source. Highly inductive source impedances can affect the stability of the power module. In applications where power is supplied over long lines and output loading is high, it may be necessary to use a capacitor at the input to ensure startup. Capacitor mounted close to the power module helps ensure stability of the unit, it is recommended to use a good quality low Equivalent Series Resistance (ESR < 1.0 Ω at 100 kHz) capacitor of a 1 μF for the 110V devices.

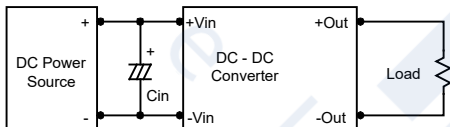

Output Ripple Reduction

A good quality low ESR capacitor placed as close as practicable across the load will give the best ripple and noise performance. To reduce output ripple, it is recommended to use 3.3 μF capacitors at the output.

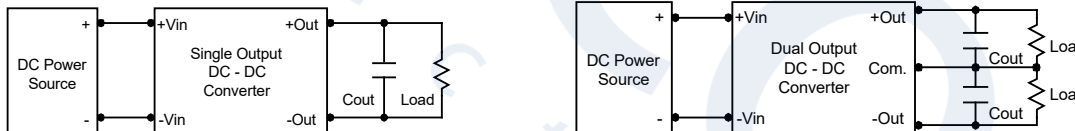

Maximum Capacitive Load

The MJA06C series has limitation of maximum connected capacitance at the output. The power module may be operated in current limiting mode during start-up, affecting the ramp-up and the startup time. The maximum capacitance can be found in the data sheet.

Thermal Considerations

Many conditions affect the thermal performance of the power module, such as orientation, airflow over the module and board spacing. To avoid exceeding the maximum temperature rating of the components inside the power module, the case temperature must be kept below 105°C.

The derating curves are determined from measurements obtained in a test setup.

