



MPM3690-20A/B

16V, Dual 13A or Single 26A DC/DC Power Module

DESCRIPTION

The MPM3690-20 is a dual 13A output or single 26A output power module that offers a complete power solution with excellent load and line regulation. The MPM3690-20 supports an input range between 4V and 16V and an output range between 0.6V and 3.3V. The voltage of the MPM3690-20's two outputs can be set separately via a single resistor at each output.

The MPM3690-20 offers two configurations. The MPM3690-20A is dual 13A output, while the MPM3690-20B is single 26A output. The MPM3690-20 is also pin-compatible with the MPM3690-30A/B (dual 18A or single 36A output) and MPM3690-50A/B (dual 25A or single 50A output) power modules. See the Ordering Information section on page 2 for more details.

The MPM3690-20 adopts MPS's proprietary, multi-phase constant-on-time (MCOT) control, which provides ultra-fast transient response and minimizes the output capacitance.

The MPM3690-20 integrates a monolithic DC/DC converter, power inductor, and other passive components. It is available in a BGA (16mmx16mmx5.18mm) package.

FEATURES

- Pin-Compatible Dual 13A or Single 26A Output Power Modules:
 - MPM3690-20A: Dual 13A Output
 - MPM3690-20B: Single 26A Output
- 4V to 16V Input Voltage Range
 - 3.2V to 16V Input Voltage Range with External 3.3V VCC Bias
- 0.6V to 3.3V Output Voltage Range
- Ultra-Fast Transient Enabled by COT Control
- Adjustable Switching Frequency
- Adjustable Soft-Start Time
- Over-Current and Over-Voltage Protection
- Differential Remote Sense for Both Output Channels
- Pin-Compatible with the MPM3690-30 and MPM3695-50
- Available in a BGA (16mmx16mmx5.18mm) Package

APPLICATIONS

- Telecom and Networking Equipment
- Industrial Equipment
- FPGA and ASIC Power Systems

All MPS parts are lead-free, halogen-free, and adhere to the RoHS directive. For MPS green status, please visit the MPS website under Quality Assurance. "MPS", the MPS logo, and "Simple, Easy Solutions" are trademarks of Monolithic Power Systems, Inc. or its subsidiaries.

TYPICAL APPLICATION

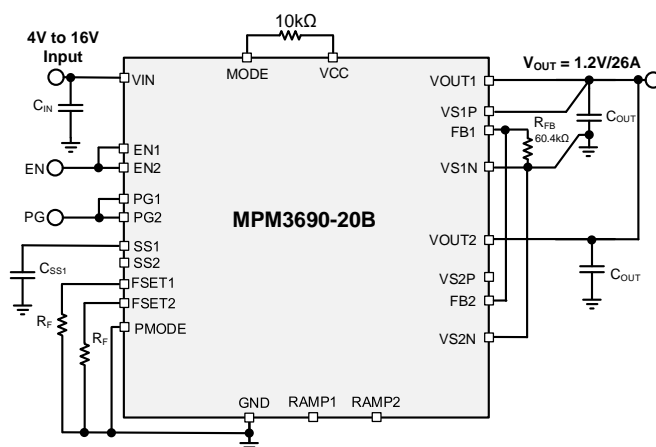
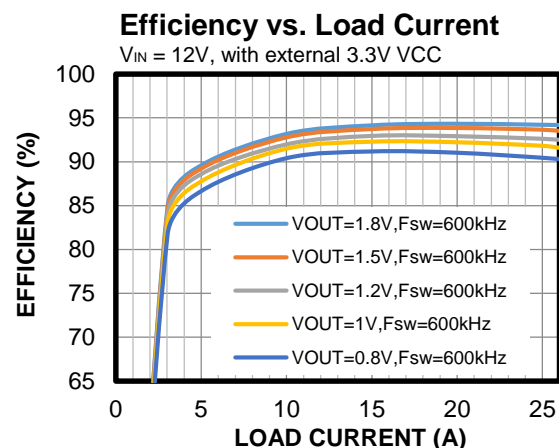

Figure 1: Interleaved Operation at 1.2V/26A



ORDERING INFORMATION

Part Number*	Configuration	Package	Top Marking	MSL_Rating
MPM3690GBF-20A	Dual 13A Output	BGA	See Below	3
MPM3690GBF-20B	Single 26A Output	(16mmx16mmx5.18mm)		

* For Tray, add suffix –T (e.g. MPM3690GBF-20A–T).

TOP MARKING (MPM3690GBF-20A)

MPS YYWW
M3690-20A
LLLLLLLLLL
M

MPS: MPS prefix
YY: Year code
WW: Week code
M3690-20A: part number
LLLLLLLLLL: Lot number
M: Module

TOP MARKING (MPM3690GBF-20B)

MPS YYWW
M3690-20B
LLLLLLLLLL
M

MPS: MPS prefix
YY: Year code
WW: Week code
M3690-20B: Part number
LLLLLLLLLL: Lot number
M: Module

PIN-COMPATIBLE PARTS

Part Number	Output	Description
MPM3690GBF-20A	Dual 13A	4V to 16V Input, 0.6V to 3.3V Output, BGA (16mmx16mmx5.18mm) Package
MPM3690GBF-20B	Single 26A	4V to 16V Input, 0.6V to 3.3V Output, BGA (16mmx16mmx5.18mm) Package
MPM3690GBF-30A	Dual 18A	4V to 16V Input, 0.6V to 3.3V Output, BGA (16mmx16mmx5.18mm) Package
MPM3690GBF-30B	Single 36A	4V to 16V Input, 0.6V to 3.3V Output, BGA (16mmx16mmx5.18mm) Package
MPM3690GBF-50A	Dual 25A	4V to 16V Input, 0.6V to 1.8V Output, BGA (16mmx16mmx5.18mm) Package
MPM3690GBF-50B	Single 50A	4V to 16V Input, 0.6V to 1.8V Output, BGA (16mmx16mmx5.18mm) Package

Order directly from MonolithicPower.com or our distributors.

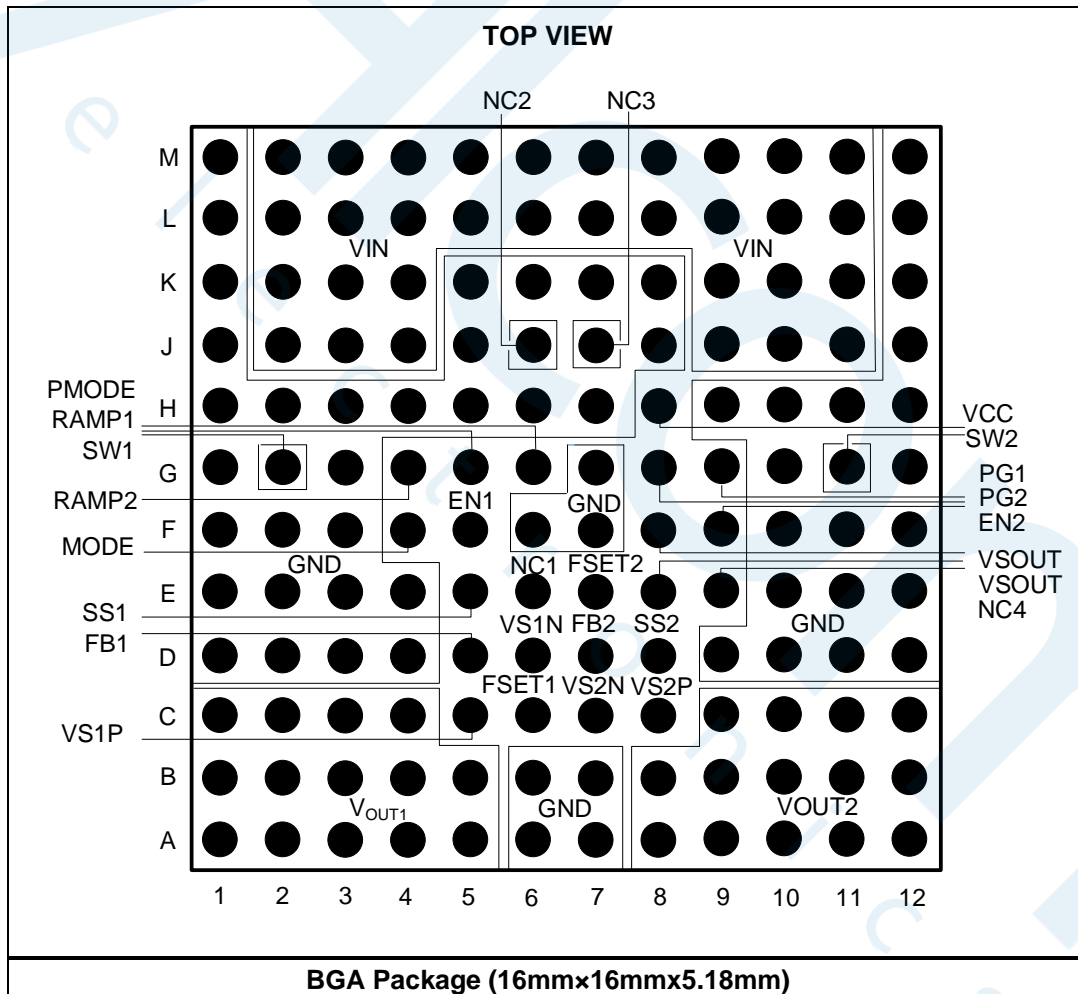
PACKAGE REFERENCE

PIN NUMBER LIST
Table 1: Pins A1~F12

Pin #	Function	Pin #	Function	Pin #	Function	Pin #	Function	Pin #	Function	Pin #	Function
A1	VOUT1	B1	VOUT1	C1	VOUT1	D1	GND	E1	GND	F1	GND
A2	VOUT1	B2	VOUT1	C2	VOUT1	D2	GND	E2	GND	F2	GND
A3	VOUT1	B3	VOUT1	C3	VOUT1	D3	GND	E3	GND	F3	GND
A4	VOUT1	B4	VOUT1	C4	VOUT1	D4	GND	E4	GND	F4	MODE
A5	VOUT1	B5	VOUT1	C5	VS1P	D5	FB1	E5	SS1	F5	EN1
A6	GND	B6	GND	C6	FSET1	D6	VS1N	E6	NC1	F6	GND
A7	GND	B7	GND	C7	VS2N	D7	FB2	E7	FSET2	F7	GND
A8	VOUT2	B8	VOUT2	C8	VS2P	D8	SS2	E8	VSOUT	F8	VSOUT
A9	VOUT2	B9	VOUT2	C9	VOUT2	D9	GND	E9	NC4	F9	EN2
A10	VOUT2	B10	VOUT2	C10	VOUT2	D10	GND	E10	GND	F10	GND
A11	VOUT2	B11	VOUT2	C11	VOUT2	D11	GND	E11	GND	F11	GND
A12	VOUT2	B12	VOUT2	C12	VOUT2	D12	GND	E12	GND	F12	GND

Table 2: Pins G1~M12

Pin #	Function	Pin #	Function	Pin #	Function	Pin #	Function	Pin #	Function	Pin #	Function
G1	GND	H1	GND	J1	GND	K1	GND	L1	GND	M1	GND
G2	SW1	H2	GND	J2	VIN	K2	VIN	L2	VIN	M2	VIN
G3	GND	H3	GND	J3	VIN	K3	VIN	L3	VIN	M3	VIN
G4	RAMP2	H4	GND	J4	VIN	K4	VIN	L4	VIN	M4	VIN
G5	RAMP1	H5	GND	J5	GND	K5	GND	L5	VIN	M5	VIN
G6	PMODE	H6	GND	J6	NC2	K6	GND	L6	VIN	M6	VIN
G7	GND	H7	GND	J7	NC3	K7	GND	L7	VIN	M7	VIN
G8	PG2	H8	VCC	J8	GND	K8	GND	L8	VIN	M8	VIN
G9	PG1	H9	GND	J9	VIN	K9	VIN	L9	VIN	M9	VIN
G10	GND	H10	GND	J10	VIN	K10	VIN	L10	VIN	M10	VIN
G11	SW2	H11	GND	J11	VIN	K11	VIN	L11	VIN	M11	VIN
G12	GND	H12	GND	J12	GND	K12	GND	L12	GND	M12	GND

PIN FUNCTIONS

Pin Number	Name	Description
A1–A5, B1–B5, C1–C4	VOUT1	Power output 1. These pins are the power output pins for channel 1.
A6, A7, B6–B7, D1–D4, D9–D12, E1–E4, E10, E11, E12, F1, F2, F3, F6, F7, F10, F11, F12, G1, G3, G7, G10, G12, H1–H7, H9–H12, J1, J5, J8, J12, K1, K5–K8, K12, L1, L12, M1, M12	GND	Power ground. GND is the ground of the regulated output voltage.
A8–A12, B8–B12, C9–C12	VOUT2	Power output 2. These pins are the power output pins for channel 2.
C5, C8	VS1P, VS2P	Positive input of the remote-sense amplifier. Connect these pins to the remote sense point of the output voltage.
D6, C7	VS1N, VS2N	Negative input of the remote-sense amplifier. Connect these pins to the remote sense point of the output GND to enable remote sense. Connect these pins directly to GND to disable the remote sense function.
C6, E7	FSET1, FSET2	Frequency setting. Connect a resistor between this pin and GND to configure the switching frequency between 400kHz and 1MHz. For the MPM3690-20B, the resistors placed at FSET1 and FSET2 must be the same value.
D5, D7	FB1, FB2	Feedback voltage. Connect a resistor between this pin and VS1N or VS2N to configure the output voltage. This pin is connected to VS1P or VS2P with a 60.4kΩ resistor.
E5, D8	SS1, SS2	Soft-start time setting. Connect a ceramic capacitor to these pins to set the soft-start time.
G5, G4	RAMP1, RAMP2	Ramp selection pin. Float these pins to set the internal compensation ramp to a high value. Pull these pins low to set the internal compensation ramp to a low value.
E8, F8	VSOUT	Not connected (internally floated). Float these pins.
F4	MODE	Operation mode setting. Pull MODE up to VCC for forced continuous conduction mode (FCCM).
F5, F9	EN1, EN2	Enable pins. Drive the EN pins high to turn the output on; drive the EN pins low to turn the output off. Do not float EN1 or EN2.
G2, G11	SW1, SW2	Switching nodes. Float these pins.
G6	PMODE	Protection mode selection. Connect PMODE to GND for latch-off mode. Pull PMODE up to VCC for retry (hiccup) mode.
G9, G8	PG1, PG2	Power good outputs. The output of the PG pins is an open drain. Pull the PG pins high with a pull-up resistor.
H8	VCC	Output of the internal power supply. Float this pin or connect it to an external 3.3V power supply to improve efficiency.
E6, J6, J7, E9	NC1, NC2, NC3, NC4	Not connected (internally floating). Float these pins.
M2–M11, L2–L11, J2, J3, J4, J9, J10, J11, K2, K3K4, K9, K10, K11	VIN	Supply voltage. Connect the input voltage between these pins and the GND pins.

ABSOLUTE MAXIMUM RATINGS ⁽¹⁾

Supply voltage (V_{IN})	18V
$V_{SW1/2}$ (DC)	-0.3 V to +18.3V
V_{CC}	4.5V
V_{CC} (1s) ⁽³⁾	6V
$V_{OUT1/2}$	5.5V
All other pins	-0.3V to +4.3V
All other pins (1s) ⁽³⁾	6V
Continuous power dissipation ($T_A = 25^\circ\text{C}$) ⁽²⁾	
.....	18.59W
Junction temperature	170°C
Lead temperature	260°C
Storage temperature	-65°C to +170°C

Recommended Operating Conditions ⁽³⁾

Supply voltage (V_{IN})	4V to 16V
Output voltage (V_{OUT})	0.6V to 3.3V
Operating junction temp (T_J)	-40°C to +125°C

Thermal Resistance ⁽⁴⁾	θ_{JA}	θ_{JC}
EVM3690-20B-BF-00A	7.8	4.1 .. °C/W

Notes:

- 1) Exceeding these ratings may damage the device.
- 2) The maximum allowable power dissipation is a function of the maximum junction temperature, T_J (MAX), the junction-to-ambient thermal resistance, θ_{JA} , and the ambient temperature, T_A . The maximum allowable continuous power dissipation at any ambient temperature is calculated by P_D (MAX) = $(T_J$ (MAX) - T_A) / θ_{JA} . Exceeding the maximum allowable power dissipation can produce an excessive die temperature, and the module may go into thermal shutdown. Internal thermal shutdown circuitry protects the device from permanent damage.
- 3) The device is not guaranteed to function outside of its operating conditions.
- 4) Measured on EVM3690-20B-BF-00A, 4-layer PCB, 10cmx10cm.

ELECTRICAL CHARACTERISTICS

$V_{IN} = 12V$, $T_J = -40^{\circ}C$ to $+125^{\circ}C$, unless otherwise noted.

Parameters	Symbol	Condition	Min	Typ	Max	Units
VIN Supply Current						
Supply current (quiescent)	I_{IN}	$EN = 0V$, $FB = 0.65V$ $R_{FREQ} = 30k\Omega$ to GND		1.5	2	mA
Output Current Limit						
Output current limit (inductor valley)	I_{LIM_VALLEY}	Individual phase current limit, $f_{SW} = 800kHz$, $V_{OUT} = 1.2V$		15.7		A
Low-side negative current limit	I_{LIM_NEG}	Individual phase current limit		-13		A
Frequency and Timer						
Switching frequency	f_{SW}	$R_{FREQ} = 30k\Omega$		800		kHz
Minimum on time ⁽⁵⁾	t_{ON_MIN}	$f_{SW} = 800kHz$, $V_{OUT} = 0.6V$		50		ns
Minimum off time ⁽⁵⁾	t_{OFF_MIN}			220		ns
Output Over-Voltage and Under-Voltage Protection						
OVP threshold	V_{OVP}		116%	120%	124%	V_{REF}
UVP threshold	V_{UVP}		70%	74%	79%	V_{REF}
EN						
Input High voltage	V_{IH_EN}		2.15			V
Input low voltage	V_{IL_EN}				1.20	V
Feedback Voltage						
Feedback accuracy			594	600	606	mV
Soft Start						
Soft-start current	I_{SS}		15	20	25	μA
Error Amplifier						
Feedback current	I_{FB}	$V_{FB} = 0.65V$		50	100	nA
Soft Shutdown						
Soft shutdown discharge FET	R_{ON_DISCH}	$T_J = 25^{\circ}C$		60	120	Ω
UVLO						
VCC under-voltage lockout rising threshold	V_{CCVTH_RISE}		2.6	2.75	2.9	V
VCC under-voltage lockout falling threshold	V_{CCVTH_FALL}		2.3	2.45	2.6	V
VCC output voltage	V_{CC}		3.1	3.25	3.4	V
Power Good (PG)						
Power good high threshold	$PG_{VTH_HI_RISE}$	FB from low to high	88.5%	92.5%	96.5%	V_{REF}
Power good low threshold	$PG_{VTH_LO_RISE}$	FB from low to high	116%	120%	124%	V_{REF}
	$PG_{VTH_LO_FALL}$	FB from high to low	70%	74%	78%	V_{REF}
Power good sink current capability	V_{PG}	$I_{PG} = 10mA$			0.3	V
Power good leakage current	I_{PG_LEAK}	$V_{PG} = 3V$, $T_J = 25^{\circ}C$		1.5	2.5	μA

ELECTRICAL CHARACTERISTICS (continued)
 $V_{IN} = 12V$, $T_J = -40^{\circ}C$ to $+125^{\circ}C$, unless otherwise noted.

Parameters	Symbol	Condition	Min	Typ	Max	Units
Power good low-level output voltage	V_{OL_100}	$V_{IN} = 0V$, pull PG up to 3.3V through a 100k Ω resistor, $T_J = 25^{\circ}C$		600	720	mV
	V_{OL_10}	$V_{IN} = 0V$, pull PG up to 3.3V through a 10k Ω resistor, $T_J = 25^{\circ}C$		700	820	
Thermal Protection						
Thermal shutdown threshold ⁽⁵⁾				160		$^{\circ}C$
Thermal hysteresis threshold ⁽⁵⁾				30		$^{\circ}C$

Note:

5) Guaranteed by sample characterization. Not tested in production. The parameter is tested during parameter characterization.

TYPICAL PERFORMANCE CHARACTERISTICS

MPM3690-20A, $V_{IN} = 12V$, $V_{OUT1} = V_{OUT2} = 1.2V$, $C_{OUT1} = C_{OUT2} = 690\mu F$, $f_{SW1} = f_{SW2} = 500kHz$, FCCM, $T_A = 25^\circ C$, unless otherwise noted.

Efficiency vs. Load Current

$V_{IN} = 12V$, with internal 3.3V VCC

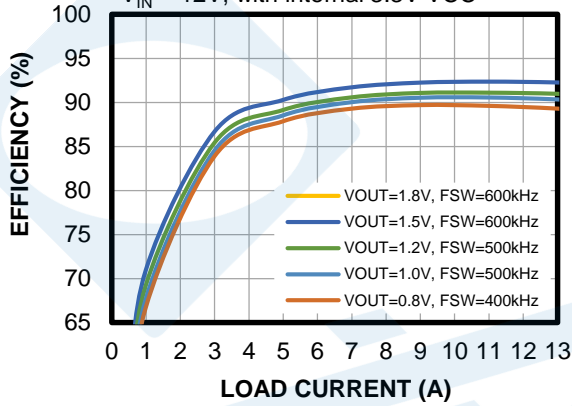

Efficiency vs. Load Current

$V_{IN} = 5V$, with internal 3.3V VCC

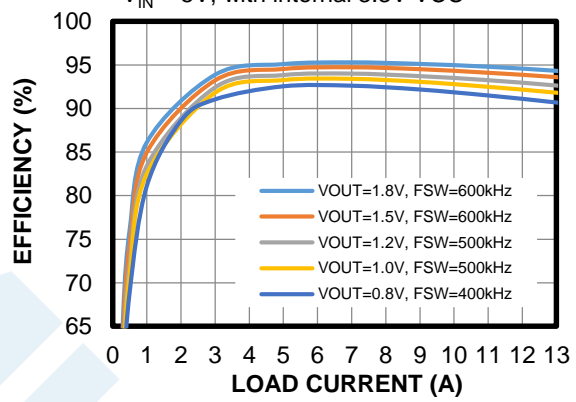

Efficiency vs. Load Current

$V_{IN} = 12V$, with external 3.3V VCC

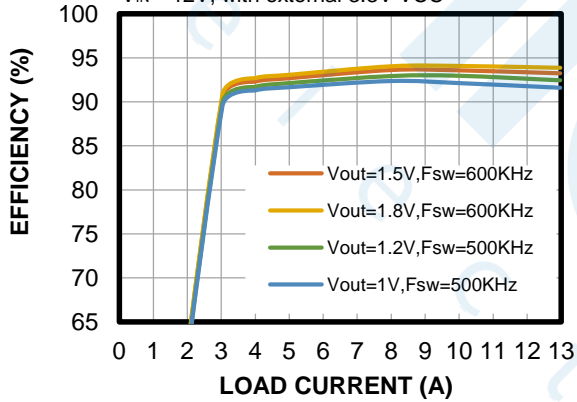

Load Regulation

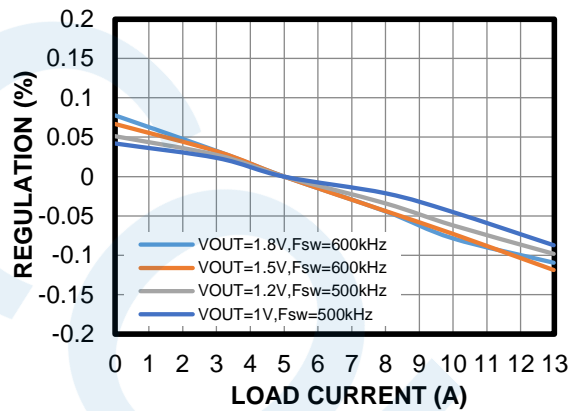

Line Regulation

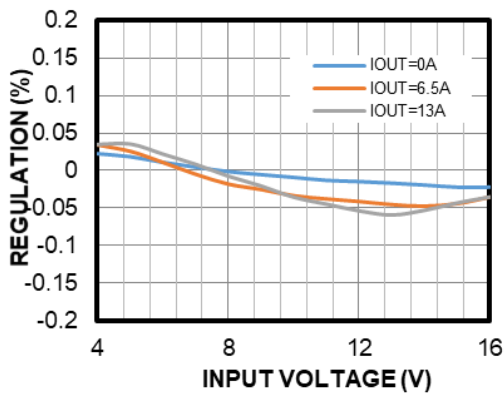

TYPICAL PERFORMANCE CHARACTERISTICS *(continued)*

MPM3690-20A, $V_{IN} = 12V$, $V_{OUT1} = V_{OUT2} = 1.2V$, $C_{OUT1} = C_{OUT2} = 690\mu F$, $f_{SW1} = f_{SW2} = 500kHz$, FCCM, $T_A = 25^\circ C$, unless otherwise noted.

Ripple

$I_{OUT1} = I_{OUT2} = 0A$

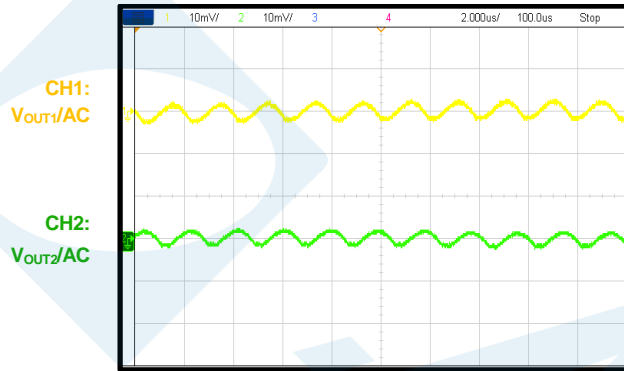

Ripple

$I_{OUT1} = I_{OUT2} = 13A$

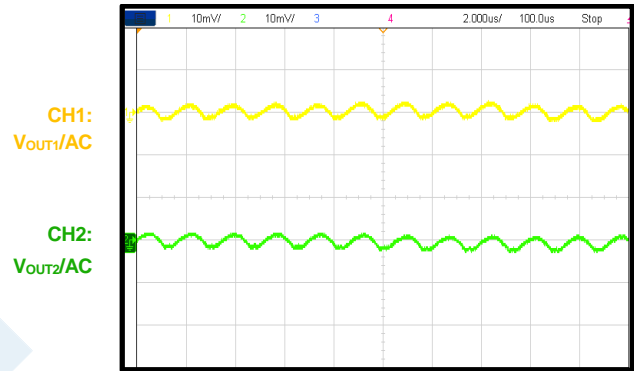

Start-Up through VIN

$I_{OUT1} = I_{OUT2} = 0A$

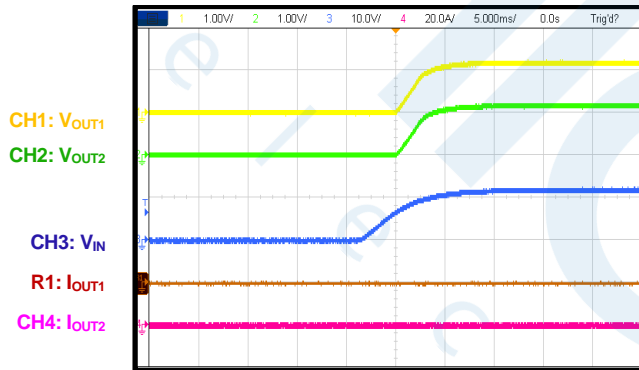

Start-Up through VIN

$I_{OUT1} = I_{OUT2} = 13A$

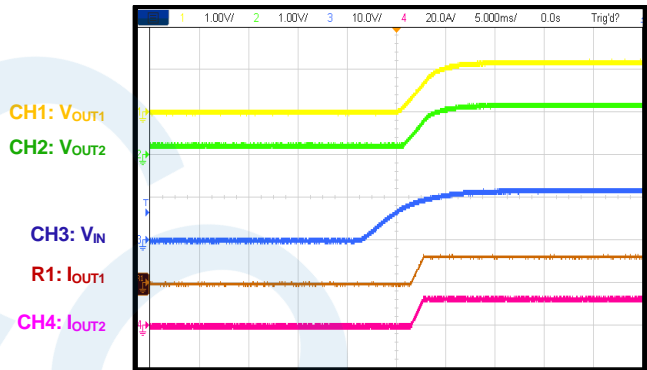

Shutdown through VIN

$I_{OUT1} = I_{OUT2} = 0A$

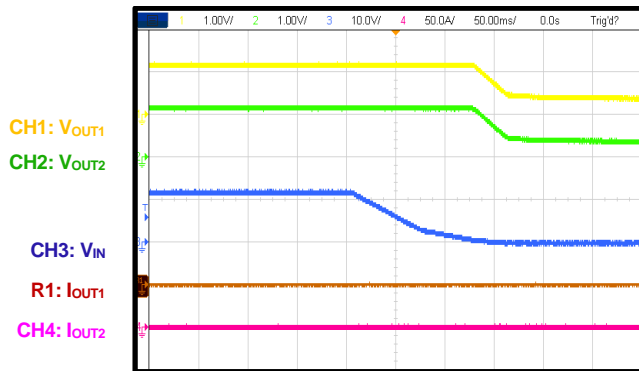

Shutdown through VIN

$I_{OUT1} = I_{OUT2} = 13A$

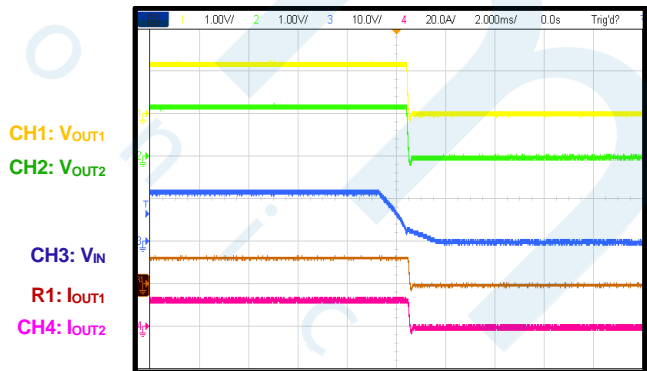

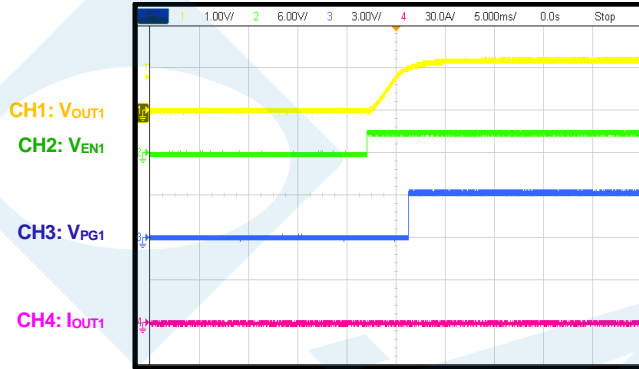
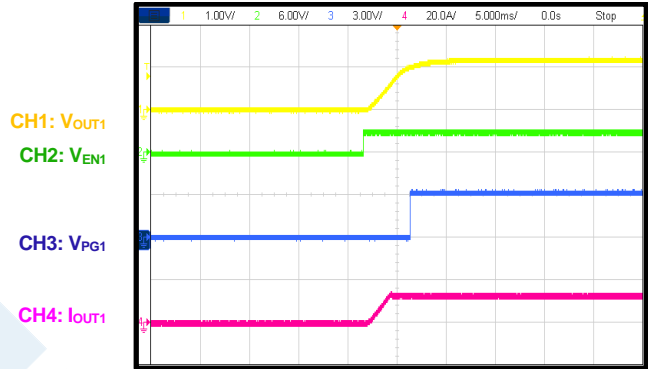
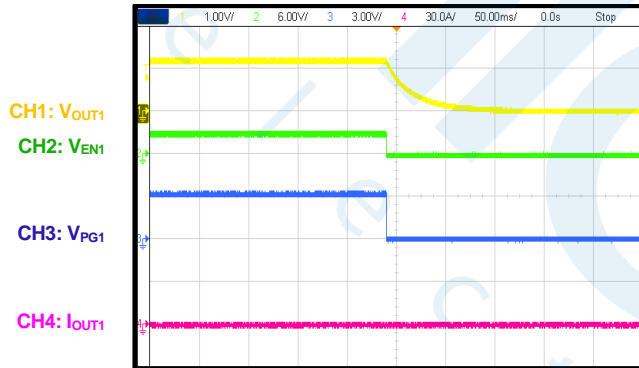
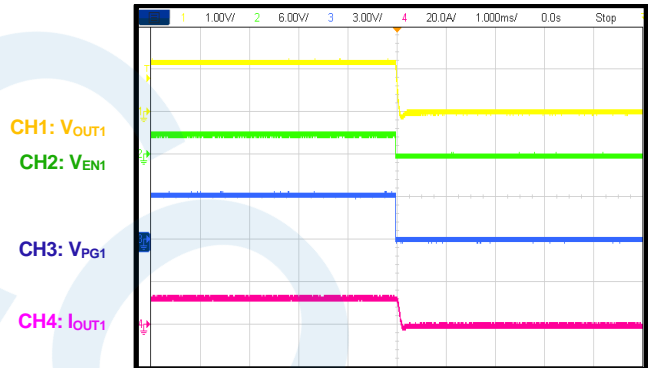
TYPICAL PERFORMANCE CHARACTERISTICS (continued)
MPM3690-20A, $V_{IN} = 12V$, $V_{OUT1} = V_{OUT2} = 1.2V$, $C_{OUT1} = C_{OUT2} = 690\mu F$, $f_{SW1} = f_{SW2} = 500kHz$, FCCM, $T_A = 25^\circ C$, unless otherwise noted.
Start-Up through EN
 $I_{OUT1} = 0A$

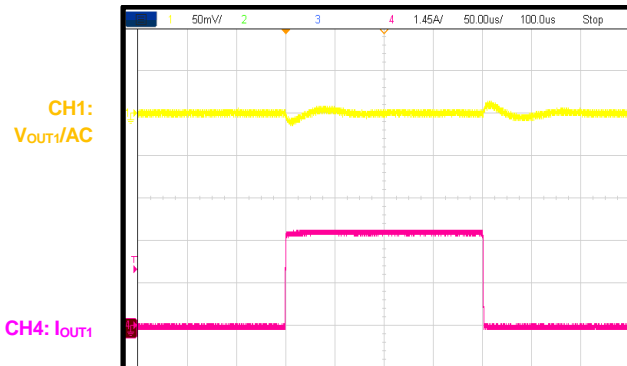
Start-Up through EN
 $I_{OUT1} = 13A$

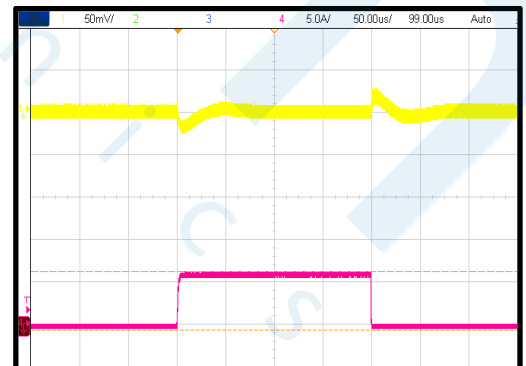
Shutdown through EN
 $I_{OUT1} = 0A$

Shutdown through EN
 $I_{OUT1} = 13A$

Load Transient

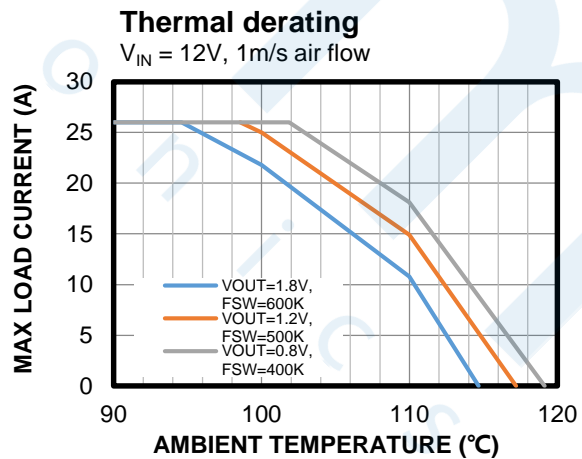
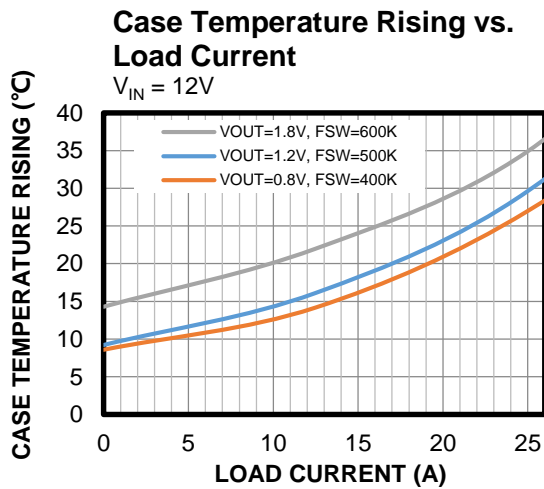
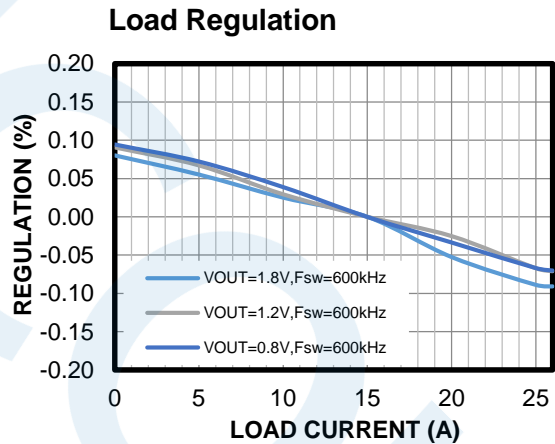
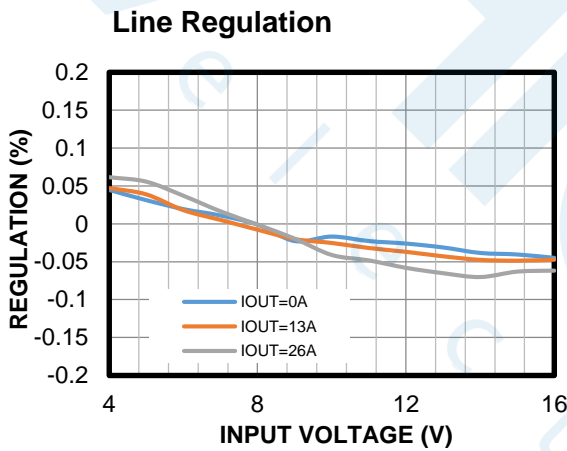
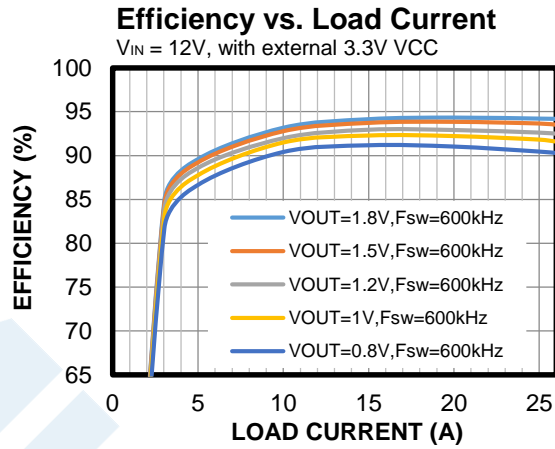
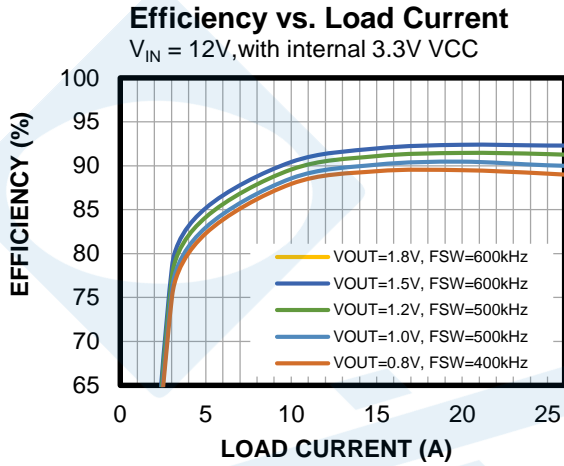
 3.25A load step, $10A/\mu s$, $C_{OUT} = 10 \times 47\mu F$, ceramic + $220\mu F$ POSCAP, $C_{FF} = 33nF$, high ramp

Load Transient

 6.5A load step, $10A/\mu s$, $C_{OUT} = 10 \times 47\mu F$ ceramic + $220\mu F$ POSCAP, $C_{FF} = 33nF$, high ramp

TYPICAL PERFORMANCE CHARACTERISTICS (continued)

MPM3690-20B, $V_{IN} = 12V$, $V_{OUT} = 1.2V$, $C_{OUT} = 1380\mu F$, $f_{SW} = 500kHz$, FCCM, $T_A = 25^\circ C$, unless otherwise noted.

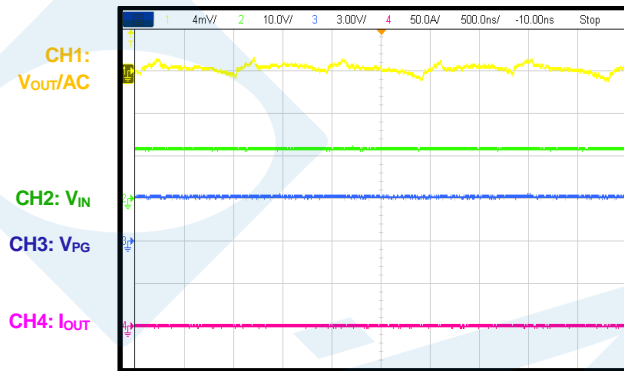
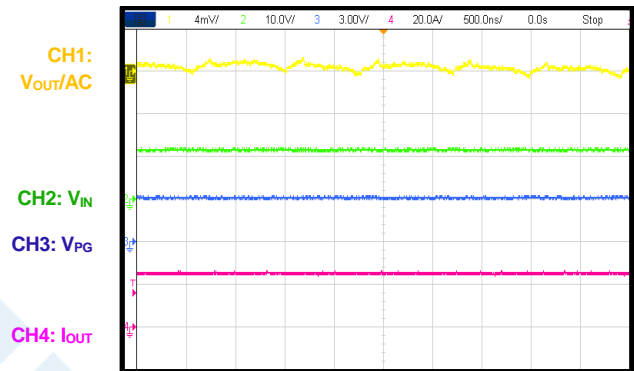
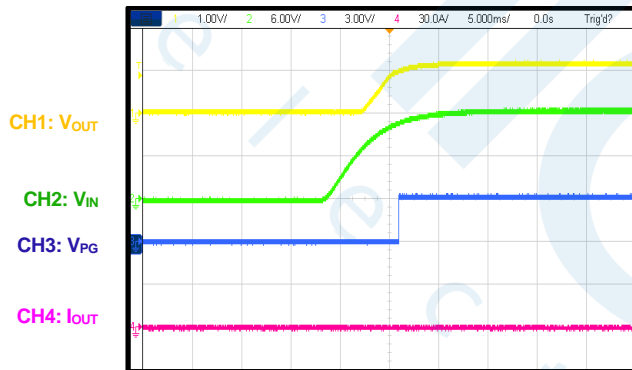
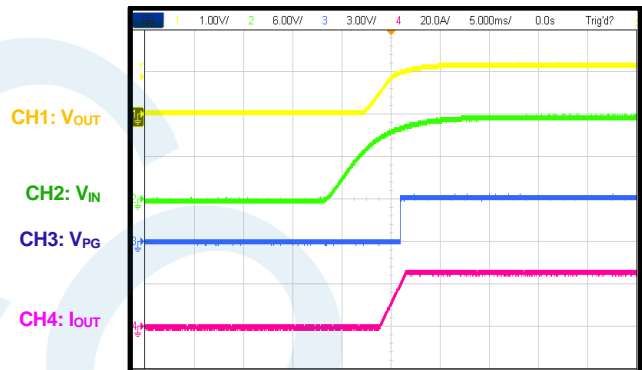
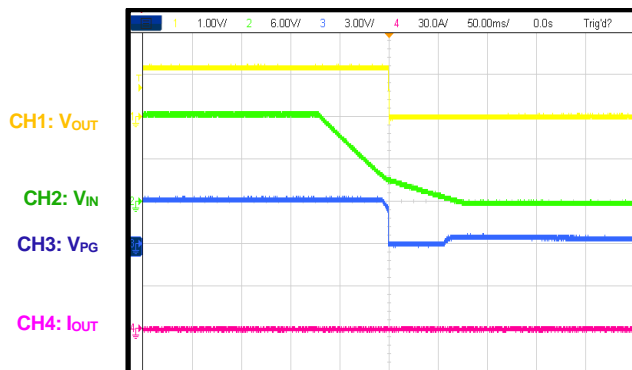
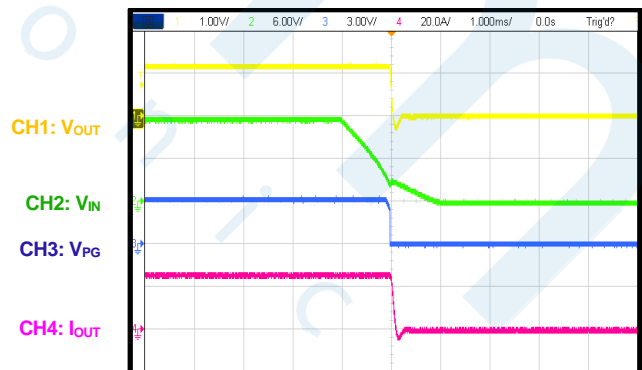

TYPICAL PERFORMANCE CHARACTERISTICS (continued)
MPM3690-20B, $V_{IN} = 12V$, $V_{OUT} = 1.2V$, $C_{OUT} = 1380\mu F$, $f_{SW} = 500kHz$, FCCM, $T_A = 25^\circ C$, unless otherwise noted.
Ripple
 $I_{OUT} = 0A$, $C_{OUT} = 20 \times 47\mu F$ ceramic + 2 x 220 μF POSCAP

Ripple
 $I_{OUT} = 26A$, $C_{OUT} = 20 \times 47\mu F$ ceramic + 2 x 220 μF POSCAP

Start-Up through VIN
 $I_{OUT} = 0A$

Start-Up through VIN
 $I_{OUT} = 26A$

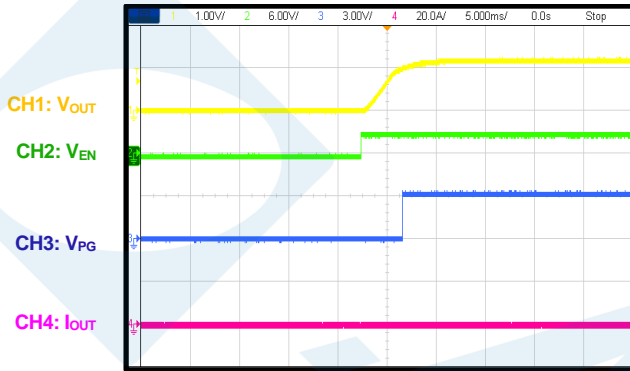
Shutdown through VIN
 $I_{OUT} = 0A$

Shutdown through VIN
 $I_{OUT} = 26A$

TYPICAL PERFORMANCE CHARACTERISTICS (continued)

MPM3690-20B, $V_{IN} = 12V$, $V_{OUT} = 1.2V$, $C_{OUT} = 1380\mu F$, $f_{SW} = 500kHz$, FCCM, $T_A = 25^\circ C$, unless otherwise noted.

Start-Up through EN
 $I_{OUT} = 0A$



Start-Up through EN
 $I_{OUT} = 26A$

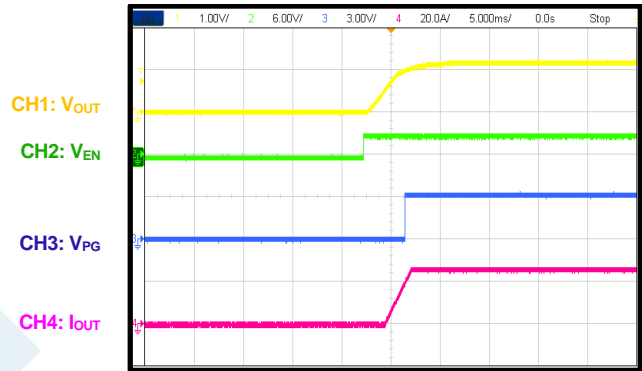

Shutdown through EN
 $I_{OUT} = 0A$

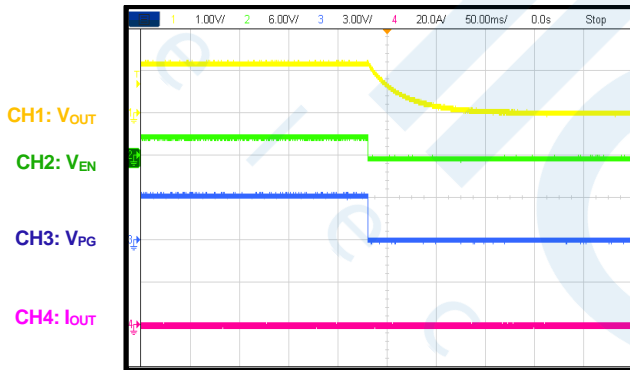

Shutdown through EN
 $I_{OUT} = 26A$

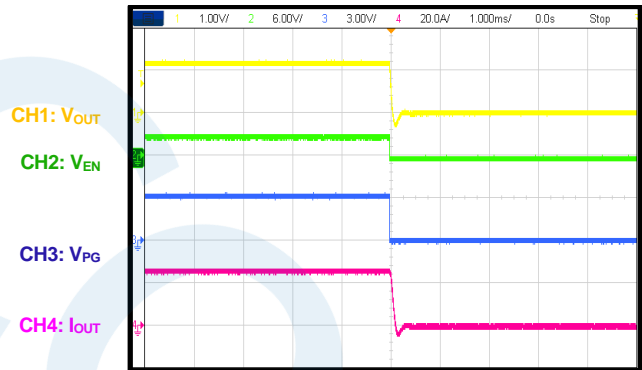

Load Transient

6.5A load step, $10A/\mu s$, $C_{OUT} = 20 \times 47\mu F$ ceramic + $2 \times 220\mu F$ POSCAP, $C_{FF} = 33nF$, high ramp

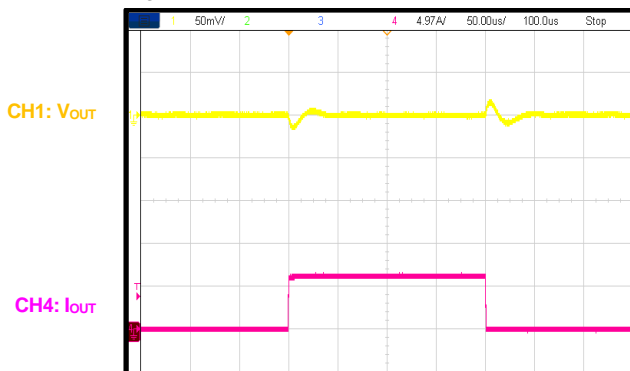

Load Transient

13A Load Step, $10A/\mu s$, $C_{OUT} = 20 \times 47\mu F$ ceramic + $2 \times 220\mu F$ POSCAP, $C_{FF} = 33nF$, high ramp

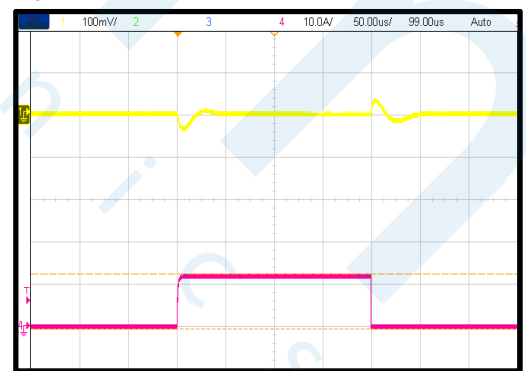

FUNCTIONAL BLOCK DIAGRAMS

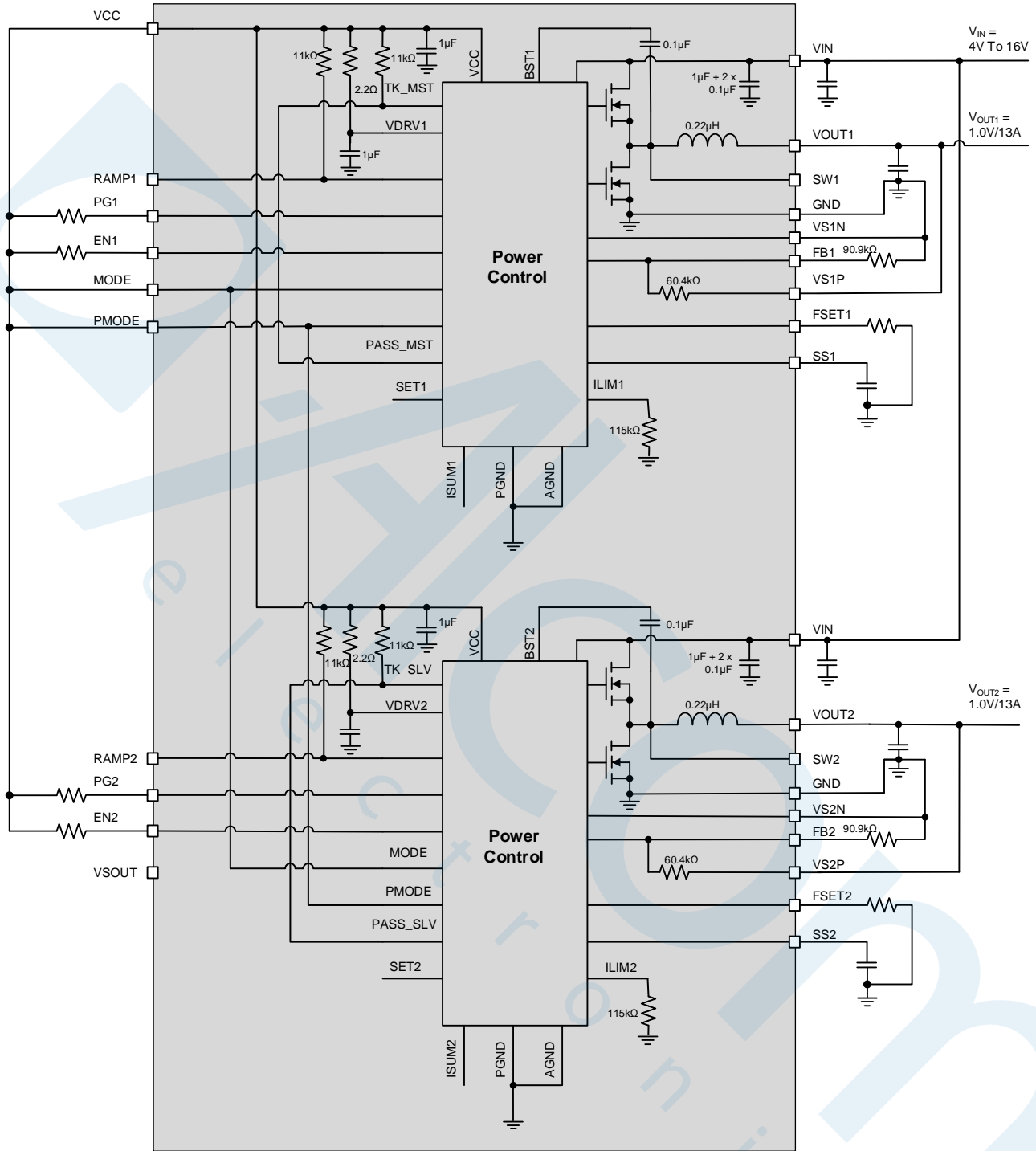

Figure 2: MPM3690-20A Functional Block Diagram

FUNCTIONAL BLOCK DIAGRAMS (continued)

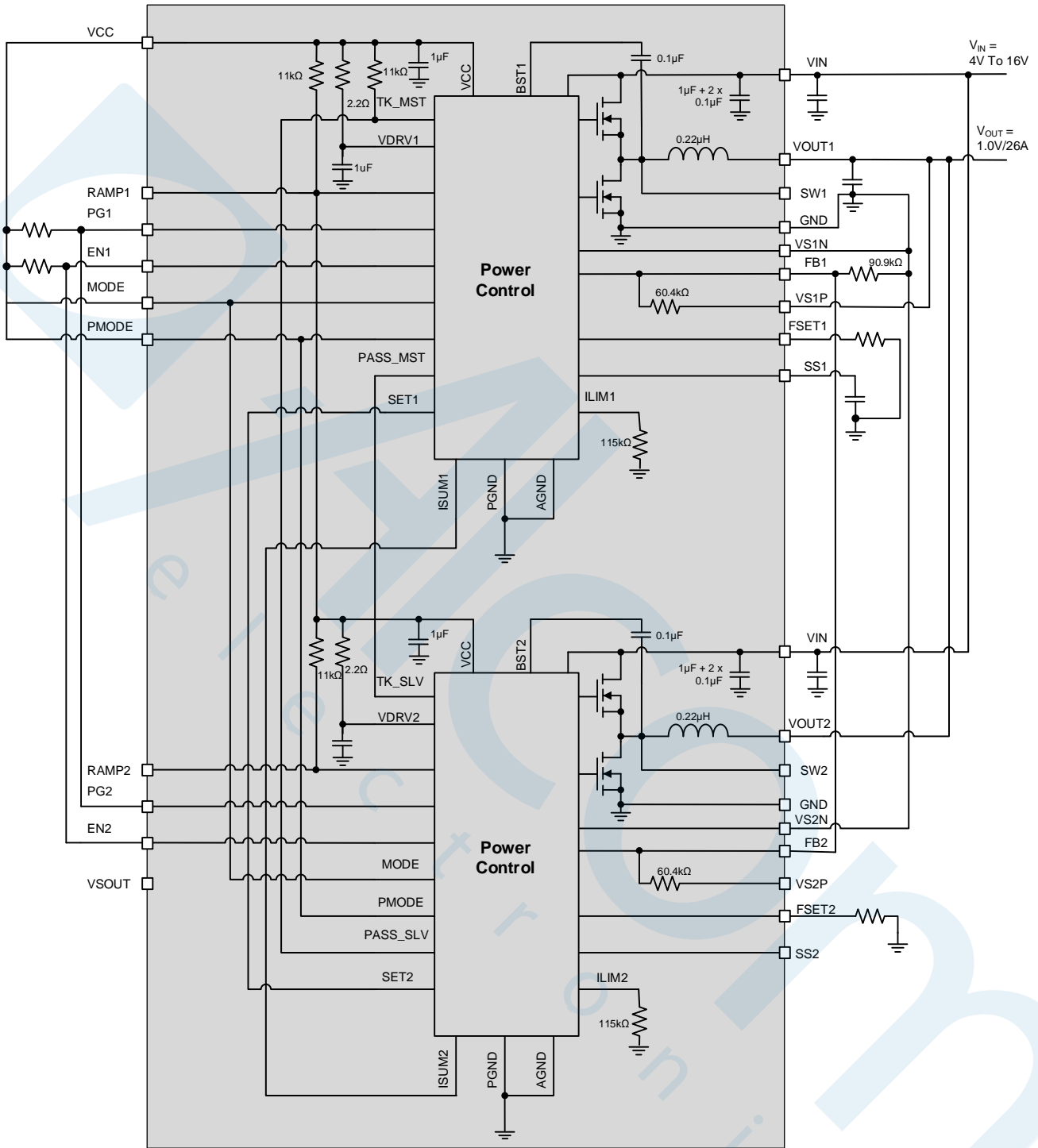

Figure 3: MPM3690-20B Functional Block Diagram

OPERATION

The MPM3690-20 is a dual 13A output or single 26A output power module that integrates two inductors and two monolithic power ICs. The MPM3690-20 utilizes constant-on-time (COT) control to provide a fast transient response.

Multi-Phase Operation

The MPM3690-20B adopts multi-phase constant-on-time (MCOT) control. MCOT control configures the two ICs for master and slave functionality. For the MPM3690-20B, the supply voltage (V_{IN}) slew rate during start-up must exceed 2V/ms.

MCOT Operation: Master Phase

The master phase performs the following functions:

- Generates the SET signal.
- Manages start-up, shutdown, and all of the protection functions.
- Monitors fault alerts from the slave phases through the PG pin.
- Generates the first on pulse.
- Generates the on pulse when receiving RUN and SET signals.
- Determines the on pulse width of its own phase based on the per-phase and total current.
- Sends the PASS and TAKE signals.

MCOT Operation: Slave Phases

The slave phases perform the following functions:

- Receive SET signal(s) from a master phase.
- Start the on pulse when receiving RUN and SET signals.
- Send over-voltage (OV), under-voltage (UV), and over-temperature (OT) alerts to the master phase through the PG pin.
- Determine the on pulse width of its own phase based on the per-phase and total current.
- Sends the PASS and TAKE signals.

MCOT control allows the MPM3690-20B to quickly respond to a load step transient when

compared to the traditional current mode control scheme.

When a load step-up occurs, the FB signal is lower than the internal reference. Meanwhile, the SET signal is generated more frequently than it is during steady state operation to respond to the load transient. Depending on the size of the load transient step and the slew rate, the SET signal can be generated within a minimum 50ns interval. This means that the next phase can turn on only 50ns after the previous phase has turned on to provide ultra-fast load transient response.

RAMP Compensation

The MPM3690-20 can operate with various output capacitors by using internal ramp compensation. The RAMP pin selects the ramp value. Float RAMP for large ramp compensation. Connect RAMP to ground for small ramp compensation. The RAMP signal is superimposed onto the FB signal.

When the superimposed ($RAMP + V_{FB}$) signal reaches the internal reference signal, a new SET signal is generated. This SET signal then generates a PWM on pulse.

A larger RAMP signal reduces system jitter but results in a slower load transient response, and vice versa. Optimize ramp compensation based on the application and design target.

Mode Setting

The MPM3690-20 only supports forced continuous conduction mode (FCCM). Set the MODE pin to logic high to force the device to operate in FCCM.

Soft Start (SS)

The MPM3690-20A features an adjustable soft-start time for both output channels. The soft-start time can be configured by connecting a capacitor (C_{SS}) between the SS pin and GND. The soft-start time can be calculated with Equation (1):

$$t_{SS}(\text{ms}) = 30 \times C_{SS}(\mu\text{F}) \quad (1)$$

Switching Frequency

The MPM3690-20A features an adjustable switching frequency for both output channels.

For the MPM3690-20B, the FREQ resistor for both channels must be the same value. The switching frequency (f_{sw}) can be configured by connecting a resistor between the FREQ pin and GND. f_{sw} can be estimated with Equation (2):

$$f_{sw}(\text{MHz}) = \frac{24}{R_T(\text{k}\Omega)} \quad (2)$$

Output Voltage Discharge

When the MPM3690-20 is disabled through the EN pin, the output voltage discharge function is enabled. Both the high-side MOSFET (HS-FET) and low-side MOSFET (LS-FET) latch off. A discharge FET connected between SW and GND turns on to discharge the output voltage. The typical switch on resistance of this FET is about 50Ω. Once the V_{FB} drops below 10% of V_{REF} , the discharge FET turns off.

Protection Mode Selection (PMODE)

The MPM3690-20 has a protection mode selection function via the PMODE pin. For hiccup mode, drive PMODE high if over-current protection (OCP), over-voltage protection (OVP), or over-temperature protection (OTP) is triggered. For latch-off mode, pull PMODE to GND if one of the above protections occur.

Inductor Valley Over-Current Protection (OCP)

The MPM3690-20 features an on-die current sense. When the LS-FET is on, the SW current (inductor current) is sensed and monitored cycle by cycle. When V_{FB} drops below V_{REF} , the HS-FET can only turn on if the LS-FET does not detect an over-current (OC) condition while the LS-FET is on. This is cycle-by-cycle current limiting.

There must be 31 consecutive cycles of an OC condition or an output short-circuit condition to trigger OCP. If the output voltage falls below the under-voltage protection (UVP) threshold, the device initiates OCP immediately.

If OCP is triggered, the device enters latch-off mode or hiccup mode depending on the PMODE pin. If the device latches off, it can only be re-enabled by recycling power on VCC or VIN.

Negative Inductor Current limit

If the LS-FET detects a negative current below the negative current limit, the device turns off the

LS-FET for a certain period to limit the negative current.

Over-Temperature Protection (OTP)

The MPM3690-20 features over-temperature protection (OTP). The IC internally monitors the junction temperature. If the junction temperature exceeds the OTP threshold, the converter shuts off.

After OTP is triggered, the device enters latch-off mode or hiccup mode. If the device latches off, it can only be re-enabled by recycling power on VCC or EN.

Feedback Circuit

For the MPM3690-20A, connect a resistor between FB1 and VS1N, then FB2 and VS2N, to set the device's output voltages. For the MPM3690-20B, connect a resistor between FB1 and VS1N to set the output voltage, then tie FB1 to FB2.

A 60.4kΩ resistor is connected between FB1 and VS1P, and between FB2 and VS2P (see Figure 2 on page 15). Figure 4 shows the feedback circuit.

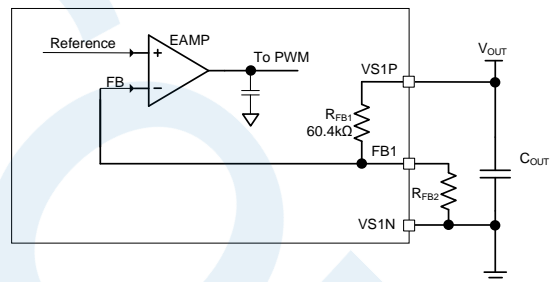

Figure 4: Feedback Circuit of the MPM3690-20

V_{OUT} can be calculated with Equation (3):

$$V_{OUT} = V_{REF} \times \left(1 + \frac{R_{FB1}}{R_{FB2}}\right) \quad (3)$$

Where V_{REF} is the reference voltage (about 0.6V), and $R_{FB1} = 60.4\text{k}\Omega$.

Power Good (PG)

The MPM3690-20A has a power good (PG) output for each channel. The PG pin is the open drain of a MOSFET. Connect PG to VCC or to an external voltage source that measures less than 3.6V through a pull-up resistor (typically 100kΩ). After applying the input voltage, the MOSFET turns on so that the PG pin is pulled to GND before soft start is complete.

After V_{FB} reaches the power good high threshold, the PG pin is pulled high after a delay. If the converter encounters any fault (e.g. under-voltage, over-voltage, over-temperature, or under-voltage lockout), the PG pin is latched low. After PG is latched low, it cannot be pulled high until a new soft start is initialized.

If the input supply fails to power the MPM3690-20, PG is clamped low, even if PG is tied to an external DC source through a pull-up resistor. Figure 5 shows the relationship between the PG voltage and the pull-up current.

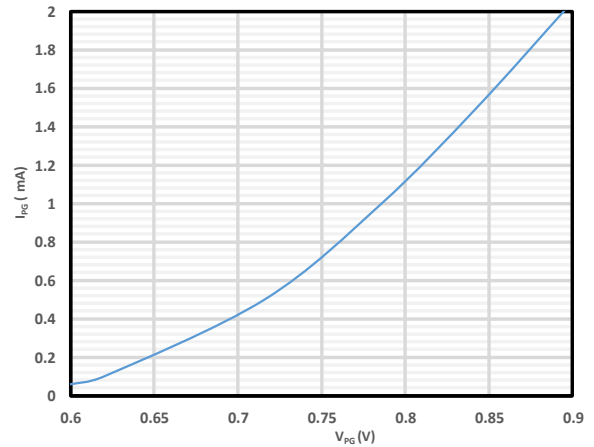

Figure 5: PG current vs. PG voltage

APPLICATION INFORMATION

Selecting the Input Capacitor

The step-down converter has a discontinuous input current, and requires a capacitor to supply the AC current to the converter while maintaining the DC input voltage. Use ceramic capacitors for the best performance. When designing the layout, place the input capacitors as close to the VIN pin as possible.

The capacitance can vary significantly with temperature. Use ceramic capacitors with X5R and X7R dielectrics because they are fairly stable across a wide temperature range.

The capacitors must also have a ripple current rating that exceeds the converter's maximum input ripple current. Estimate the input ripple current with Equation (4):

$$I_{CIN} = I_{OUT} \times \sqrt{\frac{V_{OUT}}{V_{IN}} \times \left(1 - \frac{V_{OUT}}{V_{IN}}\right)} \quad (4)$$

The worst-case condition occurs at $V_{IN} = 2V_{OUT}$, calculated with Equation (5):

$$I_{CIN} = \frac{I_{OUT}}{2} \quad (5)$$

For simplification, choose an input capacitor with an RMS current rating that exceeds half the maximum load current.

The input capacitance determines the converter's input voltage ripple. Select a capacitor value that meets any input voltage ripple requirements.

Estimate the input voltage with Equation (6):

$$\Delta V_{IN} = \frac{I_{OUT}}{f_{sw} \times C_{IN}} \times \frac{V_{OUT}}{V_{IN}} \times \left(1 - \frac{V_{OUT}}{V_{IN}}\right) \quad (6)$$

The worst-case condition occurs at $V_{IN} = 2V_{OUT}$, calculated with Equation (7):

$$\Delta V_{IN} = \frac{1}{4} \times \frac{I_{OUT}}{f_{sw} \times C_{IN}} \quad (7)$$

Selecting the Output Capacitor

The output capacitor maintains the DC output voltage. The output voltage ripple can be estimated with Equation (8):

$$\Delta V_{OUT} = \frac{V_{OUT}}{f_{sw} \times L} \times \left(1 - \frac{V_{OUT}}{V_{IN}}\right) \times \left(R_{ESR} + \frac{1}{8 \times f_{sw} \times C_{OUT}}\right) \quad (8)$$

When using ceramic capacitors, the capacitance dominates the impedance at the switching frequency and causes most of the output voltage ripple. For simplification, calculate the output voltage ripple with Equation (9):

$$\Delta V_{OUT} = \frac{V_{OUT}}{8 \times f_{sw}^2 \times L \times C_{OUT}} \times \left(1 - \frac{V_{OUT}}{V_{IN}}\right) \quad (9)$$

When using capacitors with a larger ESR (e.g. POSCAP or OSCON capacitors), the ESR dominates the impedance at the switching frequency. This means that the output voltage ripple is determined by the ESR. For simplification, the output ripple can be estimated with Equation (10):

$$\Delta V_{OUT} = \frac{V_{OUT}}{f_{sw} \times L} \times \left(1 - \frac{V_{OUT}}{V_{IN}}\right) \times R_{ESR} \quad (10)$$

Low VIN Applications

For applications with a low input voltage (V_{IN}) between 3.0V and 4.0V, an external VCC bias power supply is required. The external supply must exceed 2.9V, which is the under-voltage lockout (UVLO) rising threshold.

PCB Layout Guidelines

V_{IN}

Place sufficient decoupling capacitors as close as possible to the V_{IN} and GND pins. Sufficient GND vias should be placed around the GND pad of the decoupling capacitors. Avoid placing sensitive signal traces close to the input copper plane and/or vias without sufficient ground shielding. A minimum of four 22μF/25V ceramic capacitors are recommended at the input channel to provide sufficient decoupling.

V_{OUTx}

Connect each V_{OUTx} pin together on a copper plane. Place sufficient vias near the V_{OUTx} pads to provide a current path with minimal parasitic impedance. For the MPM3690-20B, combine all

the corresponding V_{OUT} copper planes.

GND

Connect all GND pins of the module on a copper plane. Place sufficient vias close to the GND pins to provide a current return path with minimal thermal resistance and parasitic impedance.

V_{SxP} and V_{SxN}

For the MPM3690-20A, route each pair of V_{SxP/N} pins as differential signals. For MPM3690-20B, connect FB1 to FB2, then connect all V_{SxN} pins. Avoid routing the V_{SxP/N} traces close to the input plane and high-speed signals.

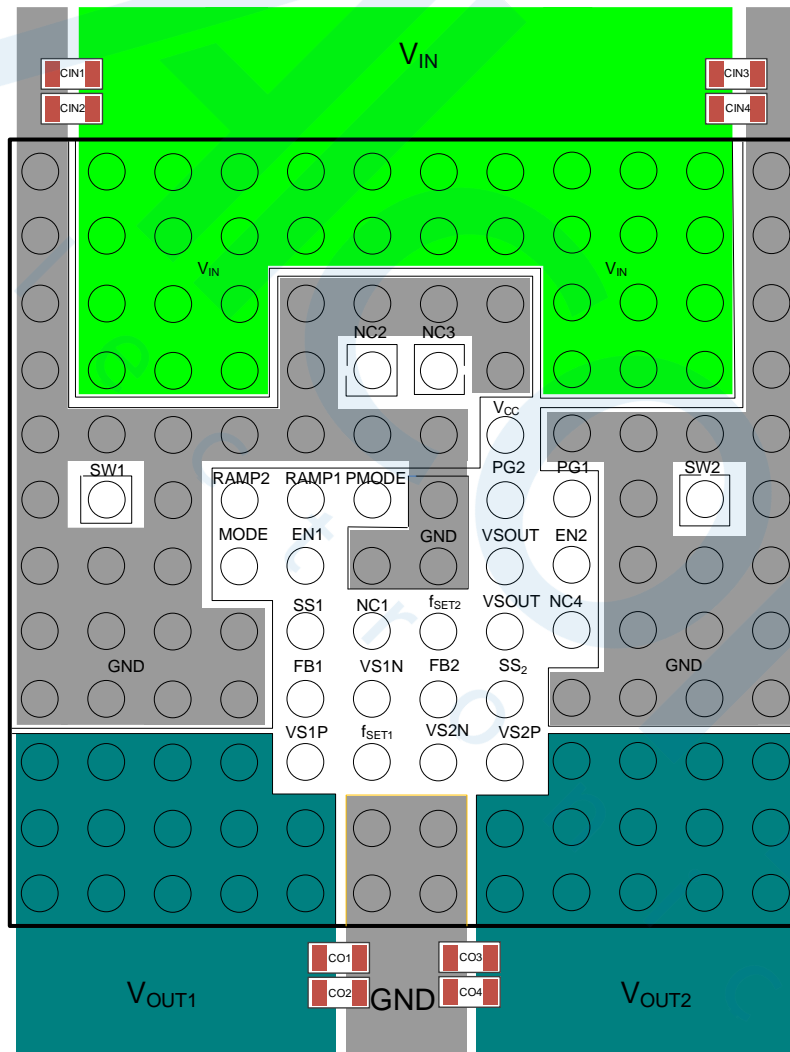

Figure 6: Recommended PCB Layout

TYPICAL APPLICATION CIRCUITS

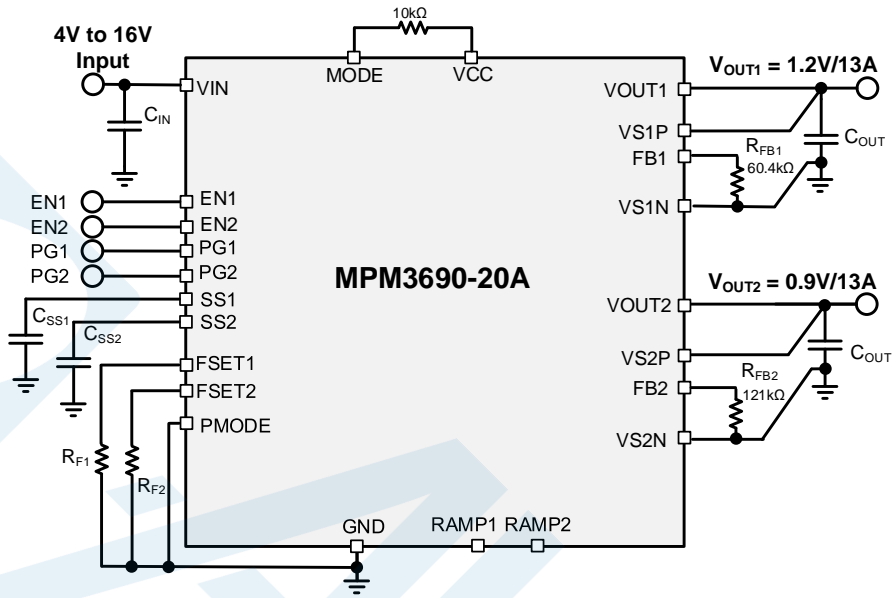

Figure 7: Dual-Output Operation, 1.2V and 0.9V at 13A (Remote Sense Enabled for Both Outputs)

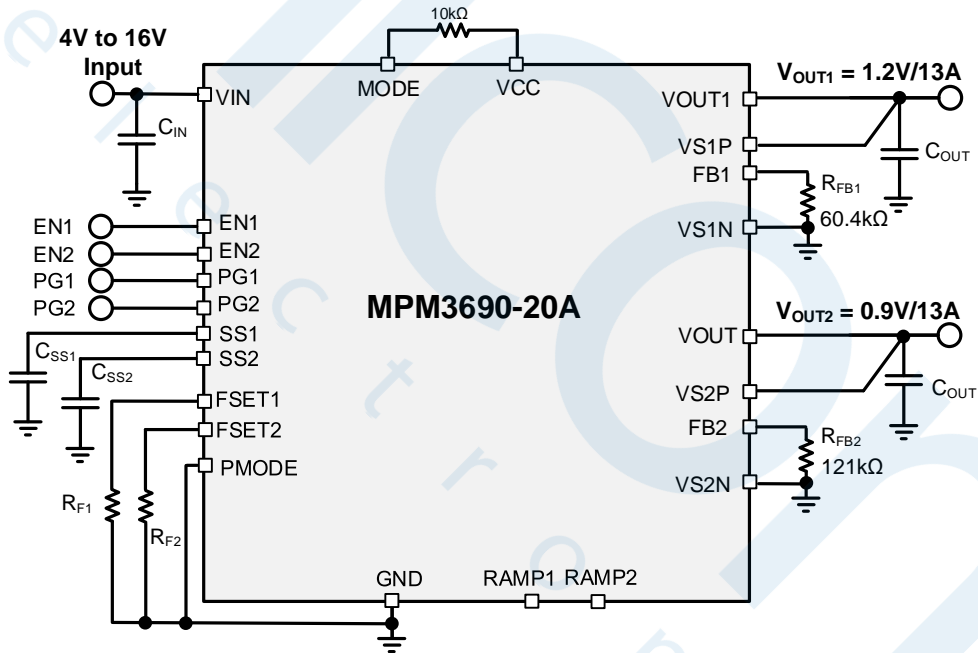

Figure 8: Dual-Output Operation, 1.2V and 0.9V at 13A (Remote Sense Disabled)

TYPICAL APPLICATION CIRCUITS (continued)

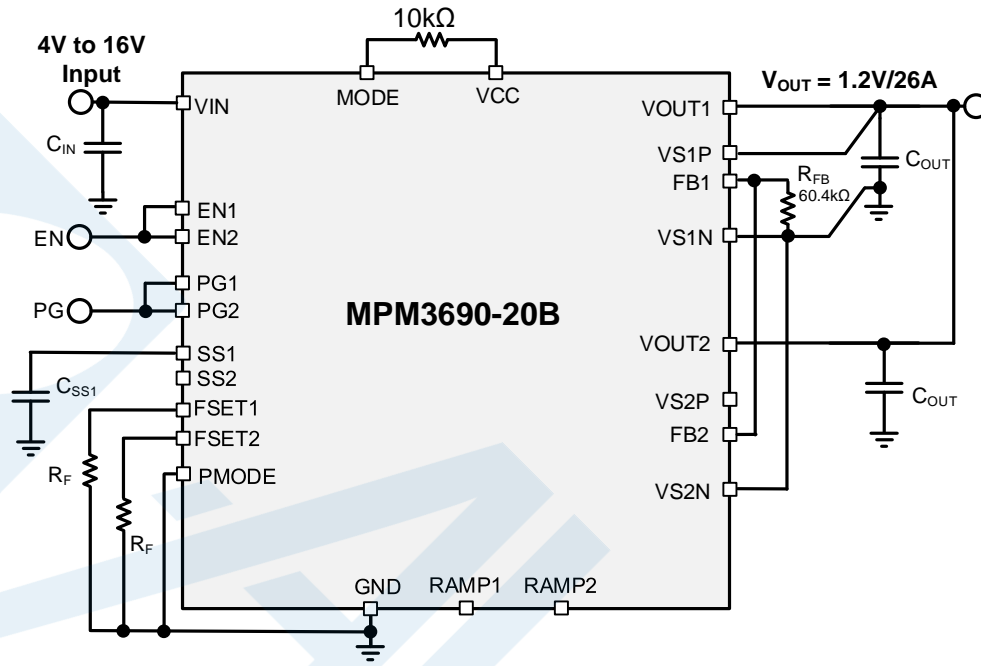

Figure 9: Interleaved Operation, 1.2V at 26A (Remote Sense Enabled)

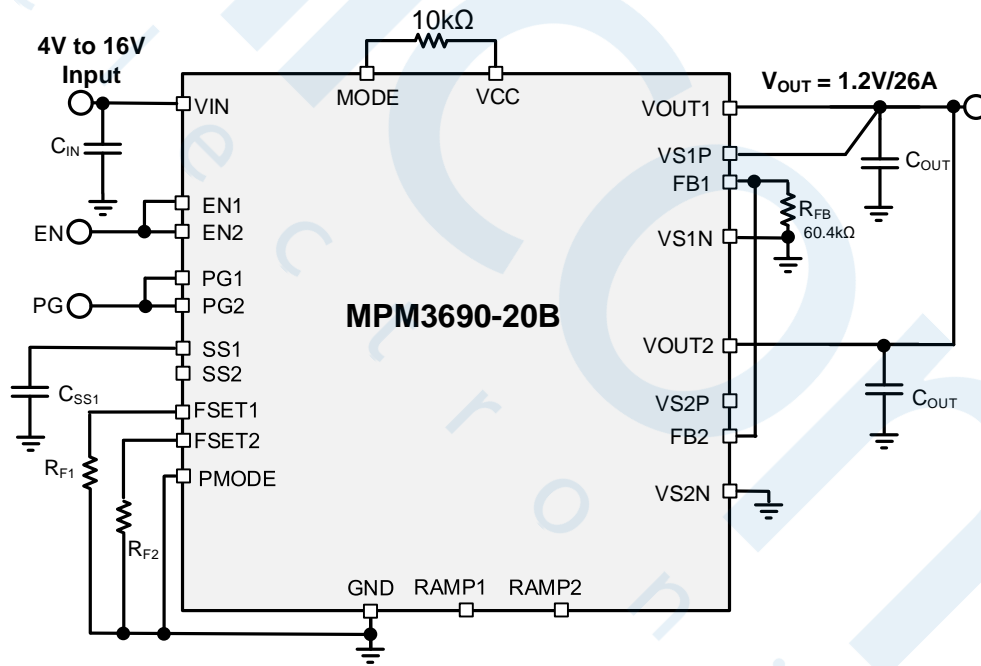
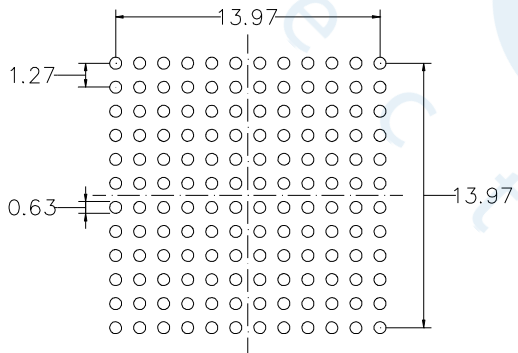
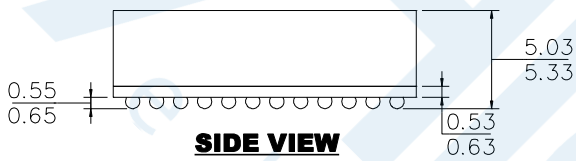
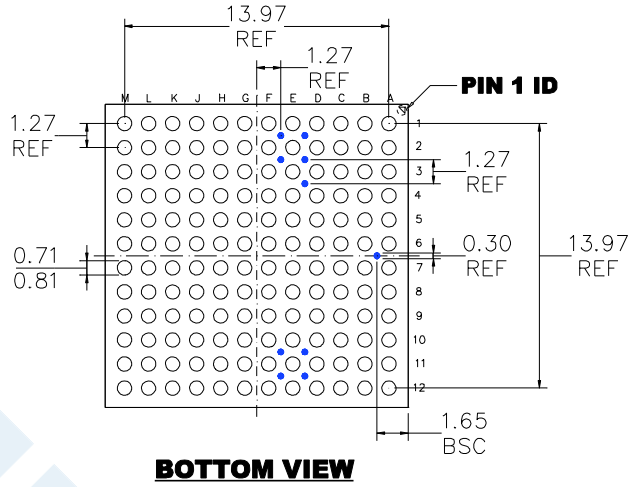
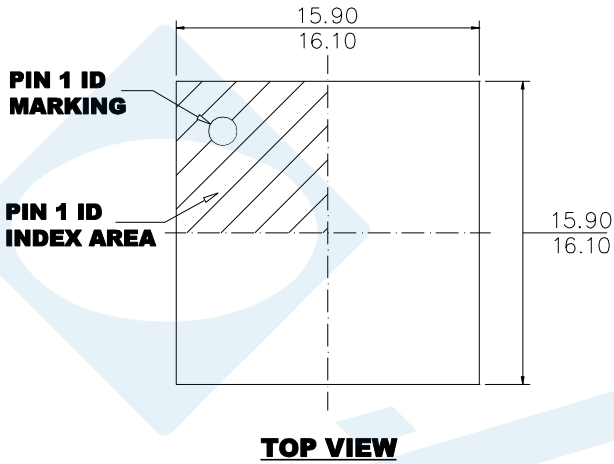

Figure 10: Interleaved Operation, 1.2V at 26A (Remote Sense Disabled)

PACKAGE INFORMATION

BGA (16mmx16mmx5.18mm)



NOTE:

- 1) THE SOLID BLUE CIRCLES REPRESENT TEST PADS WITHOUT SOLDER BALL.
- 2) ALL DIMENSIONS ARE IN MILLIMETERS.
- 3) LEAD COPLANARITY SHALL BE 0.10 MILLIMETERS MAX.
- 4) JEDEC REFERENCE IS MO-275A.
- 5) DRAWING IS NOT TO SCALE.

CARRIER INFORMATION

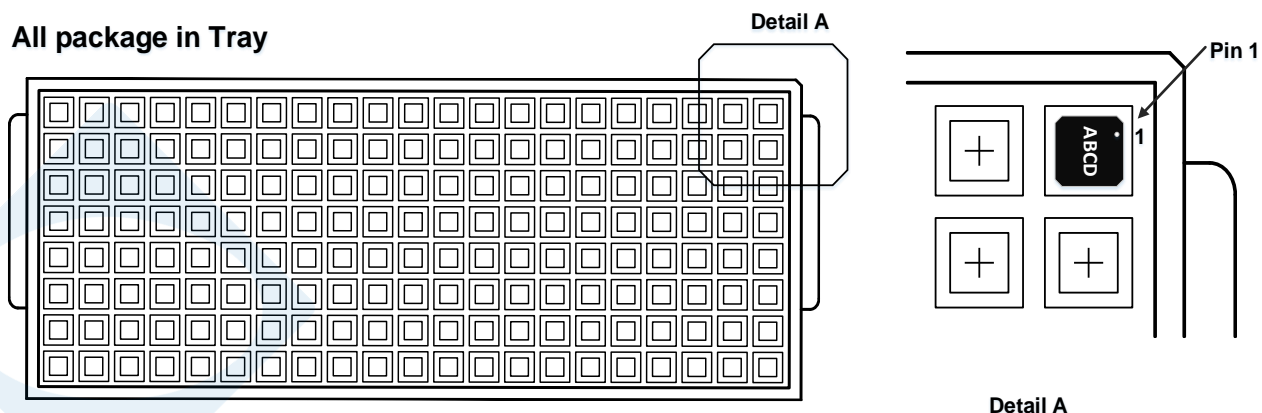
All package in Tray

Note:

6) This is a schematic diagram of the tray. Different packages correspond to different trays with different lengths, widths, and heights

Part Number	Package Description	Quantity/ Tube	Quantity/ Tray	Reel Diameter	Carrier Tape Width	Carrier Tape Pitch
MPM3690GBF-20A	BGA (16mmx16mmx5.18mm)	N/A	90	N/A	N/A	N/A
MPM3690GBF-20B	BGA (16mmx16mmx5.18mm)	N/A	90	N/A	N/A	N/A

REVISION HISTORY

Revision #	Revision Date	Description	Pages Updated
1.0	5/12/2021	Initial Release	-

Notice: The information in this document is subject to change without notice. Please contact MPS for current specifications. Users should warrant and guarantee that third-party Intellectual Property rights are not infringed upon when integrating MPS products into any application. MPS will not assume any legal responsibility for any said applications.