



---

**Charger Flash MCU**

**HT45F5Q-2A**



Singel 3 | B-2550 Kontich | Belgium | Tel. +32 (0)3 458 30 33  
info@alcom.be | www.alcom.be

Rivium 1e straat 52 | 2909 LE Capelle aan den IJssel | The Netherlands  
Tel. +31 (0)10 288 25 00 | info@alcom.nl | www.alcom.nl

Revision: V1.00 Date: December 17, 2021

[www.holtek.com](http://www.holtek.com)

## Table of Contents

<b>Features</b> .....	<b>6</b>
CPU Features .....	6
Peripheral Features.....	6
<b>General Description</b> .....	<b>7</b>
<b>Block Diagram</b> .....	<b>8</b>
<b>Pin Assignment</b> .....	<b>8</b>
<b>Pin Description</b> .....	<b>9</b>
<b>Absolute Maximum Ratings</b> .....	<b>11</b>
<b>D.C. Characteristics</b> .....	<b>11</b>
Operating Voltage Characteristics .....	11
Operating Current Characteristics.....	11
Standby Current Characteristics .....	12
<b>A.C. Characteristics</b> .....	<b>12</b>
High Speed Internal Oscillator – HIRC – Frequency Accuracy .....	12
Low Speed Internal Oscillator Characteristics – LIRC .....	13
Operating Frequency Characteristic Curves .....	13
System Start Up Time Characteristics .....	13
<b>Input/Output Characteristics</b> .....	<b>14</b>
<b>Memory Characteristics</b> .....	<b>14</b>
<b>LVR Electrical Characteristics</b> .....	<b>15</b>
<b>A/D Converter Electrical Characteristics</b> .....	<b>15</b>
<b>D/A Converter Electrical Characteristics</b> .....	<b>15</b>
<b>Operational Amplifier Electrical Characteristics</b> .....	<b>16</b>
<b>Power-on Reset Characteristics</b> .....	<b>16</b>
<b>System Architecture</b> .....	<b>17</b>
Clocking and Pipelining.....	17
Program Counter.....	18
Stack .....	18
Arithmetic and Logic Unit – ALU .....	19
<b>Flash Program Memory</b> .....	<b>20</b>
Structure.....	20
Special Vectors .....	20
Look-up Table.....	20
Table Program Example.....	21
In Circuit Programming – ICP .....	22
On-Chip Debug Support – OCDS .....	23
<b>Data Memory</b> .....	<b>23</b>
Structure.....	23

General Purpose Data Memory .....	24
Special Purpose Data Memory .....	24
<b>Special Function Register Description .....</b>	<b>26</b>
Indirect Addressing Registers – IAR0, IAR1 .....	26
Memory Pointers – MP0, MP1 .....	26
Accumulator – ACC .....	27
Program Counter Low Byte Register – PCL .....	27
Look-up Table Registers – TBLP, TBLH .....	27
Status Register – STATUS .....	27
<b>Emulated EEPROM Data Memory .....</b>	<b>29</b>
Emulated EEPROM Data Memory Structure .....	29
Emulated EEPROM Registers .....	29
Erasing the Emulated EEPROM .....	32
Writing Data to the Emulated EEPROM .....	33
Reading Data from the Emulated EEPROM .....	33
Programming Considerations .....	33
<b>Oscillators .....</b>	<b>35</b>
Oscillator Overview .....	35
System Clock Configurations .....	35
Internal High Speed RC Oscillator – HIRC .....	36
Internal 32kHz Oscillator – LIRC .....	36
<b>Operating Modes and System Clocks .....</b>	<b>37</b>
System Clocks .....	37
System Operation Modes .....	37
Control Registers .....	39
Operating Mode Switching .....	40
Standby Current Considerations .....	43
Wake-up .....	44
<b>Watchdog Timer .....</b>	<b>45</b>
Watchdog Timer Clock Source .....	45
Watchdog Timer Control Register .....	45
Watchdog Timer Operation .....	46
<b>Reset and Initialisation .....</b>	<b>47</b>
Reset Functions .....	47
Reset Initial Conditions .....	49
<b>Input/Output Ports .....</b>	<b>52</b>
Pull-high Resistors .....	52
Port A Wake-up .....	53
I/O Port Control Registers .....	53
Pin-shared Functions .....	53
I/O Pin Structures .....	56
Programming Considerations .....	57

<b>Timer Modules – TM .....</b>	<b>58</b>
Introduction .....	58
TM Operation .....	58
TM Clock Source.....	58
TM Interrupts.....	58
TM External Pins.....	58
Programming Considerations.....	59
<b>Compact Type TM – CTM .....</b>	<b>60</b>
Compact Type TM Operation .....	60
Compact Type TM Register Description.....	61
Compact Type TM Operation Modes .....	65
<b>Analog to Digital Converter .....</b>	<b>71</b>
A/D Converter Overview .....	71
A/D Converter Register Description .....	72
A/D Converter Operation.....	74
A/D Converter Reference Voltage.....	75
A/D Converter Input Signals.....	75
Conversion Rate and Timing Diagram .....	76
Summary of A/D Conversion Steps.....	76
Programming Considerations.....	77
A/D Conversion Function .....	78
A/D Conversion Programming Examples.....	78
<b>Battery Charge Module .....</b>	<b>80</b>
Battery Charge Module Registers .....	80
Digital to Analog Converter .....	81
Operational Amplifiers .....	82
<b>UART Interface.....</b>	<b>83</b>
UART External Pins .....	84
UART Single Wire Mode .....	84
UART Data Transfer Scheme.....	85
UART Status and Control Registers.....	85
Baud Rate Generator .....	91
UART Setup and Control.....	91
UART Transmitter.....	92
UART Receiver .....	94
Managing Receiver Errors .....	95
UART Interrupt Structure.....	96
UART Power Down and Wake-up.....	97
<b>Interrupts .....</b>	<b>98</b>
Interrupt Registers.....	98
Interrupt Operation .....	101
External Interrupt.....	102
Time Base Interrupts .....	102
Multi-function Interrupt .....	104

TM Interrupts .....	104
A/D Converter Interrupt .....	104
UART Interrupt .....	104
Interrupt Wake-up Function .....	105
Programming Considerations .....	105
<b>Application Descriptions .....</b>	<b>106</b>
Introduction .....	106
Functional Description .....	106
Hardware Circuit .....	107
<b>Instruction Set .....</b>	<b>108</b>
Introduction .....	108
Instruction Timing .....	108
Moving and Transferring Data .....	108
Arithmetic Operations .....	108
Logical and Rotate Operation .....	109
Branches and Control Transfer .....	109
Bit Operations .....	109
Table Read Operations .....	109
Other Operations .....	109
<b>Instruction Set Summary .....</b>	<b>110</b>
Table Conventions .....	110
<b>Instruction Definition .....</b>	<b>112</b>
<b>Package Information .....</b>	<b>121</b>
16-pin NSOP (150mil) Outline Dimensions .....	122
20-pin NSOP (150mil) Outline Dimensions .....	123

## Features

### CPU Features

- Operating voltage
  - ◆  $f_{SYS}=8\text{MHz}$ : 2.2V~5.5V
- Up to 0.5 $\mu\text{s}$  instruction cycle with 8MHz system clock at  $V_{DD}=5\text{V}$
- Power down and wake-up functions to reduce power consumption
- Oscillator types:
  - ◆ Internal High Speed 8MHz RC – HIRC
  - ◆ Internal Low Speed 32kHz RC – LIRC
- Multi-mode operation: FAST, SLOW, IDLE and SLEEP
- Fully integrated internal oscillators require no external components
- All instructions executed in one or two instruction cycles
- Table read instructions
- 61 powerful instructions
- 6-level subroutine nesting
- Bit manipulation instruction

### Peripheral Features

- Flash Program Memory: 2K $\times$ 15
- RAM Data Memory: 128 $\times$ 8
- Emulated EEPROM Memory: 32 $\times$ 15
- Watchdog Timer function
- 15 bidirectional I/O lines
- One pin-shared external interrupt
- One Timer Module for time measurement, compare match output or PWM output
- Dual Time Base functions for generation of fixed time interrupt signals
- Fully-duplex/Half-duplex Universal Asynchronous Receiver and Transmitter Interface – UART
- 7 external channel 12-bit resolution A/D converter
- Battery charger circuit
  - ◆ 14-bit D/A Converter and OPA0 are used for constant current control
  - ◆ 12-bit D/A Converter and OPA1 are used for constant voltage control
  - ◆ OPA2 is 20 times amplifier for current sense
- Low voltage reset function
- Package types: 16/20-pin NSOP

## General Description

The HT45F5Q-2A is a Flash Memory A/D type 8-bit high performance RISC architecture microcontroller especially designed for battery charger applications.

For memory features, the Flash Memory offers users the convenience of multi-programming features. Other memory includes an area of RAM Data Memory as well as an area of Emulated EEPROM memory for storage of non-volatile data such as serial numbers, calibration data etc.

Analog feature includes a multi-channel 12-bit A/D converter function. An extremely flexible Timer Module provides timing, pulse generation and PWM generation functions. Communication with the outside world is catered for by including a fully integrated UART interface function, which provides designers with a means of easy communication with external peripheral hardware. Protective features such as an internal Watchdog Timer and Low Voltage Reset coupled with excellent noise immunity and ESD protection ensure that reliable operation is maintained in hostile electrical environments.

A full choice of internal low and high speed oscillators is provided including two fully integrated system oscillators which require no external components for their implementation. The ability to operate and switch dynamically between a range of operating modes using different clock sources gives users the ability to optimise microcontroller operation and minimise power consumption.

For AC/DC charger applications, the device includes a battery charger management module, which can be used for the constant voltage and constant current closed loop charging control. The device therefore reduces the need for the usually required external TL431 component, operational amplifier and resistance analogic D/A Converter in traditional battery charging circuits. Therefore the peripheral circuit is more reduced, resulting in a smaller PCB area.

The charger management module is composed of two parts. The first part contains two groups of OPAs and D/A Converters, which are used to control the charging voltage and current. The upper limit value of the charger constant current and constant voltage can be obtained by configuring the D/A Converters in the software. The 14-bit D/A Converter is used for constant current control while the 12-bit D/A Converter is used for constant voltage control. The second part of the charger management contains a fixed gain operational amplifier which is used for current amplification. This improves the current resolution and allows the use of smaller current detection resistors thus reducing the resistor power consumption.

The D/A Converter in the charger management module is not only used for setting charging voltage and current, but also can be used together with the specific charger production fixtures for improving the traditional manual calibration techniques. By using the external production fixtures, the charger current voltage/current conditions can be confirmed. If the margin of errors is exceeded, the MCU will correct the error by fine tuning the D/A Converter, and store the corrected parameters to Emulated EEPROM. When the charger is recharged, the D/A Converter will be given a new correction value to implement correction purpose. Refer to the Holtek application notes for more details.

The inclusion of flexible I/O programming features, Time Base functions along with many other features, further enhance device functionality and flexibility for wide range of application possibilities.

### Block Diagram

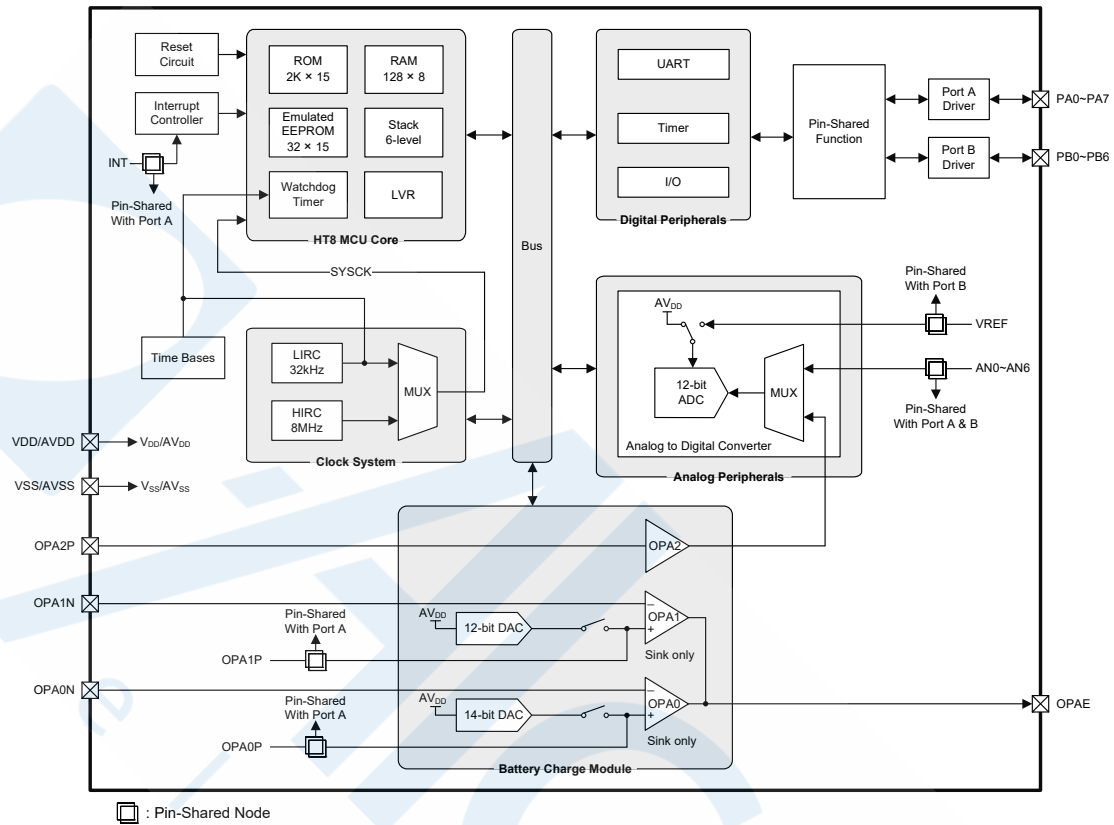

### Pin Assignment

VDD/AVDD	1	16	VSS/AVSS
PA5/OPA0P/RX/TX	2	15	PB1/AN1/VREF
PA6/OPA1P/TX	3	14	PB2/AN2
PB0/AN0	4	13	PA7/CTP/TX
OPA1N	5	12	PA4/CTPB
OPAE	6	11	PA3/INT
OPA0N	7	10	PA2/OCDSCK/ICPCK/RX/TX
PA1/OPA2P/AN6	8	9	PA0/OCSDA/ICPDA/TX

**HT45F5Q-2A/HT45V5Q-2A**  
**16 NSOP-A**



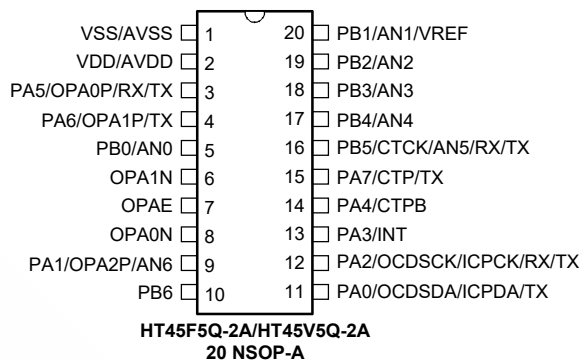

- Note: 1. If the pin-shared pin functions have multiple outputs, the desired pin-shared function is determined by the corresponding software control bits.
2. The OCSDA and OCDSCK pins are supplied as the OCDS dedicated pins and as such only available for the HT45V5Q-2A device which is the OCDS EV chip for the HT45F5Q-2A device.
3. For the less pin-count package type there will be unbounded pins which should be properly configured to avoid unwanted power consumption resulting from floating input conditions. Refer to the “Standby Current Considerations” and “Input/Output Ports” sections.

## Pin Description

The function of each pin is listed in the following table, however the details behind how each pin is configured is contained in other sections of the datasheet. As the Pin Description table shows the situation for the package with the most pins, not all pins in the table will be available on smaller package sizes.

Pin Name	Function	OPT	I/T	O/T	Description
PA0/OCSDA/ ICPDA/TX	PA0	PAPU PAWU PAS0	ST	CMOS	General purpose I/O. Register enabled pull-up and wake-up
	OCSDA	—	ST	CMOS	OCDS address/data, for EV chip only
	ICPDA	—	ST	CMOS	ICP address/data
	TX	PAS0	—	CMOS	UART serial data output
PA1/OPA2P/AN6	PA1	PAPU PAWU PAS0	ST	CMOS	General purpose I/O. Register enabled pull-up and wake-up
	OPA2P	PAS0	AN	—	Operational amplifier 2 positive input
	AN6	PAS0	AN	—	A/D Converter external input 6
PA2/OCDSCK/ ICPCK/RX/TX	PA2	PAPU PAWU PAS0	ST	CMOS	General purpose I/O. Register enabled pull-up and wake-up
	OCDSCK	—	ST	—	OCDS clock, for EV chip only
	ICPCK	—	ST	—	ICP clock
	RX/TX	PAS0 IFS	ST	CMOS	UART serial data input in full-duplex communication or UART serial data input/output in single wire mode communication
PA3/INT	PA3	PAPU PAWU	ST	CMOS	General purpose I/O. Register enabled pull-up and wake-up
	INT	INTEG INTC0	ST	—	External interrupt input

Pin Name	Function	OPT	I/T	O/T	Description
PA4/CTPB	PA4	PAPU PAWU PAS1	ST	CMOS	General purpose I/O. Register enabled pull-up and wake-up
	CTPB	PAS1	—	CMOS	CTM inverted output
PA5/OPA0P/ RX/TX	PA5	PAPU PAWU PAS1	ST	CMOS	General purpose I/O. Register enabled pull-up and wake-up
	OPA0P	PAS1	AN	—	Operational amplifier 0 positive input
	RX/TX	PAS1 IFS	ST	CMOS	UART serial data input in full-duplex communication or UART serial data input/output in single wire mode communication
PA6/OPA1P/TX	PA6	PAPU PAWU PAS1	ST	CMOS	General purpose I/O. Register enabled pull-up and wake-up
	OPA1P	PAS1	AN	—	Operational amplifier 1 positive input
	TX	PAS1	—	CMOS	UART serial data output
PA7/CTP/TX	PA7	PAPU PAWU PAS1	ST	CMOS	General purpose I/O. Register enabled pull-up and wake-up
	CTP	PAS1	—	CMOS	CTM output
	TX	PAS1	—	CMOS	UART serial data output
PB0/AN0	PB0	PBPU PBS0	ST	CMOS	General purpose I/O. Register enabled pull-up
	AN0	PBS0	AN	—	A/D Converter external input 0
PB1/AN1/VREF	PB1	PBPU PBS0	ST	CMOS	General purpose I/O. Register enabled pull-up
	AN1	PBS0	AN	—	A/D Converter external input 1
	VREF	PBS0	AN	—	A/D Converter external reference voltage input
PB2/AN2	PB2	PBPU PBS0	ST	CMOS	General purpose I/O. Register enabled pull-up
	AN2	PBS0	AN	—	A/D Converter external input 2
PB3/AN3	PB3	PBPU PBS0	ST	CMOS	General purpose I/O. Register enabled pull-up
	AN3	PBS0	AN	—	A/D Converter external input 3
PB4/AN4	PB4	PBPU PBS1	ST	CMOS	General purpose I/O. Register enabled pull-up
	AN4	PBS1	AN	—	A/D Converter external input 4
PB5/CTCK/AN5/ RX/TX	PB5	PBPU PBS1	ST	CMOS	General purpose I/O. Register enabled pull-up
	CTCK	PBS1	ST	—	CTM clock input
	AN5	PBS1	AN	—	A/D Converter external input 5
	RX/TX	PBS1 IFS	ST	CMOS	UART serial data input in full-duplex communication or UART serial data input/output in single wire mode communication
PB6	PB6	PBPU	ST	CMOS	General purpose I/O. Register enabled pull-up
OPA0N	OPA0N	—	AN	—	Operational amplifier 0 negative input
OPA1N	OPA1N	—	AN	—	Operational amplifier 1 negative input
OPAE	OPAE	—	—	AN	Operational amplifier output
VDD/AVDD	VDD	—	PWR	—	Digital positive power supply
	AVDD	—	PWR	—	Analog positive power supply

Pin Name	Function	OPT	I/T	O/T	Description
VSS/AVSS	VSS	—	PWR	—	Digital negative power supply, ground
	AVSS	—	PWR	—	Analog negative power supply, ground

Legend: I/T: Input type; O/T: Output type;  
OPT: Optional by register option; PWR: Power;  
ST: Schmitt Trigger input; CMOS: CMOS output;  
AN: Analog signal

## Absolute Maximum Ratings

Supply Voltage .....	V <sub>SS</sub> -0.3V to 6.0V
Input Voltage .....	V <sub>SS</sub> -0.3V to V <sub>DD</sub> +0.3V
Storage Temperature.....	-50°C to 125°C
Operating Temperature.....	-40°C to 85°C
I <sub>OH</sub> Total .....	-80mA
I <sub>OL</sub> Total .....	80mA
Total Power Dissipation .....	500mW

Note: These are stress ratings only. Stresses exceeding the range specified under “Absolute Maximum Ratings” may cause substantial damage to the device. Functional operation of the device at other conditions beyond those listed in the specification is not implied and prolonged exposure to extreme conditions may affect device reliability.

## D.C. Characteristics

For data in the following tables, note that factors such as oscillator type, operating voltage, operating frequency, pin load conditions, temperature and program instruction type, etc., can all exert an influence on the measured values.

### Operating Voltage Characteristics

T<sub>a</sub>=-40°C~85°C

Symbol	Parameter	Test Conditions	Min.	Typ.	Max.	Unit
V <sub>DD</sub>	Operating Voltage – HIRC	f <sub>sys</sub> =8MHz	2.2	—	5.5	V
	Operating Voltage – LIRC	f <sub>sys</sub> =32kHz	2.2	—	5.5	V

### Operating Current Characteristics

T<sub>a</sub>=-40°C~85°C

Symbol	Operating Mode	Test Conditions		Min.	Typ.	Max.	Unit
		V <sub>DD</sub>	Conditions				
I <sub>DD</sub>	SLOW Mode – LIRC	2.2V	f <sub>sys</sub> =32kHz, OPA0/1 enable	—	230	300	μA
		3V		—	310	820	
		5V		—	630	1250	
	FAST Mode – HIRC	2.2V	f <sub>sys</sub> =8MHz, OPA0/1 enable	—	0.6	0.8	mA
		3V		—	1.1	2.0	
		5V		—	2.2	3.6	

Note: When using the characteristic table data, the following notes should be taken into consideration:

1. Any digital inputs are setup in a non-floating condition.

2. All measurements are taken under conditions of no load and with all peripherals in an off state.
3. There are no DC current paths.
4. All Operating Current values are measured using a continuous NOP instruction program loop.

### Standby Current Characteristics

Ta=25°C, unless otherwise specified

Symbol	Standby Mode	Test Conditions		Min.	Typ.	Max.	Max. @85°C	Unit
		V <sub>DD</sub>	Conditions					
I <sub>STB</sub>	SLEEP Mode	2.2V	WDT off, OPA0/1 enable	—	TBD	TBD	TBD	μA
		3V		—	300	800	810	
		5V		—	600	1200	1210	
		2.2V	WDT on, OPA0/1 enable	—	TBD	TBD	TBD	
		3V		—	300	800	810	
		5V		—	600	1200	1210	
	IDLE0 Mode – LIRC	2.2V	f <sub>SUB</sub> on, OPA0/1 enable	—	TBD	TBD	TBD	
		3V		—	300	800	810	
		5V		—	600	1200	1210	
	IDLE1 Mode – HIRC	2.2V	f <sub>SUB</sub> on, f <sub>SYS</sub> =8MHz, OPA0/1 enable	—	588	700	740	
		3V		—	660	1100	1200	
		5V		—	1200	2000	2160	

Note: When using the characteristic table data, the following notes should be taken into consideration:

1. Any digital inputs are setup in a non-floating condition.
2. All measurements are taken under conditions of no load and with all peripherals in an off state.
3. There are no DC current paths.
4. All Standby Current values are taken after a HALT instruction execution thus stopping all instruction execution.

### A.C. Characteristics

For data in the following tables, note that factors such as oscillator type, operating voltage, operating frequency and temperature etc., can all exert an influence on the measured values.

#### High Speed Internal Oscillator – HIRC – Frequency Accuracy

During the program writing operation the writer will trim the HIRC oscillator at a user selected HIRC frequency and user selected voltage of either 3V or 5V.

Symbol	Parameter	Test Conditions		Min.	Typ.	Max.	Unit
		V <sub>DD</sub>	Temp.				
f <sub>HIRC</sub>	8MHz Writer Trimmed HIRC Frequency	3V/5V	25°C	-1%	8	+1%	MHz
			-40°C~85°C	-2%	8	+2%	
		2.2V~5.5V	25°C	-2.5%	8	+2.5%	
			-40°C~85°C	-3%	8	+3%	

- Note: 1. The 3V/5V values for V<sub>DD</sub> are provided as these are the two selectable fixed voltages at which the HIRC frequency is trimmed by the writer.
2. The row below the 3V/5V trim voltage row is provided to show the values for the full V<sub>DD</sub> range operating voltage. It is recommended that the trim voltage is fixed at 3V for application voltage ranges from 2.2V to 3.6V and fixed at 5V for application voltage ranges from 3.3V to 5.5V.

### Low Speed Internal Oscillator Characteristics – LIRC

Symbol	Parameter	Test Conditions		Min.	Typ.	Max.	Unit
		V <sub>DD</sub>	Temp.				
f <sub>LIRC</sub>	LIRC Frequency	5V	25°C	25.6	32	38.4	kHz
		2.2V~5.5V	25°C	12.8	32	41.6	
			-40°C~85°C	8	32	60	
t <sub>START</sub>	LIRC Start Up Time	—	25°C	—	—	100	μs

### Operating Frequency Characteristic Curves

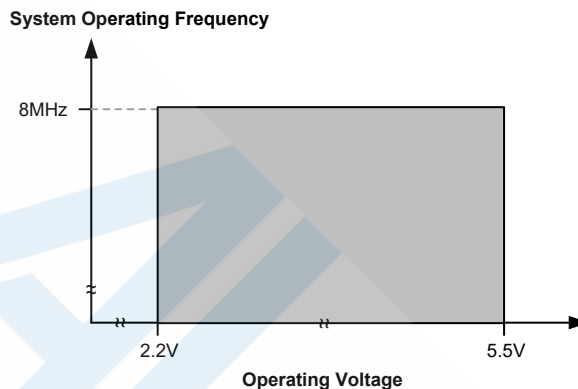

### System Start Up Time Characteristics

T<sub>a</sub>=-40°C~85°C

Symbol	Parameter	Test Conditions		Min.	Typ.	Max.	Unit
		V <sub>DD</sub>	Conditions				
t <sub>SST</sub>	System Start-up Time (Wake-up from Condition where f <sub>sys</sub> is off)	—	f <sub>sys</sub> =f <sub>H</sub> ~f <sub>H</sub> /64, f <sub>H</sub> =f <sub>HIRC</sub>	—	16	—	t <sub>HIRC</sub>
		—	f <sub>sys</sub> =f <sub>SUB</sub> =f <sub>LIRC</sub>	—	2	—	t <sub>LIRC</sub>
	System Start-up Time (Wake-up from Condition where f <sub>sys</sub> is on)	—	f <sub>sys</sub> =f <sub>H</sub> ~f <sub>H</sub> /64, f <sub>H</sub> =f <sub>HIRC</sub>	—	2	—	t <sub>H</sub>
		—	f <sub>sys</sub> =f <sub>SUB</sub> =f <sub>LIRC</sub>	—	2	—	t <sub>SUB</sub>
	System Speed Switch Time (FAST to SLOW Mode or SLOW to FAST Mode)	—	f <sub>HIRC</sub> switches from off → on	—	16	—	t <sub>HIRC</sub>
t <sub>RSTD</sub>	System Reset Delay Time (Reset source from Power-on Reset or LVR Hardware Reset)	—	RR <sub>POR</sub> =5V/ms	8.3	16.7	50.0	ms
	System Reset Delay Time (LVR/WDT Software Reset)	—	—	8.3	16.7	50.0	ms
	System Reset Delay Time (Reset source from WDT Overflow)	—	—	8.3	16.7	50.0	ms
t <sub>SRESET</sub>	Minimum Software Reset Width to Reset	—	—	45	90	375	μs

- Note: 1. For the System Start-up time values, whether f<sub>sys</sub> is on or off depends upon the mode type and the chosen f<sub>sys</sub> system oscillator. Details are provided in the System Operating Modes section.
2. The time units, shown by the symbol t<sub>HIRC</sub> etc. are the inverse of the corresponding frequency values as provided in the frequency tables. For example t<sub>HIRC</sub>=1/f<sub>HIRC</sub>, t<sub>SYS</sub>=1/f<sub>SYS</sub> etc.
3. If the LIRC is used as the system clock and if it is off when in the SLEEP Mode, then an additional LIRC start up time, t<sub>START</sub>, as provided in the LIRC frequency table, must be added to the t<sub>SST</sub> time in the table above.
4. The System Speed Switch Time is effectively the time taken for the newly activated oscillator to start up.

## Input/Output Characteristics

 $T_a = -40^{\circ}\text{C} \sim 85^{\circ}\text{C}$ 

Symbol	Parameter	Test Conditions		Min.	Typ.	Max.	Unit
		V <sub>DD</sub>	Conditions				
V <sub>IL</sub>	Input Low Voltage for I/O Ports or Input Pins	5V	—	0	—	1.5	V
		—	—	0	—	0.2V <sub>DD</sub>	
V <sub>IH</sub>	Input High Voltage for I/O Ports or Input Pins	5V	—	3.5	—	5.0	V
		—	—	0.8V <sub>DD</sub>	—	V <sub>DD</sub>	
I <sub>OL</sub>	Sink Current for I/O Ports	3V	V <sub>OL</sub> =0.1V <sub>DD</sub>	16	32	—	mA
		5V		32	65	—	
I <sub>OH</sub>	Source Current for I/O Ports	3V	V <sub>OH</sub> =0.9V <sub>DD</sub>	-4	-8	—	mA
		5V		-8	-16	—	
R <sub>PH</sub>	Pull-high Resistance for I/O Ports <sup>(Note)</sup>	3V	—	20	60	100	kΩ
		5V	—	10	30	50	
I <sub>LEAK</sub>	Input Leakage Current	5V	V <sub>IN</sub> =V <sub>DD</sub> or V <sub>IN</sub> =V <sub>SS</sub>	—	—	±1	μA
t <sub>TCK</sub>	TM Clock Input Minimum Pulse Width	—	—	0.3	—	—	μs
t <sub>INT</sub>	External Interrupt Input Minimum Pulse Width	—	—	0.3	—	—	μs

Note: The R<sub>PH</sub> internal pull-high resistance value is calculated by connecting to ground and enabling the input pin with a pull-high resistor and then measuring the pin current at the specified supply voltage level. Dividing the voltage by this measured current provides the R<sub>PH</sub> value.

## Memory Characteristics

 $T_a = -40^{\circ}\text{C} \sim 85^{\circ}\text{C}$ , unless otherwise specified

Symbol	Parameter	Test Conditions		Min.	Typ.	Max.	Unit
		V <sub>DD</sub>	Conditions				
<b>Flash Program</b>							
V <sub>DD</sub>	Operating Voltage for Read	—	—	2.2	—	5.5	V
	Operating Voltage for Write	—	—	3.0	—	5.5	
t <sub>DEW</sub>	Erase/Write Time	—	—	—	2	3	ms
I <sub>DDPGM</sub>	Programming/Erase Current on V <sub>DD</sub>	—	—	—	—	5.0	mA
E <sub>P</sub>	Cell Endurance	—	—	10K	—	—	E/W
t <sub>RETD</sub>	ROM Data Retention Time	—	T <sub>a</sub> =25°C	—	40	—	Year
<b>Emulated EEPROM Memory</b>							
V <sub>DD</sub>	Operating Voltage for Read	—	—	2.2	—	5.5	V
	Operating Voltage for Erase/Write	—	—	2.2	—	5.5	
t <sub>EW</sub>	Erase/Write Cycle Time	—	EWRTS[1:0]=00B	—	2	3	ms
		—	EWRTS[1:0]=01B	—	4	6	
		—	EWRTS[1:0]=10B	—	8	12	
		—	EWRTS[1:0]=11B	—	16	24	
E <sub>P</sub>	Cell Endurance	—	—	10K	—	—	E/W
t <sub>RETD</sub>	Data Retention Time	—	T <sub>a</sub> =25°C	—	40	—	Year
<b>RAM Data Memory</b>							
V <sub>DR</sub>	RAM Data Retention Voltage	—	—	2.2	—	—	V

Note: 1. “E/W” means Erase/Write times.

2. The Emulated EEPROM erase/write operation can only be executed when the f<sub>sys</sub> clock frequency is equal to or greater than 2MHz.

## LVR Electrical Characteristics

Ta=-40°C~85°C

Symbol	Parameter	Test Conditions		Min.	Typ.	Max.	Unit
		V <sub>DD</sub>	Conditions				
V <sub>LVR</sub>	Low Voltage Reset Voltage	—	LVR enable	-5%	2.1	+5%	V
t <sub>LVR</sub>	Minimum Low Voltage Width to Reset	—	TLVR[1:0]=00B	120	240	480	μs
			TLVR[1:0]=01B	0.5	1	2	
			TLVR[1:0]=10B	1	2	4	
			TLVR[1:0]=11B	2	4	8	
I <sub>LVR</sub>	Additional Current for LVR Enable	3V	LVR enable, V <sub>LVR</sub> =2.1V	—	—	15	μA
		5V		—	15	25	

## A/D Converter Electrical Characteristics

Ta=-40°C~85°C

Symbol	Parameter	Test Conditions		Min.	Typ.	Max.	Unit
		V <sub>DD</sub>	Conditions				
AV <sub>DD</sub>	A/D Converter Operating Voltage	—	—	2.2	—	5.5	V
V <sub>ADI</sub>	A/D Converter Input Voltage	—	—	0	—	V <sub>REF</sub>	V
V <sub>REF</sub>	A/D Converter Reference Voltage	—	—	2	—	AV <sub>DD</sub>	V
N <sub>R</sub>	A/D Converter Resolution	—	—	—	—	12	Bit
DNL	A/D Converter Differential Non-linearity	—	V <sub>REF</sub> =AV <sub>DD</sub> , t <sub>ADCK</sub> =0.5μs	-3	—	3	LSB
INL	A/D Converter Integral Non-linearity	—	V <sub>REF</sub> =AV <sub>DD</sub> , t <sub>ADCK</sub> =0.5μs	-4	—	4	LSB
I <sub>ADC</sub>	Additional Current for A/D Converter Enable	2.2V	No load, t <sub>ADCK</sub> =0.5μs	—	300	420	μA
		3V		—	340	500	
		5V		—	500	700	
t <sub>ADCK</sub>	A/D Converter Clock Period	—	—	0.5	—	10.0	μs
t <sub>ON2ST</sub>	A/D Converter On-to-Start Time	—	—	4	—	—	μs
t <sub>ADS</sub>	A/D Sampling Time	—	—	—	4	—	t <sub>ADCK</sub>
t <sub>ADC</sub>	A/D Conversion Time (Including A/D Sample and Hold Time)	—	—	—	16	—	t <sub>ADCK</sub>
GERR	A/D Conversion Gain Error	—	V <sub>REF</sub> =AV <sub>DD</sub>	-4	—	4	LSB
OSRR	A/D Conversion Offset Error	—	V <sub>REF</sub> =AV <sub>DD</sub>	-4	—	4	LSB

## D/A Converter Electrical Characteristics

Ta=-40°C~85°C

Symbol	Parameter	Test Conditions		Min.	Typ.	Max.	Unit
		V <sub>DD</sub>	Conditions				
AV <sub>DD</sub>	D/A Converter Operating Voltage	—	—	2.2	—	5.5	V
V <sub>DACO</sub>	D/A Converter Output Voltage Range	—	—	AV <sub>SS</sub>	—	AV <sub>DD</sub>	V
I <sub>DAC</sub>	Additional Current for D/A Converter 0 Enable	5V	—	—	600	800	μA
	Additional Current for D/A Converter 1 Enable	5V	—	—	500	600	
t <sub>ST</sub>	D/A Converter Settling Time	5V	C <sub>LOAD</sub> =50pF	—	—	5	μs
DNL	D/A Converter 0 Differential Non-linearity	5V	V <sub>REF</sub> =AV <sub>DD</sub>	—	±6	±12	LSB
	D/A Converter 1 Differential Non-linearity			—	±4	±10	



Symbol	Parameter	Test Conditions		Min.	Typ.	Max.	Unit
		V <sub>DD</sub>	Conditions				
INL	D/A Converter 0 Integral Non-linearity	5V	V <sub>REF</sub> =AV <sub>DD</sub>	—	±8	±16	LSB
	D/A Converter 1 Integral Non-linearity			—	±6	±12	
Ro	D/A Converter 0/1 R2R Output Resistor	5V	—	—	13	—	kΩ

## Operational Amplifier Electrical Characteristics

T<sub>a</sub>=-40°C~85°C, unless otherwise specified

Symbol	Parameter	Test Conditions		Min.	Typ.	Max.	Unit
		V <sub>DD</sub>	Conditions				
I <sub>OPA</sub>	Additional Current for Each OPA	5V	No load	—	300	600	μA
V <sub>OS</sub>	Input Offset Voltage	5V	OPA0/1 without calibration T <sub>a</sub> =25°C	-7	5	7	mV
		5V	OPA2 without calibration (OOF[5:0]=100000B)	-15	—	15	mV
		5V	OPA2 with calibration	-2	—	2	mV
V <sub>CM</sub>	Common Mode Voltage Range	5V	—	AV <sub>SS</sub>	—	AV <sub>DD</sub> -1.4	V
I <sub>SINK</sub>	Output Sink Current	3V	V <sub>OL</sub> =0.3V	0.7	1.2	—	mA
		5V	V <sub>OL</sub> =0.5V	1.6	2.8	—	mA
Ga	OPA2 PGA Gain Accuracy	3V	Relative gain	-5	—	5	%
		5V		-5	—	5	%
I <sub>PGA</sub>	OPA2 PGA Current Consumption	5V	Gain=20	—	320	630	μA

## Power-on Reset Characteristics

T<sub>a</sub>=-40°C~85°C

Symbol	Parameter	Test Conditions		Min.	Typ.	Max.	Unit
		V <sub>DD</sub>	Conditions				
V <sub>POR</sub>	V <sub>DD</sub> Start Voltage to Ensure Power-on Reset	—	—	—	—	100	mV
RR <sub>POR</sub>	V <sub>DD</sub> Rising Rate to Ensure Power-on Reset	—	—	0.035	—	—	V/ms
t <sub>POR</sub>	Minimum Time for V <sub>DD</sub> Stays at V <sub>POR</sub> to Ensure Power-on Reset	—	—	1	—	—	ms

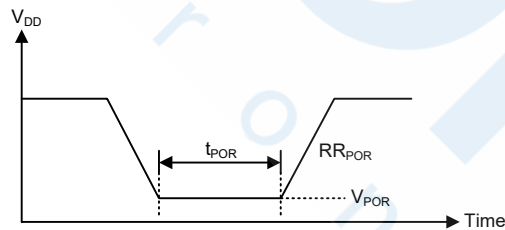



## System Architecture

A key factor in the high-performance features of the Holtek range of microcontrollers is attributed to their internal system architecture. The device takes advantage of the usual features found within RISC microcontrollers providing increased speed of operation and enhanced performance. The pipelining scheme is implemented in such a way that instruction fetching and instruction execution are overlapped, hence instructions are effectively executed in one cycle, with the exception of branch or call instructions which need one more cycle. An 8-bit wide ALU is used in practically all instruction set operations, which carries out arithmetic operations, logic operations, rotation, increment, decrement, branch decisions, etc. The internal data path is simplified by moving data through the Accumulator and the ALU. Certain internal registers are implemented in the Data Memory and can be directly or indirectly addressed. The simple addressing methods of these registers along with additional architectural features ensure that a minimum of external components is required to provide a functional I/O and A/D control system with maximum reliability and flexibility. This makes the device suitable for low-cost, high-volume production for controller applications.

### Clocking and Pipelining

The main system clock, derived from either an HIRC or LIRC oscillator is subdivided into four internally generated non-overlapping clocks, T1~T4. The Program Counter is incremented at the beginning of the T1 clock during which time a new instruction is fetched. The remaining T2~T4 clocks carry out the decoding and execution functions. In this way, one T1~T4 clock cycle forms one instruction cycle. Although the fetching and execution of instructions takes place in consecutive instruction cycles, the pipelining structure of the microcontroller ensures that instructions are effectively executed in one instruction cycle. The exception to this are instructions where the contents of the Program Counter are changed, such as subroutine calls or jumps, in which case the instruction will take one more instruction cycle to execute.

For instructions involving branches, such as jump or call instructions, two machine cycles are required to complete instruction execution. An extra cycle is required as the program takes one cycle to first obtain the actual jump or call address and then another cycle to actually execute the branch. The requirement for this extra cycle should be taken into account by programmers in timing sensitive applications.

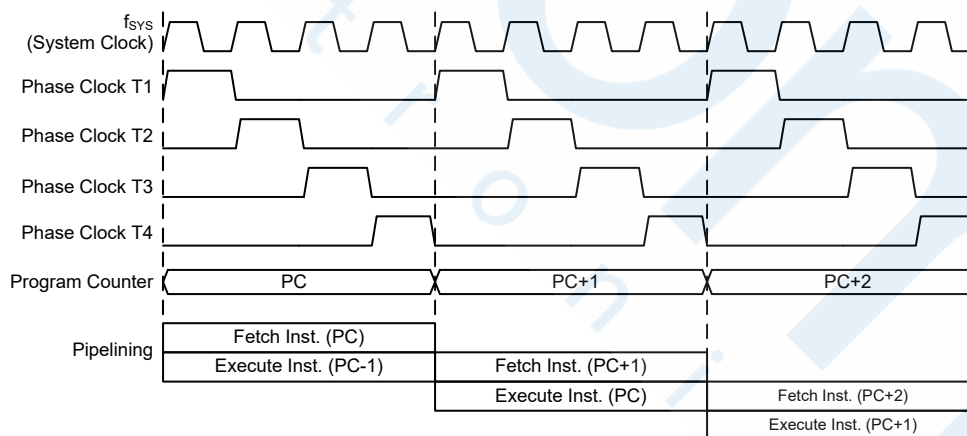

**System Clocking and Pipelining**

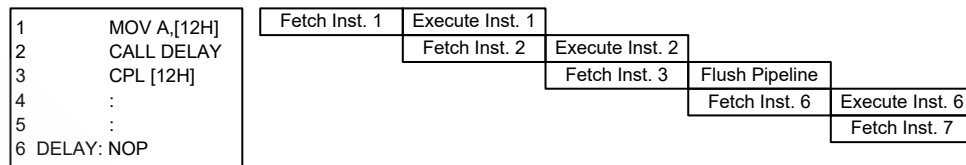

**Instruction Fetching**

### Program Counter

During program execution, the Program Counter is used to keep track of the address of the next instruction to be executed. It is automatically incremented by one each time an instruction is executed except for instructions, such as “JMP” or “CALL” that demand a jump to a non-consecutive Program Memory address. Only the lower 8 bits, known as the Program Counter Low Register, are directly addressable by the application program.

When executing instructions requiring jumps to non-consecutive addresses such as a jump instruction, a subroutine call, interrupt or reset, etc., the microcontroller manages program control by loading the required address into the Program Counter. For conditional skip instructions, once the condition has been met, the next instruction, which has already been fetched during the present instruction execution, is discarded and a dummy cycle takes its place while the correct instruction is obtained.

Program Counter	
Program Counter High Byte	PCL Register
PC10~PC8	PCL7~PCL0

### Program Counter

The lower byte of the Program Counter, known as the Program Counter Low Byte register or PCL, is available for program control and is a readable and writeable register. By transferring data directly into this register, a short program jump can be executed directly; however, as only this low byte is available for manipulation, the jumps are limited to the present page of memory that is 256 locations. When such program jumps are executed it should also be noted that a dummy cycle will be inserted. Manipulating the PCL register may cause program branching, so an extra cycle is needed to pre-fetch.

### Stack

This is a special part of the memory which is used to save the contents of the Program Counter only. The stack is organized into 6 levels and neither part of the data nor part of the program space, and is neither readable nor writeable. The activated level is indexed by the Stack Pointer, and is neither readable nor writeable. At a subroutine call or interrupt acknowledge signal, the contents of the Program Counter are pushed onto the stack. At the end of a subroutine or an interrupt routine, signaled by a return instruction, RET or RETI, the Program Counter is restored to its previous value from the stack. After a device reset, the Stack Pointer will point to the top of the stack.

If the stack is full and an enabled interrupt takes place, the interrupt request flag will be recorded but the acknowledge signal will be inhibited. When the Stack Pointer is decremented, by RET or RETI, the interrupt will be serviced. This feature prevents stack overflow allowing the programmer to use the structure more easily. However, when the stack is full, a CALL subroutine instruction can still be executed which will result in a stack overflow. Precautions should be taken to avoid such cases which might cause unpredictable program branching.

If the stack is overflow, the first Program Counter save in the stack will be lost.

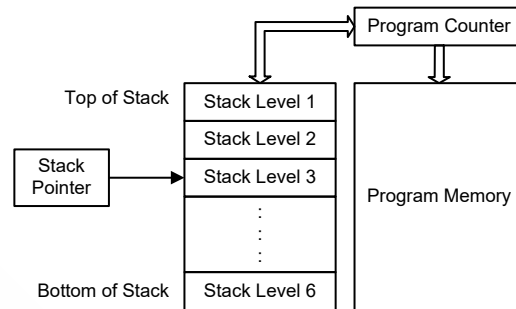

### Arithmetic and Logic Unit – ALU

The arithmetic-logic unit or ALU is a critical area of the microcontroller that carries out arithmetic and logic operations of the instruction set. Connected to the main microcontroller data bus, the ALU receives related instruction codes and performs the required arithmetic or logical operations after which the result will be placed in the specified register. As these ALU calculation or operations may result in carry, borrow or other status changes, the status register will be correspondingly updated to reflect these changes. The ALU supports the following functions:

- Arithmetic operations:  
ADD, ADDM, ADC, ADCM, SUB, SUBM, SBC, SBCM, DAA
- Logic operations:  
AND, OR, XOR, ANDM, ORM, XORM, CPL, CPLA
- Rotation:  
RRA, RR, RRCA, RRC, RLA, RL, RLCA, RLC
- Increment and Decrement:  
INCA, INC, DECA, DEC
- Branch decision:  
JMP, SZ, SZA, SNZ, SIZ, SDZ, SIZA, SDZA, CALL, RET, RETI

## Flash Program Memory

The Program Memory is the location where the user code or program is stored. For the device the Program Memory is Flash type, which means it can be programmed and re-programmed a large number of times, allowing the user the convenience of code modification on the same device. By using the appropriate programming tools, the Flash device offers users the flexibility to conveniently debug and develop their applications while also offering a means of field programming and updating.

### Structure

The Program Memory has a capacity of 2K×15 bits. The Program Memory is addressed by the Program Counter and also contains data, table information and interrupt entries. Table data, which can be setup in any location within the Program Memory, is addressed by a separate table pointer register.

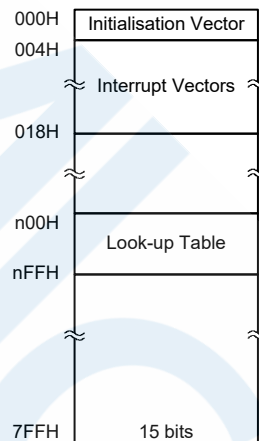

**Program Memory Structure**

### Special Vectors

Within the Program Memory, certain locations are reserved for the reset and interrupts. The location 000H is reserved for use by the device reset for program initialisation. After a device reset is initiated, the program will jump to this location and begin execution.

### Look-up Table

Any location within the Program Memory can be defined as a look-up table where programmers can store fixed data. To use the look-up table, the table pointer must first be setup by placing the address of the look up data to be retrieved in the table pointer register, TBLP. This register defines the total address of the look-up table.

After setting up the table pointer, the table data can be retrieved from the Program Memory using the “TABRD [m]” or “TABRDL [m]” instruction. When the instruction is executed, the lower order table byte from the Program Memory will be transferred to the user defined Data Memory register [m] as specified in the instruction. The higher order table data byte from the Program Memory will be transferred to the TBLH special register.

The accompanying diagram illustrates the addressing data flow of the look-up table.

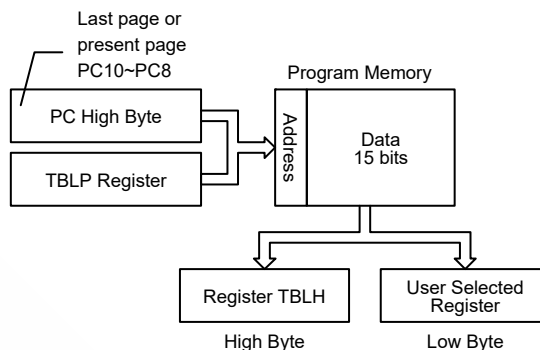

### Table Program Example

The following example shows how the table pointer and table data is defined and retrieved from the microcontroller. This example uses raw table data located in the Program Memory which is stored there using the ORG statement. The value at this ORG statement is "0700H" which refers to the start address of the last page within the 2K words Program Memory of the microcontroller. The table pointer low byte register is setup here to have an initial value of "06H". This will ensure that the first data read from the data table will be at the Program Memory address "0706H" or 6 locations after the start of the last page. Note that the value for the table pointer is referenced to the specified address pointed by the TBLP register if the "TABRD [m]" instruction is being used. The high byte of the table data which in this case is equal to zero will be transferred to the TBLH register automatically when the "TABRD [m]" instruction is executed.

Because the TBLH register is a read-only register and cannot be restored, care should be taken to ensure its protection if both the main routine and Interrupt Service Routine use table read instructions. If using the table read instructions, the Interrupt Service Routines may change the value of the TBLH and subsequently cause errors if used again by the main routine. As a rule it is recommended that simultaneous use of the table read instructions should be avoided. However, in situations where simultaneous use cannot be avoided, the interrupts should be disabled prior to the execution of any main routine table-read instructions. Note that all table related instructions require two instruction cycles to complete their operation.

### Table Read Program Example

```

tempreg1 db? ; temporary register #1
tempreg2 db? ; temporary register #2
:
:
mov a,06h ; initialise low table pointer - note that this address is referenced
mov tblp,a ; to the last page or present page
:
:
tabrd tempreg1 ; transfers value in table referenced by table pointer
; data at program memory address "0706H" transferred to tempreg1 and TBLH
dec tblp ; reduce value of table pointer by one
tabrd tempreg2 ; transfers value in table referenced by table pointer
; data at program memory address "0705H" transferred to tempreg2 and TBLH
; in this example the data "1AH" is transferred to tempreg1 and data "0FH"
; to tempreg2
; the value "00H" will be transferred to the high byte register TBLH
:
:
org 0700h ; set initial address of last page
dc 00Ah,00Bh,00Ch,00Dh,00Eh,00Fh,01Ah,01Bh

```

### In Circuit Programming – ICP

The provision of Flash type Program Memory provides the user with a means of convenient and easy upgrades and modifications to their programs on the same device.

As an additional convenience, Holtek has provided a means of programming the microcontroller in-circuit using a 4-pin interface. This provides manufacturers with the possibility of manufacturing their circuit boards complete with a programmed or un-programmed microcontroller, and then programming or upgrading the program at a later stage. This enables product manufacturers to easily keep their manufactured products supplied with the latest program releases without removal and re-insertion of the device.

Holtek Writer Pins	MCU Programming Pins	Pin Description
ICPDA	PA0	Programming Serial Data/Address
ICPCK	PA2	Programming Clock
VDD	VDD	Power Supply
VSS	VSS	Ground

The Program Memory can be programmed serially in-circuit using this 4-wire interface. Data is downloaded and uploaded serially on a single pin with an additional line for the clock. Two additional lines are required for the power supply. The technical details regarding the in-circuit programming of the device is beyond the scope of this document and will be supplied in supplementary literature.

During the programming process, the user must take care of the ICPDA and ICPCK pins for data and clock programming purposes to ensure that no other outputs are connected to these two pins.

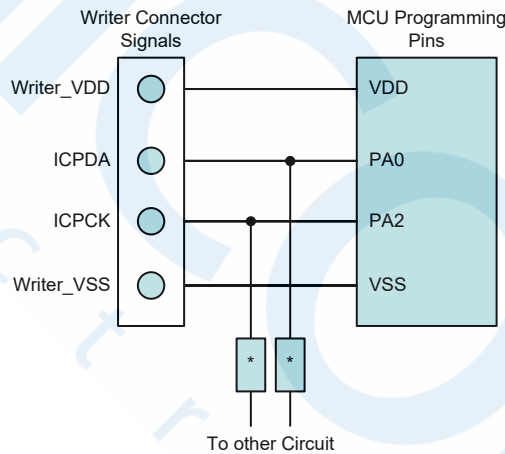

Note: \* may be resistor or capacitor. The resistance of \* must be greater than 1k $\Omega$  or the capacitance of \* must be less than 1nF.

### On-Chip Debug Support – OCDS

There is an EV chip named HT45V5Q-2A which is used to emulate the HT45F5Q-2A device. This EV chip device also provides an “On-Chip Debug” function to debug the real MCU device during the development process. The EV chip and the real MCU device are almost functionally compatible except for “On-Chip Debug” function. Users can use the EV chip device to emulate the real chip device behavior by connecting the OCSDSA and OCDSCK pins to the Holtek HT-IDE development tools. The OCSDSA pin is the OCDS Data/Address input/output pin while the OCDSCK pin is the OCDS clock input pin. When users use the EV chip for debugging, other functions which are shared with the OCSDSA and OCDSCK pins in the device will have no effect in the EV chip. However, the two OCDS pins which are pin-shared with the ICP programming pins are still used as the Flash Memory programming pins for ICP. For more detailed OCDS information, refer to the corresponding document named “Holtek e-Link for 8-bit MCU OCDS User’s Guide”.

Holtek e-Link Pins	EV Chip Pins	Pin Description
OCSDSA	OCSDSA	On-Chip Debug Support Data/Address input/output
OCDSCK	OCDSCK	On-Chip Debug Support Clock input
VDD	VDD	Power Supply
VSS	VSS	Ground

### Data Memory

The Data Memory is a volatile area of 8-bit wide RAM internal memory and is the location where temporary information is stored.

#### Structure

Categorized into two types, the first of these is an area of RAM where special function registers are located. These registers have fixed locations and are necessary for correct operation of the device. Many of these registers can be read from and written to directly under program control, however, some remain protected from user manipulation. The second area of Data Memory is reserved for general purpose use. All locations within this area are read and write accessible under program control.

The start address of the Data Memory for the device is 00H. The address range of the Special Purpose Data Memory for the device is from 00H to 7FH while the address range of the General Purpose Data Memory is from 80H to FFH.

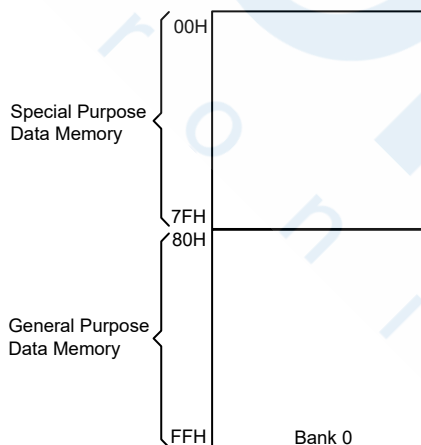

**Data Memory Structure**

### **General Purpose Data Memory**

All microcontroller programs require an area of read/write memory where temporary data can be stored and retrieved for use later. It is this area of RAM memory that is known as General Purpose Data Memory. This area of Data Memory is fully accessible by the user programing for both reading and writing operations. By using the bit operation instructions individual bits can be set or reset under program control giving the user a large range of flexibility for bit manipulation in the Data Memory.

### **Special Purpose Data Memory**

This area of Data Memory is where registers, necessary for the correct operation of the microcontroller, are stored. Most of the registers are both readable and writeable but some are protected and are readable only, the details of which are located under the relevant Special Function Register section. Note that for locations that are unused, any read instruction to these addresses will return the value "00H".



Bank 0		Bank 0	
00H	IAR0	40H	
01H	MP0	41H	ECR
02H	IAR1	42H	EAR
03H	MP1	43H	ED0L
04H		44H	ED0H
05H	ACC	45H	ED1L
06H	PCL	46H	ED1H
07H	TBLP	47H	ED2L
08H	TBLH	48H	ED2H
09H		49H	ED3L
0AH	STATUS	4AH	ED3H
0BH		4BH	
0CH		4CH	
0DH		4DH	
0EH		4EH	
0FH	RSTFC	4FH	
10H	SADC0	50H	
11H	SADC1	51H	
12H	SAD0H	52H	
13H	SAD0L	53H	
14H	PA	54H	
15H	PAC	55H	
16H	PAPU	56H	
17H	PAWU	57H	
18H	PB	58H	
19H	PBC	59H	
1AH	PBPU	5AH	
1BH	SCC	5BH	
1CH	HIRCC	5CH	
1DH	TB0C	5DH	
1EH	TB1C	5EH	
1FH	USR	5FH	
20H	UCR1	60H	
21H	UCR2	61H	
22H	UCR3	62H	
23H	TXR_RXR	63H	
24H	BRG	64H	
25H	CTMC0	65H	
26H	CTMC1	66H	
27H	CTMDL	67H	
28H	CTMDH	68H	
29H	CTMAL	69H	
2AH	CTMAH	6AH	
2BH	INTC0	6BH	
2CH	INTC1	6CH	
2DH	MFI	6DH	
2EH	WDTC	6EH	
2FH	INTEG	6FH	
30H	LVRC	70H	
31H	TLVRC	71H	
32H	DA0L	72H	
33H	DA0H	73H	
34H	DA1L	74H	
35H	DA1H	75H	
36H	DAOPC	76H	
37H	OPVOS	77H	
38H	PAS0	78H	
39H	PAS1	79H	
3AH	PBS0	7AH	
3BH	PBS1	7BH	
3CH	PSCR	7CH	
3DH	IFS	7DH	
3EH		7EH	
3FH		7FH	

 : Unused, read as 00H

**Special Purpose Data Memory**

## Special Function Register Description

Most of the Special Function Register details will be described in the relevant functional section; however several registers require a separate description in this section.

### Indirect Addressing Registers – IAR0, IAR1

The Indirect Addressing Registers, IAR0 and IAR1, although having their locations in normal RAM register space, do not actually physically exist as normal registers. The method of indirect addressing for RAM data manipulation uses these Indirect Addressing Registers and Memory Pointers, in contrast to direct memory addressing, where the actual memory address is specified. Actions on the IAR0 and IAR1 registers will result in no actual read or write operation to these registers but rather to the memory location specified by their corresponding Memory Pointers, MP0 or MP1. Acting as a pair, IAR0 and MP0 can together access data only from Bank 0 while the IAR1 and MP1 register pair can access data from any bank. As the Indirect Addressing Registers are not physically implemented, reading the Indirect Addressing Registers indirectly will return a result of “00H” and writing to the registers indirectly will result in no operation.

### Memory Pointers – MP0, MP1

Two Memory Pointers, known as MP0 and MP1 are provided. These Memory Pointers are physically implemented in the Data Memory and can be manipulated in the same way as normal registers providing a convenient way with which to address and track data. When any operation to the relevant Indirect Addressing Registers is carried out, the actual address that the microcontroller is directed to is the address specified by the related Memory Pointer. MP0, together with Indirect Addressing Register, IAR0, are used to access data from Bank 0, while MP1 and IAR1 are used to access data from all banks. Direct Addressing can only be used with Bank 0, all other Banks must be addressed indirectly using MP1 and IAR1.

The following example shows how to clear a section of four Data Memory locations already defined as locations adres1 to adres4.

### Indirect Addressing Program Example

```
data .section 'data'
adres1 db ?
adres2 db ?
adres3 db ?
adres4 db ?
block db ?
code .section at 0 'code'
org 00h
start:
    mov a, 04h          ; setup size of block
    mov block, a
    mov a, offset adres1 ; Accumulator loaded with first RAM address
    mov mp0, a         ; setup memory pointer with first RAM address
loop:
    clr IAR0           ; clear the data at address defined by MP0
    inc mp0            ; increment memory pointer
    sdz block          ; check if last memory location has been cleared
    jmp loop
continue:
```

The important point to note here is that in the examples shown above, no reference is made to specific Data Memory addresses.

### **Accumulator – ACC**

The Accumulator is central to the operation of any microcontroller and is closely related with operations carried out by the ALU. The Accumulator is the place where all intermediate results from the ALU are stored. Without the Accumulator it would be necessary to write the result of each calculation or logical operation such as addition, subtraction, shift, etc., to the Data Memory resulting in higher programming and timing overheads. Data transfer operations usually involve the temporary storage function of the Accumulator; for example, when transferring data between one user-defined register and another, it is necessary to do this by passing the data through the Accumulator as no direct transfer between two registers is permitted.

### **Program Counter Low Byte Register – PCL**

To provide additional program control functions, the low byte of the Program Counter is made accessible to programmers by locating it within the Special Purpose area of the Data Memory. By manipulating this register, direct jumps to other program locations are easily implemented. Loading a value directly into this PCL register will cause a jump to the specified Program Memory location, however, as the register is only 8-bit wide, only jumps within the current Program Memory page are permitted. When such operations are used, note that a dummy cycle will be inserted.

### **Look-up Table Registers – TBLP, TBLH**

These two special function registers are used to control operation of the look-up table which is stored in the Program Memory. TBLP is the table pointer and indicates the location where the table data is located. Its value must be setup before any table read commands are executed. Its value can be changed, for example using the “INC” or “DEC” instructions, allowing for easy table data pointing and reading. TBLH is the location where the high order byte of the table data is stored after a table read data instruction has been executed. Note that the lower order table data byte is transferred to a user defined location.

### **Status Register – STATUS**

This 8-bit register contains the zero flag (Z), carry flag (C), auxiliary carry flag (AC), overflow flag (OV), power down flag (PDF), and watchdog time-out flag (TO). These arithmetic/logical operation and system management flags are used to record the status and operation of the microcontroller.

With the exception of the TO and PDF flags, bits in the status register can be altered by instructions like most other registers. Any data written into the status register will not change the TO or PDF flag. In addition, operations related to the status register may give different results due to the different instruction operations. The TO flag can be affected only by a system power-up, a WDT time-out or by executing the “CLR WDT” or “HALT” instruction. The PDF flag is affected only by executing the “HALT” or “CLR WDT” instruction or during a system power-up.

The Z, OV, AC, and C flags generally reflect the status of the latest operations.

- C is set if an operation results in a carry during an addition operation or if a borrow does not take place during a subtraction operation; otherwise C is cleared. C is also affected by a rotate through carry instruction.
- AC is set if an operation results in a carry out of the low nibbles in addition, or no borrow from the high nibble into the low nibble in subtraction; otherwise AC is cleared.
- Z is set if the result of an arithmetic or logical operation is zero; otherwise Z is cleared.
- OV is set if an operation results in a carry into the highest-order bit but not a carry out of the highest-order bit, or vice versa; otherwise OV is cleared.

- PDF is cleared by a system power-up or executing the “CLR WDT” instruction. PDF is set by executing the “HALT” instruction.
- TO is cleared by a system power-up or executing the “CLR WDT” or “HALT” instruction. TO is set by a WDT time-out.

In addition, on entering an interrupt sequence or executing a subroutine call, the status register will not be pushed onto the stack automatically. If the contents of the status registers are important and if the subroutine can corrupt the status register, precautions must be taken to correctly save it.

• **STATUS Register**

Bit	7	6	5	4	3	2	1	0
Name	—	—	TO	PDF	OV	Z	AC	C
R/W	—	—	R	R	R/W	R/W	R/W	R/W
POR	—	—	0	0	x	x	x	x

“x”: unknown

- Bit 7~6 Unimplemented, read as “0”
- Bit 5 **TO**: Watchdog Time-out flag  
0: After power up or executing the “CLR WDT” or “HALT” instruction  
1: A watchdog time-out occurred
- Bit 4 **PDF**: Power down flag  
0: After power up or executing the “CLR WDT” instruction  
1: By executing the “HALT” instruction
- Bit 3 **OV**: Overflow flag  
0: No overflow  
1: An operation results in a carry into the highest-order bit but not a carry out of the highest-order bit or vice versa
- Bit 2 **Z**: Zero flag  
0: The result of an arithmetic or logical operation is not zero  
1: The result of an arithmetic or logical operation is zero
- Bit 1 **AC**: Auxiliary flag  
0: No auxiliary carry  
1: An operation results in a carry out of the low nibbles in addition, or no borrow from the high nibble into the low nibble in subtraction
- Bit 0 **C**: Carry flag  
0: No carry-out  
1: An operation results in a carry during an addition operation or if a borrow does not take place during a subtraction operation  
The “C” flag is also affected by a rotate through carry instruction.

## Emulated EEPROM Data Memory

The device contains an Emulated EEPROM Data Memory, which is by its nature a non-volatile form of re-programmable memory, with data retention even when its power supply is removed. By incorporating this kind of data memory, a whole new host of application possibilities are made available to the designer. The availability of the Emulated EEPROM storage allows information such as product identification numbers, calibration values, specific user data, system setup data or other product information to be stored directly within the product microcontroller.

### Emulated EEPROM Data Memory Structure

The Emulated EEPROM Data Memory capacity is 32×15 bits for the device. The Emulated EEPROM Erase operation is carried out in a page format while the Write operation is carried out in 4-word format and the Read operation in a word format. The page size is assigned with a capacity of 16 words. Note that the Erase operation should be executed before the Write operation is executed.

Operations	Format
Erase	1 page/time
Write	4 words/time
Read	1 word/time

Note: Page size=16 words

#### Emulated EEPROM Erase/Write/Read Format

Erase Page	EAR4	EAR[3:0]
0	0	xxxx
1	1	xxxx

“x”: don't care

#### Erase Page Number and Selection

Write Unit	EAR[4:2]	EAR[1:0]
0	000	xx
1	001	xx
2	010	xx
3	011	xx
4	100	xx
5	101	xx
6	110	xx
7	111	xx

“x”: don't care

#### Write Unit Number and Selection

### Emulated EEPROM Registers

Several registers control the overall operation of the Emulated EEPROM Data Memory. These are the address register, EAR, the data registers, ED0L/ED0H~ED3L/ED3H, and a single control register, ECR.

Register Name	Bit							
	7	6	5	4	3	2	1	0
EAR	—	—	—	EAR4	EAR3	EAR2	EAR1	EAR0
ED0L	D7	D6	D5	D4	D3	D2	D1	D0
ED0H	—	D14	D13	D12	D11	D10	D9	D8
ED1L	D7	D6	D5	D4	D3	D2	D1	D0

Register Name	Bit							
	7	6	5	4	3	2	1	0
ED1H	—	D14	D13	D12	D11	D10	D9	D8
ED2L	D7	D6	D5	D4	D3	D2	D1	D0
ED2H	—	D14	D13	D12	D11	D10	D9	D8
ED3L	D7	D6	D5	D4	D3	D2	D1	D0
ED3H	—	D14	D13	D12	D11	D10	D9	D8
ECR	EWRTS1	EWRTS0	EEREN	EER	EWREN	EWR	ERDEN	ERD

**Emulated EEPROM Register List**
**• EAR Register**

Bit	7	6	5	4	3	2	1	0
Name	—	—	—	EAR4	EAR3	EAR2	EAR1	EAR0
R/W	—	—	—	R/W	R/W	R/W	R/W	R/W
POR	—	—	—	0	0	0	0	0

Bit 7~5 Unimplemented, read as “0”

 Bit 4~0 **EAR4~EAR0**: Emulated EEPROM address bit 4 ~ bit 0

**• ED0L Register**

Bit	7	6	5	4	3	2	1	0
Name	D7	D6	D5	D4	D3	D2	D1	D0
R/W	R/W	R/W	R/W	R/W	R/W	R/W	R/W	R/W
POR	0	0	0	0	0	0	0	0

 Bit 7~0 **D7~D0**: The first Emulated EEPROM data bit 7 ~ bit 0

**• ED0H Register**

Bit	7	6	5	4	3	2	1	0
Name	—	D14	D13	D12	D11	D10	D9	D8
R/W	—	R/W	R/W	R/W	R/W	R/W	R/W	R/W
POR	—	0	0	0	0	0	0	0

Bit 7 Unimplemented, read as “0”

 Bit 6~0 **D14~D8**: The first Emulated EEPROM data bit 14 ~ bit 8

**• ED1L Register**

Bit	7	6	5	4	3	2	1	0
Name	D7	D6	D5	D4	D3	D2	D1	D0
R/W	R/W	R/W	R/W	R/W	R/W	R/W	R/W	R/W
POR	0	0	0	0	0	0	0	0

 Bit 7~0 **D7~D0**: The second Emulated EEPROM data bit 7 ~ bit 0

**• ED1H Register**

Bit	7	6	5	4	3	2	1	0
Name	—	D14	D13	D12	D11	D10	D9	D8
R/W	—	R/W	R/W	R/W	R/W	R/W	R/W	R/W
POR	—	0	0	0	0	0	0	0

Bit 7 Unimplemented, read as “0”

 Bit 6~0 **D14~D8**: The second Emulated EEPROM data bit 14 ~ bit 8

• **ED2L Register**

Bit	7	6	5	4	3	2	1	0
Name	D7	D6	D5	D4	D3	D2	D1	D0
R/W	R/W	R/W	R/W	R/W	R/W	R/W	R/W	R/W
POR	0	0	0	0	0	0	0	0

Bit 7~0 **D7~D0**: The third Emulated EEPROM data bit 7 ~ bit 0

• **ED2H Register**

Bit	7	6	5	4	3	2	1	0
Name	—	D14	D13	D12	D11	D10	D9	D8
R/W	—	R/W	R/W	R/W	R/W	R/W	R/W	R/W
POR	—	0	0	0	0	0	0	0

Bit 7 Unimplemented, read as “0”

Bit 6~0 **D14~D8**: The third Emulated EEPROM data bit 14 ~ bit 8

• **ED3L Register**

Bit	7	6	5	4	3	2	1	0
Name	D7	D6	D5	D4	D3	D2	D1	D0
R/W	R/W	R/W	R/W	R/W	R/W	R/W	R/W	R/W
POR	0	0	0	0	0	0	0	0

Bit 7~0 **D7~D0**: The fourth Emulated EEPROM data bit 7 ~ bit 0

• **ED3H Register**

Bit	7	6	5	4	3	2	1	0
Name	—	D14	D13	D12	D11	D10	D9	D8
R/W	—	R/W	R/W	R/W	R/W	R/W	R/W	R/W
POR	—	0	0	0	0	0	0	0

Bit 7 Unimplemented, read as “0”

Bit 6~0 **D14~D8**: The fourth Emulated EEPROM data bit 14 ~ bit 8

• **ECR Register**

Bit	7	6	5	4	3	2	1	0
Name	EWRTS1	EWRTS0	EEREN	EER	EWREN	EWR	ERDEN	ERD
R/W	R/W	R/W	R/W	R/W	R/W	R/W	R/W	R/W
POR	0	0	0	0	0	0	0	0

Bit 7~6 **EWRTS1~EWRTS0**: Emulated EEPROM Erase/Write time selection  
 00: 2ms  
 01: 4ms  
 10: 8ms  
 11: 16ms

Bit 5 **EEREN**: Emulated EEPROM Erase enable  
 0: Disable  
 1: Enable

This bit is used to enable the Emulated EEPROM erase function and must be set high before erase operations are carried out. This bit will be automatically reset to zero by the hardware after the erase cycle has finished. Clearing this bit to zero will inhibit the Emulated EEPROM erase operations.

- Bit 4     **EER**: Emulated EEPROM Erase control  
           0: Erase cycle has finished  
           1: Activate an erase cycle  
 When this bit is set high by the application program, an erase cycle will be activated. This bit will be automatically reset to zero by the hardware after the erase cycle has finished. Setting this bit high will have no effect if the EEREN has not first been set high.
- Bit 3     **EWREN**: Emulated EEPROM Write enable  
           0: Disable  
           1: Enable  
 This bit is used to enable the Emulated EEPROM write function and must be set high before write operations are carried out. This bit will be automatically reset to zero by the hardware after the write cycle has finished. Clearing this bit to zero will inhibit the Emulated EEPROM write operations.
- Bit 2     **EWR**: Emulated EEPROM Write control  
           0: Write cycle has finished  
           1: Activate a write cycle  
 When this bit is set high by the application program, a write cycle will be activated. This bit will be automatically reset to zero by the hardware after the write cycle has finished. Setting this bit high will have no effect if the EWREN has not first been set high.
- Bit 1     **ERDEN**: Emulated EEPROM Read enable  
           0: Disable  
           1: Enable  
 This bit is used to enable the Emulated EEPROM read function and must be set high before read operations are carried out. Clearing this bit to zero will inhibit the Emulated EEPROM read operations.
- Bit 0     **ERD**: Emulated EEPROM Read control  
           0: Read cycle has finished  
           1: Activate a read cycle  
 When this bit is set high by the application program, a read cycle will be activated. This bit will be automatically reset to zero by the hardware after the read cycle has finished. Setting this bit high will have no effect if the ERDEN has not first been set high.

- Note: 1. The EEREN, EER, EWREN, EWR, ERDEN and ERD cannot be set to “1” at the same time in one instruction.  
 2. Note that the CPU will be stopped when a read, write or erase operation is successfully activated.  
 3. Ensure that the  $f_{SYS}$  clock frequency is equal to or greater than 2MHz and the  $f_{SUB}$  clock is stable before executing the erase or write operation.  
 4. Ensure that the read, write or erase operation is totally complete before executing other operations.

### Erasing the Emulated EEPROM

For Emulated EEPROM erase operation the desired erase page address should first be placed in the EAR register. The number of the erase operation is 16 words per page each time, therefore, the available page erase address is only specified by the EAR4 bit in the EAR register and the content of EAR3~EAR0 in the EAR register is not used to specify the page address. To erase the Emulated EEPROM page, the EEREN bit in the ECR register must first be set high to enable the erase function. After this the EER bit in the ECR register must be immediately set high to initiate an erase cycle. These two instructions must be executed in two consecutive instruction cycles to activate an erase operation successfully. The global interrupt bit EMI should also first be cleared before implementing any erase operations, and then set high again after a valid erase activation procedure



has completed. Note that the CPU will be stopped when an erase operation is successfully activated. When the erase cycle terminates, the CPU will resume executing the application program. And the EER bit will be automatically cleared to zero by the microcontroller, informing the user that the data has been erased. The Emulated EEPROM erased page content will all be zero after an erase operation.

### **Writing Data to the Emulated EEPROM**

For Emulated EEPROM write operation the desired write unit address should first be placed in the EAR register and the data placed in the ED0L/ED0H~ED3L/ED3H registers. The number of the write operation is 4 words each time, therefore, the available write unit address is only specified by the EAR4~EAR2 bits in the EAR register and the content of EAR1~EAR0 in the EAR register is not used to specify the unit address. To write data to the Emulated EEPROM, the EWREN bit in the ECR register must first be set high to enable the write function. After this the EWR bit in the ECR register must be immediately set high to initiate a write cycle. These two instructions must be executed in two consecutive instruction cycles to activate a write operation successfully. The global interrupt bit EMI should also first be cleared before implementing any write operations, and then set high again after a valid write activation procedure has completed. Note that the CPU will be stopped when a write operation is successfully activated. When the write cycle terminates, the CPU will resume executing the application program. And the EWR bit will be automatically cleared to zero by the microcontroller, informing the user that the data has been written to the Emulated EEPROM.

### **Reading Data from the Emulated EEPROM**

For Emulated EEPROM read operation the desired read address should first be placed in the EAR register. To read data from the Emulated EEPROM, the ERDEN bit in the ECR register must first be set high to enable the read function. After this a read cycle will be initiated if the ERD bit in the ECR register is now set high. Note that the CPU will be stopped when the read operation is successfully activated. When the read cycle terminates, the CPU will resume executing the application program. And the ERD bit will be automatically cleared to zero by the microcontroller, informing the user that the data has been read from the Emulated EEPROM. Then the data can be read from the ED0H/ED0L data register pair by application program. The data will remain in the data register pair until another read, write or erase operation is executed.

### **Programming Considerations**

Care must be taken that data is not inadvertently written to the Emulated EEPROM. Protection can be enhanced by ensuring that the Write Enable bit is normally cleared to zero when not writing. Although certainly not necessary, consideration might be given in the application program to the checking of the validity of new write data by a simple read back process. When writing or erasing data the EWR or EER bit must be set high immediately after the EWREN or EEREN bit has been set high, to ensure the write or erase cycle executes correctly. The global interrupt bit EMI should also be cleared before a write or erase cycle is executed and then set high again after a valid write or erase activation procedure has completed. Note that the device should not enter the IDLE or SLEEP mode until Emulated EEPROM read, write or erase operation is totally complete. Otherwise, Emulated EEPROM read, write or erase operation will fail.

### Programming Examples

#### Erase a Data Page of the Emulated EEPROM – polling method

```

MOV A, EEPROM_ADRES      ; user-defined page
MOV EAR, A
MOV A, 00H                ; Erase time=2ms (40H for 4ms, 80H for 8ms, C0H for 16ms)
MOV ECR, A
CLR EMI
SET EEREN                 ; set EEREN bit, enable erase operation
SET EER                   ; start Erase Cycle - set EER bit - executed immediately
                           ; after setting EEREN bit

SET EMI
BACK:
SZ EER                    ; check for erase cycle end
JMP BACK
:

```

#### Writing Data to the Emulated EEPROM – polling method

```

MOV A, EEPROM_ADRES      ; user-defined address
MOV EAR, A
MOV A, EEPROM_DATA0_L    ; user-defined data
MOV ED0L, A
MOV A, EEPROM_DATA0_H
MOV ED0H, A
MOV A, EEPROM_DATA1_L
MOV ED1L, A
MOV A, EEPROM_DATA1_H
MOV ED1H, A
MOV A, EEPROM_DATA2_L
MOV ED2L, A
MOV A, EEPROM_DATA2_H
MOV ED2H, A
MOV A, EEPROM_DATA3_L
MOV ED3L, A
MOV A, EEPROM_DATA3_H
MOV ED3H, A
MOV A, 00H                ; Write time=2ms (40H for 4ms, 80H for 8ms, C0H for 16ms)
MOV ECR, A
CLR EMI
SET EWREN                 ; set EWREN bit, enable write operation
SET EWR                   ; start Write Cycle - set EWR bit - executed immediately
                           ; after set EWREN bit

SET EMI
BACK:
SZ EWR                    ; check for write cycle end
JMP BACK
:

```

**Reading Data from the Emulated EEPROM – polling method**

```

MOV A, EEPROM_ADRES      ; user-defined address
MOV EAR, A
SET ERDEN                ; set ERDEN bit, enable read operation
SET ERD                  ; start Read Cycle - set ERD bit
BACK:
SZ ERD                  ; check for read cycle end
JMP BACK
CLR ECR                  ; disable Emulated EEPROM read if no more read operations
                        ; are required
MOV A, ED0L              ; move read data which is placed in the ED0L/ED0H
                        ; to user-defined registers

MOV READ_DATA_L, A
MOV A, ED0H
MOV READ_DATA_H, A
    
```

Note: For each read operation, the address register should be re-specified followed by setting the ERD bit high to activate a read cycle even if the target address is consecutive.

**Oscillators**

Various oscillator options offer the user a wide range of functions according to their various application requirements. The flexible features of the oscillator functions ensure that the best optimisation can be achieved in terms of speed and power saving. Oscillator selections and operation are selected through the application program by using relevant control registers.

**Oscillator Overview**

In addition to being the source of the main system clock the oscillators also provide clock sources for the Watchdog Timer and Time Base Interrupts. Two fully integrated internal oscillators, requiring no external components, are provided to form a wide range of both fast and slow system oscillators. The higher frequency oscillator provides higher performance but carry with it the disadvantage of higher power requirements, while the opposite is of course true for the lower frequency oscillators. With the capability of dynamically switching between fast and slow system clock, the device has the flexibility to optimize the performance/power ratio, a feature especially important in power sensitive portable applications.

Type	Name	Frequency
Internal High Speed RC	HIRC	8MHz
Internal Low Speed RC	LIRC	32kHz

**Oscillator Types**

**System Clock Configurations**

There are two oscillator sources, a high speed oscillator and a low speed oscillator. The high speed oscillator is the internal 8MHz RC oscillator, HIRC. The low speed oscillator is the internal 32kHz RC oscillator, LIRC. Selecting whether the low or high speed oscillator is used as the system oscillator is implemented using the CKS2~CKS0 bits in the SCC register and as the system clock can be dynamically selected.

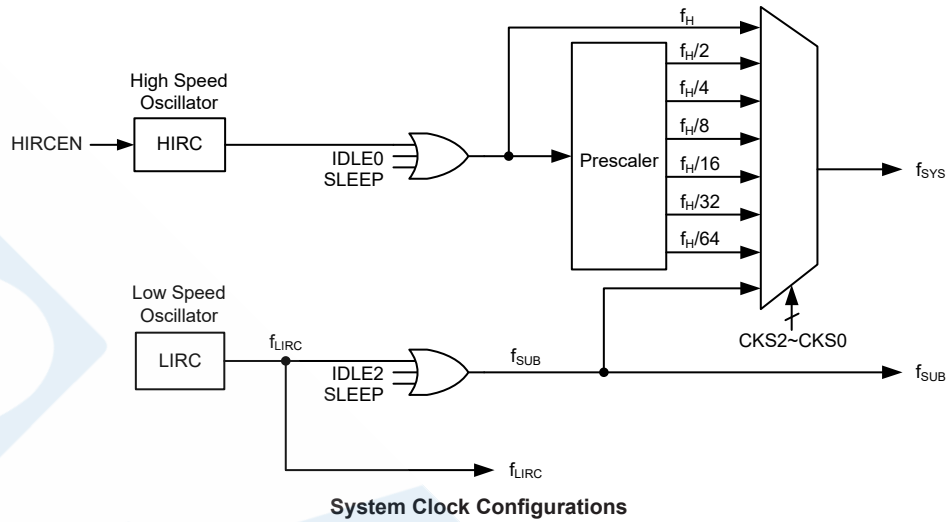

### Internal High Speed RC Oscillator – HIRC

The internal high speed RC oscillator is a fully integrated system oscillator requiring no external components. The internal RC oscillator has a fixed frequency of 8MHz. Device trimming during the manufacturing process and the inclusion of internal frequency compensation circuits are used to ensure that the influence of the power supply voltage, temperature and process variations on the oscillation frequency are minimized.

### Internal 32kHz Oscillator – LIRC

The Internal 32kHz System Oscillator is the low frequency oscillator. It is a fully integrated RC oscillator with a typical frequency of 32kHz, requiring no external components for its implementation. Device trimming during the manufacturing process and the inclusion of internal frequency compensation circuits are used to ensure that the influence of the power supply voltage, temperature and process variations on the oscillation frequency are minimized.

## Operating Modes and System Clocks

Present day applications require that their microcontrollers have high performance but often still demand that they consume as little power as possible, conflicting requirements that are especially true in battery powered portable applications. The fast clocks required for high performance will by their nature increase current consumption and of course vice versa, lower speed clocks reduce current consumption. As Holtek has provided the device with both high and low speed clock sources and the means to switch between them dynamically, the user can optimise the operation of their microcontroller to achieve the best performance/power ratio.

### System Clocks

The device has many different clock sources for both the CPU and peripheral function operation. By providing the user with a wide range of clock options using register programming, a clock system can be configured to obtain maximum application performance.

The main system clock, can come from a high frequency,  $f_H$ , or low frequency,  $f_{SUB}$ , source, and is selected using the CKS2~CKS0 bits in the SCC register. The high speed system clock is sourced from the HIRC oscillator. The low speed system clock source is sourced from the LIRC oscillator. The other choice, which is a divided version of the high speed system oscillator has a range of  $f_H/2 \sim f_H/64$ .

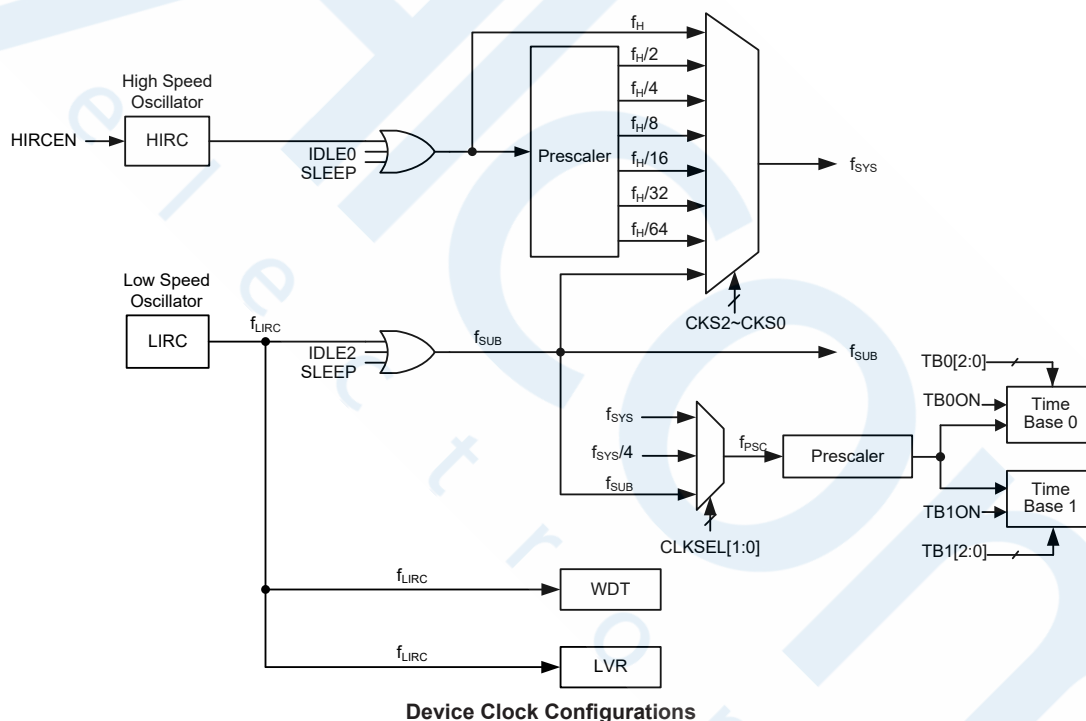

Note: When the system clock source  $f_{SYS}$  is switched to  $f_{SUB}$  from  $f_H$ , the high speed oscillator will stop to conserve the power or continue to oscillate to provide the clock source,  $f_H \sim f_H/64$ , for peripheral circuit to use, which is determined by configuring the corresponding high speed oscillator enable control bit.

### System Operation Modes

There are six different modes of operation for the microcontroller, each one with its own special characteristics and which can be chosen according to the specific performance and

power requirements of the application. There are two modes allowing normal operation of the microcontroller, the FAST Mode and SLOW Mode. The remaining four modes, the SLEEP, IDLE0, IDLE1 and IDLE2 Mode are used when the microcontroller CPU is switched off to conserve power.

Operation Mode	CPU	Register Setting			f <sub>sys</sub>	f <sub>H</sub>	f <sub>SUB</sub>	f <sub>LIRC</sub>
		FHIDEN	FSIDEN	CKS2~CKS0				
FAST	On	x	x	000~110	f <sub>H</sub> ~f <sub>H</sub> /64	On	On	On
SLOW	On	x	x	111	f <sub>SUB</sub>	On/Off <sup>(1)</sup>	On	On
IDLE0	Off	0	1	000~110	Off	Off	On	On
				111	On			
IDLE1	Off	1	1	xxx	On	On	On	On
IDLE2	Off	1	0	000~110	On	On	Off	On
				111	Off			
SLEEP	Off	0	0	xxx	Off	Off	Off	On/Off <sup>(2)</sup>

“x”: Don't care

Note: 1. The f<sub>H</sub> clock will be switched on or off by configuring the corresponding oscillator enable bit in the SLOW mode.

2. The f<sub>LIRC</sub> clock can be switched on or off which is controlled by the WDT function being enabled or disabled in the SLEEP mode.

### FAST Mode

This is one of the main operating modes where the microcontroller has all of its functions operational and where the system clock is provided by the high speed oscillator. This mode operates allowing the microcontroller to operate normally with a clock source will come from the high speed oscillator HIRC. The high speed oscillator will however first be divided by a ratio ranging from 1 to 64, the actual ratio being selected by the CKS2~CKS0 bits in the SCC register. Although a high speed oscillator is used, running the microcontroller at a divided clock ratio reduces the operating current.

### SLOW Mode

This is also a mode where the microcontroller operates normally although now with a slower speed clock source. The clock source used will be from f<sub>SUB</sub>. The f<sub>SUB</sub> clock is derived from the LIRC oscillator.

### SLEEP Mode

The SLEEP Mode is entered when a HALT instruction is executed and when the FHIDEN and FSIDEN bits are low. In the SLEEP mode the CPU will be stopped. The f<sub>SUB</sub> clock provided to the peripheral function will also be stopped, too. However the f<sub>LIRC</sub> clock can continues to operate if the WDT function is enabled.

### IDLE0 Mode

The IDLE0 Mode is entered when a HALT instruction is executed and when the FHIDEN bit in the SCC register is low and the FSIDEN bit in the SCC register is high. In the IDLE0 Mode the CPU will be switched off but the low speed oscillator will be turned on to drive some peripheral functions.

### IDLE1 Mode

The IDLE1 Mode is entered when a HALT instruction is executed and when the FHIDEN bit in the SCC register is high and the FSIDEN bit in the SCC register is high. In the IDLE1 Mode the CPU will be switched off but both the high and low speed oscillators will be turned on to provide a clock source to keep some peripheral functions operational.

### IDLE2 Mode

The IDLE2 Mode is entered when a HALT instruction is executed and when the FHIDEN bit in the SCC register is high and the FSIDEN bit in the SCC register is low. In the IDLE2 Mode the CPU will be switched off but the high speed oscillator will be turned on to provide a clock source to keep some peripheral functions operational.

### Control Registers

The registers, SCC and HIRCC, are used to control the system clock and the HIRC oscillator configurations.

Register Name	Bit							
	7	6	5	4	3	2	1	0
SCC	CKS2	CKS1	CKS0	—	—	—	FHIDEN	FSIDEN
HIRCC	—	—	—	—	—	—	HIRCF	HIRCEN

System Operating Mode Control Register List

#### • SCC Register

Bit	7	6	5	4	3	2	1	0
Name	CKS2	CKS1	CKS0	—	—	—	FHIDEN	FSIDEN
R/W	R/W	R/W	R/W	—	—	—	R/W	R/W
POR	0	0	0	—	—	—	0	0

Bit 7~5 **CKS2~CKS0**: System clock selection

000:  $f_H$   
001:  $f_H/2$   
010:  $f_H/4$   
011:  $f_H/8$   
100:  $f_H/16$   
101:  $f_H/32$   
110:  $f_H/64$   
111:  $f_{SUB}$

These three bits are used to select which clock is used as the system clock source. In addition to the system clock source directly derived from  $f_H$  or  $f_{SUB}$ , a divided version of the high speed system oscillator can also be chosen as the system clock source.

Bit 4~2 Unimplemented, read as “0”

Bit 1 **FHIDEN**: High Frequency oscillator control when CPU is switched off  
0: Disable  
1: Enable

This bit is used to control whether the high speed oscillator is activated or stopped when the CPU is switched off by executing a “HALT” instruction.

Bit 0 **FSIDEN**: Low Frequency oscillator control when CPU is switched off  
0: Disable  
1: Enable

This bit is used to control whether the low speed oscillator is activated or stopped when the CPU is switched off by executing a “HALT” instruction.

Note: A certain delay is required before the relevant clock is successfully switched to the target clock source after any clock switching setup using the CKS2~CKS0 bits. A proper delay time must be arranged before executing the following operations which require immediate reaction with the target clock source.

Clock switching delay time =  $4 \times t_{SYS} + [0 \sim (1.5 \times t_{CURR} + 0.5 \times t_{TAR})]$ , where  $t_{CURR}$  indicates the current clock period,  $t_{TAR}$  indicates the target clock period and  $t_{SYS}$  indicates the current system clock period.

• **HIRCC Register**

Bit	7	6	5	4	3	2	1	0
Name	—	—	—	—	—	—	HIRCF	HIRCEN
R/W	—	—	—	—	—	—	R	R/W
POR	—	—	—	—	—	—	0	1

Bit 7~2 Unimplemented, read as “0”

Bit 1 **HIRCF**: HIRC oscillator stable flag  
0: HIRC unstable  
1: HIRC stable

This bit is used to indicate whether the HIRC oscillator is stable or not. When the HIRCEN bit is set to 1 to enable the HIRC oscillator, the HIRCF bit will first be cleared to 0 and then set to 1 after the HIRC oscillator is stable.

Bit 0 **HIRCEN**: HIRC oscillator enable control  
0: Disable  
1: Enable

**Operating Mode Switching**

The device can switch between operating modes dynamically allowing the user to select the best performance/power ratio for the present task in hand. In this way microcontroller operations that do not require high performance can be executed using slower clocks thus requiring less operating current and prolonging battery life in portable applications.

In simple terms, Mode Switching between the FAST Mode and SLOW Mode is executed using the CKS2~CKS0 bits in the SCC register while Mode Switching from the FAST/SLOW Modes to the SLEEP/IDLE Modes is executed via the HALT instruction. When a HALT instruction is executed, whether the device enters the IDLE Mode or the SLEEP Mode is determined by the condition of the FHIDEN and FSIDEN bits in the SCC register.

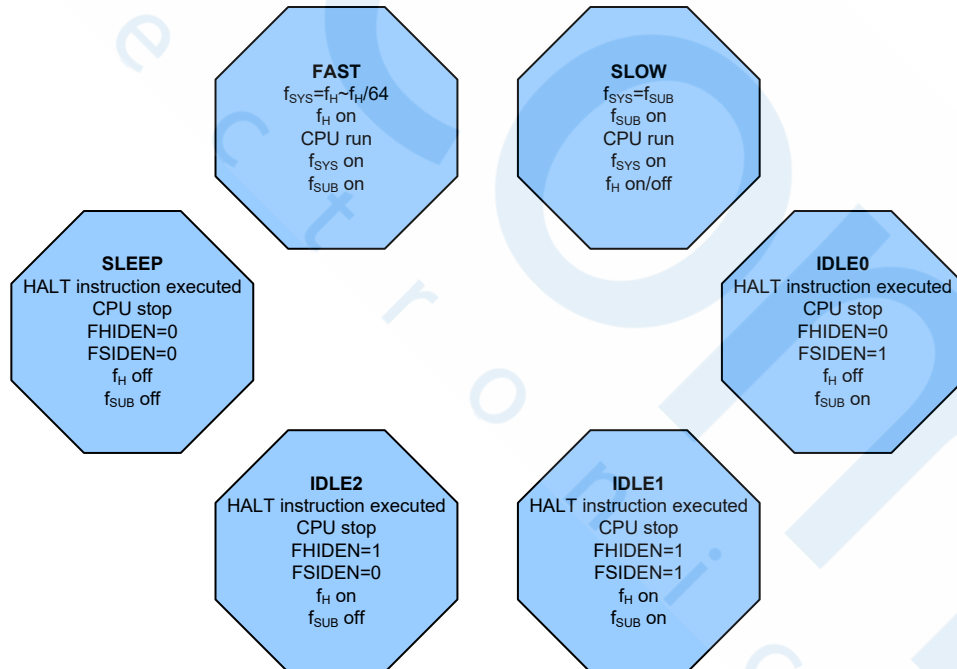



### FAST Mode to SLOW Mode Switching

When running in the FAST Mode, which uses the high speed system oscillator, and therefore consumes more power, the system clock can switch to run in the SLOW Mode by setting the CKS2~CKS0 bits to “111” in the SCC register. This will then use the low speed system oscillator which will consume less power. Users may decide to do this for certain operations which do not require high performance and can subsequently reduce power consumption.

The SLOW Mode is sourced from the LIRC oscillator and therefore requires this oscillator to be stable before full mode switching occurs.

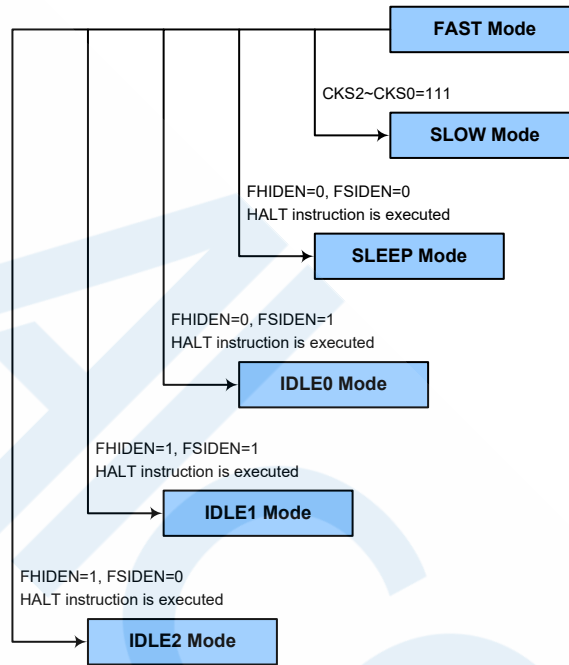

### SLOW Mode to FAST Mode Switching

In SLOW mode the system clock is derived from  $f_{SUB}$ . When system clock is switched back to the FAST mode from  $f_{SUB}$ , the CKS2~CKS0 bits should be set to “000”~“110” and then the system clock will respectively be switched to  $f_H \sim f_H/64$ .

However, if  $f_H$  is not used in SLOW mode and thus switched off, it will take some time to re-oscillate and stabilise when switching to the FAST mode from the SLOW Mode. This is monitored using the HIRCF bit in the HIRCC register. The time duration required for the high speed system oscillator stabilization is specified in the System Start Up Time Characteristics.

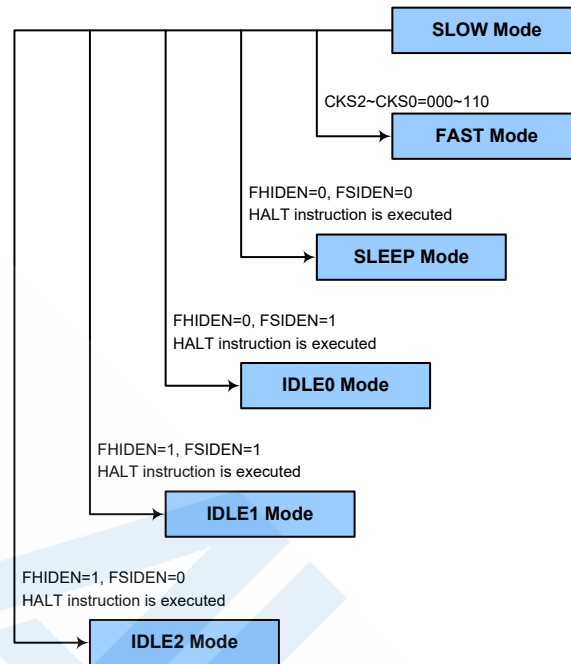

#### Entering the SLEEP Mode

There is only one way for the device to enter the SLEEP Mode and that is to execute the “HALT” instruction in the application program with both the FHIDEN and FSIDEN bits in the SCC register equal to “0”. In this mode all the clocks and functions will be switched off except the WDT function. When this instruction is executed under the conditions described above, the following will occur:

- The system clock will be stopped and the application program will stop at the “HALT” instruction.
- The Data Memory contents and registers will maintain their present condition.
- The I/O ports will maintain their present conditions.
- In the status register, the Power Down flag, PDF, will be set and the Watchdog time-out flag, TO, will be cleared.
- The WDT will be cleared and resume counting if the WDT function is enabled. If the WDT function is disabled, the WDT will be cleared and then stopped.

#### Entering the IDLE0 Mode

There is only one way for the device to enter the IDLE0 Mode and that is to execute the “HALT” instruction in the application program with the FHIDEN bit in the SCC register equal to “0” and the FSIDEN bit in the SCC register equal to “1”. When this instruction is executed under the conditions described above, the following will occur:

- The  $f_H$  clock will be stopped and the application program will stop at the “HALT” instruction, but the  $f_{SUB}$  clock will be on.
- The Data Memory contents and registers will maintain their present condition.
- The I/O ports will maintain their present conditions.
- In the status register, the Power Down flag, PDF, will be set and the Watchdog time-out flag, TO, will be cleared.
- The WDT will be cleared and resume counting if the WDT function is enabled. If the WDT function is disabled, the WDT will be cleared and then stopped.

### Entering the IDLE1 Mode

There is only one way for the device to enter the IDLE1 Mode and that is to execute the “HALT” instruction in the application program with both the FHIDEN and FSIDEN bits in the SCC register equal to “1”. When this instruction is executed under the conditions described above, the following will occur:

- The  $f_{H}$  and  $f_{SUB}$  clocks will be on but the application program will stop at the “HALT” instruction.
- The Data Memory contents and registers will maintain their present condition.
- The I/O ports will maintain their present conditions.
- In the status register, the Power Down flag, PDF, will be set and the Watchdog time-out flag, TO, will be cleared.
- The WDT will be cleared and resume counting if the WDT function is enabled. If the WDT function is disabled, the WDT will be cleared and then stopped.

### Entering the IDLE2 Mode

There is only one way for the device to enter the IDLE2 Mode and that is to execute the “HALT” instruction in the application program with the FHIDEN bit in the SCC register equal to “1” and the FSIDEN bit in the SCC register equal to “0”. When this instruction is executed under the conditions described above, the following will occur:

- The  $f_{H}$  clock will be on but the  $f_{SUB}$  clock will be off and the application program will stop at the “HALT” instruction.
- The Data Memory contents and registers will maintain their present condition.
- The I/O ports will maintain their present conditions.
- In the status register, the Power Down flag, PDF, will be set and the Watchdog time-out flag, TO, will be cleared.
- The WDT will be cleared and resume counting if the WDT function is enabled. If the WDT function is disabled, the WDT will be cleared and then stopped.

### Standby Current Considerations

As the main reason for entering the SLEEP or IDLE Mode is to keep the current consumption of the device to as low a value as possible, perhaps only in the order of several micro-amps except in the IDLE1 and IDLE2 Mode, there are other considerations which must also be taken into account by the circuit designer if the power consumption is to be minimised. Special attention must be made to the I/O pins on the device. All high-impedance input pins must be connected to either a fixed high or low level as any floating input pins could create internal oscillations and result in increased current consumption. This also applies to the device which has different package types, as there may be unbonded pins. These must either be setup as outputs or if setup as inputs must have pull-high resistors connected.

Care must also be taken with the loads, which are connected to I/O pins, which are setup as outputs. These should be placed in a condition in which minimum current is drawn or connected only to external circuits that do not draw current, such as other CMOS inputs. Also note that additional standby current will also be required if the LIRC oscillator has enabled.

In the IDLE1 and IDLE2 Mode the high speed oscillator is on, if the peripheral function clock source is derived from the high speed oscillator, the additional standby current will also be perhaps in the order of several hundred micro-amps.

## Wake-up

To minimise power consumption the device can enter the SLEEP or any IDLE Mode, where the CPU will be switched off. However, when the device is woken up again, it will take a considerable time for the original system oscillator to restart, stabilise and allow normal operation to resume.

After the system enters the SLEEP or IDLE Mode, it can be woken up from one of various sources listed as follows:

- An external falling edge on Port A
- A system interrupt
- A WDT overflow

When the device executes the “HALT” instruction, it will enter the IDLE or SLEEP mode and the PDF flag will be set to 1. The PDF flag will be cleared to 0 if the device experiences a system power-up or executes the clear Watchdog Timer instruction. If the system is woken up by a WDT overflow, a Watchdog Timer reset will be initiated and the TO flag will be set to 1. The TO flag is set if a WDT time-out occurs and causes a wake-up that only resets the Program Counter and Stack Pointer, other flags remain in their original status.

Each pin on Port A can be setup using the PAWU register to permit a negative transition on the pin to wake up the system. When a pin wake-up occurs, the program will resume execution at the instruction following the “HALT” instruction. If the system is woken up by an interrupt, then two possible situations may occur. The first is where the related interrupt is disabled or the interrupt is enabled but the stack is full, in which case the program will resume execution at the instruction following the “HALT” instruction. In this situation, the interrupt which woke up the device will not be immediately serviced, but will rather be serviced later when the related interrupt is finally enabled or when a stack level becomes free. The other situation is where the related interrupt is enabled and the stack is not full, in which case the regular interrupt response takes place. If an interrupt request flag is set high before entering the SLEEP or IDLE Mode, the wake-up function of the related interrupt will be disabled.

## Watchdog Timer

The Watchdog Timer is provided to prevent program malfunctions or sequences from jumping to unknown locations, due to certain uncontrollable external events such as electrical noise.

### Watchdog Timer Clock Source

The Watchdog Timer clock source is provided by the internal clock,  $f_{LIRC}$ , which is sourced from the LIRC oscillator. The LIRC internal oscillator has an approximate frequency of 32kHz and this specified internal clock period can vary with  $V_{DD}$ , temperature and process variations. The Watchdog Timer source clock is then subdivided by a ratio of  $2^8$  to  $2^{15}$  to give longer timeouts, the actual value being chosen using the WS2~WS0 bits in the WDTC register.

### Watchdog Timer Control Register

A single register, WDTC, controls the required time-out period as well as the Watchdog Timer enable/disable and the MCU reset operation.

#### • WDTC Register

Bit	7	6	5	4	3	2	1	0
Name	WE4	WE3	WE2	WE1	WE0	WS2	WS1	WS0
R/W	R/W	R/W	R/W	R/W	R/W	R/W	R/W	R/W
POR	0	1	0	1	0	0	1	1

Bit 7~3 **WE4~WE0**: WDT function software control

10101: Disable

01010: Enable

Other values: Reset MCU

When these bits are changed to any other values due to the environmental noise the microcontroller will be reset; this reset operation will be activated after a delay time,  $t_{SRESET}$ , and the WRF bit in the RSTFC register will be set high.

Bit 2~0 **WS2~WS0**: WDT time-out period selection

000:  $2^8/f_{LIRC}$

001:  $2^9/f_{LIRC}$

010:  $2^{10}/f_{LIRC}$

011:  $2^{11}/f_{LIRC}$

100:  $2^{12}/f_{LIRC}$

101:  $2^{13}/f_{LIRC}$

110:  $2^{14}/f_{LIRC}$

111:  $2^{15}/f_{LIRC}$

These three bits determine the division ratio of the Watchdog Timer source clock, which in turn determines the timeout period.

#### • RSTFC Register

Bit	7	6	5	4	3	2	1	0
Name	—	—	—	—	—	LVRF	LRF	WRF
R/W	—	—	—	—	—	R/W	R/W	R/W
POR	—	—	—	—	—	x	0	0

“x”: unknown

Bit 7~3 Unimplemented, read as “0”

Bit 2 **LVRF**: LVR function reset flag

Refer to the Low Voltage Reset section.

Bit 1 **LRF**: LVR control register software reset flag

Refer to the Low Voltage Reset section.

Bit 0 **WRF**: WDT control register software reset flag  
 0: Not occurred  
 1: Occurred

This bit is set to 1 by the WDT control register software reset and cleared by the application program. Note that this bit can only be cleared to 0 by the application program.

### Watchdog Timer Operation

The Watchdog Timer operates by providing a device reset when its timer overflows. This means that in the application program and during normal operation the user has to strategically clear the Watchdog Timer before it overflows to prevent the Watchdog Timer from executing a reset. This is done using the clear watchdog instruction. If the program malfunctions for whatever reason, jumps to an unknown location, or enters an endless loop, the clear WDT instruction will not be executed in the correct manner, in which case the Watchdog Timer will overflow and reset the device. There are five bits, WE4~WE0, in the WDTC register to offer the enable/disable control of the Watchdog Timer and the MCU reset. The WDT function will be disabled when the WE4~WE0 bits are set to a value of 10101B while the WDT function will be enabled if the WE4~WE0 bits are equal to 01010B. If the WE4~WE0 bits are set to any other values, other than 01010B and 10101B, it will reset the device after a delay time,  $t_{SRESET}$ . After power-on these bits will have a value of 01010B.

WE4~WE0 Bits	WDT Function
10101B	Disable
01010B	Enable
Any other values	Reset MCU

#### Watchdog Timer Enable/Disable Control

Under normal program operation, a Watchdog Timer time-out will initialise a device reset and set the status bit TO. However, if the system is in the SLEEP or IDLE Mode, when a Watchdog Timer time-out occurs, the TO and PDF bits in the status register will be set high and only the Program Counter and Stack Pointer will be reset. Three methods can be adopted to clear the contents of the Watchdog Timer. The first is a WDTC software reset, which means a certain value except 01010B and 10101B written into the WE4~WE0 bits, the second is using the Watchdog Timer software clear instruction, the third is via a HALT instruction.

There is only one method of using software instruction to clear the Watchdog Timer. That is to use the single “CLR WDT” instruction to clear the WDT.

The maximum time-out period is when the  $2^{15}$  division ratio is selected. As an example, with a 32kHz LIRC oscillator as its source clock, this will give a maximum watchdog period of around 1 second for the  $2^{15}$  division ratio, and a minimum timeout of 8ms for the  $2^8$  division ratio.

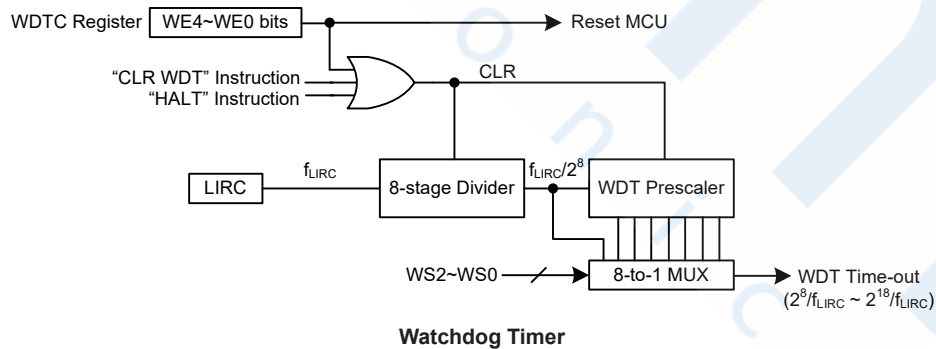

## Reset and Initialisation

A reset function is a fundamental part of any microcontroller ensuring that the device can be set to some predetermined condition irrespective of outside parameters. The most important reset condition is after power is first applied to the microcontroller. In this case, internal circuitry will ensure that the microcontroller, after a short delay, will be in a well-defined state and ready to execute the first program instruction. After this power-on reset, certain important internal registers will be set to defined states before the program commences. One of these registers is the Program Counter, which will be reset to zero forcing the microcontroller to begin program execution from the lowest Program Memory address.

In addition to the power-on reset, another reset exists in the form of a Low Voltage Reset, LVR, where a full reset is implemented in situations where the power supply voltage falls below a certain threshold. Another type of reset is when the Watchdog Timer overflows and resets the microcontroller. All types of reset operations result in different register conditions being setup.

### Reset Functions

There are several ways in which a microcontroller reset can occur through events occurring internally.

#### Power-on Reset

The most fundamental and unavoidable reset is the one that occurs after power is first applied to the microcontroller. As well as ensuring that the Program Memory begins execution from the first memory address, a power-on reset also ensures that certain other registers are preset to known conditions. All the I/O port and port control registers will power up in a high condition ensuring that all pins will be first set to inputs.

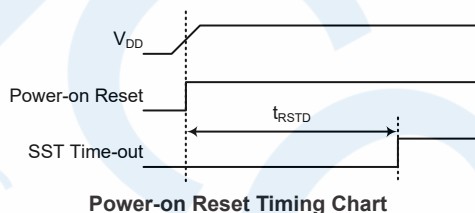

**Power-on Reset Timing Chart**

#### Low Voltage Reset – LVR

The microcontroller contains a low voltage reset circuit in order to monitor the supply voltage of the device and provides an MCU reset should the value fall below a certain predefined level.

If the supply voltage of the device drops to within a range of  $0.9V \sim V_{LVR}$  such as might occur when changing the battery in battery powered applications, the LVR will automatically reset the device internally and the LVRF bit in the RSTFC register will also be set to 1. For a valid LVR signal, a low supply voltage, i.e., a voltage in the range between  $0.9V \sim V_{LVR}$  must exist for a time greater than that specified by  $t_{LVR}$  in the LVR Electrical Characteristics. If the low supply voltage state does not exceed this value, the LVR will ignore the low supply voltage and will not perform a reset function. The actual  $t_{LVR}$  value can be selected by the TLVR1~TLVR0 bits in the TLVRC register. If the LVS7~LVS0 bits are set to 01011010B, the LVR function is enabled with a fixed  $V_{LVR}$  of 2.1V. If the LVS7~LVS0 bits are set to 10100101B, the LVR function is disabled. If the LVS7~LVS0 bits are changed to other values by environmental noise, the LVR will reset the device after a delay time,  $t_{SRESET}$ . When this happens, the LRF bit in the RSTFC register will be set to 1. After power-on the register will have the value of 01011010B. Note that the LVR function will be automatically disabled when the device enters the SLEEP or IDLE mode.

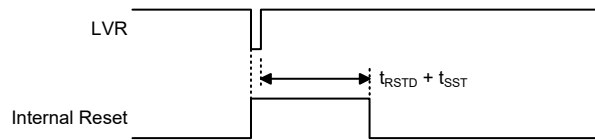

**Low Voltage Reset Timing Chart**
**• LVRC Register**

Bit	7	6	5	4	3	2	1	0
Name	LVS7	LVS6	LVS5	LVS4	LVS3	LVS2	LVS1	LVS0
R/W	R/W	R/W	R/W	R/W	R/W	R/W	R/W	R/W
POR	0	1	0	1	1	0	1	0

Bit 7~0 **LVS7~LVS0**: LVR Voltage Select control

01011010: 2.1V

10100101: LVR disable

Other value: Generates MCU reset – register is reset to POR value

When an actual low voltage condition as specified above occurs, an MCU reset will be generated. The reset operation will be activated after the low voltage condition keeps more than a  $t_{LVR}$  time. In this situation the register contents will remain the same after such a reset occurs.

Any register value, other than 01011010B and 10100101B, will also result in the generation of an MCU reset. The reset operation will be activated after a delay time,  $t_{SRESET}$ . However in this situation the register contents will be reset to the POR value.

**• TLVRC Register**

Bit	7	6	5	4	3	2	1	0
Name	—	—	—	—	—	—	TLVR1	TLVR0
R/W	—	—	—	—	—	—	R/W	R/W
POR	—	—	—	—	—	—	0	1

Bit 7~2 Unimplemented, read as “0”

Bit 1~0 **TLVR1~TLVR0**: Minimum low voltage width to reset time ( $t_{LVR}$ )

00:  $(7\sim 8) \times t_{LIRC}$

01:  $(31\sim 32) \times t_{LIRC}$

10:  $(63\sim 64) \times t_{LIRC}$

11:  $(127\sim 128) \times t_{LIRC}$

**• RSTFC Register**

Bit	7	6	5	4	3	2	1	0
Name	—	—	—	—	—	LVRF	LRF	WRF
R/W	—	—	—	—	—	R/W	R/W	R/W
POR	—	—	—	—	—	x	0	0

“x”: unknown

Bit 7~3 Unimplemented, read as “0”

Bit 2 **LVRF**: LVR function reset flag

0: Not occurred

1: Occurred

This bit is set to 1 when an actual Low Voltage Reset situation condition occurs. This bit can only be cleared to 0 by the application program.

Bit 1 **LRF**: LVR control register software reset flag

0: Not occurred

1: Occurred



This bit is set to 1 if the LVRC register containing any undefined LVR voltage register values. This in effect acts like a software reset function. This bit can only be cleared to 0 by the application program.

Bit 0 **WRF**: WDT control register software reset flag  
 Refer to the Watchdog Timer Control Register section.

**Watchdog Time-out Reset during Normal Operation**

When the Watchdog time-out Reset during normal operation in the FAST or SLOW mode occurs, the Watchdog time-out flag TO will be set to “1”.

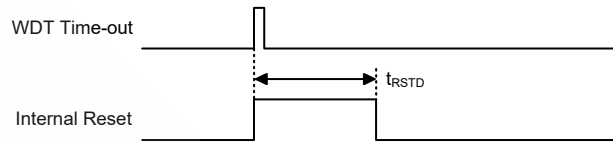

**WDT Time-out Reset during Normal Operation Timing Chart**

**Watchdog Time-out Reset during SLEEP or IDLE Mode**

The Watchdog time-out Reset during SLEEP or IDLE Mode is a little different from other kinds of reset. Most of the conditions remain unchanged except that the Program Counter and the Stack Pointer will be cleared to “0” and the TO and PDF flags will be set to “1”. Refer to the System Start Up Time Characteristics for  $t_{SST}$  details.

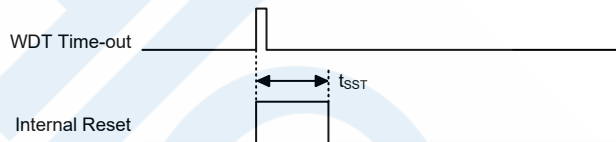

**WDT Time-out Reset during SLEEP or IDLE Timing Chart**

**Reset Initial Conditions**

The different types of reset described affect the reset flags in different ways. These flags, known as PDF and TO are located in the status register and are controlled by various microcontroller operations, such as the SLEEP or IDLE Mode function or Watchdog Timer. The reset flags are shown in the table:

TO	PDF	Reset Conditions
0	0	Power-on reset
u	u	LVR reset during FAST or SLOW Mode operation
1	u	WDT time-out reset during FAST or SLOW Mode operation
1	1	WDT time-out reset during IDLE or SLEEP Mode operation

“u”: unchanged

The following table indicates the way in which the various components of the microcontroller are affected after a power-on reset occurs.

Item	Condition After Reset
Program Counter	Reset to zero
Interrupts	All interrupts will be disabled
WDT, Time Bases	Cleared after reset, WDT begins counting
Timer Module	Timer Module will be turned off
Input/Output Ports	I/O ports will be setup as inputs
Stack Pointer	Stack Pointer will point to the top of the stack

The different kinds of resets all affect the internal registers of the microcontroller in different ways. To ensure reliable continuation of normal program execution after a reset occurs, it is important to know what condition the microcontroller is in after a particular reset occurs. The following table describes how each type of reset affects each of the microcontroller internal registers.

Register Name	Power-On Reset	WDT Time-out (Normal Operation)	WDT Time-out (IDLE/SLEEP)
IAR0	x x x x x x x x	u u u u u u u u	u u u u u u u u
MP0	x x x x x x x x	u u u u u u u u	u u u u u u u u
IAR1	x x x x x x x x	u u u u u u u u	u u u u u u u u
MP1	x x x x x x x x	u u u u u u u u	u u u u u u u u
ACC	x x x x x x x x	u u u u u u u u	u u u u u u u u
PCL	0 0 0 0 0 0 0 0	0 0 0 0 0 0 0 0	0 0 0 0 0 0 0 0
TBLP	x x x x x x x x	u u u u u u u u	u u u u u u u u
TBLH	- x x x x x x x	- u u u u u u u	- u u u u u u u
STATUS	-- 0 0 x x x x	-- 1 u u u u u	-- 1 1 u u u u
RSTFC	- - - - - x 0 0	- - - - - u u u u	- - - - - u u u u
SADC0	0 0 0 0 0 0 0 0	0 0 0 0 0 0 0 0	u u u u u u u u
SADC1	0 0 0 0 0 0 0 0	0 0 0 0 0 0 0 0	u u u u u u u u
SADOH	x x x x x x x x	x x x x x x x x	u u u u u u u u (ADRF5=0)
			- - - - u u u u (ADRF5=1)
SADOL	x x x x - - - -	x x x x - - - -	u u u u - - - - (ADRF5=0)
			u u u u u u u u (ADRF5=1)
PA	1 1 1 1 1 1 1 1	1 1 1 1 1 1 1 1	u u u u u u u u
PAC	1 1 1 1 1 1 1 1	1 1 1 1 1 1 1 1	u u u u u u u u
PAPU	0 0 0 0 0 0 0 0	0 0 0 0 0 0 0 0	u u u u u u u u
PAWU	0 0 0 0 0 0 0 0	0 0 0 0 0 0 0 0	u u u u u u u u
PB	- 1 1 1 1 1 1 1 1	- 1 1 1 1 1 1 1 1	- u u u u u u u
PBC	- 1 1 1 1 1 1 1 1	- 1 1 1 1 1 1 1 1	- u u u u u u u
PBPU	- 0 0 0 0 0 0 0 0	- 0 0 0 0 0 0 0 0	- u u u u u u u
SCC	0 0 0 - - - 0 0	0 0 0 - - - 0 0	u u u - - - u u
HIRCC	- - - - - - 0 1	- - - - - - 0 1	- - - - - - u u
TB0C	0 - - - - 0 0 0	0 - - - - 0 0 0	u - - - - u u u
TB1C	0 - - - - 0 0 0	0 - - - - 0 0 0	u - - - - u u u
USR	0 0 0 0 1 0 1 1	0 0 0 0 1 0 1 1	u u u u u u u u
UCR1	0 0 0 0 0 0 x 0	0 0 0 0 0 0 x 0	u u u u u u u u
UCR2	0 0 0 0 0 0 0 0	0 0 0 0 0 0 0 0	u u u u u u u u
UCR3	- - - - - - - 0	- - - - - - - 0	- - - - - - u
TXR_RXR	x x x x x x x x	x x x x x x x x	u u u u u u u u
BRG	x x x x x x x x	x x x x x x x x	u u u u u u u u
CTMC0	0 0 0 0 0 0 0 0	0 0 0 0 0 0 0 0	u u u u u u u u
CTMC1	0 0 0 0 0 0 0 0	0 0 0 0 0 0 0 0	u u u u u u u u
CTMDL	0 0 0 0 0 0 0 0	0 0 0 0 0 0 0 0	u u u u u u u u

Register Name	Power-On Reset	WDT Time-out (Normal Operation)	WDT Time-out (IDLE/SLEEP)
CTMDH	---- --00	---- --00	---- --uu
CTMAL	0000 0000	0000 0000	uuuu uuuu
CTMAH	---- --00	---- --00	---- --uu
INTC0	-000 0000	-000 0000	-uuu uuuu
INTC1	-000 -000	-000 -000	-uuu -uuu
MFI	--00 --00	--00 --00	--uu --uu
WDTC	0101 0011	0101 0011	uuuu uuuu
INTEG	---- --00	---- --00	---- --uu
LVRC	0101 1010	0101 1010	uuuu uuuu
TLVRC	---- --01	---- --01	---- --uu
DA0L	1000 0010	1000 0010	uuuu uuuu
DA0H	--00 0000	--00 0000	--uu uuuu
DA1L	0000 0000	0000 0000	uuuu uuuu
DA1H	---- 1000	---- 1000	---- uuuu
DAOPC	110- ---0	110- ---0	uuu- ---u
OPVOS	0-10 0000	0-10 0000	u-uu uuuu
PAS0	--00 0000	--00 0000	--uu uuuu
PAS1	0000 0000	0000 0000	uuuu uuuu
PBS0	0000 0000	0000 0000	uuuu uuuu
PBS1	---- 0000	---- 0000	---- uuuu
PSCR	---- --00	---- --00	---- --uu
IFS	---- --00	---- --00	---- --uu
ECR	0000 0000	0000 0000	uuuu uuuu
EAR	---0 0000	---0 0000	---u uuuu
ED0L	0000 0000	0000 0000	uuuu uuuu
ED0H	-000 0000	-000 0000	-uuu uuuu
ED1L	0000 0000	0000 0000	uuuu uuuu
ED1H	-000 0000	-000 0000	-uuu uuuu
ED2L	0000 0000	0000 0000	uuuu uuuu
ED2H	-000 0000	-000 0000	-uuu uuuu
ED3L	0000 0000	0000 0000	uuuu uuuu
ED3H	-000 0000	-000 0000	-uuu uuuu

Note: "u" stands for unchanged  
 "x" stands for unknown  
 "-" stands for unimplemented

## Input/Output Ports

Holtek microcontrollers offer considerable flexibility on their I/O ports. With the input or output designation of every pin fully under user program control, pull-high selections for all ports and wake-up selections on certain pins, the user is provided with an I/O structure to meet the needs of a wide range of application possibilities.

The device provides bidirectional input/output lines labeled with port names PA~PB. These I/O ports are mapped to the RAM Data Memory with specific addresses as shown in the Special Purpose Data Memory table. All of these I/O ports can be used for input and output operations. For input operation, these ports are non-latching, which means the inputs must be ready at the T2 rising edge of instruction “MOV A, [m]”, where m denotes the port address. For output operation, all the data is latched and remains unchanged until the output latch is rewritten.

Register Name	Bit							
	7	6	5	4	3	2	1	0
PA	PA7	PA6	PA5	PA4	PA3	PA2	PA1	PA0
PAC	PAC7	PAC6	PAC5	PAC4	PAC3	PAC2	PAC1	PAC0
PAPU	PAPU7	PAPU6	PAPU5	PAPU4	PAPU3	PAPU2	PAPU1	PAPU0
PAWU	PAWU7	PAWU6	PAWU5	PAWU4	PAWU3	PAWU2	PAWU1	PAWU0
PB	—	PB6	PB5	PB4	PB3	PB2	PB1	PB0
PBC	—	PBC6	PBC5	PBC4	PBC3	PBC2	PBC1	PBC0
PBPU	—	PBPU6	PBPU5	PBPU4	PBPU3	PBPU2	PBPU1	PBPU0

“—”: Unimplemented, read as “0”

### I/O Logic Function Register List

#### Pull-high Resistors

Many product applications require pull-high resistors for their switch inputs usually requiring the use of an external resistor. To eliminate the need for these external resistors, all I/O pins, when configured as a digital input have the capability of being connected to an internal pull-high resistor. These pull-high resistors are selected using registers, namely PAPU~PBPU, and are implemented using weak PMOS transistors.

Note that the pull-high resistor can be controlled by the relevant pull-high control register only when the pin-shared functional pin is selected as a digital input or NMOS output. Otherwise, the pull-high resistors cannot be enabled.

#### • PxPU Register

Bit	7	6	5	4	3	2	1	0
Name	PxPU7	PxPU6	PxPU5	PxPU4	PxPU3	PxPU2	PxPU1	PxPU0
R/W	R/W	R/W	R/W	R/W	R/W	R/W	R/W	R/W
POR	0	0	0	0	0	0	0	0

**PxPUn:** I/O Port x Pin pull-high function control

0: Disable

1: Enable

The PxPUn bit is used to control the pin pull-high function. Here the “x” can be A, B. However, the actual available bits for each I/O Port may be different.

## Port A Wake-up

The HALT instruction forces the microcontroller into the SLEEP or IDLE Mode which preserves power, a feature that is important for battery and other low-power applications. Various methods exist to wake up the microcontroller, one of which is to change the logic condition on one of the Port A pins from high to low. This function is especially suitable for applications that can be woken up via external switches. Each pin on Port A can be selected individually to have this wake-up feature using the PAWU register.

Note that the wake-up function can be controlled by the wake-up control register only when the pin is selected as a general purpose input and the MCU enters the IDLE or SLEEP mode.

### • PAWU Register

Bit	7	6	5	4	3	2	1	0
Name	PAWU7	PAWU6	PAWU5	PAWU4	PAWU3	PAWU2	PAWU1	PAWU0
R/W	R/W	R/W	R/W	R/W	R/W	R/W	R/W	R/W
POR	0	0	0	0	0	0	0	0

Bit 7~0 **PAWU7~PAWU0**: PA7~PA0 wake-up function control  
 0: Disable  
 1: Enable

## I/O Port Control Registers

Each I/O port has its own control register known as PAC~PBC, to control the input/output configuration. With this control register, each CMOS output or input can be reconfigured dynamically under software control. Each pin of the I/O ports is directly mapped to a bit in its associated port control register. For the I/O pin to function as an input, the corresponding bit of the control register must be written as a “1”. This will then allow the logic state of the input pin to be directly read by instructions. When the corresponding bit of the control register is written as a “0”, the I/O pin will be setup as a CMOS output. If the pin is currently setup as an output, instructions can still be used to read the output register. However, it should be noted that the program will in fact only read the status of the output data latch and not the actual logic status of the output pin.

### • PxC Register

Bit	7	6	5	4	3	2	1	0
Name	PxC7	PxC6	PxC5	PxC4	PxC3	PxC2	PxC1	PxC0
R/W	R/W	R/W	R/W	R/W	R/W	R/W	R/W	R/W
POR	1	1	1	1	1	1	1	1

**PxCn**: I/O Port x Pin type selection  
 0: Output  
 1: Input

The PxCn bit is used to control the pin type selection. Here the “x” can be A, B. However, the actual available bits for each I/O Port may be different.

## Pin-shared Functions

The flexibility of the microcontroller range is greatly enhanced by the use of pins that have more than one function. Limited numbers of pins can force serious design constraints on designers but by supplying pins with multi-functions, many of these difficulties can be overcome. For these pins, the desired function of the multi-function I/O pins is selected by a series of registers via the application program control.

### Pin-shared Function Selection Registers

The limited number of supplied pins in a package can impose restrictions on the amount of functions a certain device can contain. However by allowing the same pins to share several different functions and providing a means of function selection, a wide range of different functions can be incorporated into even relatively small package sizes. The device includes Port “x” Output Function Selection register “n”, labeled as P<sub>x</sub>S<sub>n</sub>, and Input Function Selection register, labeled as IFS, which can select the desired functions of the multi-function pin-shared pins.

The most important point to note is to make sure that the desired pin-shared function is properly selected and also deselected. For most pin-shared functions, to select the desired pin-shared function, the pin-shared function should first be correctly selected using the corresponding pin-shared control register. After that the corresponding peripheral functional setting should be configured and then the peripheral function can be enabled. However, a special point must be noted for some digital input pins, such as INT, CTCK, etc., which share the same pin-shared control configuration with their corresponding general purpose I/O functions when setting the relevant pin-shared control bit fields. To select these pin functions, in addition to the necessary pin-shared control and peripheral functional setup aforementioned, they must also be setup as input by setting the corresponding bit in the I/O port control register. To correctly deselect the pin-shared function, the peripheral function should first be disabled and then the corresponding pin-shared function control register can be modified to select other pin-shared functions.

Register Name	Bit							
	7	6	5	4	3	2	1	0
PAS0	—	—	PAS05	PAS04	PAS03	PAS02	PAS01	PAS00
PAS1	PAS17	PAS16	PAS15	PAS14	PAS13	PAS12	PAS11	PAS10
PBS0	PBS07	PBS06	PBS05	PBS04	PBS03	PBS02	PBS01	PBS00
PBS1	—	—	—	—	PBS13	PBS12	PBS11	PBS10
IFS	—	—	—	—	—	—	IFS1	IFS0

Pin-shared Function Selection Register List

#### • PAS0 Register

Bit	7	6	5	4	3	2	1	0
Name	—	—	PAS05	PAS04	PAS03	PAS02	PAS01	PAS00
R/W	—	—	R/W	R/W	R/W	R/W	R/W	R/W
POR	—	—	0	0	0	0	0	0

- Bit 7~6 Unimplemented, read as “0”
- Bit 5~4 **PAS05~PAS04:** PA2 Pin-Shared function selection  
 00: PA2  
 01: PA2  
 10: PA2  
 11: RX/TX
- Bit 3~2 **PAS03~PAS02:** PA1 Pin-Shared function selection  
 00: PA1  
 01: PA1  
 10: AN6  
 11: OPA2P
- Bit 1~0 **PAS01~PAS00:** PA0 Pin-Shared function selection  
 00: PA0  
 01: PA0  
 10: PA0  
 11: TX

• PAS1 Register

Bit	7	6	5	4	3	2	1	0
Name	PAS17	PAS16	PAS15	PAS14	PAS13	PAS12	PAS11	PAS10
R/W	R/W	R/W	R/W	R/W	R/W	R/W	R/W	R/W
POR	0	0	0	0	0	0	0	0

Bit 7~6 **PAS17~PAS16:** PA7 Pin-Shared function selection

00: PA7  
01: PA7  
10: TX  
11: CTP

Bit 5~4 **PAS15~PAS14:** PA6 Pin-Shared function selection

00: PA6  
01: PA6  
10: TX  
11: OPA1P

Bit 3~2 **PAS13~PAS12:** PA5 Pin-Shared function selection

00: PA5  
01: PA5  
10: RX/TX  
11: OPA0P

Bit 1~0 **PAS11~PAS10:** PA4 Pin-Shared function selection

00: PA4  
01: PA4  
10: PA4  
11: CTPB

• PBS0 Register

Bit	7	6	5	4	3	2	1	0
Name	PBS07	PBS06	PBS05	PBS04	PBS03	PBS02	PBS01	PBS00
R/W	R/W	R/W	R/W	R/W	R/W	R/W	R/W	R/W
POR	0	0	0	0	0	0	0	0

Bit 7~6 **PBS07~PBS06:** PB3 Pin-Shared function selection

00: PB3  
01: PB3  
10: PB3  
11: AN3

Bit 5~4 **PBS05~PBS04:** PB2 Pin-Shared function selection

00: PB2  
01: PB2  
10: PB2  
11: AN2

Bit 3~2 **PBS03~PBS02:** PB1 Pin-Shared function selection

00: PB1  
01: PB1  
10: VREF  
11: AN1

Bit 1~0 **PBS01~PBS00:** PB0 Pin-Shared function selection

00: PB0  
01: PB0  
10: PB0  
11: AN0

• **PBS1 Register**

Bit	7	6	5	4	3	2	1	0
Name	—	—	—	—	PBS13	PBS12	PBS11	PBS10
R/W	—	—	—	—	R/W	R/W	R/W	R/W
POR	—	—	—	—	0	0	0	0

Bit 7~4 Unimplemented, read as “0”

Bit 3~2 **PBS13~PBS12**: PB5 Pin-Shared function selection  
 00: PB5/CTCK  
 01: PB5/CTCK  
 10: RX/TX  
 11: AN5

Bit 1~0 **PBS11~PBS10**: PB4 Pin-Shared function selection  
 00: PB4  
 01: PB4  
 10: PB4  
 11: AN4

• **IFS Register**

Bit	7	6	5	4	3	2	1	0
Name	—	—	—	—	—	—	IFS1	IFS0
R/W	—	—	—	—	—	—	R/W	R/W
POR	—	—	—	—	—	—	0	0

Bit 7~2 Unimplemented, read as “0”

Bit 1~0 **IFS1~IFS0**: RX/TX input source pin selection  
 00: PA5  
 01: PA5  
 10: PA2  
 11: PB5

**I/O Pin Structures**

The accompanying diagram illustrates the internal structures of the I/O logic function. As the exact logical construction of the I/O pin will differ from this diagram, it is supplied as a guide only to assist with the functional understanding of the logic function I/O pins. The wide range of pin-shared structures does not permit all types to be shown.



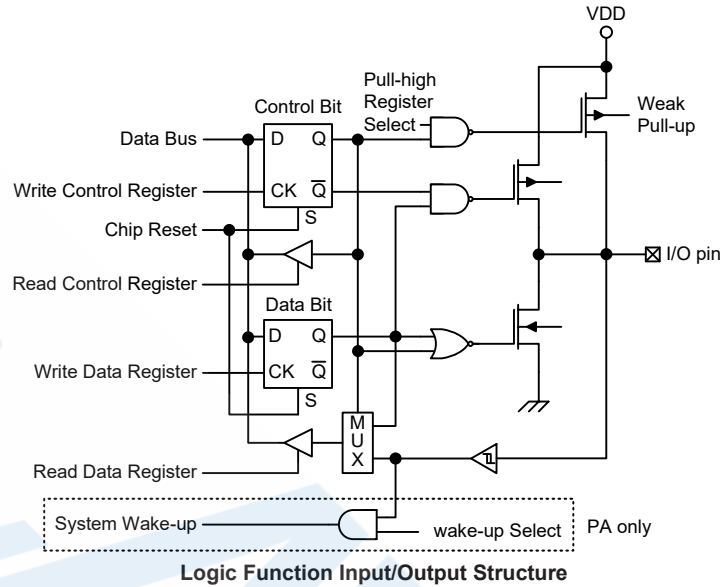

### Programming Considerations

Within the user program, one of the first things to consider is port initialisation. After a reset, all of the I/O data and port control registers will be set high. This means that all I/O pins will default to an input state, the level of which depends on the other connected circuitry and whether pull-high selections have been chosen. If the port control registers are then programmed to setup some pins as outputs, these output pins will have an initial high output value unless the associated port data registers are first programmed. Selecting which pins are inputs and which are outputs can be achieved byte-wide by loading the correct values into the appropriate port control register or by programming individual bits in the port control register using the “SET [m].i” and “CLR [m].i” instructions. Note that when using these bit control instructions, a read-modify-write operation takes place. The microcontroller must first read in the data on the entire port, modify it to the required new bit values and then rewrite this data back to the output ports.

Port A has the additional capability of providing wake-up function. When the device is in the SLEEP or IDLE Mode, various methods are available to wake the device up. One of these is a high to low transition of any of the Port A pins. Single or multiple pins on Port A can be setup to have this function.

## Timer Modules – TM

One of the most fundamental functions in any microcontroller device is the ability to control and measure time. To implement time related functions, the device includes a Timer Module, abbreviated to the name TM. The TM is a multi-purpose timing units and serve to provide operations such as Timer/Counter, Compare Match Output and being the functional unit for the generation of PWM signals. The TM has two individual interrupts. The addition of input and output pins for the TM ensures that users are provided with timing units with a wide and flexible range of features.

The brief features of the Compact type TM are described here with more detailed information provided in the individual Compact type TM section.

### Introduction

The device contains a Compact Type TM. The main features of CTM are summarised in the accompanying table.

Function	CTM
Timer/Counter	√
Compare Match Output	√
PWM Output	√
PWM Alignment	Edge
PWM Adjustment Period & Duty	Duty or Period

**TM Function Summary**

### TM Operation

The Compact type TM offers a diverse range of functions, from simple timing operations to PWM signal generation. The key to understanding how the TM operates is to see it in terms of a free running counter whose value is then compared with the value of pre-programmed internal comparators. When the free running counter has the same value as the pre-programmed comparator, known as a compare match situation, a TM interrupt signal will be generated which can clear the counter and perhaps also change the condition of the TM output pin. The internal TM counter is driven by a user selectable clock source, which can be an internal clock or an external pin.

### TM Clock Source

The clock source which drives the main counter in TM can originate from various sources. The selection of the required clock source is implemented using the CTCK2~CTCK0 bits in the CTM control register. The clock source can be a ratio of the system clock,  $f_{SYS}$ , or the internal high clock,  $f_H$ , the  $f_{SUB}$  clock source or the external CTCK pin. The CTCK pin clock source is used to allow an external signal to drive the TM as an external clock source or for event counting.

### TM Interrupts

The Compact type TM has two internal interrupts, one for each of the internal comparator A or comparator P, which generate a TM interrupt when a compare match condition occurs. When a TM interrupt is generated it can be used to clear the counter and also to change the state of the TM output pin.

### TM External Pins

The Compact type TM has one input pin with the label CTCK. The CTM input pin, CTCK, is essentially a clock source for the CTM and is selected using the CTCK2~CTCK0 bits in the CTMCO register. This external TM input pin allows an external clock source to drive the internal TM. The CTCK input pin can be chosen to have either a rising or falling active edge.

The CTM has two output pins with the label CTP and CTPB. When the TM is in the Compare Match Output Mode, the CTPB pin can be controlled by the TM to switch to a high or low level or to toggle when a compare match situation occurs. The CTPB pin output is the inverted signal of the CTP. The external output pins are also the pins where the TM generates the PWM output waveform.

As the TM input and output pins are pin-shared with other functions, the TM input and output functions must first be selected using relevant pin-shared function selection bits described in the Pin-shared Function section.

CTM	
Input	Output
CTCK	CTP, CTPB

TM External Pins

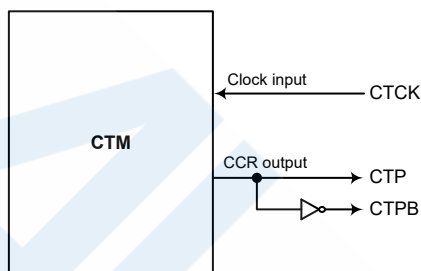

CTM Function Pin Block Diagram

### Programming Considerations

The TM Counter Registers and the Compare CCRA registers, all have a low and high byte structure. The high bytes can be directly accessed, but as the low bytes can only be accessed via an internal 8-bit buffer, reading or writing to these register pairs must be carried out in a specific way. The important point to note is that data transfer to and from the 8-bit buffer and its related low byte only takes place when a write or read operation to its corresponding high byte is executed.

As the CCRA registers are implemented in the way shown in the following diagram and accessing the register pair is carried out in a specific way as described above, it is recommended to use the “MOV” instruction to access the CCRA low byte register, named CTMAL, using the following access procedures. Accessing the CCRA low byte register without following these access procedures will result in unpredictable values.

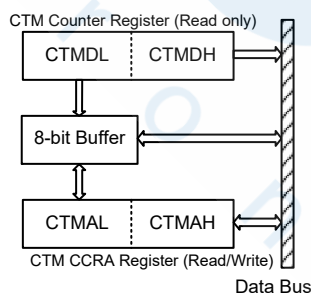

The following steps show the read and write procedures:

- Writing Data to CCRA
  - ♦ Step 1. Write data to Low Byte CTMAL
    - Note that here data is only written to the 8-bit buffer.

- ♦ Step 2. Write data to High Byte CTMAH
  - Here data is written directly to the high byte register and simultaneously data is latched from the 8-bit buffer to the Low Byte registers.
- Reading Data from the Counter Registers and or CCRA
  - ♦ Step 1. Read data from the High Byte CTMDH or CTMAH
    - Here data is read directly from the High Byte registers and simultaneously data is latched from the Low Byte registers into the 8-bit buffer.
  - ♦ Step 2. Read data from the Low Byte CTMDL or CTMAL
    - This step reads data from the 8-bit buffer.

## Compact Type TM – CTM

The Compact Type TM contains three operating modes, which are Compare Match Output, Timer/Event Counter and PWM Output modes. The Compact Type TM can also be controlled with an external input pin and can drive two external output pins.

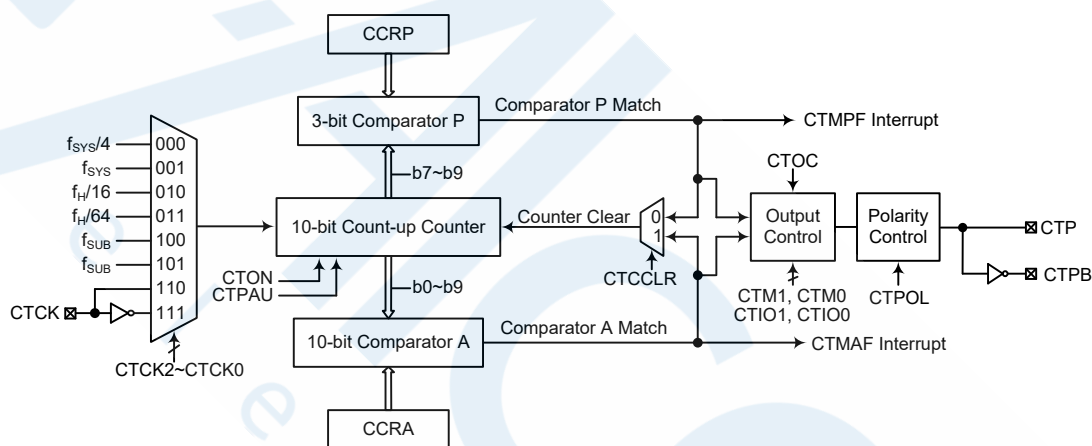

- Note: 1. As the CTM external pins are pin-shared with other functions, so before using the CTM function, the relevant pin-shared function registers must be set properly to enable the CTM pin function. The CTCK pin, if used, must be set as an input by setting the corresponding bits in the port control register.
2. The CTPB is the inverted signal of the CTP.

**10-bit Compact Type TM Block Diagram**

## Compact Type TM Operation

The size of Compact Type TM is 10-bit wide and its core is a 10-bit count-up counter which is driven by a user selectable internal or external clock source. There are also two internal comparators with the names, Comparator A and Comparator P. These comparators will compare the value in the counter with CCRP and CCRA registers. The CCRP comparator is 3 bits wide whose value is compared with the highest 3 bits in the counter while the CCRA is the 10 bits and therefore compares with all counter bits.

The only way of changing the value of the 10-bit counter using the application program, is to clear the counter by changing the CTON bit from low to high. The counter will also be cleared automatically by a counter overflow or a compare match with one of its associated comparators. When these conditions occur, a CTM interrupt signal will also usually be generated. The Compact Type TM can operate in a number of different operational modes, can be driven by different clock sources including an input pin and can also control two output pins. All operating setup conditions are selected using relevant internal registers.

## Compact Type TM Register Description

Overall operation of the Compact Type TM is controlled using a series of registers. A read only register pair exists to store the internal counter 10-bit value, while a read/write register pair exists to store the internal 10-bit CCRA value. The remaining two registers are control registers which setup the different operating and control modes as well as three CCRP bits.

Register Name	Bit							
	7	6	5	4	3	2	1	0
CTMC0	CTPAU	CTCK2	CTCK1	CTCK0	CTON	CTRP2	CTRP1	CTRP0
CTMC1	CTM1	CTM0	CTIO1	CTIO0	CTOC	CTPOL	CTDPX	CTCCLR
CTMDL	D7	D6	D5	D4	D3	D2	D1	D0
CTMDH	—	—	—	—	—	—	D9	D8
CTMAL	D7	D6	D5	D4	D3	D2	D1	D0
CTMAH	—	—	—	—	—	—	D9	D8

10-bit Compact Type TM Register List

### • CTMC0 Register

Bit	7	6	5	4	3	2	1	0
Name	CTPAU	CTCK2	CTCK1	CTCK0	CTON	CTRP2	CTRP1	CTRP0
R/W	R/W	R/W	R/W	R/W	R/W	R/W	R/W	R/W
POR	0	0	0	0	0	0	0	0

Bit 7 **CTPAU**: CTM Counter Pause control

0: Run  
1: Pause

The counter can be paused by setting this bit high. Clearing the bit to zero restores normal counter operation. When in a Pause condition the CTM will remain powered up and continue to consume power. The counter will retain its residual value when this bit changes from low to high and resume counting from this value when the bit changes to a low value again.

Bit 6~4 **CTCK2~CTCK0**: Select CTM Counter clock

000:  $f_{SYS}/4$   
001:  $f_{SYS}$   
010:  $f_H/16$   
011:  $f_H/64$   
100:  $f_{SUB}$   
101:  $f_{SUB}$   
110: CTCK rising edge clock  
111: CTCK falling edge clock

These three bits are used to select the clock source for the CTM. The external pin clock source can be chosen to be active on the rising or falling edge. The clock source  $f_{SYS}$  is the system clock, while  $f_H$  and  $f_{SUB}$  are other internal clocks, the details of which can be found in the oscillator section.

Bit 3 **CTON**: CTM Counter On/Off control

0: Off  
1: On

This bit controls the overall on/off function of the CTM. Setting the bit high enables the counter to run while clearing the bit disables the CTM. Clearing this bit to zero will stop the counter from counting and turn off the CTM which will reduce its power consumption. When the bit changes state from low to high the internal counter value will be reset to zero, however when the bit changes from high to low, the internal counter will retain its residual value until the bit returns high again.

If the CTM is in the Compare Match Output Mode or the PWM Output Mode then the CTM output pin will be reset to its initial condition, as specified by the CTOC bit, when the CTON bit changes from low to high.

Bit 2~0 **CTRP2~CTRP0**: CTM CCRP 3-bit register, compared with the CTM counter bit 9~bit 7  
 Comparator P match period=  
 000: 1024 CTM clocks  
 001: 128 CTM clocks  
 010: 256 CTM clocks  
 011: 384 CTM clocks  
 100: 512 CTM clocks  
 101: 640 CTM clocks  
 110: 768 CTM clocks  
 111: 896 CTM clocks

These three bits are used to setup the value on the internal CCRP 3-bit register, which are then compared with the internal counter's highest three bits. The result of this comparison can be selected to clear the internal counter if the CTCCLR bit is set to zero. Setting the CTCCLR bit to zero ensures that a compare match with the CCRP values will reset the internal counter. As the CCRP bits are only compared with the highest three counter bits, the compare values exist in 128 clock cycle multiples. Clearing all three bits to zero is in effect allowing the counter to overflow at its maximum value.

• **CTMC1 Register**

Bit	7	6	5	4	3	2	1	0
Name	CTM1	CTM0	CTIO1	CTIO0	CTOC	CTPOL	CTDPX	CTCCLR
R/W	R/W	R/W	R/W	R/W	R/W	R/W	R/W	R/W
POR	0	0	0	0	0	0	0	0

Bit 7~6 **CTM1~CTM0**: Select CTM Operating Mode  
 00: Compare Match Output Mode  
 01: Undefined  
 10: PWM Output Mode  
 11: Timer/Counter Mode

These bits setup the required operating mode for the CTM. To ensure reliable operation the CTM should be switched off before any changes are made to the CTM1 and CTM0 bits. In the Timer/Counter Mode, the CTM output pin state is undefined.

Bit 5~4 **CTIO1~CTIO0**: Select CTM external pin function  
 Compare Match Output Mode  
 00: No change  
 01: Output low  
 10: Output high  
 11: Toggle output

PWM Output Mode  
 00: PWM output inactive state  
 01: PWM output active state  
 10: PWM output  
 11: Undefined

Timer/Counter Mode  
 Unused

These two bits are used to determine how the CTM external pin changes state when a certain condition is reached. The function that these bits select depends upon in which mode the CTM is running.

In the Compare Match Output Mode, the CTIO1 and CTIO0 bits determine how the CTM output pin changes state when a compare match occurs from the Comparator A. The CTM output pin can be setup to switch high, switch low or to toggle its present

state when a compare match occurs from the Comparator A. When the bits are both zero, then no change will take place on the output. The initial value of the CTM output pin should be setup using the CTOC bit in the CTMC1 register. Note that the output level requested by the CTIO1 and CTIO0 bits must be different from the initial value setup using the CTOC bit otherwise no change will occur on the CTM output pin when a compare match occurs. After the CTM output pin changes state, it can be reset to its initial level by changing the level of the CTON bit from low to high.

In the PWM Output Mode, the CTIO1 and CTIO0 bits determine how the CTM output pin changes state when a certain compare match condition occurs. The PWM output function is modified by changing these two bits. It is necessary to change the values of the CTIO1 and CTIO0 bits only after the CTM has been switched off. Unpredictable PWM outputs will occur if the CTIO1 and CTIO0 bits are changed when the CTM is running.

Bit 3

**CTOC:** CTP Output control  
Compare Match Output Mode  
0: Initial low  
1: Initial high  
PWM Output Mode  
0: Active low  
1: Active high

This is the output control bit for the CTM output pin. Its operation depends upon whether CTM is being used in the Compare Match Output Mode or in the PWM Output Mode. It has no effect if the CTM is in the Timer/Counter Mode. In the Compare Match Output Mode it determines the logic level of the CTM output pin before a compare match occurs. In the PWM Output Mode it determines if the PWM signal is active high or active low.

Bit 2

**CTPOL:** CTP Output polarity control  
0: Non-invert  
1: Invert

This bit controls the polarity of the CTP output pin. When the bit is set high the CTM output pin will be inverted and not inverted when the bit is zero. It has no effect if the CTM is in the Timer/Counter Mode.

Bit 1

**CTDPX:** CTM PWM duty/period control  
0: CCRP – period; CCRA – duty  
1: CCRP – duty; CCRA – period

This bit determines which of the CCRA and CCRP registers are used for period and duty control of the PWM waveform.

Bit 0

**CTCCLR:** CTM Counter clear condition selection  
0: CTM Comparator P match  
1: CTM Comparator A match

This bit is used to select the method which clears the counter. Remember that the Compact TM contains two comparators, Comparator A and Comparator P, either of which can be selected to clear the internal counter. With the CTCCLR bit set high, the counter will be cleared when a compare match occurs from the Comparator A. When the bit is low, the counter will be cleared when a compare match occurs from the Comparator P or with a counter overflow. A counter overflow clearing method can only be implemented if the CCRP bits are all cleared to zero. The CTCCLR bit is not used in the PWM Output mode.



**• CTMDL Register**

Bit	7	6	5	4	3	2	1	0
Name	D7	D6	D5	D4	D3	D2	D1	D0
R/W	R	R	R	R	R	R	R	R
POR	0	0	0	0	0	0	0	0

Bit 7~0      **D7~D0**: CTM Counter Low Byte Register bit 7 ~ bit 0  
 CTM 10-bit Counter bit 7 ~ bit 0

**• CTMDH Register**

Bit	7	6	5	4	3	2	1	0
Name	—	—	—	—	—	—	D9	D8
R/W	—	—	—	—	—	—	R	R
POR	—	—	—	—	—	—	0	0

Bit 7~2      Unimplemented, read as “0”  
 Bit 1~0      **D9~D8**: CTM Counter High Byte Register bit 1 ~ bit 0  
 CTM 10-bit Counter bit 9 ~ bit 8

**• CTMAL Register**

Bit	7	6	5	4	3	2	1	0
Name	D7	D6	D5	D4	D3	D2	D1	D0
R/W	R/W	R/W	R/W	R/W	R/W	R/W	R/W	R/W
POR	0	0	0	0	0	0	0	0

Bit 7~0      **D7~D0**: CTM CCRA Low Byte Register bit 7 ~ bit 0  
 CTM 10-bit CCRA bit 7 ~ bit 0

**• CTMAH Register**

Bit	7	6	5	4	3	2	1	0
Name	—	—	—	—	—	—	D9	D8
R/W	—	—	—	—	—	—	R/W	R/W
POR	—	—	—	—	—	—	0	0

Bit 7~2      Unimplemented, read as “0”  
 Bit 1~0      **D9~D8**: CTM CCRA High Byte Register bit 1 ~ bit 0  
 CTM 10-bit CCRA bit 9 ~ bit 8



## Compact Type TM Operation Modes

The Compact Type TM can operate in one of three operating modes, Compare Match Output Mode, PWM Output Mode or Timer/Counter Mode. The operating mode is selected using the CTM1 and CTM0 bits in the CTMC1 register.

### Compare Match Output Mode

To select this mode, bits CTM1 and CTM0 in the CTMC1 register, should be set to 00 respectively. In this mode once the counter is enabled and running it can be cleared by three methods. These are a counter overflow, a compare match from Comparator A and a compare match from Comparator P. When the CTCCLR bit is low, there are two ways in which the counter can be cleared. One is when a compare match from Comparator P, the other is when the CCRP bits are all zero which allows the counter to overflow. Here both CTMAF and CTMPF interrupt request flags for Comparator A and Comparator P respectively, will both be generated.

If the CTCCLR bit in the CTMC1 register is high then the counter will be cleared when a compare match occurs from Comparator A. However, here only the CTMAF interrupt request flag will be generated even if the value of the CCRP bits is less than that of the CCRA registers. Therefore when CTCCLR is high no CTMPF interrupt request flag will be generated. If the CCRA bits are all zero, the counter will overflow when it reaches its maximum 10-bit, 3FF Hex, value. However, here the CTMAF interrupt request flag will not be generated.

As the name of the mode suggests, after a comparison is made, the CTM output pin, will change state. The CTM output pin condition however only changes state when a CTMAF interrupt request flag is generated after a compare match occurs from Comparator A. The CTMPF interrupt request flag, generated from a compare match occurs from Comparator P, will have no effect on the CTM output pin. The way in which the CTM output pin changes state are determined by the condition of the CTIO1 and CTIO0 bits in the CTMC1 register. The CTM output pin can be selected using the CTIO1 and CTIO0 bits to go high, to go low or to toggle from its present condition when a compare match occurs from Comparator A. The initial condition of the CTM output pin, which is setup after the CTON bit changes from low to high, is setup using the CTOC bit. Note that if the CTIO1 and CTIO0 bits are zero then no pin change will take place.

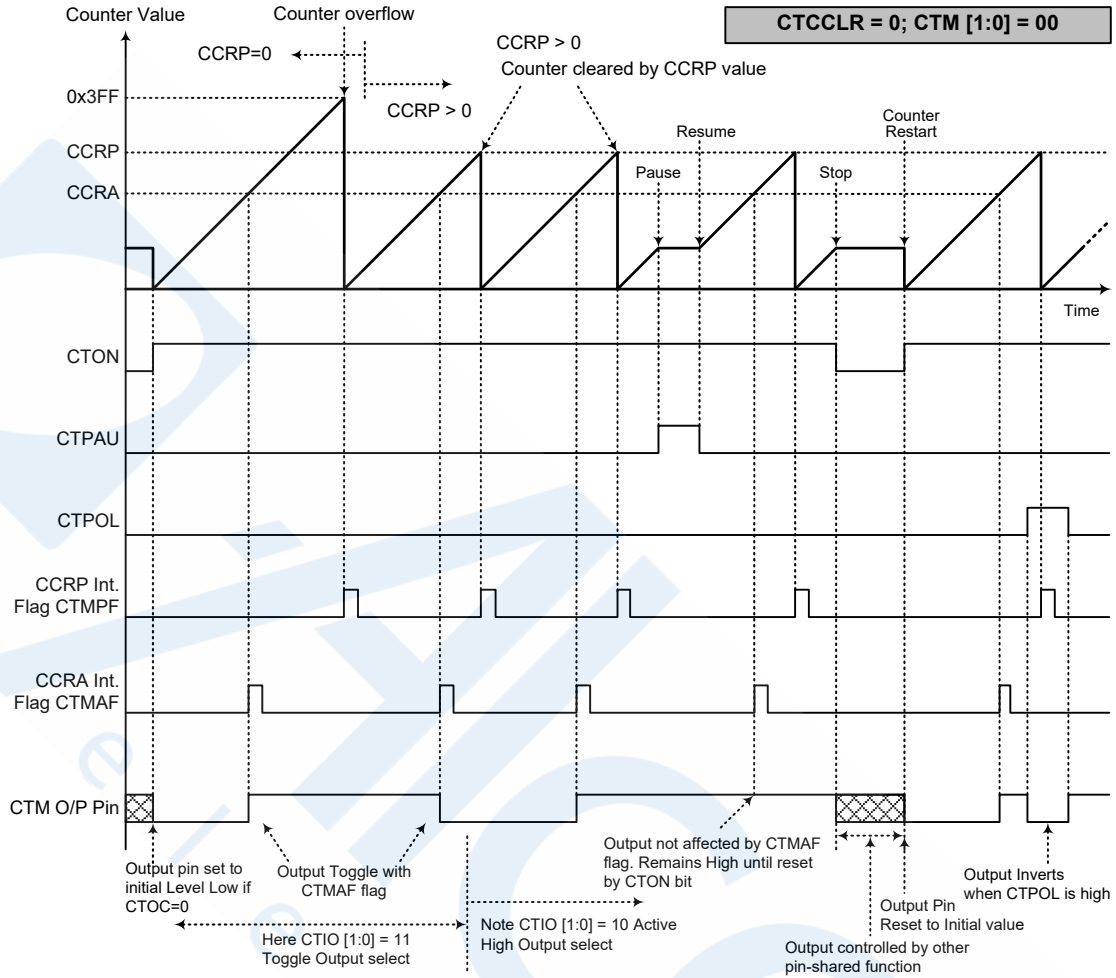

**Compare Match Output Mode – CTCCLR=0**

- Note: 1. With CTCCLR=0, a Comparator P match will clear the counter  
 2. The CTM output pin is controlled only by the CTMAF flag  
 3. The output pin is reset to its initial state by a CTON bit rising edge

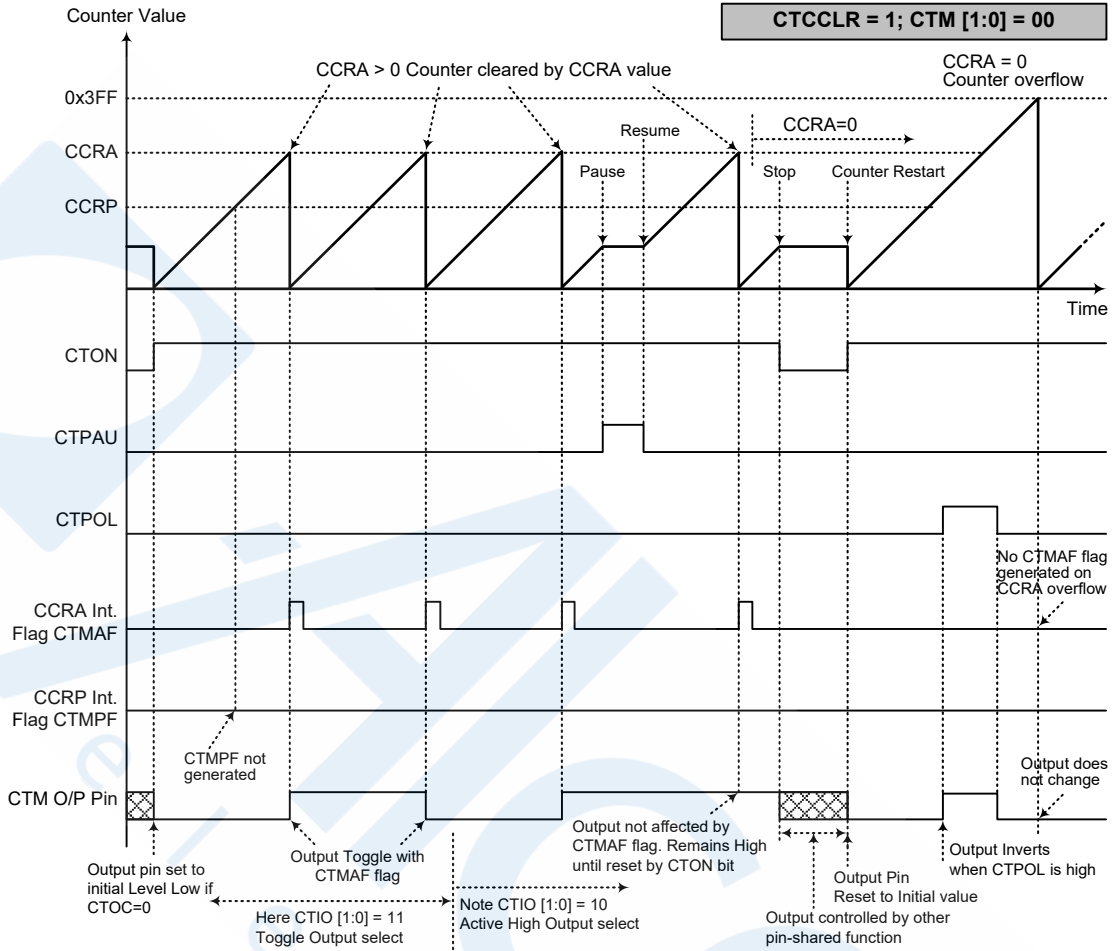

**Compare Match Output Mode – CTCCLR=1**

- Note: 1. With CTCCLR=1, a Comparator A match will clear the counter  
 2. The CTM output pin is controlled only by the CTMAF flag  
 3. The output pin is reset to its initial state by a CTON bit rising edge  
 4. A CTMPF flag is not generated when CTCCLR=1

### Timer/Counter Mode

To select this mode, bits CTM1 and CTM0 in the CTMC1 register should be set to 11 respectively. The Timer/Counter Mode operates in an identical way to the Compare Match Output Mode generating the same interrupt flags. The exception is that in the Timer/Counter Mode the CTM output pin is not used. Therefore the above description and Timing Diagrams for the Compare Match Output Mode can be used to understand its function. As the CTM output pin is not used in this mode, the pin can be used as a normal I/O pin or other pin-shared function.

### PWM Output Mode

To select this mode, bits CTM1 and CTM0 in the CTMC1 register should be set to 10 respectively. The PWM function within the CTM is useful for applications which require functions such as motor control, heating control, illumination control, etc. By providing a signal of fixed frequency but of varying duty cycle on the CTM output pin, a square wave AC waveform can be generated with varying equivalent DC RMS values.

As both the period and duty cycle of the PWM waveform can be controlled, the choice of generated waveform is extremely flexible. In the PWM Output Mode, the CTCCLR bit has no effect on the PWM period. Both of the CCRA and CCRP registers are used to generate the PWM waveform, one register is used to clear the internal counter and thus control the PWM waveform frequency, while the other one is used to control the duty cycle. Which register is used to control either frequency or duty cycle is determined using the CTD PX bit in the CTMC1 register. The PWM waveform frequency and duty cycle can therefore be controlled by the values in the CCRA and CCRP registers.

An interrupt flag, one for each of the CCRA and CCRP, will be generated when a compare match occurs from either Comparator A or Comparator P. The CTOC bit in the CTMC1 register is used to select the required polarity of the PWM waveform while the two CTIO1 and CTIO0 bits are used to enable the PWM output or to force the CTM output pin to a fixed high or low level. The CTPOL bit is used to reverse the polarity of the PWM output waveform.

#### • 10-bit CTM, PWM Output Mode, Edge-aligned Mode, CTD PX=0

CCRP	001b	010b	011b	100b	101b	110b	111b	000b
Period	128	256	384	512	640	768	896	1024
Duty	CCRA							

If  $f_{SYS}=8\text{MHz}$ , CTM clock source is  $f_{SYS}/4$ , CCRP=100b, CCRA=128,

The CTM PWM output frequency= $(f_{SYS}/4)/512=f_{SYS}/2048=4\text{kHz}$ , duty=128/512=25%.

If the Duty value defined by the CCRA register is equal to or greater than the Period value, then the PWM output duty is 100%.

#### • 10-bit CTM, PWM Output Mode, Edge-aligned Mode, CTD PX=1

CCRP	001b	010b	011b	100b	101b	110b	111b	000b
Period	CCRA							
Duty	128	256	384	512	640	768	896	1024

The PWM output period is determined by the CCRA register value together with the CTM clock while the PWM duty cycle is defined by the CCRP register value.

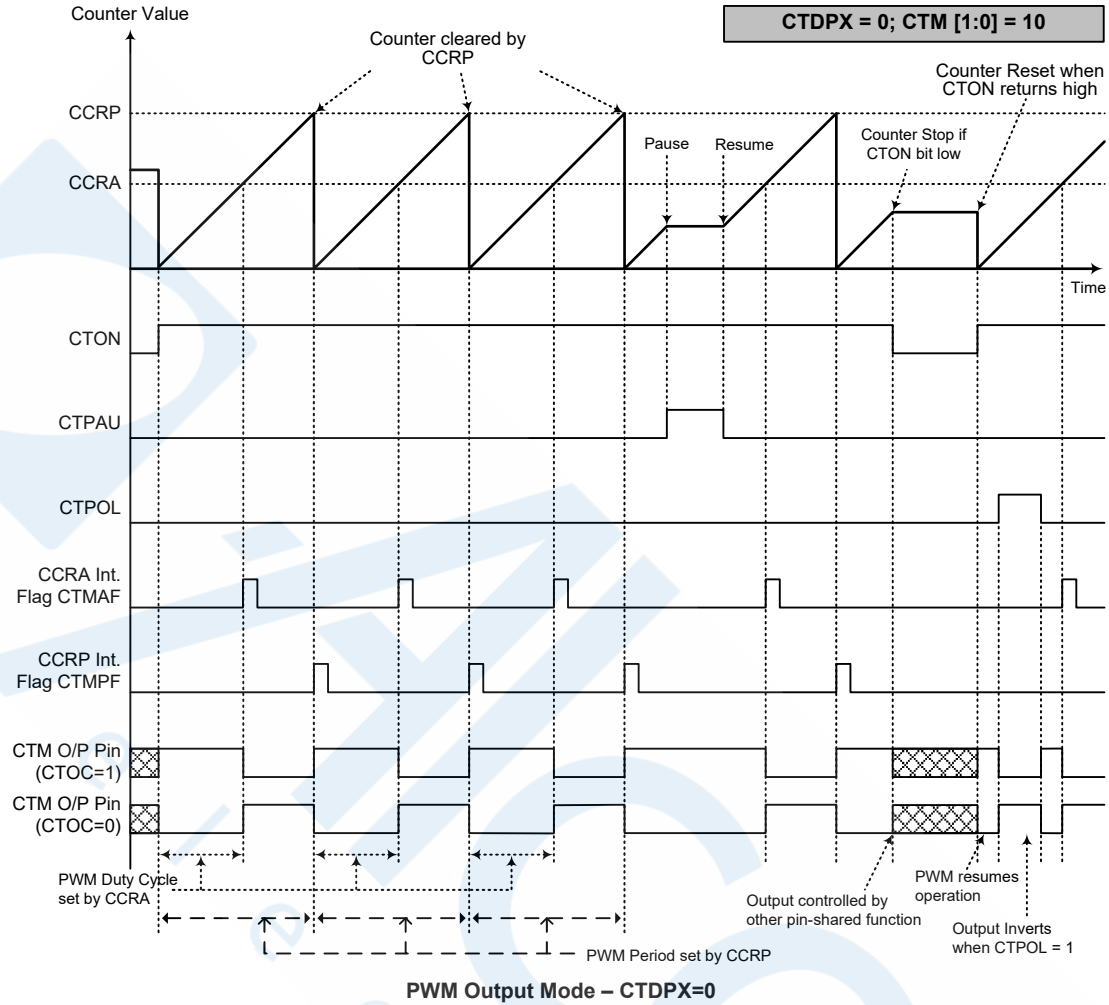

- Note: 1. Here CTDPX=0 – Counter cleared by CCRP  
 2. A counter clear sets the PWM Period  
 3. The internal PWM function continues running even when CTIO[1:0]=00 or 01  
 4. The CTCCLR bit has no influence on PWM operation

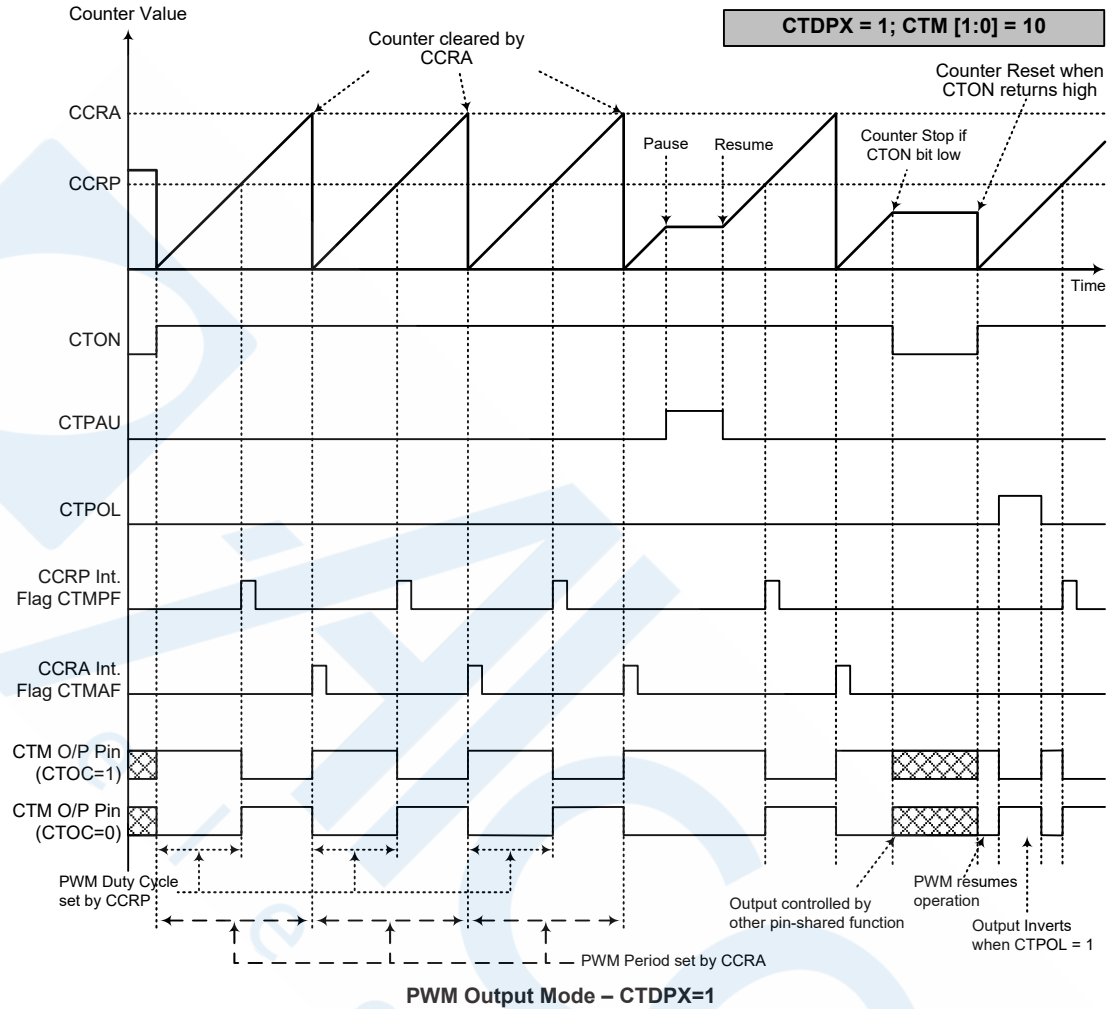

- Note: 1. Here CTDPX=1 – Counter cleared by CCRP  
 2. A counter clear sets the PWM Period  
 3. The internal PWM function continues even when CTIO[1:0]=00 or 01  
 4. The CTCCLR bit has no influence on PWM operation

## Analog to Digital Converter

The need to interface to real world analog signals is a common requirement for many electronic systems. However, to properly process these signals by a microcontroller, they must first be converted into digital signals by A/D converters. By integrating the A/D conversion electronic circuitry into the microcontroller, the need for external components is reduced significantly with the corresponding follow-on benefits of lower costs and reduced component space requirements.

### A/D Converter Overview

This device contains a multi-channel analog to digital converter which can directly interface to external analog signals, such as that from sensors or other control signals and convert these signals directly into a 12-bit digital value. It also can convert the internal analog signals, such as the OPA2 output voltage,  $20 \times A2P$ , and convert these signals directly into a 12-bit digital value. When the external analog signal is to be converted, the corresponding pin-shared control bit should first be properly configured and then the desired external channel input should be selected using the SACS3~SACS0 bits. More detailed information about the A/D input signal is described in the “A/D Converter Control Registers” and “A/D Converter Input Signals” sections respectively.

External Input Channels	Internal Input Signals	A/D Input Select Bits
AN0~AN6	$20 \times A2P$	SAINS2~SAINS0, SACS3~SACS0

The accompanying block diagram shows the overall internal structure of the A/D converter, together with its associated registers.

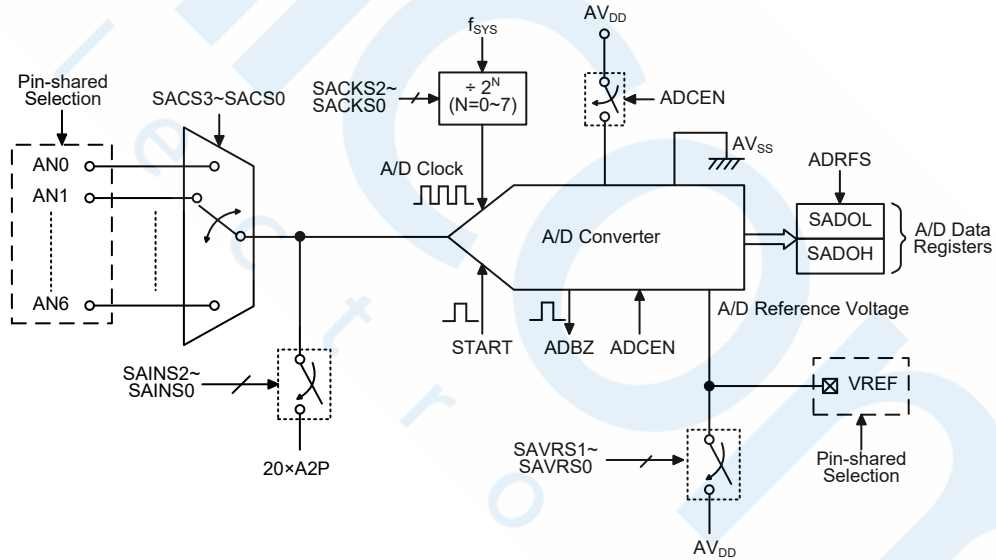

**A/D Converter Structure**

Note:  $20 \times A2P$  is 20 times OPA2 positive input voltage signal. More details can be obtained in the Battery Charge Module section.

### A/D Converter Register Description

Overall operation of the A/D converter is controlled using a series of registers. A read only register pair exists to store the A/D converter data 12-bit value. The remaining two registers are control registers which setup the operating and control function of the A/D converter.

Register Name	Bit							
	7	6	5	4	3	2	1	0
SADOL (ADRF5=0)	D3	D2	D1	D0	—	—	—	—
SADOL (ADRF5=1)	D7	D6	D5	D4	D3	D2	D1	D0
SADOH (ADRF5=0)	D11	D10	D9	D8	D7	D6	D5	D4
SADOH (ADRF5=1)	—	—	—	—	D11	D10	D9	D8
SADC0	START	ADBZ	ADCEN	ADRF5	SACS3	SACS2	SACS1	SACS0
SADC1	SAINS2	SAINS1	SAINS0	SAVRS1	SAVRS0	SACKS2	SACKS1	SACKS0

**A/D Converter Register List**

### A/D Converter Data Registers – SADOL, SADOH

As the device contains an internal 12-bit A/D converter, it requires two data registers to store the converted value. These are a high byte register, known as SADOH, and a low byte register, known as SADOL. After the conversion process takes place, these registers can be directly read by the microcontroller to obtain the digitised conversion value. As only 12 bits of the 16-bit register space is utilised, the format in which the data is stored is controlled by the ADRFS bit in the SADC0 register as shown in the accompanying table. D0~D11 are the A/D conversion result data bits. Any unused bits will be read as zero. Note that the A/D converter data register contents will be unchanged if the A/D converter is disabled.

ADRF5	SADOH								SADOL							
	7	6	5	4	3	2	1	0	7	6	5	4	3	2	1	0
0	D11	D10	D9	D8	D7	D6	D5	D4	D3	D2	D1	D0	0	0	0	0
1	0	0	0	0	D11	D10	D9	D8	D7	D6	D5	D4	D3	D2	D1	D0

**A/D Data Registers**

### A/D Converter Control Registers – SADC0, SADC1

To control the function and operation of the A/D converter, several control registers known as SADC0 and SADC1 are provided. These 8-bit registers define functions such as the selection of which analog channel is connected to the internal A/D converter, the digitised data format, the A/D clock source as well as controlling the start function and monitoring the A/D converter busy status. As the device contains only one actual analog to digital converter hardware circuit, each of the external or internal analog signal inputs must be routed to the converter. The SACS3~SACS0 bits in the SADC0 register are used to determine which external channel input is selected to be converted. The SAINS2~SAINS0 bits in the SADC1 register are used to determine that the analog signal to be converted comes from the internal analog signal or external analog channel input.

The relevant pin-shared function selection bits determine which pins on I/O Ports are used as analog inputs for the A/D converter input and which pins are not to be used as the A/D converter input. When the pin is selected to be an A/D input, its original function whether it is an I/O or other pin-shared function will be removed. In addition, any internal pull-high resistor connected to the pin will be automatically removed if the pin is selected to be an A/D converter input.



• SADC0 Register

Bit	7	6	5	4	3	2	1	0
Name	START	ADBZ	ADCEN	ADRF5	SACS3	SACS2	SACS1	SACS0
R/W	R/W	R	R/W	R/W	R/W	R/W	R/W	R/W
POR	0	0	0	0	0	0	0	0

- Bit 7 **START**: Start the A/D conversion  
0→1→0: Start  
This bit is used to initiate an A/D conversion process. The bit is normally low but if set high and then cleared low again, the A/D converter will initiate a conversion process.
- Bit 6 **ADBZ**: A/D converter busy flag  
0: No A/D conversion is in progress  
1: A/D conversion is in progress  
This read only flag is used to indicate whether the A/D conversion is in progress or not. When the START bit is set from low to high and then to low again, the ADBZ flag will be set to 1 to indicate that the A/D conversion is initiated. The ADBZ flag will be cleared to 0 after the A/D conversion is complete.
- Bit 5 **ADCEN**: A/D converter function enable control  
0: Disable  
1: Enable  
This bit controls the A/D internal function. This bit should be set to one to enable the A/D converter. If the bit is set low, then the A/D converter will be switched off reducing the device power consumption. When the A/D converter function is disabled, the contents of the A/D data register pair known as SADOH and SADOL will be unchanged.
- Bit 4 **ADRF5**: A/D converter data format selection  
0: A/D converter data format → SADOH=D[11:4]; SADOL=D[3:0]  
1: A/D converter data format → SADOH=D[11:8]; SADOL=D[7:0]  
This bit controls the format of the 12-bit converted A/D value in the two A/D data registers. Details are provided in the A/D data register section.
- Bit 3~0 **SACS3~SACS0**: A/D converter external analog input channel selection  
0000: AN0  
0001: AN1  
0010: AN2  
0011: AN3  
0100: AN4  
0101: AN5  
0110: AN6  
0111~1111: Non-existed channel, the input will be floating

• SADC1 Register

Bit	7	6	5	4	3	2	1	0
Name	SAINS2	SAINS1	SAINS0	SAVRS1	SAVRS0	SACKS2	SACKS1	SACKS0
R/W	R/W	R/W	R/W	R/W	R/W	R/W	R/W	R/W
POR	0	0	0	0	0	0	0	0

- Bit 7~5 **SAINS2~SAINS0**: A/D converter input signal selection  
000: External input – External analog channel input  
001: Internal input – Internal OPA2 output voltage, 20×A2P  
010~100: Unused, connected to ground  
101~111: External input – External analog channel input  
Care must be taken if the SAINS2~SAINS0 bits are set to “001” to select the internal analog signal to be converted. When the internal analog signal is selected to be converted, the external input pin must never be selected as the A/D input signal by

properly setting the SACS3~SACS0 bits with a value from 0111 to 1111. Otherwise, the external channel input will be connected together with the internal analog signal. This will result in unpredictable situations such as an irreversible damage.

Bit 4~3 **SAVRS1~SAVRS0**: A/D converter reference voltage selection

- 00: External VREF pin
- 01: Internal A/D converter power supply,  $AV_{DD}$
- 1x: External VREF pin

These bits are used to select the A/D converter reference voltage. Care must be taken if the SAVRS1~SAVRS0 bits are set to “01” to select the internal A/D converter power supply as the reference voltage source. When the internal A/D converter power supply is selected as the reference voltage, the VREF pin cannot be configured as the reference voltage input by properly configuring the corresponding pin-shared function control bits. Otherwise, the external input voltage on the VREF pin will be connected together with the internal reference voltage. This will result in unpredictable situations.

Bit 2~0 **SACKS2~SACKS0**: A/D converter clock source selection

- 000:  $f_{SYS}$
- 001:  $f_{SYS}/2$
- 010:  $f_{SYS}/4$
- 011:  $f_{SYS}/8$
- 100:  $f_{SYS}/16$
- 101:  $f_{SYS}/32$
- 110:  $f_{SYS}/64$
- 111:  $f_{SYS}/128$

These three bits are used to select the clock source for the A/D converter.

### A/D Converter Operation

The START bit in the SADC0 register is used to start the A/D conversion. When the microcontroller sets this bit from low to high and then low again, an analog to digital conversion cycle will be initiated.

The ADBZ bit in the SADC0 register is used to indicate whether the analog to digital conversion process is in progress or not. This bit will be automatically set to 1 by the microcontroller after an A/D conversion is successfully initiated. When the A/D conversion is complete, the ADBZ will be cleared to 0. In addition, the corresponding A/D interrupt request flag will be set in the interrupt control register, and if the interrupts are enabled, an appropriate internal interrupt signal will be generated. This A/D internal interrupt signal will direct the program flow to the associated A/D internal interrupt address for processing. If the A/D internal interrupt is disabled, the microcontroller can poll the ADBZ bit in the SADC0 register to check whether it has been cleared as an alternative method of detecting the end of an A/D conversion cycle.

The clock source for the A/D converter, which originates from the system clock  $f_{SYS}$ , can be chosen to be either  $f_{SYS}$  or a subdivided version of  $f_{SYS}$ . The division ratio value is determined by the SACKS2~SACKS0 bits in the SADC1 register. Although the A/D clock source is determined by the system clock  $f_{SYS}$  and by bits SACKS2~SACKS0, there are some limitations on the maximum A/D clock source speed that can be selected. As the recommended range of permissible A/D clock period,  $t_{ADCK}$ , is from 0.5 $\mu$ s to 10 $\mu$ s, care must be taken for system clock frequencies. For example, if the system clock operates at a frequency of 8MHz, the SACKS2~SACKS0 bits should not be set to 000, 001 or 111. Doing so will give A/D clock periods that are less than the minimum A/D clock period or larger than the maximum A/D clock period which may result in inaccurate A/D conversion values. Refer to the following table for examples, where values marked with an asterisk \* show where, depending upon the device, special care must be taken, as the values may be exceeding the specified A/D Clock Period range.

f <sub>sys</sub>	A/D Clock Period (t <sub>ADCK</sub> )							
	SACKS[2:0] =000 (f <sub>sys</sub> )	SACKS[2:0] =001 (f <sub>sys</sub> /2)	SACKS[2:0] =010 (f <sub>sys</sub> /4)	SACKS[2:0] =011 (f <sub>sys</sub> /8)	SACKS[2:0] =100 (f <sub>sys</sub> /16)	SACKS[2:0] =101 (f <sub>sys</sub> /32)	SACKS[2:0] =110 (f <sub>sys</sub> /64)	SACKS[2:0] =111 (f <sub>sys</sub> /128)
1MHz	1μs	2μs	4μs	8μs	16μs *	32μs *	64μs *	128μs *
2MHz	500ns	1μs	2μs	4μs	8μs	16μs *	32μs *	64μs *
4MHz	250ns *	500ns	1μs	2μs	4μs	8μs	16μs *	32μs *
8MHz	125ns *	250ns *	500ns	1μs	2μs	4μs	8μs	16μs *

#### A/D Clock Period Examples

Controlling the power on/off function of the A/D converter circuitry is implemented using the ADCEN bit in the SADC0 register. This bit must be set high to power on the A/D converter. When the ADCEN bit is set high to power on the A/D converter internal circuitry, a certain delay, as indicated in the timing diagram, must be allowed before an A/D conversion is initiated. Even if no pins are selected for use as A/D inputs, if the ADCEN bit is high, then some power will still be consumed. In power conscious applications it is therefore recommended that the ADCEN is set low to reduce power consumption when the A/D converter function is not being used.

#### A/D Converter Reference Voltage

The reference voltage supply to the A/D converter can be supplied from the power supply, AV<sub>DD</sub>, or from an external reference source supplied on pin VREF. The desired selection is made using the SAVRS1~SAVRS0 bits. When the SAVRS bit field is set to “01”, the A/D converter reference voltage will come from the AV<sub>DD</sub>. Otherwise, if the SAVRS1~SAVRS0 bits are set to any other value except “01”, the A/D converter reference voltage will come from the VREF pin. As the VREF pin is pin-shared with other functions, when the VREF pin is selected as the reference voltage supply pin, the VREF pin-shared function control bit should be properly configured to disable other pin functions. However, if the internal A/D converter power is selected as the reference voltage, the VREF pin must not be configured as the reference voltage input function to avoid the internal connection between the VREF pin and A/D converter power.

The analog input values must not be allowed to exceed the value of the selected A/D reference voltage.

SAINS[1:0]	Reference	Description
00, 10, 11	VREF	External A/D converter reference pin VREF
01	AV <sub>DD</sub>	Internal A/D converter power supply voltage

#### A/D Converter Input Signals

All the external A/D analog channel input pins are pin-shared with the I/O pins as well as other functions. The corresponding control bits for each A/D external input pin in the PxS0 and PxS1 registers determine whether the input pins are setup as A/D converter analog inputs or whether they have other functions. If the pin is setup to be as an A/D analog channel input, the original pin functions will be disabled. In this way, pins can be changed under program control to change their function between A/D inputs and other functions. All pull-high resistors, which are setup through register programming, will be automatically disconnected if the pins are setup as A/D inputs. Note that it is not necessary to first setup the A/D pin as an input in the port control register to enable the A/D input as when the pin-shared function control bits enable an A/D input, the status of the port control register will be overridden.

If the SAINS2~SAINS0 bits are set to “000” or “101~111”, the external analog channel input is selected to be converted and the SACS3~SACS0 bits can determine which actual external channel

is selected to be converted. If the SAINS2~SAINS0 bits are set to “001”, the internal analog signal derived from 20×A2P is selected to be converted. Note that if the internal analog signal is selected, the external channel must be switched to a non-existent A/D input channel by properly setting the SACS3~SACS0 bits with a value from 0111 to 1111.

SAINS[2:0]	SACS[3:0]	Input Signals	Description
000, 101~111	0000~0110	AN0~AN6	External pin analog input
	0111~1111	—	Non-existent channel, input is floating
001	0111~1111	20×A2P	20 times OPA2 positive input voltage signal
010~100	0111~1111	—	Unused, connected to ground

**A/D Converter Input Signal Selection**

### Conversion Rate and Timing Diagram

A complete A/D conversion contains two parts, data sampling and data conversion. The data sampling which is defined as  $t_{ADS}$  takes 4 A/D clock periods and the data conversion takes 12 A/D clock periods. Therefore a total of 16 A/D clock periods for an external input A/D conversion which is defined as  $t_{ADC}$  are necessary.

$$\text{Maximum single A/D conversion rate} = 1 / (\text{A/D clock period} \times 16)$$

The accompanying diagram shows graphically the various stages involved in an analog to digital conversion process and its associated timing. After an A/D conversion process has been initiated by the application program, the microcontroller internal hardware will begin to carry out the conversion, during which time the program can continue with other functions. The time taken for the A/D conversion is  $16 t_{ADCK}$  where  $t_{ADCK}$  is equal to the A/D clock period.

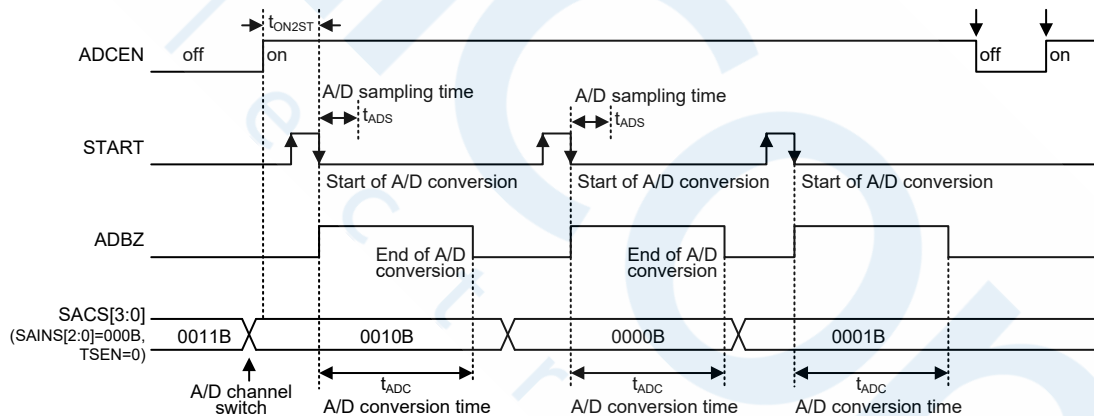

**A/D Conversion Timing – External Channel Input**

### Summary of A/D Conversion Steps

The following summarises the individual steps that should be executed in order to implement an A/D conversion process.

- Step 1  
Select the required A/D conversion clock by correctly programming bits SACKS2~SACKS0 in the SADC1 register.
- Step 2  
Enable the A/D converter by setting the ADCEN bit in the SADC0 register to 1.

- Step 3  
Select which signal is to be connected to the internal A/D converter by correctly configuring the SAINS2~SAINS0 bits.  
Select the external channel input to be converted, go to Step 4.  
Select the internal analog signal to be converted, go to Step 5.
  - Step 4  
If the A/D converter input signal comes from the external channel input selecting by configuring the SAINS2~SAINS0 bits, the corresponding pins should be configured as A/D converter input function by configuring the relevant pin-shared function control bits. The desired analog channel then should be selected by configuring the SACS3~SACS0 bits. After this step, go to Step 6.
  - Step 5  
Before the A/D converter input signal is selected to come from the internal analog signal by configuring the SAINS2~SAINS0 bits, the corresponding external input pin must be switched to a non-existent channel input by setting the SACS3~SACS0 bits with a value from 0111 to 1111. The desired internal analog signal then can be selected by configuring the SAINS2~SAINS0 bits. After this step, go to Step 6.
  - Step 6  
Select the reference voltage source by configuring the SAVRS1~SAVRS0 bits in the SADC1 register. If the A/D converter power supply voltage is selected, the external reference input pin function must be disabled by properly configuring the corresponding pin-shared control bits.
  - Step 7  
Select A/D converter output data format by setting the ADRFS bit in the SADC0 register.
  - Step 8  
If A/D conversion interrupt is used, the interrupt control registers must be correctly configured to ensure the A/D interrupt function is active. The master interrupt control bit, EMI, and the A/D conversion interrupt control bit, ADE, must both be set high in advance.
  - Step 9  
The A/D conversion procedure can now be initialized by setting the START bit from low to high and then low again.
  - Step 10  
If A/D conversion is in progress, the ADBZ flag will be set high. After the A/D conversion process is complete, the ADBZ flag will go low and then the output data can be read from SADOH and SADOL registers.
- Note: When checking for the end of the conversion process, if the method of polling the ADBZ bit in the SADC0 register is used, the interrupt enable step above can be omitted.

### **Programming Considerations**

During microcontroller operations where the A/D converter is not being used, the A/D internal circuitry can be switched off to reduce power consumption, by clearing bit ADCEN to 0 in the SADC0 register. When this happens, the internal A/D converter circuits will not consume power irrespective of what analog voltage is applied to their input lines. If the A/D converter input lines are used as normal I/O pins, then care must be taken as if the input voltage is not at a valid logic level, then this may lead to some increase in power consumption.

### A/D Conversion Function

As the device contains a 12-bit A/D converter, its full-scale converted digitised value is equal to FFFH. Since the full-scale analog input value is equal to the actual A/D converter reference voltage,  $V_{REF}$ , this gives a single bit analog input value of  $V_{REF}$  divided by 4096.

$$1 \text{ LSB} = V_{REF}/4096$$

The A/D Converter input voltage value can be calculated using the following equation:

$$\text{A/D input voltage} = \text{A/D output digital value} \times (V_{REF}/4096)$$

The diagram shows the ideal transfer function between the analog input value and the digitised output value for the A/D converter. Except for the digitised zero value, the subsequent digitised values will change at a point 0.5 LSB below where they would change without the offset, and the last full scale digitised value will change at a point 1.5 LSB below the  $V_{REF}$  level.

Note that here the  $V_{REF}$  voltage is the actual A/D converter reference voltage determined by the SAVRS1~SAVRS0 bits.

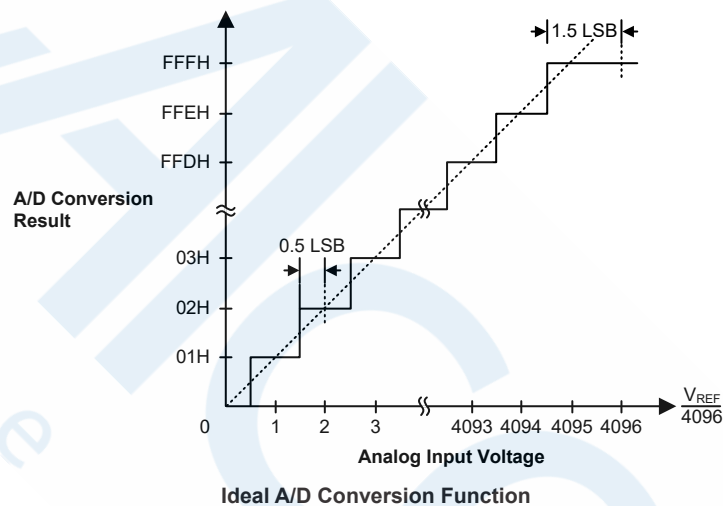

### A/D Conversion Programming Examples

The following two programming examples illustrate how to setup and implement an A/D conversion. In the first example, the method of polling the ADBZ bit in the SADC0 register is used to detect when the conversion cycle is complete, whereas in the second example, the A/D interrupt is used to determine when the conversion is complete.

#### Example: using an EOCB polling method to detect the end of conversion

```

clr ADE           ; disable A/D converter interrupt
mov a,03h
mov SADC1,a      ; select input signal from external channel input,
                 ; reference voltage form external VREF pin, fsys/8 as A/D clock

mov a,0Bh       ; setup PBS0 register to configure pin AN0
mov PBS0,a
mov a,20h
mov SADC0,a     ; enable A/D converter and connect AN0 channel to A/D converter
:
start_conversion:
clr START       ; high pulse on start bit to initiate conversion
set START      ; reset A/D
clr START      ; start A/D
    
```



```
polling_EOC:
sz ADBZ          ; poll the SADC0 register ADBZ bit to detect end of A/D conversion
jmp polling_EOC ; continue polling
mov a,SADOL      ; read low byte conversion result value
mov SADOL_buffer,a ; save result to user defined register
mov a,SAD0H      ; read high byte conversion result value
mov SAD0H_buffer,a ; save result to user defined register
:
:
jmp start_conversion ; start next A/D conversion
```

**Example: using the interrupt method to detect the end of conversion**

```
clr ADE          ; disable A/D converter interrupt
mov a,03h        ; select input signal from external channel input,
                 ; reference voltage form external VREF pin, fsys/8 as A/D clock
mov a,0Bh        ; setup PBS0 register to configure pin AN0
mov PBS0,a
mov a,20h
mov SADC0,a      ; enable A/D and connect AN0 channel to A/D converter
Start_conversion:
clr START        ; high pulse on START bit to initiate conversion
set START        ; reset A/D
clr START        ; start A/D
clr ADF          ; clear ADC interrupt request flag
set ADE          ; enable A/D converter interrupt
set EMI          ; enable global interrupt
:
:
; ADC interrupt service routine
ADC_ISR:
mov acc_stack,a ; save ACC to user defined memory
mov a,STATUS
mov status_stack,a ; save STATUS to user defined memory
:
:
mov a,SADOL      ; read low byte conversion result value
mov SADOL_buffer,a ; save result to user defined register
mov a,SAD0H      ; read high byte conversion result value
mov SAD0H_buffer,a ; save result to user defined register
:
:
EXIT_INT_ISR:
mov a,status_stack
mov STATUS,a    ; restore STATUS from user defined memory
mov a,acc_stack ; restore ACC from user defined memory
reti
```

## Battery Charge Module

The device contains a battery charge module which consists of three operational amplifiers, a 14-bit and a 12-bit D/A converters. The OPA0 together with DAC0 and OPA1 together with DAC1 are used for battery charge constant current (CC) and constant voltage (CV) control respectively. The OPA2 is used for battery charge current amplification.

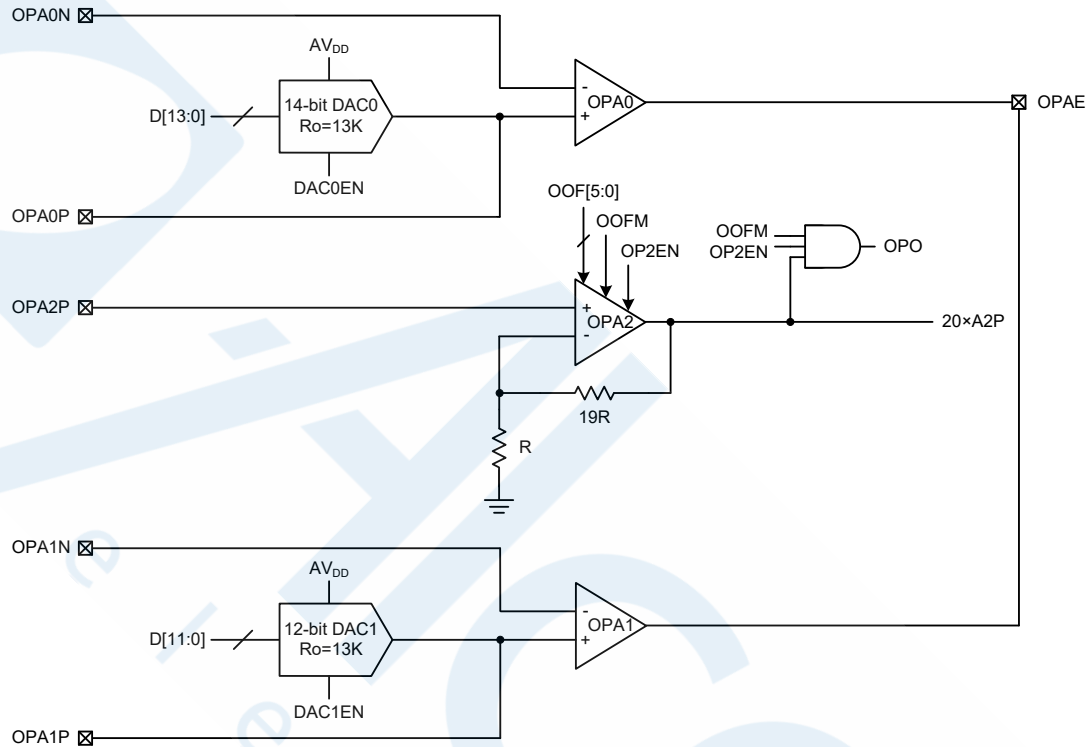

**Battery Charge Module Structure**

- Note:
1. The OPA0 and OPA1 are always enabled, while the OPA2 is controlled by the OP2EN bit in DAOPC register.
  2. The OPA0 and OPA1 are open drain outputs.
  3. The OPA0 and OPA1 do not need to calibrate the input offset.
  4. The OPA2 needs to calibrate the input offset.
  5. When the DAC0 or DAC1 is disabled, the output will be in a floating state.

### Battery Charge Module Registers

Overall operation of the battery charge module is controlled using a series of registers and the corresponding register definitions are described in the accompanying sections.

Register Name	Bit							
	7	6	5	4	3	2	1	0
DA0L	D7	D6	D5	D4	D3	D2	D1	D0
DA0H	—	—	D13	D12	D11	D10	D9	D8
DA1L	D7	D6	D5	D4	D3	D2	D1	D0
DA1H	—	—	—	—	D11	D10	D9	D8
DAOPC	DAC1EN	DAC0EN	OP2EN	—	—	—	—	OPO
OPVOS	OOFM	—	OOF5	OOF4	OOF3	OOF2	OOF1	OOF0

**Battery Charge Module Register List**



## Digital to Analog Converter

The battery charge module contains a 14-bit and 12-bit R2R D/A converters, namely DAC0 and DAC1. Their reference input voltage comes from  $AV_{DD}$ , and can be power down to save power.

The DAC0 and DAC1 are enabled or disabled by the DAOPC register. They are used to set a reference charging current and voltage using the DA0H/DA0L and DA1H/DA1L registers respectively.

### • DA0L Register

Bit	7	6	5	4	3	2	1	0
Name	D7	D6	D5	D4	D3	D2	D1	D0
R/W	R/W	R/W	R/W	R/W	R/W	R/W	R/W	R/W
POR	1	0	0	0	0	0	1	0

Bit 7~0 **D7~D0**: D/A converter 0 output control code low byte

Writing this register will only write the data to a shadow buffer and writing the DA0H register will simultaneously copy the shadow buffer data to the DA0L register.

### • DA0H Register

Bit	7	6	5	4	3	2	1	0
Name	—	—	D13	D12	D11	D10	D9	D8
R/W	—	—	R/W	R/W	R/W	R/W	R/W	R/W
POR	—	—	0	0	0	0	0	0

Bit 7~6 Unimplemented, read as “0”

Bit 5~0 **D13~D8**: D/A converter 0 output control code high byte

The D/A converter 0 output voltage is calculated using the following equation:

$DAC0OUT = (AV_{DD}/2^{14}) \times D[13:0]$ , where  $AV_{DD}$  is D/A converter 0 reference input voltage.

### • DA1L Register

Bit	7	6	5	4	3	2	1	0
Name	D7	D6	D5	D4	D3	D2	D1	D0
R/W	R/W	R/W	R/W	R/W	R/W	R/W	R/W	R/W
POR	0	0	0	0	0	0	0	0

Bit 7~0 **D7~D0**: D/A converter 1 output control code low byte

Writing this register will only write the data to a shadow buffer and writing the DA1H register will simultaneously copy the shadow buffer data to the DA1L register.

### • DA1H Register

Bit	7	6	5	4	3	2	1	0
Name	—	—	—	—	D11	D10	D9	D8
R/W	—	—	—	—	R/W	R/W	R/W	R/W
POR	—	—	—	—	1	0	0	0

Bit 7~4 Unimplemented, read as “0”

Bit 3~0 **D11~D8**: D/A converter 1 output control code high byte

The D/A converter 1 output voltage is calculated using the following equation:

$DAC1OUT = (AV_{DD}/2^{12}) \times D[11:0]$ , where  $AV_{DD}$  is D/A converter 1 reference input voltage.

**• DAOPC Register**

Bit	7	6	5	4	3	2	1	0
Name	DAC1EN	DAC0EN	OP2EN	—	—	—	—	OPO
R/W	R/W	R/W	R/W	—	—	—	—	R
POR	1	1	0	—	—	—	—	0

- Bit 7     **DAC1EN**: D/A converter 1 enable control  
0: Disable, D/A converter 1 output floating  
1: Enable
- Bit 6     **DAC0EN**: D/A converter 0 enable control  
0: Disable, D/A converter 0 output floating  
1: Enable
- Bit 5     **OP2EN**: OPA2 enable control  
0: Disable  
1: Enable
- Bit 4~1   Unimplemented, read as “0”
- Bit 0     **OPO**: OPA2 digital logic output  
The OPO is cleared to 0 when the OPA2 is disabled.

**Operational Amplifiers**

The battery charge module contains three operational amplifiers, namely OPA0, OPA1 and OPA2. The OPA0 and OPA1 are always enabled and do not need to calibrate the input offset. The OPA2 related functions are controlled using the DAOPC and OPVOS registers.

The DAOPC register is used for control OPA2 enable/disable and output status monitoring. The OPVOS register is used for OPA2 input offset calibration voltage selection and control.

**• OPVOS Register**

Bit	7	6	5	4	3	2	1	0
Name	OOFM	—	OOF5	OOF4	OOF3	OOF2	OOF1	OOF0
R/W	R/W	—	R/W	R/W	R/W	R/W	R/W	R/W
POR	0	—	1	0	0	0	0	0

- Bit 7     **OOFM**: OPA2 normal operation or input offset voltage cancellation mode selection bit  
0: Normal operation  
1: Offset calibration mode  
The input reference voltage comes from OPA2 positive input pin at offset voltage cancellation mode.
- Bit 6     Unimplemented, read as “0”
- Bit 5~0   **OOF5~OOF0**: OPA2 input offset voltage calibration control bits

**Operational Amplifier 2 Operation**

The OPA2 provides input offset calibration function. The calibrated data is stored in the OOF5~OOF0 bits. The OOFM bit is used to control cancellation mode selection. The input reference voltage comes from the OPA2P pin in calibration mode. The OPA2P pin is the OPA2 positive input and the 20×A2P signal is the OPA2 analog output voltage. The OPA2 digital output flag is OPO, which is used for OPA2 calibration mode. Finally, the OP2EN bit is used to enable or disable the OPA2 function.

### Offset Calibration Procedure

As the OPA2 input pin is pin-shared with other functions, it should be configured as the operational amplifier input first by the corresponding pin-shared function selection register.

- Step1: Set OOFM=1, the OPA2 is now under offset calibration mode. To make sure the input offset voltage  $V_{OS}$  as minimise as possible after calibration, the input reference voltage in calibration mode should be the same as input DC operating voltage in normal mode operation.
- Step2: Set OOF[5:0]=000000 then read OPO flag.
- Step3: Let OOF[5:0]=OOF[5:0]+1 then read OPO flag, if the OPO flag state is changed, record the data as  $V_{OS1}$ .
- Step4: Set OOF[5:0]=111111 then read OPO flag.
- Step5: Let OOF[5:0]=OOF[5:0]-1 then read OPO flag, if the OPO flag state is changed; record the data as  $V_{OS2}$ .
- Step6: restore  $V_{OS}=(V_{OS1}+V_{OS2})/2$  to OOF[5:0] bits, the calibration is finished.  
If  $(V_{OS1}+V_{OS2})/2$  is not integral, discard the decimal.  
Residue  $V_{OS}=V_{OUT}-V_{IN}$ .

### UART Interface

The device contains an integrated full-duplex or half-duplex asynchronous serial communications UART interface that enables communication with external devices that contain a serial interface. The UART function has many features and can transmit and receive data serially by transferring a frame of data with eight or nine data bits per transmission as well as being able to detect errors when the data is overwritten or incorrectly framed. The UART function possesses its own internal interrupt which can be used to indicate when a reception occurs or when a transmission terminates.

The integrated UART function contains the following features:

- Full-duplex or half-duplex (single wire mode) asynchronous communication
- 8 or 9 bits character length
- Even, odd or no parity options
- One or two stop bits
- Baud rate generator with 8-bit prescaler
- Parity, framing, noise and overrun error detection
- Support for interrupt on address detect (last character bit=1)
- Separately enabled transmitter and receiver
- 2-byte Deep FIFO Receive Data Buffer
- RX/TX pin wake-up function
- Transmit and receive interrupts
- Interrupts can be triggered by the following conditions:
  - ♦ Transmitter Empty
  - ♦ Transmitter Idle
  - ♦ Receiver Full
  - ♦ Receiver Overrun
  - ♦ Address Mode Detect

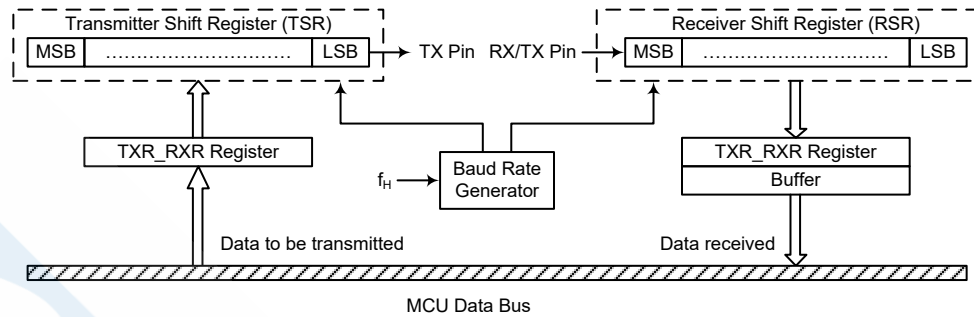

UART Data Transfer Block Diagram – SWM=0

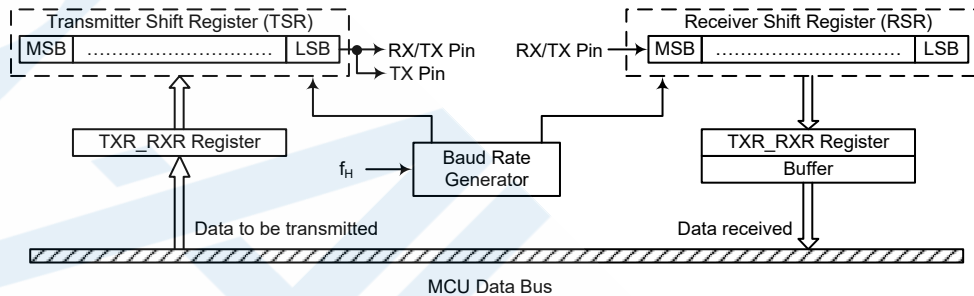

UART Data Transfer Block Diagram – SWM=1

### UART External Pins

To communicate with an external serial interface, the internal UART has two external pins known as TX and RX/TX, which are pin-shared with I/O or other pin functions. The TX and RX/TX pin function should first be selected by the corresponding pin-shared function selection register before the UART function is used. Along with the UARTEN bit, the TXEN and RXEN bits, if set, will configure these pins to transmitter output and receiver input conditions. At this time the internal pull-high resistor related to the transmitter output pin will be disabled, while the internal pull-high resistor related to the receiver input pin is controlled by the corresponding I/O pull-high function control bit. When the TX or RX/TX pin function is disabled by clearing the UARTEN, TXEN or RXEN bit, the TX or RX/TX pin will be placed to a floating state. At this time whether the internal pull-high resistor is connected to the TX or RX/TX pin or not is determined by the corresponding I/O pull-high function control bit.

### UART Single Wire Mode

The UART function also supports the Single Wire Mode communication which is selected using the SWM bit in the UCR3 register. When the SWM bit is set high, the UART function will be in the single wire mode. In the single wire mode, a single RX/TX pin can be used to transmit and receive data depending upon the corresponding control bits. When the RXEN bit is set high, the RX/TX pin is used as a receiver pin. When the RXEN bit is cleared to zero and the TXEN bit is set high, the RX/TX pin will act as a transmitter pin.

It is recommended not to set both the RXEN and TXEN bits high in the single wire mode. If both the RXEN and TXEN bits are set high, the RXEN bit will have the priority and the UART will act as a receiver.

It is important to note that the functional description in this UART Interface chapter, which is described from the full-duplex communication standpoint, also applies to the half-duplex (single wire mode)

communication except the pin usage. In the single wire mode, the TX pin mentioned in this chapter should be replaced by the RX/TX pin to understand the whole UART single wire mode function.

In the single wire mode, the data can also be transmitted on the TX pin in a transmission operation with proper software configurations. Therefore, the data will be output on the RX/TX and TX pins.

### UART Data Transfer Scheme

The UART Data Transfer Block Diagram shows the overall data transfer structure arrangement for the UART. The actual data to be transmitted from the MCU is first transferred to the TXR\_RXR register by the application program. The data will then be transferred to the Transmit Shift Register from where it will be shifted out, LSB first, onto the TX pin at a rate controlled by the Baud Rate Generator. Only the TXR\_RXR register is mapped onto the MCU Data Memory, the Transmit Shift Register is not mapped and is therefore inaccessible to the application program.

Data to be received by the UART is accepted on the external RX/TX pin, from where it is shifted in, LSB first, to the Receiver Shift Register at a rate controlled by the Baud Rate Generator. When the shift register is full, the data will then be transferred from the shift register to the internal TXR\_RXR register, where it is buffered and can be manipulated by the application program. Only the TXR\_RXR register is mapped onto the MCU Data Memory, the Receiver Shift Register is not mapped and is therefore inaccessible to the application program.

It should be noted that the actual register for data transmission and reception only exists as a single shared register in the Data Memory. This shared register known as the TXR\_RXR register is used for both data transmission and data reception.

### UART Status and Control Registers

There are six control registers associated with the UART function. The USR, UCR1, UCR2 and UCR3 registers control the overall function of the UART, while the BRG register controls the Baud rate. The actual data to be transmitted and received on the serial interface is managed through the TXR\_RXR data register.

Register Name	Bit							
	7	6	5	4	3	2	1	0
USR	PERR	NF	FERR	OERR	RIDLE	RXIF	TIDLE	TXIF
UCR1	UARTEN	BNO	PREN	PRT	STOPS	TXBRK	RX8	TX8
UCR2	TXEN	RXEN	BRGH	ADDEN	WAKE	RIE	TIIE	TEIE
UCR3	—	—	—	—	—	—	—	SWM
TXR_RXR	TXRX7	TXRX6	TXRX5	TXRX4	TXRX3	TXRX2	TXRX1	TXRX0
BRG	D7	D6	D5	D4	D3	D2	D1	D0

UART Register List

#### • USR Register

The USR register is the status register for the UART, which can be read by the program to determine the present status of the UART. All flags within the USR register are read only. Further explanation on each of the flags is given below:

Bit	7	6	5	4	3	2	1	0
Name	PERR	NF	FERR	OERR	RIDLE	RXIF	TIDLE	TXIF
R/W	R	R	R	R	R	R	R	R
POR	0	0	0	0	1	0	1	1

Bit 7 **PERR**: Parity error flag  
 0: No parity error is detected  
 1: Parity error is detected

The PERR flag is the parity error flag. When this read only flag is “0”, it indicates a parity error has not been detected. When the flag is “1”, it indicates that the parity of the received word is incorrect. This error flag is applicable only if Parity mode (odd or even) is selected. The flag can also be cleared by a software sequence which involves a read to the status register USR followed by an access to the TXR\_RXR data register.

Bit 6

**NF:** Noise flag  
0: No noise is detected  
1: Noise is detected

The NF flag is the noise flag. When this read only flag is “0”, it indicates no noise condition. When the flag is “1”, it indicates that the UART has detected noise on the receiver input. The NF flag is set during the same cycle as the RXIF flag but will not be set in the case of an overrun. The NF flag can be cleared by a software sequence which will involve a read to the status register USR followed by an access to the TXR\_RXR data register.

Bit 5

**FERR:** Framing error flag  
0: No framing error is detected  
1: Framing error is detected

The FERR flag is the framing error flag. When this read only flag is “0”, it indicates that there is no framing error. When the flag is “1”, it indicates that a framing error has been detected for the current character. The flag can also be cleared by a software sequence which will involve a read to the status register USR followed by an access to the TXR\_RXR data register.

Bit 4

**OERR:** Overrun error flag  
0: No overrun error is detected  
1: Overrun error is detected

The OERR flag is the overrun error flag which indicates when the receiver buffer has overflowed. When this read only flag is “0”, it indicates that there is no overrun error. When the flag is “1”, it indicates that an overrun error occurs which will inhibit further transfers to the TXR\_RXR receive data register. The flag is cleared by a software sequence, which is a read to the status register USR followed by an access to the TXR\_RXR data register.

Bit 3

**RIDLE:** Receiver status  
0: Data reception is in progress (Data being received)  
1: No data reception is in progress (Receiver is idle)

The RIDLE flag is the receiver status flag. When this read only flag is “0”, it indicates that the receiver is between the initial detection of the start bit and the completion of the stop bit. When the flag is “1”, it indicates that the receiver is idle. Between the completion of the stop bit and the detection of the next start bit, the RIDLE bit is “1” indicating that the UART receiver is idle and the RX/TX pin stays in logic high condition.

Bit 2

**RXIF:** Receive TXR\_RXR data register status  
0: TXR\_RXR data register is empty  
1: TXR\_RXR data register has available data

The RXIF flag is the receive data register status flag. When this read only flag is “0”, it indicates that the TXR\_RXR read data register is empty. When the flag is “1”, it indicates that the TXR\_RXR read data register contains new data. When the contents of the shift register are transferred to the TXR\_RXR register, an interrupt is generated if RIE=1 in the UCR2 register. If one or more errors are detected in the received word, the appropriate receive-related flags NF, FERR, and/or PERR are set within the same clock cycle. The RXIF flag will eventually be cleared when the USR register is read with RXIF set, followed by a read from the TXR\_RXR register, and if the TXR\_RXR register has no more new data available.

Bit 1

**TIDLE:** Transmission idle  
0: Data transmission is in progress (Data being transmitted)  
1: No data transmission is in progress (Transmitter is idle)



The TIDLE flag is known as the transmission complete flag. When this read only flag is “0”, it indicates that a transmission is in progress. This flag will be set high when the TXIF flag is “1” and when there is no transmit data or break character being transmitted. When TIDLE is equal to “1”, the TX pin becomes idle with the pin state in logic high condition. The TIDLE flag is cleared by reading the USR register with TIDLE set and then writing to the TXR\_RXR register. The flag is not generated when a data character or a break is queued and ready to be sent.

Bit 0

**TXIF:** Transmit TXR\_RXR data register status

0: Character is not transferred to the transmit shift register

1: Character has transferred to the transmit shift register (TXR\_RXR data register is empty)

The TXIF flag is the transmit data register empty flag. When this read only flag is “0”, it indicates that the character is not transferred to the transmitter shift register. When the flag is “1”, it indicates that the transmitter shift register has received a character from the TXR\_RXR data register. The TXIF flag is cleared by reading the UART status register (USR) with TXIF set and then writing to the TXR\_RXR data register. Note that when the TXEN bit is set, the TXIF flag bit will also be set since the transmit data register is not yet full.

#### • UCR1 Register

The UCR1 register together with the UCR2 and UCR3 registers are the three UART control registers that are used to set the various options for the UART function, such as overall on/off control, parity control, data transfer bit length, single wire mode communication etc. Further explanation on each of the bits is given below:

Bit	7	6	5	4	3	2	1	0
Name	UARTEN	BNO	PREN	PRT	STOPS	TXBRK	RX8	TX8
R/W	R/W	R/W	R/W	R/W	R/W	R/W	R	W
POR	0	0	0	0	0	0	x	0

“x”: unknown

Bit 7

**UARTEN:** UART function enable control

0: Disable UART. TX and RX/TX pins are in a floating state

1: Enable UART. TX and RX/TX pins function as UART pins

The UARTEN bit is the UART enable bit. When this bit is equal to “0”, the UART will be disabled and the RX/TX pin as well as the TX pin will be in the floating state. When the bit is equal to “1” the UART will be enabled and the TX and RX/TX pins will function as defined by SWM mode selection bit together with the TXEN and RXEN enable control bits.

When the UART is disabled, it will empty the buffer so any character remaining in the buffer will be discarded. In addition, the value of the baud rate counter will be reset. If the UART is disabled, all error and status flags will be reset. Also the TXEN, RXEN, TXBRK, RXIF, OERR, FERR, PERR and NF bits will be cleared, while the TIDLE, TXIF and RIDLE bits will be set. Other control bits in UCR1, UCR2, UCR3 and BRG registers will remain unaffected. If the UART is active and the UARTEN bit is cleared, all pending transmissions and receptions will be terminated and the module will be reset as defined above. When the UART is re-enabled, it will restart in the same configuration.

Bit 6

**BNO:** Number of data transfer bits selection

0: 8-bit data transfer

1: 9-bit data transfer

This bit is used to select the data length format, which can have a choice of either 8-bit or 9-bit format. When this bit is equal to “1”, a 9-bit data length format will be selected. If the bit is equal to “0”, then an 8-bit data length format will be selected. If 9-bit data length format is selected, then bits RX8 and TX8 will be used to store the 9th bit of the received and transmitted data respectively.

- Bit 5     **PREN**: Parity function enable control  
           0: Parity function is disabled  
           1: Parity function is enabled  
 This is the parity enable bit. When this bit is equal to “1”, the parity function will be enabled. If the bit is equal to “0”, then the parity function will be disabled.
- Bit 4     **PRT**: Parity type selection bit  
           0: Even parity for parity generator  
           1: Odd parity for parity generator  
 This bit is the parity type selection bit. When this bit is equal to “1”, odd parity type will be selected. If the bit is equal to “0”, then even parity type will be selected.
- Bit 3     **STOPS**: Number of Stop bits selection for transmitter  
           0: One stop bit format is used  
           1: Two stop bits format is used  
 This bit determines if one or two stop bits are to be used for transmitter. When this bit is equal to “1”, two stop bits are used. If this bit is equal to “0”, then only one stop bit is used.
- Bit 2     **TXBRK**: Transmit break character  
           0: No break character is transmitted  
           1: Break characters transmit  
 The TXBRK bit is the Transmit Break Character bit. When this bit is “0”, there are no break characters and the TX pin operates normally. When the bit is “1”, there are transmit break characters and the transmitter will send logic zeros. When this bit is equal to “1”, after the buffered data has been transmitted, the transmitter output is held low for a minimum of a 13-bit length and until the TXBRK bit is reset.
- Bit 1     **RX8**: Receive data bit 8 for 9-bit data transfer format (read only)  
 This bit is only used if 9-bit data transfers are used, in which case this bit location will store the 9th bit of the received data known as RX8. The BNO bit is used to determine whether data transfers are in 8-bit or 9-bit format.
- Bit 0     **TX8**: Transmit data bit 8 for 9-bit data transfer format (write only)  
 This bit is only used if 9-bit data transfers are used, in which case this bit location will store the 9th bit of the transmitted data known as TX8. The BNO bit is used to determine whether data transfers are in 8-bit or 9-bit format.

• **UCR2 Register**

The UCR2 register is the second of the three UART control registers and serves several purposes. One of its main functions is to control the basic enable/disable operation of the UART Transmitter and Receiver as well as enabling the various UART interrupt sources. The register also serves to control the baud rate speed, receiver wake-up enable and the address detect enable. Further explanation on each of the bits is given below:

Bit	7	6	5	4	3	2	1	0
Name	TXEN	RXEN	BRGH	ADDEN	WAKE	RIE	TIIE	TEIE
R/W	R/W	R/W	R/W	R/W	R/W	R/W	R/W	R/W
POR	0	0	0	0	0	0	0	0

- Bit 7     **TXEN**: UART Transmitter enabled control  
           0: UART transmitter is disabled  
           1: UART transmitter is enabled  
 The bit named TXEN is the Transmitter Enable Bit. When this bit is equal to “0”, the transmitter will be disabled with any pending data transmissions being aborted. In addition the buffers will be reset. In this situation the TX pin will be in a floating state. If the TXEN bit is equal to “1” and the UARTEEN bit is also equal to “1”, the transmitter will be enabled and the TX pin will be controlled by the UART. Clearing the TXEN bit during a transmission will cause the data transmission to be aborted and will reset the transmitter. If this situation occurs, the TX pin will be in a floating state.



- Bit 6     **RXEN:** UART Receiver enabled control  
           0: UART receiver is disabled  
           1: UART receiver is enabled
- The bit named RXEN is the Receiver Enable Bit. When this bit is equal to “0”, the receiver will be disabled with any pending data receptions being aborted. In addition the receive buffers will be reset. In this situation the RX/TX pin will be in a floating state. If the RXEN bit is equal to “1” and the UARTEN bit is also equal to “1”, the receiver will be enabled and the RX/TX pin will be controlled by the UART. Clearing the RXEN bit during a reception will cause the data reception to be aborted and will reset the receiver. If this situation occurs, the RX/TX pin will be in a floating state.
- Bit 5     **BRGH:** Baud Rate speed selection  
           0: Low speed baud rate  
           1: High speed baud rate
- The bit named BRGH selects the high or low speed mode of the Baud Rate Generator. This bit, together with the value placed in the baud rate register BRG, controls the Baud Rate of the UART. If this bit is equal to “1”, the high speed mode is selected. If the bit is equal to “0”, the low speed mode is selected.
- Bit 4     **ADDEN:** Address detect function enable control  
           0: Address detect function is disabled  
           1: Address detect function is enabled
- The bit named ADDEN is the address detect function enable control bit. When this bit is equal to “1”, the address detect function is enabled. When it occurs, if the 8th bit, which corresponds to TXRX7 if BNO=0 or the 9th bit, which corresponds to RX8 if BNO=1, has a value of “1”, then the received word will be identified as an address, rather than data. If the corresponding interrupt is enabled, an interrupt request will be generated each time the received word has the address bit set, which is the 8th or 9th bit depending on the value of BNO. If the address bit known as the 8th or 9th bit of the received word is “0” with the address detect function being enabled, an interrupt will not be generated and the received data will be discarded.
- Bit 3     **WAKE:** RX/TX pin wake-up UART function enable control  
           0: RX/TX pin wake-up UART function is disabled  
           1: RX/TX pin wake-up UART function is enabled
- This bit is used to control the wake-up UART function when a falling edge on the RX/TX pin occurs. Note that this bit is only available when the UART clock ( $f_{H}$ ) is switched off. There will be no RX/TX pin wake-up UART function if the UART clock ( $f_{H}$ ) exists. If the WAKE bit is set to 1 as the UART clock ( $f_{H}$ ) is switched off, a UART wake-up request will be initiated when a falling edge on the RX/TX pin occurs. When this request happens and the corresponding interrupt is enabled, an RX/TX pin wake-up UART interrupt will be generated to inform the MCU to wake up the UART function by switching on the UART clock ( $f_{H}$ ) via the application program. Otherwise, the UART function cannot resume even if there is a falling edge on the RX/TX pin when the WAKE bit is cleared to 0.
- Bit 2     **RIE:** Receiver interrupt enable control  
           0: Receiver related interrupt is disabled  
           1: Receiver related interrupt is enabled
- This bit enables or disables the receiver interrupt. If this bit is equal to “1” and when the receiver overrun flag OERR or receive data available flag RXIF is set, the UART interrupt request flag will be set. If this bit is equal to “0”, the UART interrupt request flag will not be influenced by the condition of the OERR or RXIF flags.
- Bit 1     **TIE:** Transmitter Idle interrupt enable control  
           0: Transmitter idle interrupt is disabled  
           1: Transmitter idle interrupt is enabled
- This bit enables or disables the transmitter idle interrupt. If this bit is equal to “1” and when the transmitter idle flag TIDLE is set, due to a transmitter idle condition, the UART interrupt request flag will be set. If this bit is equal to “0”, the UART interrupt request flag will not be influenced by the condition of the TIDLE flag.

Bit 0 **TEIE**: Transmitter Empty interrupt enable control  
 0: Transmitter empty interrupt is disabled  
 1: Transmitter empty interrupt is enabled  
 This bit enables or disables the transmitter empty interrupt. If this bit is equal to “1” and when the transmitter empty flag TXIF is set, due to a transmitter empty condition, the UART interrupt request flag will be set. If this bit is equal to “0”, the UART interrupt request flag will not be influenced by the condition of the TXIF flag.

• **UCR3 Register**

The UCR3 register is used to enable the UART Single Wire Mode communication. As the name suggests in the single wire mode the UART communication can be implemented in one single line, RX/TX, together with the control of the RXEN and TXEN bits in the UCR2 register.

Bit	7	6	5	4	3	2	1	0
Name	—	—	—	—	—	—	—	SWM
R/W	—	—	—	—	—	—	—	R/W
POR	—	—	—	—	—	—	—	0

Bit 7~1 Unimplemented, read as “0”

Bit 0 **SWM**: Single Wire Mode enable control  
 0: Disable, the RX/TX pin is used as UART receiver function only  
 1: Enable, the RX/TX pin can be used as UART receiver or transmitter function controlled by the RXEN and TXEN bits

Note that when the Single Wire Mode is enabled, if both the RXEN and TXEN bits are high, the RX/TX pin will only be used as UART receiver input.

• **TXR\_RXR Register**

The TXR\_RXR register is the data register which is used to store the data to be transmitted on the TX pin or being received from the RX/TX pin.

Bit	7	6	5	4	3	2	1	0
Name	TXRX7	TXRX6	TXRX5	TXRX4	TXRX3	TXRX2	TXRX1	TXRX0
R/W	R/W	R/W	R/W	R/W	R/W	R/W	R/W	R/W
POR	x	x	x	x	x	x	x	x

“x”: unknown

Bit 7~0 **TXRX7~TXRX0**: UART Transmit/Receive Data bit 7 ~ bit 0

• **BRG Register**

Bit	7	6	5	4	3	2	1	0
Name	D7	D6	D5	D4	D3	D2	D1	D0
R/W	R/W	R/W	R/W	R/W	R/W	R/W	R/W	R/W
POR	x	x	x	x	x	x	x	x

“x”: unknown

Bit 7~0 **D7~D0**: Baud Rate values

By programming the BRGH bit in UCR2 Register which allows selection of the related formula described above and programming the required value in the BRG register, the required baud rate can be set.

Note: Baud rate= $f_H/[64 \times (N+1)]$  if BRGH=0.

Baud rate= $f_H/[16 \times (N+1)]$  if BRGH=1.

## Baud Rate Generator

To set the speed of the serial data communication, the UART function contains its own dedicated baud rate generator. The baud rate is controlled by its own internal free running 8-bit timer, the period of which is determined by two factors. The first of these is the value placed in the baud rate register BRG and the second is the value of the BRGH bit with the control register UCR2. The BRGH bit decides if the baud rate generator is to be used in a high speed mode or low speed mode, which in turn determines the formula that is used to calculate the baud rate. The value N in the BRG register which is used in the following baud rate calculation formula determines the division factor. Note that N is the decimal value placed in the BRG register and has a range of between 0 and 255.

UCR2 BRGH Bit	0	1
Baud Rate (BR)	$f_H/[64 (N+1)]$	$f_H/[16 (N+1)]$

By programming the BRGH bit which allows selection of the related formula and programming the required value in the BRG register, the required baud rate can be set. Note that because the actual baud rate is determined using a discrete value, N, placed in the BRG register, there will be an error associated between the actual and requested value. The following example shows how the BRG register value N and the error value can be calculated.

### Calculating the Baud Rate and Error Values

For a clock frequency of 4MHz, and with BRGH cleared to zero determine the BRG register value N, the actual baud rate and the error value for a desired baud rate of 4800.

From the above table the desired baud rate  $BR=f_H/[64 (N+1)]$

Re-arranging this equation gives  $N=[f_H/(BR \times 64)] - 1$

Giving a value for  $N=[4000000/(4800 \times 64)] - 1=12.0208$

To obtain the closest value, a decimal value of 12 should be placed into the BRG register. This gives an actual or calculated baud rate value of  $BR=4000000/[64 \times (12+1)]=4808$

Therefore the error is equal to  $(4808 - 4800)/4800=0.16\%$

## UART Setup and Control

For data transfer, the UART function utilizes a non-return-to-zero, more commonly known as NRZ, format. This is composed of one start bit, eight or nine data bits, and one or two stop bits. Parity is supported by the UART hardware, and can be setup to be even, odd or no parity. For the most common data format, 8 data bits along with no parity and one stop bit, denoted as 8, N, 1, is used as the default setting, which is the setting at power-on. The number of data bits and stop bits, along with the parity, are set by programming the corresponding BNO, PRT, PREN, and STOPS bits in the UCR1 register. The baud rate used to transmit and receive data is set using the internal 8-bit baud rate generator, while the data is transmitted and received LSB first. Although the UART transmitter and receiver are functionally independent, they both use the same data format and baud rate. In all cases stop bits will be used for data transmission.

### Enabling/Disabling the UART Interface

The basic on/off function of the internal UART function is controlled using the UARTEN bit in the UCR1 register. If the UARTEN, TXEN and RXEN bits are set, then these two UART pins will act as normal TX output pin and RX/TX input pin respectively. If no data is being transmitted on the TX pin, then it will default to a logic high value.

Clearing the UARTEN bit will disable the TX and RX/TX pins and allow these two pins to be in a floating state. When the UART function is disabled the buffer will be reset to an empty condition, at the same time discarding any remaining residual data. Disabling the UART will also reset the

error and status flags with bits TXEN, RXEN, TXBRK, RXIF, OERR, FERR, PERR and NF being cleared while bits TIDLE, TXIF and RIDLE will be set. The remaining control bits in the UCR1, UCR2, UCR3 and BRG registers will remain unaffected. If the UARTEN bit in the UCR1 register is cleared while the UART is active, then all pending transmissions and receptions will be immediately suspended and the UART will be reset to a condition as defined above. If the UART is then subsequently re-enabled, it will restart again in the same configuration.

### Data, Parity and Stop Bit Selection

The format of the data to be transferred is composed of various factors such as data bit length, parity on/off, parity type, address bits and the number of stop bits. These factors are determined by the setup of various bits within the UCR1 register. The BNO bit controls the number of data bits which can be set to either 8 or 9, the PRT bit controls the choice of odd or even parity, the PREN bit controls the parity on/off function and the STOPS bit decides whether one or two stop bits are to be used. The following table shows various formats for data transmission. The address bit, which is the MSB of the data byte, identifies the frame as an address character or data if the address detect function is enabled. The number of stop bits, which can be either one or two, is independent of the data length and is only used for the transmitter. There is only one stop bit for the receiver.

Start Bit	Data Bits	Address Bit	Parity Bit	Stop Bit
<b>Example of 8-bit Data Formats</b>				
1	8	0	0	1
1	7	0	1	1
1	7	1	0	1
<b>Example of 9-bit Data Formats</b>				
1	9	0	0	1
1	8	0	1	1
1	8	1	0	1

**Transmitter Receiver Data Format**

The following diagram shows the transmit and receive waveforms for both 8-bit and 9-bit data formats.

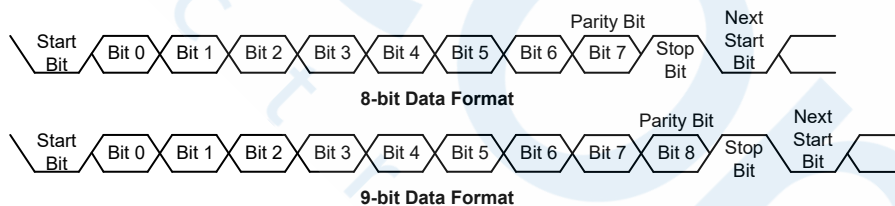

### UART Transmitter

Data word lengths of either 8 or 9 bits can be selected by programming the BNO bit in the UCR1 register. When the BNO bit is set, the word length will be set to 9 bits. In this case the 9th bit, which is the MSB, needs to be stored in the TX8 bit in the UCR1 register. At the transmitter core lies the Transmitter Shift Register, more commonly known as the TSR, whose data is obtained from the transmit data register, which is known as the TXR\_RXR register. The data to be transmitted is loaded into this TXR\_RXR register by the application program. The TSR register is not written to with new data until the stop bit from the previous transmission has been sent out. As soon as this stop bit has been transmitted, the TSR can then be loaded with new data from the TXR\_RXR register, if it is available. It should be noted that the TSR register, unlike many other registers, is not directly mapped into the Data Memory area and as such is not available to the application program

for direct read/write operations. An actual transmission of data will normally be enabled when the TXEN bit is set, but the data will not be transmitted until the TXR\_RXR register has been loaded with data and the baud rate generator has defined a shift clock source. However, the transmission can also be initiated by first loading data into the TXR\_RXR register, after which the TXEN bit can be set. When a transmission of data begins, the TSR is normally empty, in which case a transfer to the TXR\_RXR register will result in an immediate transfer to the TSR. If during a transmission the TXEN bit is cleared, the transmission will immediately cease and the transmitter will be reset. The TX output pin can then be configured as the I/O or other pin-shared function by configuring the corresponding pin-shared control bits.

### **Transmitting Data**

When the UART is transmitting data, the data is shifted on the TX pin from the shift register, with the least significant bit first. In the transmit mode, the TXR\_RXR register forms a buffer between the internal bus and the transmitter shift register. It should be noted that if 9-bit data format has been selected, then the MSB will be taken from the TX8 bit in the UCR1 register. The steps to initiate a data transfer can be summarized as follows:

- Make the correct selection of the BNO, PRT, PREN and STOPS bits to define the required word length, parity type and number of stop bits.
- Setup the BRG register to select the desired baud rate.
- Set the TXEN bit to ensure that the TX pin is used as a UART transmitter pin.
- Access the USR register and write the data that is to be transmitted into the TXR\_RXR register.

Note that this step will clear the TXIF bit.

This sequence of events can now be repeated to send additional data.

It should be noted that when TXIF=0, data will be inhibited from being written to the TXR\_RXR register. Clearing the TXIF flag is always achieved using the following software sequence:

1. A USR register access
2. A TXR\_RXR register write execution

The read-only TXIF flag is set by the UART hardware and if set indicates that the TXR\_RXR register is empty and that other data can now be written into the TXR\_RXR register without overwriting the previous data. If the TEIE bit is set then the TXIF flag will generate an interrupt.

During a data transmission, a write instruction to the TXR\_RXR register will place the data into the TXR\_RXR register, which will be copied to the shift register at the end of the present transmission. When there is no data transmission in progress, a write instruction to the TXR\_RXR register will place the data directly into the shift register, resulting in the commencement of data transmission, and the TXIF bit being immediately set. When a frame transmission is complete, which happens after stop bits are sent or after the break frame, the TIDLE bit will be set. To clear the TIDLE bit the following software sequence is used:

1. A USR register access
2. A TXR\_RXR register write execution

Note that both the TXIF and TIDLE bits are cleared by the same software sequence.

### **Transmit Break**

If the TXBRK bit is set high and the state keeps for a time of greater than  $[(BRG+1) \times t_H]$  while TIDLE=1, then break characters will be sent on the next transmission. Break character transmission consists of a start bit, followed by  $13 \times N$  '0' bits and stop bits, where  $N=1, 2, \text{etc.}$  If a break character is to be transmitted then the TXBRK bit must be first set by the application program, and



then cleared to generate the stop bits. Transmitting a break character will not generate a transmit interrupt. Note that a break condition length is at least 13 bits long. If the TXBRK bit is continually kept at a logic high level then the transmitter circuitry will transmit continuous break characters. After the application program has cleared the TXBRK bit, the transmitter will finish transmitting the last break character and subsequently send out one or two stop bits. The automatic logic highs at the end of the last break character will ensure that the start bit of the next frame is recognized.

## UART Receiver

The UART is capable of receiving word lengths of either 8 or 9 bits. If the BNO bit is set, the word length will be set to 9 bits with the MSB being stored in the RX8 bit of the UCR1 register. At the receiver core lies the Receive Serial Shift Register, commonly known as the RSR. The data which is received on the RX/TX external input pin is sent to the data recovery block. The data recovery block operating speed is 16 times that of the baud rate, while the main receive serial shifter operates at the baud rate. After the RX/TX pin is sampled for the stop bit, the received data in RSR is transferred to the receive data register, if the register is empty. The data which is received on the external RX/TX pin is sampled three times by a majority detect circuit to determine the logic level that has been placed onto the RX/TX pin. It should be noted that the RSR register, unlike many other registers, is not directly mapped into the Data Memory area and as such is not available to the application program for direct read/write operations.

## Receiving Data

When the UART receiver is receiving data, the data is serially shifted in on the external RX/TX pin, LSB first. In the read mode, the TXR\_RXR register forms a buffer between the internal bus and the receiver shift register. The TXR\_RXR register is a two-byte deep FIFO data buffer, where two bytes can be held in the FIFO while a third byte can continue to be received. Note that the application program must ensure that the data is read from TXR\_RXR before the third byte has been completely shifted in, otherwise this third byte will be discarded and an overrun error OERR will be subsequently indicated. The steps to initiate a data transfer can be summarized as follows:

- Make the correct selection of BNO, PRT and PREN bits to define the word length, parity type.
- Configure the BRG register to select the desired baud rate.
- Set the RXEN bit to ensure that the RX/TX pin is used as a UART receiver pin.

At this point the receiver will be enabled which will begin to look for a start bit.

When a character is received the following sequence of events will occur:

- The RXIF bit in the USR register will be set when the TXR\_RXR register has data available. There will be at most one more character available before an overrun error occurs.
- When the contents of the shift register have been transferred to the TXR\_RXR register, then if the RIE bit is set, an interrupt will be generated.
- If during reception, a frame error, noise error, parity error, or an overrun error has been detected, then the error flags can be set.

The RXIF bit can be cleared using the following software sequence:

1. A USR register access
2. A TXR\_RXR register read execution

### Receive Break

Any break character received by the UART will be managed as a framing error. The receiver will count and expect a certain number of bit times as specified by the values programmed into the BNO bit plus one stop bit. If the break is much longer than 13 bit times, the reception will be considered as complete after the number of bit times specified by BNO plus one stop bit. The RXIF bit is set, FERR is set, zeros are loaded into the receive data register, interrupts are generated if appropriate and the RIDLE bit is set. If a long break signal has been detected and the receiver has received a start bit, the data bits and the invalid stop bit, which sets the FERR flag, the receiver must wait for a valid stop bit before looking for the next start bit. The receiver will not make the assumption that the break condition on the line is the next start bit. A break is regarded as a character that contains only zeros with the FERR flag set. The break character will be loaded into the buffer and no further data will be received until stop bits are received. It should be noted that the RIDLE read only flag will go high when the stop bits have not yet been received. The reception of a break character on the UART registers will result in the following:

- The framing error flag, FERR, will be set.
- The receive data register, TXR\_RXR, will be cleared.
- The OERR, NF, PERR, RIDLE or RXIF flags will possibly be set.

### Idle Status

When the receiver is reading data, which means it will be in between the detection of a start bit and the reading of a stop bit, the receiver status flag in the USR register, otherwise known as the RIDLE flag, will have a zero value. In between the reception of a stop bit and the detection of the next start bit, the RIDLE flag will have a high value, which indicates the receiver is in an idle condition.

### Receiver Interrupt

The read only receive interrupt flag RXIF in the USR register is set by an edge generated by the receiver. An interrupt is generated if RIE=1, when a word is transferred from the Receive Shift Register, RSR, to the Receive Data Register, TXR\_RXR. An overrun error can also generate an interrupt if RIE=1.

## Managing Receiver Errors

Several types of reception errors can occur within the UART module, the following section describes the various types and how they are managed by the UART.

### Overrun Error – OERR

The TXR\_RXR register is composed of a two-byte deep FIFO data buffer, where two bytes can be held in the FIFO register, while a third byte can continue to be received. Before this third byte has been entirely shifted in, the data should be read from the TXR\_RXR register. If this is not done, the overrun error flag OERR will be consequently indicated.

In the event of an overrun error occurring, the following will happen:

- The OERR flag in the USR register will be set.
- The TXR\_RXR contents will not be lost.
- The shift register will be overwritten.
- An interrupt will be generated if the RIE bit is set.

The OERR flag can be cleared by an access to the USR register followed by a read to the TXR\_RXR register.

### Noise Error – NF

Over-sampling is used for data recovery to identify valid incoming data and noise. If noise is detected within a frame the following will occur:

- The read only noise flag, NF, in the USR register will be set on the rising edge of the RXIF bit.
- Data will be transferred from the Shift register to the TXR\_RXR register.
- No interrupt will be generated. However this bit rises at the same time as the RXIF bit which itself generates an interrupt.

Note that the NF flag is reset by a USR register read operation followed by a TXR\_RXR register read operation.

### Framing Error – FERR

The read only framing error flag, FERR, in the USR register, is set if a zero is detected instead of stop bits. If two stop bits are selected, only first stop bit is detected, it must be high. If first stop bit is low, the FERR flag will be set. The FERR flag is buffered along with the receive data and is cleared in any reset.

### Parity Error – PERR

The read only parity error flag, PERR, in the USR register, is set if the parity of the received word is incorrect. This error flag is only applicable if the parity is enabled, PREN=1, and if the parity type, odd or even is selected. The read only PERR flag is buffered along with the receive data bytes. It is cleared on any reset, it should be noted that the flags, FERR and PERR, in the USR register are buffered along with the corresponding word and should be read before reading the data word.

## UART Interrupt Structure

Several individual UART conditions can generate a UART interrupt. When these conditions exist, a low pulse will be generated to get the attention of the microcontroller. These conditions are a transmitter data register empty, transmitter idle, receiver data available, receiver overrun, address detect and an RX/TX pin wake-up. When any of these conditions are created, if the global interrupt enable bit and its corresponding interrupt control bit are enabled and the stack is not full, the program will jump to its corresponding interrupt vector where it can be serviced before returning to the main program. Four of these conditions have the corresponding USR register flags which will generate a UART interrupt if its associated interrupt enable control bit in the UCR2 register is set. The two transmitter interrupt conditions have their own corresponding enable control bits, while the two receiver interrupt conditions have a shared enable control bit. These enable bits can be used to mask out individual UART interrupt sources.

The address detect condition, which is also a UART interrupt source, does not have an associated flag, but will generate a UART interrupt when an address detect condition occurs if its function is enabled by setting the ADDEN bit in the UCR2 register. An RX/TX pin wake-up, which is also a UART interrupt source, does not have an associated flag, but will generate a UART interrupt if the UART clock ( $f_{RT}$ ) source is switched off and the WAKE and RIE bits in the UCR2 register are set when a falling edge on the RX/TX pin occurs. Note that in the event of an RX/TX wake-up interrupt occurring, there will be a certain period of delay, commonly known as the System Start-up Time, for the oscillator to restart and stabilize before the system resumes normal operation.

Note that the USR register flags are read only and cannot be cleared or set by the application program, neither will they be cleared when the program jumps to the corresponding interrupt servicing routine, as is the case for some of the other interrupts. The flags will be cleared automatically when certain actions are taken by the UART, the details of which are given in the UART register section. The overall UART interrupt can be disabled or enabled by the related



interrupt enable control bits in the interrupt control registers of the microcontroller to decide whether the interrupt requested by the UART module is masked out or allowed.

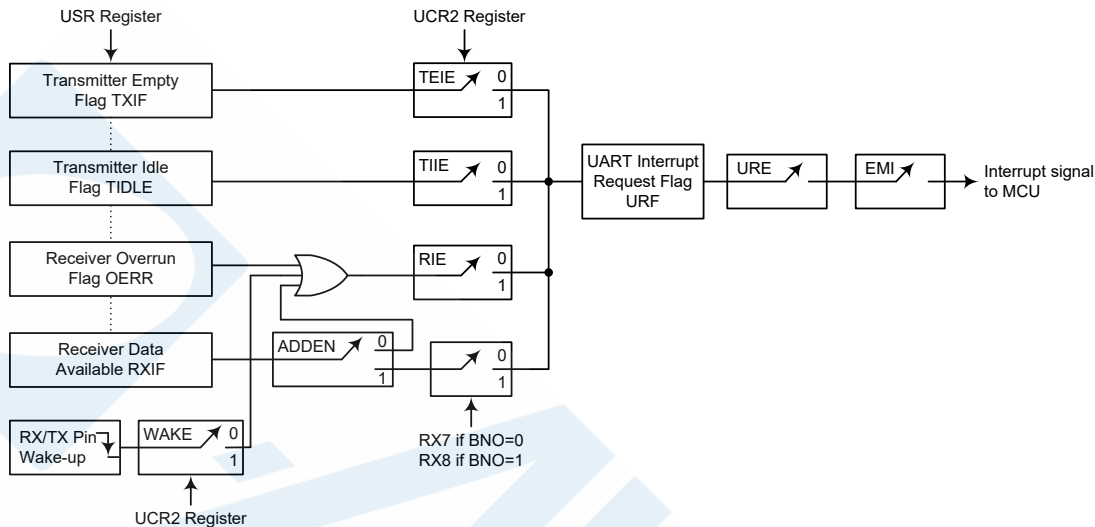

UART Interrupt Structure

### Address Detect Mode

Setting the Address Detect Mode bit, ADDEN, in the UCR2 register, enables this special mode. If this bit is enabled then an additional qualifier will be placed on the generation of a Receiver Data Available interrupt, which is requested by the RXIF flag. If the ADDEN bit is enabled, then when data is available, an interrupt request will only be generated if the highest received bit has a high value. Note that the URE and EMI interrupt enable bits must also be enabled for correct interrupt generation. This highest address bit is the 9th bit if BNO=1 or the 8th bit if BNO=0. If this bit is high, then the received word will be defined as an address rather than data. A Data Available interrupt will be generated every time the last bit of the received word is set. If the ADDEN bit is not enabled, then a Receiver Data Available interrupt will be generated each time the RXIF flag is set, irrespective of the data last bit status. The address detect mode and parity enable are mutually exclusive functions. Therefore if the address detect mode is enabled, then to ensure correct operation, the parity function should be disabled by resetting the parity enable bit PREN to zero.

ADDEN	9th bit if BNO=1, 8th bit if BNO=0	UART Interrupt Generated
0	0	√
	1	√
1	0	×
	1	√

ADDEN Bit Function

### UART Power Down and Wake-up

When the UART clock ( $f_{H1}$ ) is off, the UART will cease to function, and all clock sources to the module are shutdown. If the UART clock ( $f_{H1}$ ) is off while a transmission is still in progress, then the transmission will be paused until the UART clock source derived from the microcontroller is activated. In a similar way, if the MCU enters the IDLE or SLEEP Mode while receiving data, then the reception of data will likewise be paused. When the MCU enters the IDLE or SLEEP Mode, note

that the USR, UCR1, UCR2, UCR3, TXR\_RXR as well as the BRG register will not be affected. It is recommended to make sure first that the UART data transmission or reception has been finished before the microcontroller enters the IDLE or SLEEP mode.

The UART function contains a receiver RX/TX pin wake-up function, which is enabled or disabled by the WAKE bit in the UCR2 register. If this bit, along with the UART enable bit, UARTEN, the receiver enable bit, RXEN and the receiver interrupt bit, RIE, are all set when the UART clock ( $f_{rt}$ ) is off, then a falling edge on the RX/TX pin will trigger an RX/TX pin wake-up UART interrupt. Note that as it takes certain system clock cycles after a wake-up, before normal microcontroller operation resumes, any data received during this time on the RX/TX pin will be ignored.

For a UART wake-up interrupt to occur, in addition to the bits for the wake-up being set, the global interrupt enable bit, EMI, and the UART interrupt enable bit, URE, must be set. If the EMI and URE bits are not set then only a wake-up event will occur and no interrupt will be generated. Note also that as it takes certain system clock cycles after a wake-up before normal microcontroller resumes, the UART interrupt will not be generated until after this time has elapsed.

## Interrupts

Interrupts are an important part of any microcontroller system. When an external event or an internal function such as a Timer Module or an A/D converter requires microcontroller attention, their corresponding interrupt will enforce a temporary suspension of the main program allowing the microcontroller to direct attention to their respective needs. The device contains several external interrupt and internal interrupt functions. The external interrupt is generated by the action of the external INT pin, while the internal interrupts are generated by various internal functions such as the TM, Time Bases, UART and the A/D converter, etc.

### Interrupt Registers

Overall interrupt control, which basically means the setting of request flags when certain microcontroller conditions occur and the setting of interrupt enable bits by the application program, is controlled by a series of registers, located in the Special Purpose Data Memory, as shown in the accompanying table. The number of registers falls into three categories. The first is the INTC0~INTC1 registers which setup the primary interrupts, the second is the MFI register which setups the Multi-function interrupts. Finally there is an INTEG register to setup the external interrupt trigger edge type.

Each register contains a number of enable bits to enable or disable individual registers as well as interrupt flags to indicate the presence of an interrupt request. The naming convention of these follows a specific pattern. First is listed an abbreviated interrupt type, then the (optional) number of that interrupt followed by either an “E” for enable/disable bit or “F” for request flag.

Function	Enable Bit	Request Flag	Notes
Global	EMI	—	—
INT Pin	INTE	INTF	—
Time Base	TBnE	TBnF	n=0~1
Multi-function	MFE	MFF	—
A/D Converter	ADE	ADF	—
UART	URE	URF	—
CTM	CTMPE	CTMPF	—
	CTMAE	CTMAF	—

**Interrupt Register Bit Naming Conventions**

Register Name	Bit							
	7	6	5	4	3	2	1	0
INTEG	—	—	—	—	—	—	INTS1	INTS0
INTC0	—	TB0F	URF	INTF	TB0E	URE	INTE	EMI
INTC1	—	TB1F	ADF	MFF	—	TB1E	ADE	MFE
MFI	—	—	CTMAF	CTMPF	—	—	CTMAE	CTMPE

Interrupt Register List

• **INTEG Register**

Bit	7	6	5	4	3	2	1	0
Name	—	—	—	—	—	—	INTS1	INTS0
R/W	—	—	—	—	—	—	R/W	R/W
POR	—	—	—	—	—	—	0	0

- Bit 7~2 Unimplemented, read as “0”
- Bit 1~0 **INTS1~INTS0**: Interrupt edge control for INT pin  
 00: Disable  
 01: Rising edge  
 10: Falling edge  
 11: Rising and falling edges

• **INTC0 Register**

Bit	7	6	5	4	3	2	1	0
Name	—	TB0F	URF	INTF	TB0E	URE	INTE	EMI
R/W	—	R/W	R/W	R/W	R/W	R/W	R/W	R/W
POR	—	0	0	0	0	0	0	0

- Bit 7 Unimplemented, read as “0”
- Bit 6 **TB0F**: Time Base 0 interrupt request flag  
 0: No request  
 1: Interrupt request
- Bit 5 **URF**: UART interrupt request flag  
 0: No request  
 1: Interrupt request
- Bit 4 **INTF**: INT interrupt request flag  
 0: No request  
 1: Interrupt request
- Bit 3 **TB0E**: Time Base 0 interrupt control  
 0: Disable  
 1: Enable
- Bit 2 **URE**: UART interrupt control  
 0: Disable  
 1: Enable
- Bit 1 **INTE**: INT interrupt control  
 0: Disable  
 1: Enable
- Bit 0 **EMI**: Global interrupt control  
 0: Disable  
 1: Enable

• **INTC1 Register**

Bit	7	6	5	4	3	2	1	0
Name	—	TB1F	ADF	MFF	—	TB1E	ADE	MFE
R/W	—	R/W	R/W	R/W	—	R/W	R/W	R/W
POR	—	0	0	0	—	0	0	0

- Bit 7 Unimplemented, read as “0”
- Bit 6 **TB1F**: Time Base 1 interrupt request flag  
0: No request  
1: Interrupt request
- Bit 5 **ADF**: A/D Converter interrupt request flag  
0: No request  
1: Interrupt request
- Bit 4 **MFF**: Multi-function interrupt request flag  
0: No request  
1: Interrupt request
- Bit 3 Unimplemented, read as “0”
- Bit 2 **TB1E**: Time Base 1 interrupt control  
0: Disable  
1: Enable
- Bit 1 **ADE**: A/D Converter interrupt control  
0: Disable  
1: Enable
- Bit 0 **MFE**: Multi-function interrupt control  
0: Disable  
1: Enable

• **MFI Register**

Bit	7	6	5	4	3	2	1	0
Name	—	—	CTMAF	CTMPF	—	—	CTMAE	CTMPE
R/W	—	—	R/W	R/W	—	—	R/W	R/W
POR	—	—	0	0	—	—	0	0

- Bit 7~6 Unimplemented, read as “0”
- Bit 5 **CTMAF**: CTM Comparator A match interrupt request flag  
0: No request  
1: Interrupt request
- Bit 4 **CTMPF**: CTM Comparator P match interrupt request flag  
0: No request  
1: Interrupt request
- Bit 3~2 Unimplemented, read as “0”
- Bit 1 **CTMAE**: CTM Comparator A match interrupt control  
0: Disable  
1: Enable
- Bit 0 **CTMPE**: CTM Comparator P match interrupt control  
0: Disable  
1: Enable

### Interrupt Operation

When the conditions for an interrupt event occur, such as a TM Comparator P or Comparator A match or A/D conversion completion etc., the relevant interrupt request flag will be set. Whether the request flag actually generates a program jump to the relevant interrupt vector is determined by the condition of the interrupt enable bit. If the enable bit is set high then the program will jump to its relevant vector; if the enable bit is zero then although the interrupt request flag is set an actual interrupt will not be generated and the program will not jump to the relevant interrupt vector. The global interrupt enable bit, if cleared to zero, will disable all interrupts.

When an interrupt is generated, the Program Counter, which stores the address of the next instruction to be executed, will be transferred onto the stack. The Program Counter will then be loaded with a new address which will be the value of the corresponding interrupt vector. The microcontroller will then fetch its next instruction from this interrupt vector. The instruction at this vector will usually be a “JMP” which will jump to another section of program which is known as the interrupt service routine. Here is located the code to control the appropriate interrupt. The interrupt service routine must be terminated with a “RETI”, which retrieves the original Program Counter address from the stack and allows the microcontroller to continue with normal execution at the point where the interrupt occurred.

The various interrupt enable bits, together with their associated request flags, are shown in the accompanying diagrams with their order of priority. Some interrupt sources have their own individual vector while others share the same multi-function interrupt vector. Once an interrupt subroutine is serviced, all the other interrupts will be blocked, as the global interrupt enable bit, EMI bit will be cleared automatically. This will prevent any further interrupt nesting from occurring. However, if other interrupt requests occur during this interval, although the interrupt will not be immediately serviced, the request flag will still be recorded.

If an interrupt requires immediate servicing while the program is already in another interrupt service routine, the EMI bit should be set after entering the routine, to allow interrupt nesting. If the stack is full, the interrupt request will not be acknowledged, even if the related interrupt is enabled, until the Stack Pointer is decremented. If immediate service is desired, the stack must be prevented from becoming full. In case of simultaneous requests, the accompanying diagram shows the priority that is applied. All of the interrupt request flags when set will wake up the device if it is in SLEEP or IDLE Mode, however to prevent a wake-up from occurring the corresponding flag should be set before the device is in SLEEP or IDLE Mode.

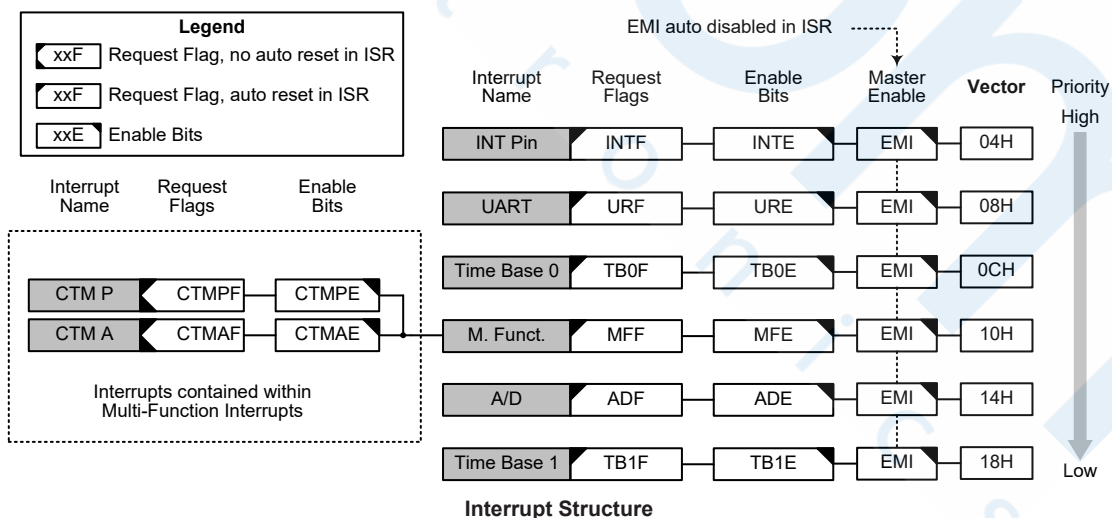

### External Interrupt

The external interrupt is controlled by signal transitions on the INT pin. An external interrupt request will take place when the external interrupt request flag, INTF, is set, which will occur when a transition, whose type is chosen by the edge selection bits, appears on the external interrupt pin. To allow the program to branch to its interrupt vector address, the global interrupt enable bit, EMI, and the external interrupt enable bit, INTE, must first be set. Additionally, the correct interrupt edge type must be selected using the INTEG register to enable the external interrupt function and to choose the trigger edge type. As the external interrupt pin is pin-shared with I/O pins, it can only be configured as external interrupt pin if its external interrupt enable bit in the corresponding interrupt register has been set and the external interrupt pin is selected by the corresponding pin-shared function selection bits. The pin must also be setup as an input by setting the corresponding bit in the port control register. When the interrupt is enabled, the stack is not full and the correct transition type appears on the external interrupt pin, a subroutine call to the external interrupt vector, will take place. When the interrupt is serviced, the external interrupt request flag, INTF, will be automatically reset and the EMI bit will be automatically cleared to disable other interrupts. Note that pull-high resistor selection on the external interrupt pin will remain valid even if the pin is used as an external interrupt input.

The INTEG register is used to select the type of active edge that will trigger the external interrupt. A choice of either rising or falling or both edge types can be chosen to trigger an external interrupt. Note that the INTEG register can also be used to disable the external interrupt function.

### Time Base Interrupts

The function of the Time Base Interrupts is to provide regular time signals in the form of an internal interrupt. They are controlled by the overflow signals from their respective timer functions. When these happens their respective interrupt request flags, TB0F or TB1F will be set. To allow the program to branch to their respective interrupt vector addresses, the global interrupt enable bit, EMI and Time Base enable bits, TB0E or TB1E, must first be set. When the interrupt is enabled, the stack is not full and the Time Base overflows, a subroutine call to their respective vector locations will take place. When the interrupt is serviced, the respective interrupt request flag, TB0F or TB1F, will be automatically reset and the EMI bit will be cleared to disable other interrupts.

The purpose of the Time Base Interrupt is to provide an interrupt signal at fixed time periods. Its clock source,  $f_{PSC}$ , originates from the internal clock source  $f_{SYS}$ ,  $f_{SYS}/4$  or  $f_{SUB}$  and then passes through a divider, the division ratio of which is selected by programming the appropriate bits in the TB0C and TB1C registers to obtain longer interrupt periods whose value ranges. The clock source that generates  $f_{PSC}$ , which in turn controls the Time Base interrupt period, is selected using the CLKSEL1~CLKSEL0 bits in the PSCR register.

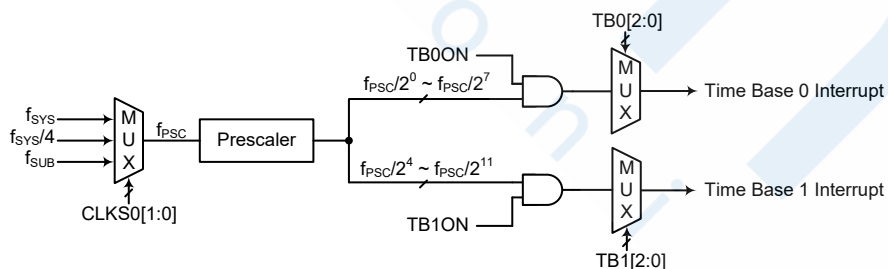

**Time Base Interrupts**

• PSCR Register

Bit	7	6	5	4	3	2	1	0
Name	—	—	—	—	—	—	CLKSEL1	CLKSEL0
R/W	—	—	—	—	—	—	R/W	R/W
POR	—	—	—	—	—	—	0	0

Bit 7~2 Unimplemented, read as “0”

Bit 1~0 **CLKSEL1~CLKSEL0**: Prescaler clock source selection

00:  $f_{SYS}$

01:  $f_{SYS}/4$

1x:  $f_{SUB}$

• TB0C Register

Bit	7	6	5	4	3	2	1	0
Name	TB0ON	—	—	—	—	TB02	TB01	TB00
R/W	R/W	—	—	—	—	R/W	R/W	R/W
POR	0	—	—	—	—	0	0	0

Bit 7 **TB0ON**: Time Base 0 Control

0: Disable

1: Enable

Bit 6~3 Unimplemented, read as “0”

Bit 2~0 **TB02~TB00**: Select Time Base 0 Time-out Period

000:  $2^0/f_{PSC}$

001:  $2^1/f_{PSC}$

010:  $2^2/f_{PSC}$

011:  $2^3/f_{PSC}$

100:  $2^4/f_{PSC}$

101:  $2^5/f_{PSC}$

110:  $2^6/f_{PSC}$

111:  $2^7/f_{PSC}$

• TB1C Register

Bit	7	6	5	4	3	2	1	0
Name	TB1ON	—	—	—	—	TB12	TB11	TB10
R/W	R/W	—	—	—	—	R/W	R/W	R/W
POR	0	—	—	—	—	0	0	0

Bit 7 **TB1ON**: Time Base 1 Control

0: Disable

1: Enable

Bit 6~3 Unimplemented, read as “0”

Bit 2~0 **TB12~TB10**: Select Time Base 1 Time-out Period

000:  $2^4/f_{PSC}$

001:  $2^5/f_{PSC}$

010:  $2^6/f_{PSC}$

011:  $2^7/f_{PSC}$

100:  $2^8/f_{PSC}$

101:  $2^9/f_{PSC}$

110:  $2^{10}/f_{PSC}$

111:  $2^{11}/f_{PSC}$



## Multi-function Interrupt

Within the device there is one Multi-function interrupt. Unlike the other independent interrupts, this interrupt has no independent source, but rather is formed from other existing interrupt sources, namely the TM Interrupts.

A Multi-function interrupt request will take place when the Multi-function interrupt request flag, MFF is set. The Multi-function interrupt flag will be set when any of its included functions generate an interrupt request flag. To allow the program to branch to its interrupt vector address, when the Multi-function interrupt is enabled and the stack is not full, and either one of the interrupts contained within the Multi-function interrupt occurs, a subroutine call to the Multi-function interrupt vector will take place. When the interrupt is serviced, the Multi-Function request flag will be automatically reset and the EMI bit will be automatically cleared to disable other interrupts.

However, it must be noted that, although the Multi-function Interrupt flag will be automatically reset when the interrupt is serviced, the request flags from the original source of the Multi-function interrupt will not be automatically reset and must be manually reset by the application program.

## TM Interrupts

The Compact Type TM has two interrupts, one comes from the comparator A match situation and the other comes from the comparator P match situation. Both the TM interrupts are contained within the Multi-function Interrupt. There are two interrupt request flags, CTMPF and CTMAF, and two enable control bits, CTMPE and CTMAE. A TM interrupt request will take place when any of the TM request flags are set, a situation which occurs when a TM comparator P or A match situation happens.

To allow the program to branch to its respective interrupt vector address, the global interrupt enable bit, EMI, respective TM Interrupt enable bit, and the Multi-function Interrupt enable bit, MFE, must first be set. When the interrupt is enabled, the stack is not full and a TM comparator match situation occurs, a subroutine call to the Multi-function Interrupt vector location, will take place. When the TM interrupt is serviced, the EMI bit will be automatically cleared to disable other interrupts, however only the MFF flag will be automatically cleared. As the TM interrupt request flags will not be automatically cleared, they have to be cleared by the application program.

## A/D Converter Interrupt

An A/D Converter Interrupt request will take place when the A/D Converter Interrupt request flag, ADF, is set, which occurs when the A/D conversion process finishes. To allow the program to branch to its interrupt vector address, the global interrupt enable bit, EMI, and A/D Interrupt enable bit, ADE, must first be set. When the interrupt is enabled, the stack is not full and the A/D conversion process has ended, a subroutine call to the A/D Interrupt vector, will take place. When the A/D Converter Interrupt is serviced, the A/D Interrupt flag, ADF, will be automatically cleared. The EMI bit will also be automatically cleared to disable other interrupts.

## UART Interrupt

Several individual UART conditions can generate a UART interrupt. When one of these conditions occurs, an interrupt pulse will be generated to get the attention of the microcontroller. These conditions are a transmitter data register empty, transmitter idle, receiver data available, receiver overrun, address detect and an RX/TX pin wake-up. To allow the program to branch to the corresponding interrupt vector address, the global interrupt enable bit, EMI, and the UART interrupt enable bit, URE, must first be set. When the interrupt is enabled, the stack is not full and any of these conditions are created, a subroutine call to the UART Interrupt vector, will take place. When the UART Interrupt is serviced, the UART Interrupt flag, URF, will be automatically cleared. The



EMI bit will also be automatically cleared to disable other interrupts. However, the USR register flags will only be cleared when certain actions are taken by the UART, the details of which are given in the UART section.

### **Interrupt Wake-up Function**

Each of the interrupt functions has the capability of waking up the microcontroller when in the SLEEP or IDLE Mode. A wake-up is generated when an interrupt request flag changes from low to high and is independent of whether the interrupt is enabled or not. Therefore, even though the device is in the SLEEP or IDLE Mode and its system oscillator stopped, situations such as external edge transitions on the external interrupt pin may cause its interrupt flag to be set high and consequently generate an interrupt. Care must therefore be taken if spurious wake-up situations are to be avoided. If an interrupt wake-up function is to be disabled then the corresponding interrupt request flag should be set high before the device enters the SLEEP or IDLE Mode. The interrupt enable bits have no effect on the interrupt wake-up function.

### **Programming Considerations**

By disabling the relevant interrupt enable bits, a requested interrupt can be prevented from being serviced, however, once an interrupt request flag is set, it will remain in this condition in the interrupt register until the corresponding interrupt is serviced or until the request flag is cleared by the application program.

Where a certain interrupt is contained within a Multi-function interrupt, then when the interrupt service routine is executed, as only the Multi-function interrupt request flag, MFF, will be automatically cleared, the individual request flag for the function needs to be cleared by the application program.

It is recommended that programs do not use the “CALL” instruction within the interrupt service subroutine. Interrupts often occur in an unpredictable manner or need to be serviced immediately. If only one stack is left and the interrupt is not well controlled, the original control sequence will be damaged once a CALL subroutine is executed in the interrupt subroutine.

Every interrupt has the capability of waking up the microcontroller when it is in the SLEEP or IDLE Mode, the wake up being generated when the interrupt request flag changes from low to high. If it is required to prevent a certain interrupt from waking up the microcontroller then its respective request flag should be first set high before enter SLEEP or IDLE Mode.

As only the Program Counter is pushed onto the stack, then when the interrupt is serviced, if the contents of the accumulator, status register or other registers are altered by the interrupt service program, their contents should be saved to the memory at the beginning of the interrupt service routine.

To return from an interrupt subroutine, either an RET or RETI instruction may be executed. The RETI instruction in addition to executing a return to the main program also automatically sets the EMI bit high to allow further interrupts. The RET instruction however only executes a return to the main program leaving the EMI bit in its present zero state and therefore disabling the execution of further interrupts.

## Application Descriptions

### Introduction

According to the battery current condition, the charger can use a Buck circuit to implement charger management. The battery charging contains constant voltage Mode and Constant current Mode. The HT45F5Q-2A device is specifically designed for battery charger applications. The above-mentioned function control can be implemented by the integrated battery charger management, these are described below.

### Functional Description

#### Operating Principle

The device contains a battery charge module which consists of three operational amplifier (OPA0~OPA2) functions, a 14-bit D/A converter (DAC0) and a 12-bit D/A converter (DAC1) functions. The open drain OPA0~OPA1 and DAC0~DAC1 are used for constant current and constant voltage signal control. The OPA output can directly drive the photo-coupler, which makes the PWM IC on the primary side can implement output power adjustment, shown in the figure below. The internal 20 times amplifier OPA2 is used to amplify the charge current signal, thus increasing the current resolution and reducing the detecting resistance power consumption. The constant voltage mode, constant current mode and constant current and constant voltage resolution increasing method are described as follows.

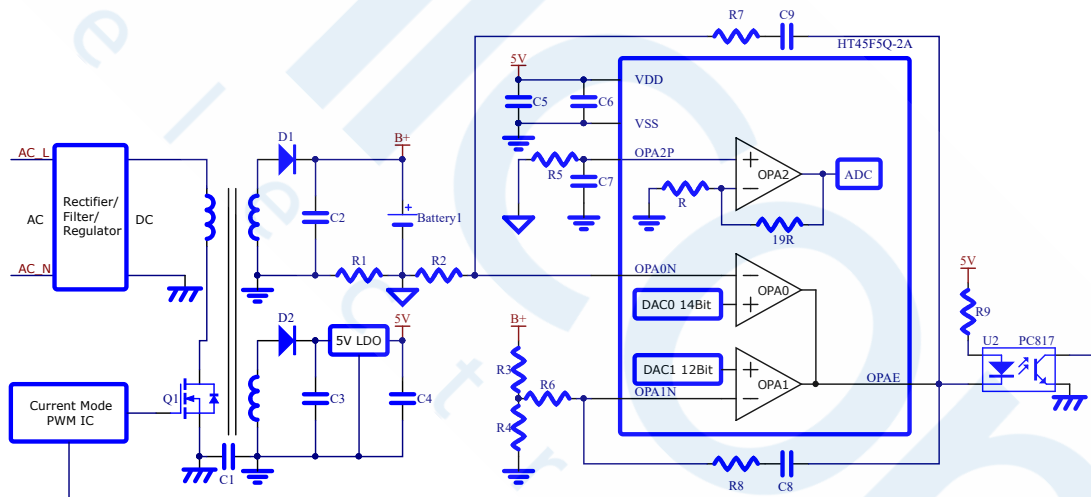

Battery Charge Module

#### Constant Current Mode Description

Constant current charging means that the charge current will remain at a constant value no matter how the battery internal resistance changes. The principle is that the charge current flows through the detecting resistor R1 and in turn generates a voltage, which will be input to the OPA0 negative terminal through the OPA0N pin. The difference between the OPA0N voltage and the D/A converter voltage is amplified and then output on the OPAE pin. This output will be sent to the PWM IC via a photo-coupler. If the OPA0N voltage is lower than the DAC0 voltage, the PWM IC will increase the PWM duty cycle and vice versa.

Note: The DA0H and DA0L registers are used to set the maximum current threshold.

**Constant Voltage Mode Description**

Constant voltage charging means that the charge voltage will remain at a constant value no matter how the battery internal resistance changes. The principle is that the charge voltage B+ is divided by R3 and R4 resistors and then supplied to the OPA1 negative terminal through the OPA1N pin. The difference between the OPA1N voltage and the D/A converter voltage is amplified and then output on the OPAE pin. This output will be sent to the PWM IC via a photo-coupler. If the OPA1N voltage is lower than the DAC1 voltage, the PWM IC will increase the PWM duty cycle and vice versa.

Note: The DA1H and DA1L registers are used to set the maximum voltage threshold.

**Improving the Constant Current and Constant Voltage Resolution**

If the internal 14/12-bit D/A Converter resolution is not high enough, the OPA0 and OPA1 positive terminals can be supplied by an external divider resistor to increase the voltage and current resolution.

**Hardware Circuit**

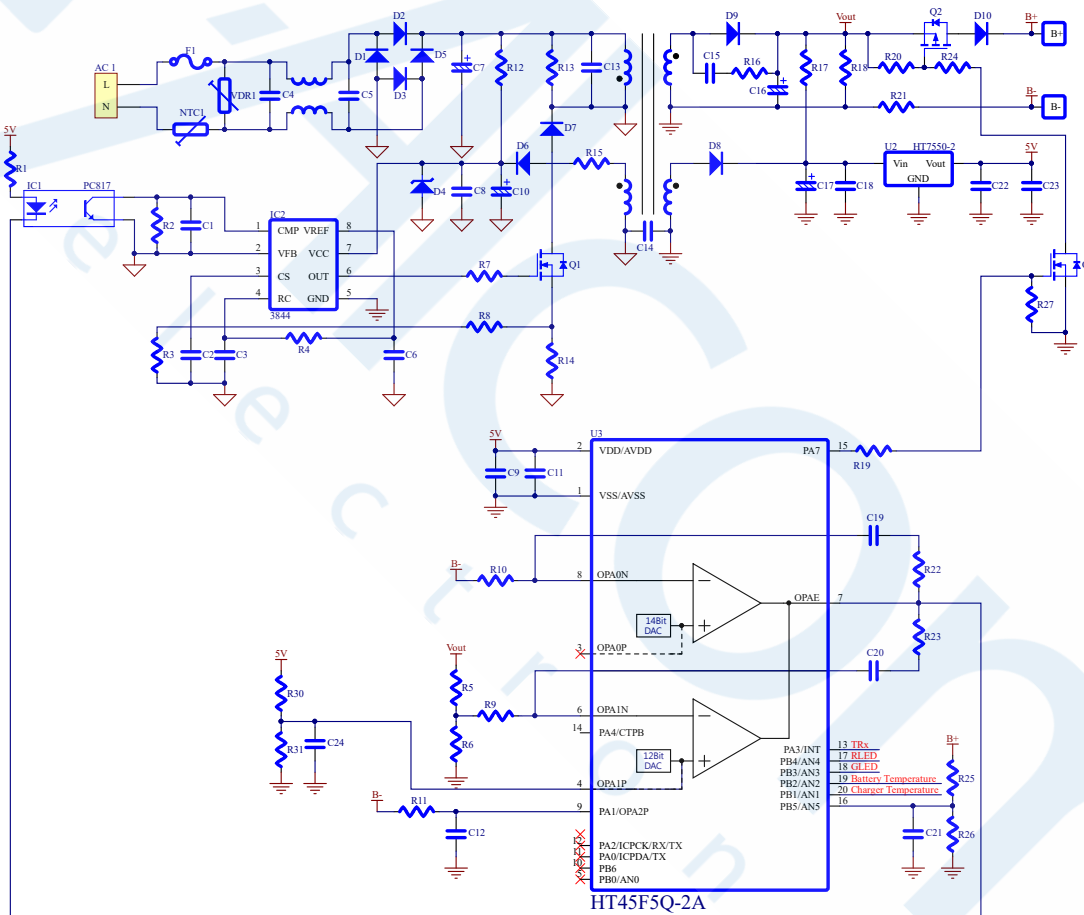

**Charger Application Circuit**

## Instruction Set

### Introduction

Central to the successful operation of any microcontroller is its instruction set, which is a set of program instruction codes that directs the microcontroller to perform certain operations. In the case of Holtek microcontroller, a comprehensive and flexible set of over 60 instructions is provided to enable programmers to implement their application with the minimum of programming overheads.

For easier understanding of the various instruction codes, they have been subdivided into several functional groupings.

### Instruction Timing

Most instructions are implemented within one instruction cycle. The exceptions to this are branch, call, or table read instructions where two instruction cycles are required. One instruction cycle is equal to 4 system clock cycles, therefore in the case of an 8MHz system oscillator, most instructions would be implemented within 0.5 $\mu$ s and branch or call instructions would be implemented within 1 $\mu$ s. Although instructions which require one more cycle to implement are generally limited to the JMP, CALL, RET, RETI and table read instructions, it is important to realize that any other instructions which involve manipulation of the Program Counter Low register or PCL will also take one more cycle to implement. As instructions which change the contents of the PCL will imply a direct jump to that new address, one more cycle will be required. Examples of such instructions would be "CLR PCL" or "MOV PCL, A". For the case of skip instructions, it must be noted that if the result of the comparison involves a skip operation then this will also take one more cycle, if no skip is involved then only one cycle is required.

### Moving and Transferring Data

The transfer of data within the microcontroller program is one of the most frequently used operations. Making use of three kinds of MOV instructions, data can be transferred from registers to the Accumulator and vice-versa as well as being able to move specific immediate data directly into the Accumulator. One of the most important data transfer applications is to receive data from the input ports and transfer data to the output ports.

### Arithmetic Operations

The ability to perform certain arithmetic operations and data manipulation is a necessary feature of most microcontroller applications. Within the Holtek microcontroller instruction set are a range of add and subtract instruction mnemonics to enable the necessary arithmetic to be carried out. Care must be taken to ensure correct handling of carry and borrow data when results exceed 255 for addition and less than 0 for subtraction. The increment and decrement instructions INC, INCA, DEC and DECA provide a simple means of increasing or decreasing by a value of one of the values in the destination specified.

## Logical and Rotate Operation

The standard logical operations such as AND, OR, XOR and CPL all have their own instruction within the Holtek microcontroller instruction set. As with the case of most instructions involving data manipulation, data must pass through the Accumulator which may involve additional programming steps. In all logical data operations, the zero flag may be set if the result of the operation is zero. Another form of logical data manipulation comes from the rotate instructions such as RR, RL, RRC and RLC which provide a simple means of rotating one bit right or left. Different rotate instructions exist depending on program requirements. Rotate instructions are useful for serial port programming applications where data can be rotated from an internal register into the Carry bit from where it can be examined and the necessary serial bit set high or low. Another application which rotate data operations are used is to implement multiplication and division calculations.

## Branches and Control Transfer

Program branching takes the form of either jumps to specified locations using the JMP instruction or to a subroutine using the CALL instruction. They differ in the sense that in the case of a subroutine call, the program must return to the instruction immediately when the subroutine has been carried out. This is done by placing a return instruction "RET" in the subroutine which will cause the program to jump back to the address right after the CALL instruction. In the case of a JMP instruction, the program simply jumps to the desired location. There is no requirement to jump back to the original jumping off point as in the case of the CALL instruction. One special and extremely useful set of branch instructions are the conditional branches. Here a decision is first made regarding the condition of a certain data memory or individual bits. Depending upon the conditions, the program will continue with the next instruction or skip over it and jump to the following instruction. These instructions are the key to decision making and branching within the program perhaps determined by the condition of certain input switches or by the condition of internal data bits.

## Bit Operations

The ability to provide single bit operations on Data Memory is an extremely flexible feature of all Holtek microcontrollers. This feature is especially useful for output port bit programming where individual bits or port pins can be directly set high or low using either the "SET [m].i" or "CLR [m].i" instructions respectively. The feature removes the need for programmers to first read the 8-bit output port, manipulate the input data to ensure that other bits are not changed and then output the port with the correct new data. This read-modify-write process is taken care of automatically when these bit operation instructions are used.

## Table Read Operations

Data storage is normally implemented by using registers. However, when working with large amounts of fixed data, the volume involved often makes it inconvenient to store the fixed data in the Data Memory. To overcome this problem, Holtek microcontrollers allow an area of Program Memory to be set as a table where data can be directly stored. A set of easy to use instructions provides the means by which this fixed data can be referenced and retrieved from the Program Memory.

## Other Operations

In addition to the above functional instructions, a range of other instructions also exist such as the "HALT" instruction for Power-down operations and instructions to control the operation of the Watchdog Timer for reliable program operations under extreme electric or electromagnetic environments. For their relevant operations, refer to the functional related sections.

## Instruction Set Summary

The following table depicts a summary of the instruction set categorised according to function and can be consulted as a basic instruction reference using the following listed conventions.

### Table Conventions

x: Bits immediate data  
 m: Data Memory address  
 A: Accumulator  
 i: 0~7 number of bits  
 addr: Program memory address

Mnemonic	Description	Cycles	Flag Affected
<b>Arithmetic</b>			
ADD A,[m]	Add Data Memory to ACC	1	Z, C, AC, OV
ADDM A,[m]	Add ACC to Data Memory	1 <sup>Note</sup>	Z, C, AC, OV
ADD A,x	Add immediate data to ACC	1	Z, C, AC, OV
ADC A,[m]	Add Data Memory to ACC with Carry	1	Z, C, AC, OV
ADCM A,[m]	Add ACC to Data memory with Carry	1 <sup>Note</sup>	Z, C, AC, OV
SUB A,x	Subtract immediate data from the ACC	1	Z, C, AC, OV
SUB A,[m]	Subtract Data Memory from ACC	1	Z, C, AC, OV
SUBM A,[m]	Subtract Data Memory from ACC with result in Data Memory	1 <sup>Note</sup>	Z, C, AC, OV
SBC A,[m]	Subtract Data Memory from ACC with Carry	1	Z, C, AC, OV
SBCM A,[m]	Subtract Data Memory from ACC with Carry, result in Data Memory	1 <sup>Note</sup>	Z, C, AC, OV
DAA [m]	Decimal adjust ACC for Addition with result in Data Memory	1 <sup>Note</sup>	C
<b>Logic Operation</b>			
AND A,[m]	Logical AND Data Memory to ACC	1	Z
OR A,[m]	Logical OR Data Memory to ACC	1	Z
XOR A,[m]	Logical XOR Data Memory to ACC	1	Z
ANDM A,[m]	Logical AND ACC to Data Memory	1 <sup>Note</sup>	Z
ORM A,[m]	Logical OR ACC to Data Memory	1 <sup>Note</sup>	Z
XORM A,[m]	Logical XOR ACC to Data Memory	1 <sup>Note</sup>	Z
AND A,x	Logical AND immediate Data to ACC	1	Z
OR A,x	Logical OR immediate Data to ACC	1	Z
XOR A,x	Logical XOR immediate Data to ACC	1	Z
CPL [m]	Complement Data Memory	1 <sup>Note</sup>	Z
CPLA [m]	Complement Data Memory with result in ACC	1	Z
<b>Increment &amp; Decrement</b>			
INCA [m]	Increment Data Memory with result in ACC	1	Z
INC [m]	Increment Data Memory	1 <sup>Note</sup>	Z
DECA [m]	Decrement Data Memory with result in ACC	1	Z
DEC [m]	Decrement Data Memory	1 <sup>Note</sup>	Z
<b>Rotate</b>			
RRA [m]	Rotate Data Memory right with result in ACC	1	None
RR [m]	Rotate Data Memory right	1 <sup>Note</sup>	None
RRCA [m]	Rotate Data Memory right through Carry with result in ACC	1	C
RRC [m]	Rotate Data Memory right through Carry	1 <sup>Note</sup>	C
RLA [m]	Rotate Data Memory left with result in ACC	1	None
RL [m]	Rotate Data Memory left	1 <sup>Note</sup>	None
RLCA [m]	Rotate Data Memory left through Carry with result in ACC	1	C
RLC [m]	Rotate Data Memory left through Carry	1 <sup>Note</sup>	C

Mnemonic	Description	Cycles	Flag Affected
<b>Data Move</b>			
MOV A,[m]	Move Data Memory to ACC	1	None
MOV [m],A	Move ACC to Data Memory	1 <sup>Note</sup>	None
MOV A,x	Move immediate data to ACC	1	None
<b>Bit Operation</b>			
CLR [m].i	Clear bit of Data Memory	1 <sup>Note</sup>	None
SET [m].i	Set bit of Data Memory	1 <sup>Note</sup>	None
<b>Branch Operation</b>			
JMP addr	Jump unconditionally	2	None
SZ [m]	Skip if Data Memory is zero	1 <sup>Note</sup>	None
SZA [m]	Skip if Data Memory is zero with data movement to ACC	1 <sup>Note</sup>	None
SZ [m].i	Skip if bit i of Data Memory is zero	1 <sup>Note</sup>	None
SNZ [m].i	Skip if bit i of Data Memory is not zero	1 <sup>Note</sup>	None
SIZ [m]	Skip if increment Data Memory is zero	1 <sup>Note</sup>	None
SDZ [m]	Skip if decrement Data Memory is zero	1 <sup>Note</sup>	None
SIZA [m]	Skip if increment Data Memory is zero with result in ACC	1 <sup>Note</sup>	None
SDZA [m]	Skip if decrement Data Memory is zero with result in ACC	1 <sup>Note</sup>	None
CALL addr	Subroutine call	2	None
RET	Return from subroutine	2	None
RET A,x	Return from subroutine and load immediate data to ACC	2	None
RETI	Return from interrupt	2	None
<b>Table Read Operation</b>			
TABRD [m]	Read table (specific page or current page) to TBLH and Data Memory	2 <sup>Note</sup>	None
TABRDL [m]	Read table (last page) to TBLH and Data Memory	2 <sup>Note</sup>	None
<b>Miscellaneous</b>			
NOP	No operation	1	None
CLR [m]	Clear Data Memory	1 <sup>Note</sup>	None
SET [m]	Set Data Memory	1 <sup>Note</sup>	None
CLR WDT	Clear Watchdog Timer	1	TO, PDF
SWAP [m]	Swap nibbles of Data Memory	1 <sup>Note</sup>	None
SWAPA [m]	Swap nibbles of Data Memory with result in ACC	1	None
HALT	Enter power down mode	1	TO, PDF

Note: 1. For skip instructions, if the result of the comparison involves a skip then two cycles are required, if no skip takes place only one cycle is required.

2. Any instruction which changes the contents of the PCL will also require 2 cycles for execution.



## Instruction Definition

<b>ADC A,[m]</b>	Add Data Memory to ACC with Carry
Description	The contents of the specified Data Memory, Accumulator and the carry flag are added. The result is stored in the Accumulator.
Operation	$ACC \leftarrow ACC + [m] + C$
Affected flag(s)	OV, Z, AC, C
<b>ADCM A,[m]</b>	Add ACC to Data Memory with Carry
Description	The contents of the specified Data Memory, Accumulator and the carry flag are added. The result is stored in the specified Data Memory.
Operation	$[m] \leftarrow ACC + [m] + C$
Affected flag(s)	OV, Z, AC, C
<b>ADD A,[m]</b>	Add Data Memory to ACC
Description	The contents of the specified Data Memory and the Accumulator are added. The result is stored in the Accumulator.
Operation	$ACC \leftarrow ACC + [m]$
Affected flag(s)	OV, Z, AC, C
<b>ADD A,x</b>	Add immediate data to ACC
Description	The contents of the Accumulator and the specified immediate data are added. The result is stored in the Accumulator.
Operation	$ACC \leftarrow ACC + x$
Affected flag(s)	OV, Z, AC, C
<b>ADDM A,[m]</b>	Add ACC to Data Memory
Description	The contents of the specified Data Memory and the Accumulator are added. The result is stored in the specified Data Memory.
Operation	$[m] \leftarrow ACC + [m]$
Affected flag(s)	OV, Z, AC, C
<b>AND A,[m]</b>	Logical AND Data Memory to ACC
Description	Data in the Accumulator and the specified Data Memory perform a bitwise logical AND operation. The result is stored in the Accumulator.
Operation	$ACC \leftarrow ACC \text{ "AND" } [m]$
Affected flag(s)	Z
<b>AND A,x</b>	Logical AND immediate data to ACC
Description	Data in the Accumulator and the specified immediate data perform a bit wise logical AND operation. The result is stored in the Accumulator.
Operation	$ACC \leftarrow ACC \text{ "AND" } x$
Affected flag(s)	Z
<b>ANDM A,[m]</b>	Logical AND ACC to Data Memory
Description	Data in the specified Data Memory and the Accumulator perform a bitwise logical AND operation. The result is stored in the Data Memory.
Operation	$[m] \leftarrow ACC \text{ "AND" } [m]$
Affected flag(s)	Z



<b>CALL addr</b>	Subroutine call
Description	Unconditionally calls a subroutine at the specified address. The Program Counter then increments by 1 to obtain the address of the next instruction which is then pushed onto the stack. The specified address is then loaded and the program continues execution from this new address. As this instruction requires an additional operation, it is a two cycle instruction.
Operation	Stack ← Program Counter + 1 Program Counter ← addr
Affected flag(s)	None
<b>CLR [m]</b>	Clear Data Memory
Description	Each bit of the specified Data Memory is cleared to 0.
Operation	[m] ← 00H
Affected flag(s)	None
<b>CLR [m].i</b>	Clear bit of Data Memory
Description	Bit i of the specified Data Memory is cleared to 0.
Operation	[m].i ← 0
Affected flag(s)	None
<b>CLR WDT</b>	Clear Watchdog Timer
Description	The TO, PDF flags and the WDT are all cleared.
Operation	WDT cleared TO ← 0 PDF ← 0
Affected flag(s)	TO, PDF
<b>CPL [m]</b>	Complement Data Memory
Description	Each bit of the specified Data Memory is logically complemented (1's complement). Bits which previously contained a 1 are changed to 0 and vice versa.
Operation	[m] ← $\overline{[m]}$
Affected flag(s)	Z
<b>CPLA [m]</b>	Complement Data Memory with result in ACC
Description	Each bit of the specified Data Memory is logically complemented (1's complement). Bits which previously contained a 1 are changed to 0 and vice versa. The complemented result is stored in the Accumulator and the contents of the Data Memory remain unchanged.
Operation	ACC ← $\overline{[m]}$
Affected flag(s)	Z
<b>DAA [m]</b>	Decimal-Adjust ACC for addition with result in Data Memory
Description	Convert the contents of the Accumulator value to a BCD (Binary Coded Decimal) value resulting from the previous addition of two BCD variables. If the low nibble is greater than 9 or if AC flag is set, then a value of 6 will be added to the low nibble. Otherwise the low nibble remains unchanged. If the high nibble is greater than 9 or if the C flag is set, then a value of 6 will be added to the high nibble. Essentially, the decimal conversion is performed by adding 00H, 06H, 60H or 66H depending on the Accumulator and flag conditions. Only the C flag may be affected by this instruction which indicates that if the original BCD sum is greater than 100, it allows multiple precision decimal addition.
Operation	[m] ← ACC + 00H or [m] ← ACC + 06H or [m] ← ACC + 60H or [m] ← ACC + 66H
Affected flag(s)	C

<b>DEC [m]</b>	Decrement Data Memory
Description	Data in the specified Data Memory is decremented by 1.
Operation	$[m] \leftarrow [m] - 1$
Affected flag(s)	Z
<b>DECA [m]</b>	Decrement Data Memory with result in ACC
Description	Data in the specified Data Memory is decremented by 1. The result is stored in the Accumulator. The contents of the Data Memory remain unchanged.
Operation	$ACC \leftarrow [m] - 1$
Affected flag(s)	Z
<b>HALT</b>	Enter power down mode
Description	This instruction stops the program execution and turns off the system clock. The contents of the Data Memory and registers are retained. The WDT and prescaler are cleared. The power down flag PDF is set and the WDT time-out flag TO is cleared.
Operation	$TO \leftarrow 0$ $PDF \leftarrow 1$
Affected flag(s)	TO, PDF
<b>INC [m]</b>	Increment Data Memory
Description	Data in the specified Data Memory is incremented by 1.
Operation	$[m] \leftarrow [m] + 1$
Affected flag(s)	Z
<b>INCA [m]</b>	Increment Data Memory with result in ACC
Description	Data in the specified Data Memory is incremented by 1. The result is stored in the Accumulator. The contents of the Data Memory remain unchanged.
Operation	$ACC \leftarrow [m] + 1$
Affected flag(s)	Z
<b>JMP addr</b>	Jump unconditionally
Description	The contents of the Program Counter are replaced with the specified address. Program execution then continues from this new address. As this requires the insertion of a dummy instruction while the new address is loaded, it is a two cycle instruction.
Operation	Program Counter $\leftarrow$ addr
Affected flag(s)	None
<b>MOV A,[m]</b>	Move Data Memory to ACC
Description	The contents of the specified Data Memory are copied to the Accumulator.
Operation	$ACC \leftarrow [m]$
Affected flag(s)	None
<b>MOV A,x</b>	Move immediate data to ACC
Description	The immediate data specified is loaded into the Accumulator.
Operation	$ACC \leftarrow x$
Affected flag(s)	None
<b>MOV [m],A</b>	Move ACC to Data Memory
Description	The contents of the Accumulator are copied to the specified Data Memory.
Operation	$[m] \leftarrow ACC$
Affected flag(s)	None

<b>NOP</b>	No operation
Description	No operation is performed. Execution continues with the next instruction.
Operation	No operation
Affected flag(s)	None
<b>OR A,[m]</b>	Logical OR Data Memory to ACC
Description	Data in the Accumulator and the specified Data Memory perform a bitwise logical OR operation. The result is stored in the Accumulator.
Operation	ACC ← ACC "OR" [m]
Affected flag(s)	Z
<b>OR A,x</b>	Logical OR immediate data to ACC
Description	Data in the Accumulator and the specified immediate data perform a bitwise logical OR operation. The result is stored in the Accumulator.
Operation	ACC ← ACC "OR" x
Affected flag(s)	Z
<b>ORM A,[m]</b>	Logical OR ACC to Data Memory
Description	Data in the specified Data Memory and the Accumulator perform a bitwise logical OR operation. The result is stored in the Data Memory.
Operation	[m] ← ACC "OR" [m]
Affected flag(s)	Z
<b>RET</b>	Return from subroutine
Description	The Program Counter is restored from the stack. Program execution continues at the restored address.
Operation	Program Counter ← Stack
Affected flag(s)	None
<b>RET A,x</b>	Return from subroutine and load immediate data to ACC
Description	The Program Counter is restored from the stack and the Accumulator loaded with the specified immediate data. Program execution continues at the restored address.
Operation	Program Counter ← Stack ACC ← x
Affected flag(s)	None
<b>RETI</b>	Return from interrupt
Description	The Program Counter is restored from the stack and the interrupts are re-enabled by setting the EMI bit. EMI is the master interrupt global enable bit. If an interrupt was pending when the RETI instruction is executed, the pending Interrupt routine will be processed before returning to the main program.
Operation	Program Counter ← Stack EMI ← 1
Affected flag(s)	None
<b>RL [m]</b>	Rotate Data Memory left
Description	The contents of the specified Data Memory are rotated left by 1 bit with bit 7 rotated into bit 0.
Operation	[m].(i+1) ← [m].i; (i=0~6) [m].0 ← [m].7
Affected flag(s)	None

<b>RLA [m]</b>	Rotate Data Memory left with result in ACC
Description	The contents of the specified Data Memory are rotated left by 1 bit with bit 7 rotated into bit 0. The rotated result is stored in the Accumulator and the contents of the Data Memory remain unchanged.
Operation	$ACC.(i+1) \leftarrow [m].i; (i=0\sim6)$ $ACC.0 \leftarrow [m].7$
Affected flag(s)	None
<b>RLC [m]</b>	Rotate Data Memory left through Carry
Description	The contents of the specified Data Memory and the carry flag are rotated left by 1 bit. Bit 7 replaces the Carry bit and the original carry flag is rotated into bit 0.
Operation	$[m].(i+1) \leftarrow [m].i; (i=0\sim6)$ $[m].0 \leftarrow C$ $C \leftarrow [m].7$
Affected flag(s)	C
<b>RLCA [m]</b>	Rotate Data Memory left through Carry with result in ACC
Description	Data in the specified Data Memory and the carry flag are rotated left by 1 bit. Bit 7 replaces the Carry bit and the original carry flag is rotated into the bit 0. The rotated result is stored in the Accumulator and the contents of the Data Memory remain unchanged.
Operation	$ACC.(i+1) \leftarrow [m].i; (i=0\sim6)$ $ACC.0 \leftarrow C$ $C \leftarrow [m].7$
Affected flag(s)	C
<b>RR [m]</b>	Rotate Data Memory right
Description	The contents of the specified Data Memory are rotated right by 1 bit with bit 0 rotated into bit 7.
Operation	$[m].i \leftarrow [m].(i+1); (i=0\sim6)$ $[m].7 \leftarrow [m].0$
Affected flag(s)	None
<b>RRA [m]</b>	Rotate Data Memory right with result in ACC
Description	Data in the specified Data Memory is rotated right by 1 bit with bit 0 rotated into bit 7. The rotated result is stored in the Accumulator and the contents of the Data Memory remain unchanged.
Operation	$ACC.i \leftarrow [m].(i+1); (i=0\sim6)$ $ACC.7 \leftarrow [m].0$
Affected flag(s)	None
<b>RRC [m]</b>	Rotate Data Memory right through Carry
Description	The contents of the specified Data Memory and the carry flag are rotated right by 1 bit. Bit 0 replaces the Carry bit and the original carry flag is rotated into bit 7.
Operation	$[m].i \leftarrow [m].(i+1); (i=0\sim6)$ $[m].7 \leftarrow C$ $C \leftarrow [m].0$
Affected flag(s)	C

<b>RRCA [m]</b>	Rotate Data Memory right through Carry with result in ACC
Description	Data in the specified Data Memory and the carry flag are rotated right by 1 bit. Bit 0 replaces the Carry bit and the original carry flag is rotated into bit 7. The rotated result is stored in the Accumulator and the contents of the Data Memory remain unchanged.
Operation	$ACC.i \leftarrow [m].(i+1); (i=0\sim 6)$ $ACC.7 \leftarrow C$ $C \leftarrow [m].0$
Affected flag(s)	C
<b>SBC A,[m]</b>	Subtract Data Memory from ACC with Carry
Description	The contents of the specified Data Memory and the complement of the carry flag are subtracted from the Accumulator. The result is stored in the Accumulator. Note that if the result of subtraction is negative, the C flag will be cleared to 0, otherwise if the result is positive or zero, the C flag will be set to 1.
Operation	$ACC \leftarrow ACC - [m] - \bar{C}$
Affected flag(s)	OV, Z, AC, C
<b>SBCM A,[m]</b>	Subtract Data Memory from ACC with Carry and result in Data Memory
Description	The contents of the specified Data Memory and the complement of the carry flag are subtracted from the Accumulator. The result is stored in the Data Memory. Note that if the result of subtraction is negative, the C flag will be cleared to 0, otherwise if the result is positive or zero, the C flag will be set to 1.
Operation	$[m] \leftarrow ACC - [m] - \bar{C}$
Affected flag(s)	OV, Z, AC, C
<b>SDZ [m]</b>	Skip if decrement Data Memory is 0
Description	The contents of the specified Data Memory are first decremented by 1. If the result is 0 the following instruction is skipped. As this requires the insertion of a dummy instruction while the next instruction is fetched, it is a two cycle instruction. If the result is not 0 the program proceeds with the following instruction.
Operation	$[m] \leftarrow [m] - 1$ Skip if $[m]=0$
Affected flag(s)	None
<b>SDZA [m]</b>	Skip if decrement Data Memory is zero with result in ACC
Description	The contents of the specified Data Memory are first decremented by 1. If the result is 0, the following instruction is skipped. The result is stored in the Accumulator but the specified Data Memory contents remain unchanged. As this requires the insertion of a dummy instruction while the next instruction is fetched, it is a two cycle instruction. If the result is not 0, the program proceeds with the following instruction.
Operation	$ACC \leftarrow [m] - 1$ Skip if $ACC=0$
Affected flag(s)	None
<b>SET [m]</b>	Set Data Memory
Description	Each bit of the specified Data Memory is set to 1.
Operation	$[m] \leftarrow FFH$
Affected flag(s)	None
<b>SET [m].i</b>	Set bit of Data Memory
Description	Bit i of the specified Data Memory is set to 1.
Operation	$[m].i \leftarrow 1$
Affected flag(s)	None

<b>SIZ [m]</b>	Skip if increment Data Memory is 0
Description	The contents of the specified Data Memory are first incremented by 1. If the result is 0, the following instruction is skipped. As this requires the insertion of a dummy instruction while the next instruction is fetched, it is a two cycle instruction. If the result is not 0 the program proceeds with the following instruction.
Operation	$[m] \leftarrow [m] + 1$ Skip if $[m]=0$
Affected flag(s)	None
<b>SIZA [m]</b>	Skip if increment Data Memory is zero with result in ACC
Description	The contents of the specified Data Memory are first incremented by 1. If the result is 0, the following instruction is skipped. The result is stored in the Accumulator but the specified Data Memory contents remain unchanged. As this requires the insertion of a dummy instruction while the next instruction is fetched, it is a two cycle instruction. If the result is not 0 the program proceeds with the following instruction.
Operation	$ACC \leftarrow [m] + 1$ Skip if $ACC=0$
Affected flag(s)	None
<b>SNZ [m].i</b>	Skip if bit i of Data Memory is not 0
Description	If bit i of the specified Data Memory is not 0, the following instruction is skipped. As this requires the insertion of a dummy instruction while the next instruction is fetched, it is a two cycle instruction. If the result is 0 the program proceeds with the following instruction.
Operation	Skip if $[m].i \neq 0$
Affected flag(s)	None
<b>SUB A,[m]</b>	Subtract Data Memory from ACC
Description	The specified Data Memory is subtracted from the contents of the Accumulator. The result is stored in the Accumulator. Note that if the result of subtraction is negative, the C flag will be cleared to 0, otherwise if the result is positive or zero, the C flag will be set to 1.
Operation	$ACC \leftarrow ACC - [m]$
Affected flag(s)	OV, Z, AC, C
<b>SUBM A,[m]</b>	Subtract Data Memory from ACC with result in Data Memory
Description	The specified Data Memory is subtracted from the contents of the Accumulator. The result is stored in the Data Memory. Note that if the result of subtraction is negative, the C flag will be cleared to 0, otherwise if the result is positive or zero, the C flag will be set to 1.
Operation	$[m] \leftarrow ACC - [m]$
Affected flag(s)	OV, Z, AC, C
<b>SUB A,x</b>	Subtract immediate data from ACC
Description	The immediate data specified by the code is subtracted from the contents of the Accumulator. The result is stored in the Accumulator. Note that if the result of subtraction is negative, the C flag will be cleared to 0, otherwise if the result is positive or zero, the C flag will be set to 1.
Operation	$ACC \leftarrow ACC - x$
Affected flag(s)	OV, Z, AC, C
<b>SWAP [m]</b>	Swap nibbles of Data Memory
Description	The low-order and high-order nibbles of the specified Data Memory are interchanged.
Operation	$[m].3\sim[m].0 \leftrightarrow [m].7\sim[m].4$
Affected flag(s)	None

<b>SWAPA [m]</b>	Swap nibbles of Data Memory with result in ACC
Description	The low-order and high-order nibbles of the specified Data Memory are interchanged. The result is stored in the Accumulator. The contents of the Data Memory remain unchanged.
Operation	ACC.3~ACC.0 ← [m].7~[m].4 ACC.7~ACC.4 ← [m].3~[m].0
Affected flag(s)	None
<b>SZ [m]</b>	Skip if Data Memory is 0
Description	The contents of the specified Data Memory are read out and then written to the specified Data Memory again. If the contents of the specified Data Memory is 0, the following instruction is skipped. As this requires the insertion of a dummy instruction while the next instruction is fetched, it is a two cycle instruction. If the result is not 0 the program proceeds with the following instruction.
Operation	Skip if [m]=0
Affected flag(s)	None
<b>SZA [m]</b>	Skip if Data Memory is 0 with data movement to ACC
Description	The contents of the specified Data Memory are copied to the Accumulator. If the value is zero, the following instruction is skipped. As this requires the insertion of a dummy instruction while the next instruction is fetched, it is a two cycle instruction. If the result is not 0 the program proceeds with the following instruction.
Operation	ACC ← [m] Skip if [m]=0
Affected flag(s)	None
<b>SZ [m].i</b>	Skip if bit i of Data Memory is 0
Description	If bit i of the specified Data Memory is 0, the following instruction is skipped. As this requires the insertion of a dummy instruction while the next instruction is fetched, it is a two cycle instruction. If the result is not 0, the program proceeds with the following instruction.
Operation	Skip if [m].i=0
Affected flag(s)	None
<b>TABRD [m]</b>	Read table (specific page or current page) to TBLH and Data Memory
Description	The low byte of the program code addressed by the table pointer (TBHP and TBLP or only TBLP if no TBHP) is moved to the specified Data Memory and the high byte moved to TBLH.
Operation	[m] ← program code (low byte) TBLH ← program code (high byte)
Affected flag(s)	None
<b>TABRDL [m]</b>	Read table (last page) to TBLH and Data Memory
Description	The low byte of the program code (last page) addressed by the table pointer (TBLP) is moved to the specified Data Memory and the high byte moved to TBLH.
Operation	[m] ← program code (low byte) TBLH ← program code (high byte)
Affected flag(s)	None
<b>XOR A,[m]</b>	Logical XOR Data Memory to ACC
Description	Data in the Accumulator and the specified Data Memory perform a bitwise logical XOR operation. The result is stored in the Accumulator.
Operation	ACC ← ACC "XOR" [m]
Affected flag(s)	Z



**XORM A,[m]** Logical XOR ACC to Data Memory  
Description Data in the specified Data Memory and the Accumulator perform a bitwise logical XOR operation. The result is stored in the Data Memory.  
Operation  $[m] \leftarrow \text{ACC} \text{ "XOR" } [m]$   
Affected flag(s) Z

**XOR A,x** Logical XOR immediate data to ACC  
Description Data in the Accumulator and the specified immediate data perform a bitwise logical XOR operation. The result is stored in the Accumulator.  
Operation  $\text{ACC} \leftarrow \text{ACC} \text{ "XOR" } x$   
Affected flag(s) Z

## Package Information

Note that the package information provided here is for consultation purposes only. As this information may be updated at regular intervals users are reminded to consult the [Holtek website](#) for the latest version of the [Package/Carton Information](#).

Additional supplementary information with regard to packaging is listed below. Click on the relevant section to be transferred to the relevant website page.

- [Package Information \(include Outline Dimensions, Product Tape and Reel Specifications\)](#)
- [The Operation Instruction of Packing Materials](#)
- [Carton information](#)

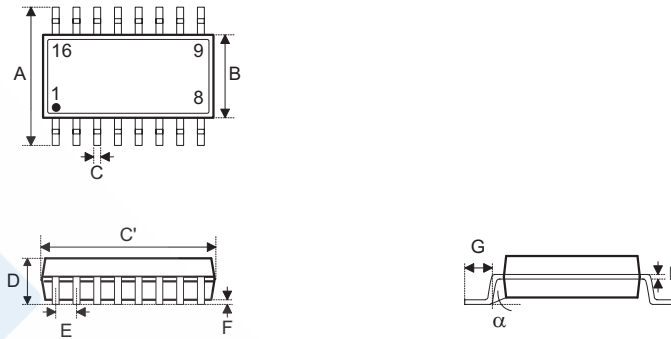
**16-pin NSOP (150mil) Outline Dimensions**

Symbol	Dimensions in inch		
	Min.	Nom.	Max.
A	—	0.236 BSC	—
B	—	0.154 BSC	—
C	0.012	—	0.020
C'	—	0.390 BSC	—
D	—	—	0.069
E	—	0.050 BSC	—
F	0.004	—	0.010
G	0.016	—	0.050
H	0.004	—	0.010
$\alpha$	0°	—	8°

Symbol	Dimensions in mm		
	Min.	Nom.	Max.
A	—	6.00 BSC	—
B	—	3.90 BSC	—
C	0.31	—	0.51
C'	—	9.90 BSC	—
D	—	—	1.75
E	—	1.27 BSC	—
F	0.10	—	0.25
G	0.40	—	1.27
H	0.10	—	0.25
$\alpha$	0°	—	8°

20-pin NSOP (150mil) Outline Dimensions

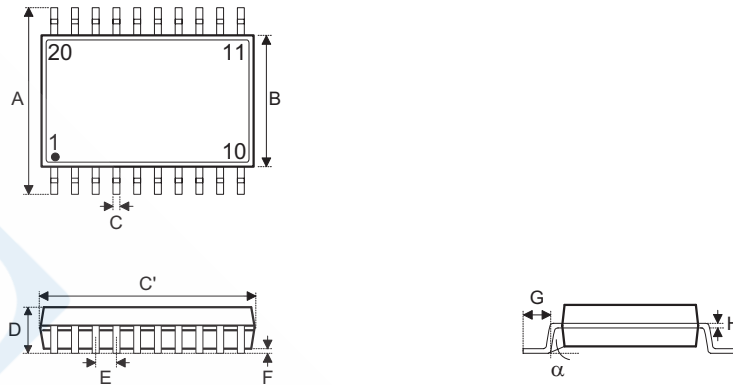

Symbol	Dimensions in inch		
	Min.	Nom.	Max.
A	0.228	0.236	0.244
B	0.146	0.154	0.161
C	0.009	—	0.012
C'	0.382	0.390	0.398
D	—	—	0.069
E	—	0.032 BSC	—
F	0.002	—	0.009
G	0.020	—	0.031
H	0.008	—	0.010
$\alpha$	0°	—	8°

Symbol	Dimensions in mm		
	Min.	Nom.	Max.
A	5.80	6.00	6.20
B	3.70	3.90	4.10
C	0.23	—	0.30
C'	9.70	9.90	10.10
D	—	—	1.75
E	—	0.80 BSC	—
F	0.05	—	0.23
G	0.50	—	0.80
H	0.21	—	0.25
$\alpha$	0°	—	8°



Singel 3 | B-2550 Kontich | Belgium | Tel. +32 (0)3 458 30 33  
info@alcom.be | www.alcom.be

Rivium 1e straat 52 | 2909 LE Capelle aan den IJssel | The Netherlands  
Tel. +31 (0)10 288 25 00 | info@alcom.nl | www.alcom.nl

Copyright© 2021 by HOLTEK SEMICONDUCTOR INC.

The information appearing in this Data Sheet is believed to be accurate at the time of publication. However, Holtek assumes no responsibility arising from the use of the specifications described. The applications mentioned herein are used solely for the purpose of illustration and Holtek makes no warranty or representation that such applications will be suitable without further modification, nor recommends the use of its products for application that may present a risk to human life due to malfunction or otherwise. Holtek's products are not authorized for use as critical components in life support devices or systems. Holtek reserves the right to alter its products without prior notification. For the most up-to-date information, please visit our web site at <http://www.holtek.com>.