

**GigaDevice Semiconductor Inc.**

**GD32E235xx**

**ARM<sup>®</sup> Cortex<sup>®</sup>-M23 32-bit MCU**

**Datasheet**

Revision 1.0

(Feb. 2024)



Singel 3 | B-2550 Kontich | Belgium | Tel. +32 (0)3 458 30 33  
info@alcom.be | www.alcom.be  
Rivium 1e straat 52 | 2909 LE Capelle aan den IJssel | The Netherlands  
Tel. +31 (0)10 288 25 00 | info@alcom.nl | www.alcom.nl

## Table of Contents

<b>Table of Contents</b> .....	<b>1</b>
<b>List of Figures</b> .....	<b>4</b>
<b>List of Tables</b> .....	<b>5</b>
<b>1 General description</b> .....	<b>7</b>
<b>2 Device overview</b> .....	<b>8</b>
<b>2.1 Device information</b> .....	<b>8</b>
<b>2.2 Block diagram</b> .....	<b>10</b>
<b>2.3 Pinouts and pin assignment</b> .....	<b>11</b>
<b>2.4 Memory map</b> .....	<b>14</b>
<b>2.5 Clock tree</b> .....	<b>16</b>
<b>2.6 Pin definitions</b> .....	<b>17</b>
2.6.1 GD32E235Cx LQFP48 pin definitions .....	17
2.6.2 GD32E235Kx LQFP32 pin definitions .....	20
2.6.3 GD32E235Kx QFN32 pin definitions .....	22
2.6.4 GD32E235Gx QFN28 pin definitions.....	25
2.6.5 GD32E235Fx TSSOP20 pin definitions.....	27
2.6.6 GD32E235Fx LGA20 pin definitions.....	28
2.6.7 GD32E235xx pin alternate functions.....	31
<b>3 Functional description</b> .....	<b>34</b>
<b>3.1 ARM® Cortex®-M23 core</b> .....	<b>34</b>
<b>3.2 Embedded memory</b> .....	<b>34</b>
<b>3.3 Clock, reset and supply management</b> .....	<b>34</b>
<b>3.4 Boot modes</b> .....	<b>35</b>
<b>3.5 Power saving modes</b> .....	<b>35</b>
<b>3.6 Analog to digital converter (ADC)</b> .....	<b>36</b>
<b>3.7 DMA</b> .....	<b>37</b>
<b>3.8 General-purpose inputs/outputs (GPIOs)</b> .....	<b>37</b>
<b>3.9 Timers and PWM generation</b> .....	<b>37</b>
<b>3.10 Real time clock (RTC)</b> .....	<b>38</b>
<b>3.11 Inter-integrated circuit (I2C)</b> .....	<b>39</b>
<b>3.12 Serial peripheral interface (SPI)</b> .....	<b>39</b>

3.13	Universal synchronous asynchronous receiver transmitter (USART) .....	40
3.14	Inter-IC sound (I2S) .....	40
3.15	Comparators (CMP).....	40
3.16	Debug mode .....	40
3.17	Package and operation temperature.....	41
<b>4</b>	<b>Electrical characteristics.....</b>	<b>42</b>
4.1	Absolute maximum ratings.....	42
4.2	Operating conditions characteristics.....	42
4.3	Power consumption .....	44
4.4	EMC characteristics .....	49
4.5	Power supply supervisor characteristics .....	50
4.6	External clock characteristics .....	51
4.7	Internal clock characteristics .....	53
4.8	PLL characteristics.....	54
4.9	Memory characteristics.....	55
4.10	NRST pin characteristics .....	55
4.11	GPIO characteristics .....	56
4.12	ADC characteristics .....	57
4.13	Temperature sensor characteristics.....	59
4.14	Comparators characteristics.....	59
4.15	TIMER characteristics.....	60
4.16	I2C characteristics .....	61
4.17	SPI characteristics .....	62
4.18	I2S characteristics.....	64
4.19	USART characteristics.....	66
4.20	WDGT characteristics .....	66
4.21	Parameter conditions.....	66
<b>5</b>	<b>Package information.....</b>	<b>67</b>
5.1	LQFP48 package outline dimensions.....	67
5.2	LQFP32 package outline dimensions.....	69
5.3	QFN32 package outline dimensions .....	71
5.4	QFN28 package outline dimensions .....	73



---

5.5	TSSOP20 package outline dimensions .....	75
5.6	LGA20 package outline dimensions .....	77
5.7	Thermal characteristics .....	79
6	Ordering information .....	81
7	Revision history .....	82



## List of Figures

Figure 2-1. GD32E235xx block diagram .....	10
Figure 2-2. GD32E235Cx LQFP48 pinouts .....	11
Figure 2-3. GD32E235Kx LQFP32 pinouts .....	11
Figure 2-4. GD32E235Kx QFN32 pinouts .....	12
Figure 2-5. GD32E235Gx QFN28 pinouts .....	12
Figure 2-6. GD32E235Fx TSSOP20 pinouts .....	12
Figure 2-7. GD32E235Fx LGA20 pinouts.....	13
Figure 2-8. GD32E235xx clock tree.....	16
Figure 4-1. Recommended power supply decoupling capacitors <sup>(1)(2)</sup> .....	43
Figure 4-2. Typical supply current consumption in Run mode .....	48
Figure 4-3. Typical supply current consumption in Sleep mode.....	48
Figure 4-4. Recommended external NRST pin circuit.....	55
Figure 4-5. I/O port AC characteristics definition.....	57
Figure 4-6. CMP hysteresis.....	60
Figure 4-7. I2C bus timing diagram.....	61
Figure 4-8. SPI timing diagram - master mode .....	62
Figure 4-9. SPI timing diagram - slave mode.....	63
Figure 4-10. I2S timing diagram - master mode .....	65
Figure 4-11. I2S timing diagram - slave mode .....	65
Figure 5-1. LQFP48 package outline .....	67
Figure 5-2. LQFP48 recommended footprint .....	68
Figure 5-3. LQFP32 package outline .....	69
Figure 5-4. LQFP32 recommended footprint .....	70
Figure 5-5. QFN32 package outline .....	71
Figure 5-6. QFN32 recommended footprint .....	72
Figure 5-7. QFN28 package outline .....	73
Figure 5-8. QFN28 recommended footprint .....	74
Figure 5-9. TSSOP20 package outline.....	75
Figure 5-10. TSSOP20 recommended footprint.....	76
Figure 5-11. LGA20 package outline .....	77
Figure 5-12. LGA20 recommended footprint .....	78

## List of Tables

Table 2-1. GD32E235xx devices features and peripheral list.....	8
Table 2-2. GD32E235xx devices features and peripheral list (continued).....	9
Table 2-3. GD32E235xx memory map.....	14
Table 2-4. GD32E235Cx LQFP48 pin definitions .....	17
Table 2-5. GD32E235Kx LQFP32 pin definitions .....	20
Table 2-6. GD32E235Kx QFN32 pin definitions .....	22
Table 2-7. GD32E235Gx QFN28 pin definitions .....	25
Table 2-8. GD32E235Fx TSSOP20 pin definitions .....	27
Table 2-9. GD32E235Fx LGA20 pin definitions.....	28
Table 2-10. Port A alternate functions summary .....	31
Table 2-11. Port B alternate functions summary .....	32
Table 2-12. Port F alternate functions summary .....	32
Table 4-1. Absolute maximum ratings <sup>(1)(4)</sup> .....	42
Table 4-2. DC operating conditions .....	42
Table 4-3. Clock frequency <sup>(1)</sup> .....	43
Table 4-4. Operating conditions at Power up/ Power down <sup>(1)</sup> .....	43
Table 4-5. Start-up timings of Operating conditions <sup>(1)(2)(3)</sup> .....	43
Table 4-6. Power saving mode wakeup timings characteristics <sup>(1)(2)</sup> .....	43
Table 4-7. Power consumption characteristics <sup>(2)(3)(4)(5)</sup> .....	44
Table 4-8. System level ESD and EFT characteristics <sup>(1)</sup> .....	49
Table 4-9. EMI characteristics <sup>(1)</sup> .....	49
Table 4-10. Component level ESD and latch-up characteristics <sup>(1)</sup> .....	50
Table 4-11. Power supply supervisor characteristics <sup>(1)</sup> .....	50
Table 4-12. High speed external clock (HXTAL) generated from a crystal/ceramic characteristics .	51
Table 4-13. High speed external user clock characteristics (HXTAL in bypass mode).....	51
Table 4-14. Low speed external clock (LXTAL) generated from a crystal/ceramic characteristics ..	52
Table 4-15. Low speed external user clock characteristics (LXTAL in bypass mode).....	52
Table 4-16. High speed internal clock (IRC8M) characteristics .....	53
Table 4-17. Low speed internal clock (IRC40K) characteristics .....	53
Table 4-18. High speed internal clock (IRC28M) characteristics .....	54
Table 4-19. PLL characteristics .....	54
Table 4-20. Flash memory characteristics .....	55
Table 4-21. NRST pin characteristics.....	55
Table 4-22. I/O port DC characteristics <sup>(1)(3)</sup> .....	56
Table 4-23. I/O port AC characteristics <sup>(1)(2)</sup> .....	56
Table 4-24. ADC characteristics .....	57
Table 4-25. Internal reference voltage calibration values .....	58
Table 4-26. ADC R <sub>AIN</sub> max for f <sub>ADC</sub> = 28 MHz <sup>(1)(2)</sup> .....	58
Table 4-27. ADC dynamic accuracy at f <sub>ADC</sub> = 28 MHz <sup>(1)</sup> .....	58
Table 4-28. ADC static accuracy at f <sub>ADC</sub> = 28 MHz <sup>(1)</sup> .....	58

<b>Table 4-29. Temperature sensor characteristics</b> .....	<b>59</b>
<b>Table 4-30. Temperature sensor calibration values</b> .....	<b>59</b>
<b>Table 4-31. CMP characteristics<sup>(1)</sup></b> .....	<b>59</b>
<b>Table 4-32. TIMER characteristics<sup>(1)</sup></b> .....	<b>60</b>
<b>Table 4-33. I2C characteristics<sup>(1)(2)</sup></b> .....	<b>61</b>
<b>Table 4-34. Standard SPI characteristics<sup>(1)</sup></b> .....	<b>62</b>
<b>Table 4-35. I2S characteristics<sup>(1)</sup></b> .....	<b>64</b>
<b>Table 4-36. USART characteristics<sup>(1)</sup></b> .....	<b>66</b>
<b>Table 4-37. FWDGT min/max timeout period at 40 kHz (IRC40K)<sup>(1)</sup></b> .....	<b>66</b>
<b>Table 4-38. WWDGT min-max timeout value at 72 MHz (f<sub>PCLK1</sub>)<sup>(1)</sup></b> .....	<b>66</b>
<b>Table 5-1. LQFP48 package dimensions</b> .....	<b>67</b>
<b>Table 5-2. LQFP32 package dimensions</b> .....	<b>69</b>
<b>Table 5-3. QFN32 package dimensions</b> .....	<b>71</b>
<b>Table 5-4. QFN28 package dimensions</b> .....	<b>73</b>
<b>Table 5-5. TSSOP20 package dimensions</b> .....	<b>75</b>
<b>Table 5-6. LGA20 package dimensions</b> .....	<b>77</b>
<b>Table 5-7. Package thermal characteristics<sup>(1)</sup></b> .....	<b>79</b>
<b>Table 6-1. Part ordering code for GD32E235xx devices</b> .....	<b>81</b>
<b>Table 7-1. Revision history</b> .....	<b>82</b>

## 1 General description

The GD32E235xx device belongs to the value line of GD32 MCU family. It is a new 32-bit general-purpose microcontroller based on the ARM® Cortex®-M23 core. The Cortex-M23 processor is an energy-efficient processor with a very low gate count. It is intended to be used for microcontroller and deeply embedded applications that require an area-optimized processor. The processor delivers high energy efficiency through a small but powerful instruction set and extensively optimized design, providing high-end processing hardware including a single-cycle multiplier and a 17-cycle divider.

The GD32E235xx device incorporates the ARM® Cortex®-M23 32-bit processor core operating at up to 72 MHz frequency with Flash accesses 0~2 wait states to obtain maximum efficiency. It provides up to 128 KB embedded Flash memory and up to 16 KB SRAM memory. An extensive range of enhanced I/Os and peripherals connected to two APB buses. The devices offer one 12-bit ADC and one comparator, up to five general 16-bit timers, a basic timer, a PWM advanced timer, as well as standard and advanced communication interfaces: up to two SPIs, two I2Cs, two USARTs, and an I2S.

The device operates from a 1.8 to 3.6 V power supply and available in -40 to +85 °C temperature range for grade 6 devices. Several power saving modes provide the flexibility for maximum optimization between wakeup latency and power consumption, an especially important consideration in low power applications.

The above features make the GD32E235xx devices suitable for a wide range of applications, especially in areas such as industrial control, motor drives, user interface, power monitor and alarm systems, consumer and handheld equipment, gaming and GPS, E-bike and so on.





## 2 Device overview

### 2.1 Device information

**Table 2-1. GD32E235xx devices features and peripheral list**

Part Number	GD32E235												
	K4U6	K6U6	K8U6	KBU6	K4T6	K6T6	K8T6	KBT6	C4T6	C6T6	C8T6	CBT6	
<b>FLASH (KB)</b>	16	32	64	128	16	32	64	128	16	32	64	128	
<b>SRAM (KB)</b>	4	6	8	16	4	6	8	16	4	6	8	16	
<b>Timers</b>	<b>General timer(16-bit)</b>	4 <small>(2,13,15,16)</small>	4 <small>(2,13,15,16)</small>	5 <small>(2,13-16)</small>	5 <small>(2,13-16)</small>	4 <small>(2,13,15,16)</small>	4 <small>(2,13,15,16)</small>	5 <small>(2,13-16)</small>	5 <small>(2,13-16)</small>	4 <small>(2,13,15,16)</small>	4 <small>(2,13,15,16)</small>	5 <small>(2,13-16)</small>	5 <small>(2,13-16)</small>
	<b>Advanced timer(16-bit)</b>	1 <small>(0)</small>	1 <small>(0)</small>	1 <small>(0)</small>	1 <small>(0)</small>	1 <small>(0)</small>	1 <small>(0)</small>	1 <small>(0)</small>	1 <small>(0)</small>	1 <small>(0)</small>	1 <small>(0)</small>	1 <small>(0)</small>	1 <small>(0)</small>
	<b>SysTick</b>	1	1	1	1	1	1	1	1	1	1	1	1
	<b>Basic timer(16-bit)</b>	1 <small>(5)</small>	1 <small>(5)</small>	1 <small>(5)</small>	1 <small>(5)</small>	1 <small>(5)</small>	1 <small>(5)</small>	1 <small>(5)</small>	1 <small>(5)</small>	1 <small>(5)</small>	1 <small>(5)</small>	1 <small>(5)</small>	1 <small>(5)</small>
	<b>Watchdog</b>	2	2	2	2	2	2	2	2	2	2	2	2
	<b>RTC</b>	1	1	1	1	1	1	1	1	1	1	1	1
<b>Connectivity</b>	<b>USART</b>	1 <small>(0)</small>	2 <small>(0-1)</small>	2 <small>(0-1)</small>	2 <small>(0-1)</small>	1 <small>(0)</small>	2 <small>(0-1)</small>	2 <small>(0-1)</small>	2 <small>(0-1)</small>	1 <small>(0)</small>	2 <small>(0-1)</small>	2 <small>(0-1)</small>	2 <small>(0-1)</small>
	<b>I2C</b>	1 <small>(0)</small>	1 <small>(0)</small>	2 <small>(0-1)</small>	2 <small>(0-1)</small>	1 <small>(0)</small>	1 <small>(0)</small>	2 <small>(0-1)</small>	2 <small>(0-1)</small>	1 <small>(0)</small>	1 <small>(0)</small>	2 <small>(0-1)</small>	2 <small>(0-1)</small>
	<b>SPI/I2S</b>	1/1 <small>(0)/(0)</small>	1/1 <small>(0)/(0)</small>	2/1 <small>(0-1)/(0)</small>	2/1 <small>(0-1)/(0)</small>	1/1 <small>(0)/(0)</small>	1/1 <small>(0)/(0)</small>	2/1 <small>(0-1)/(0)</small>	2/1 <small>(0-1)/(0)</small>	1/1 <small>(0)/(0)</small>	1/1 <small>(0)/(0)</small>	2/1 <small>(0-1)/(0)</small>	2/1 <small>(0-1)/(0)</small>
<b>GPIO</b>	27	27	27	27	25	25	25	25	39	39	39	39	
<b>CMP</b>	1	1	1	1	1	1	1	1	1	1	1	1	
<b>EXTI</b>	16	16	16	16	16	16	16	16	16	16	16	16	
<b>ADC</b>	<b>Units</b>	1	1	1	1	1	1	1	1	1	1	1	
	<b>Channels (External)</b>	10	10	10	10	10	10	10	10	10	10	10	
	<b>Channels (Internal)</b>	2	2	2	2	2	2	2	2	2	2	2	
<b>Package</b>	QFN32				LQFP32				LQFP48				

**Table 2-2. GD32E235xx devices features and peripheral list (continued)**

Part Number		GD32E235								
		F4V6	F6V6	F8V6	F4P6	F6P6	F8P6	G4U6	G6U6	G8U6
<b>FLASH (KB)</b>		16	32	64	16	32	64	16	32	64
<b>SRAM (KB)</b>		4	6	8	4	6	8	4	6	8
<b>Timers</b>	<b>General timer(16-bit)</b>	4 <small>(2,13,15,16)</small>	4 <small>(2,13,15,16)</small>	4 <small>(2,13,15,16)</small>	4 <small>(2,13,15,16)</small>	4 <small>(2,13,15,16)</small>	4 <small>(2,13,15,16)</small>	4 <small>(2,13,15,16)</small>	4 <small>(2,13,15,16)</small>	5 <small>(2,13-16)</small>
	<b>Advanced timer(16-bit)</b>	1 <small>(0)</small>	1 <small>(0)</small>	1 <small>(0)</small>	1 <small>(0)</small>	1 <small>(0)</small>	1 <small>(0)</small>	1 <small>(0)</small>	1 <small>(0)</small>	1 <small>(0)</small>
	<b>SysTick</b>	1	1	1	1	1	1	1	1	1
	<b>Basic timer(16-bit)</b>	1 <small>(5)</small>	1 <small>(5)</small>	1 <small>(5)</small>	1 <small>(5)</small>	1 <small>(5)</small>	1 <small>(5)</small>	1 <small>(5)</small>	1 <small>(5)</small>	1 <small>(5)</small>
	<b>Watchdog</b>	2	2	2	2	2	2	2	2	2
	<b>RTC</b>	1	1	1	1	1	1	1	1	1
<b>Connectivity</b>	<b>USART</b>	1 <small>(0)</small>	2 <small>(0-1)</small>	2 <small>(0-1)</small>	1 <small>(0)</small>	2 <small>(0-1)</small>	2 <small>(0-1)</small>	1 <small>(0)</small>	2 <small>(0-1)</small>	2 <small>(0-1)</small>
	<b>I2C</b>	1 <small>(0)</small>	1 <small>(0)</small>	2 <small>(0-1)</small>	1 <small>(0)</small>	1 <small>(0)</small>	2 <small>(0-1)</small>	1 <small>(0)</small>	1 <small>(0)</small>	2 <small>(0-1)</small>
	<b>SPI/I2S</b>	1/1 <small>(0)/(0)</small>	1/1 <small>(0)/(0)</small>	2/1 <small>(0-1)/(0)</small>	1/1 <small>(0)/(0)</small>	1/1 <small>(0)/(0)</small>	2/1 <small>(0-1)/(0)</small>	1/1 <small>(0)/(0)</small>	1/1 <small>(0)/(0)</small>	2/1 <small>(0-1)/(0)</small>
<b>GPIO</b>		15	15	15	15	15	15	23	23	23
<b>CMP</b>		1	1	1	1	1	1	1	1	1
<b>EXTI</b>		16	16	16	16	16	16	16	16	16
<b>ADC</b>	<b>Units</b>	1	1	1	1	1	1	1	1	1
	<b>Channels (External)</b>	9	9	9	9	9	9	10	10	10
	<b>Channels (Internal)</b>	2	2	2	2	2	2	2	2	2
<b>Package</b>		LGA20			TSSOP20			QFN28		

## 2.2 Block diagram

Figure 2-1. GD32E235xx block diagram

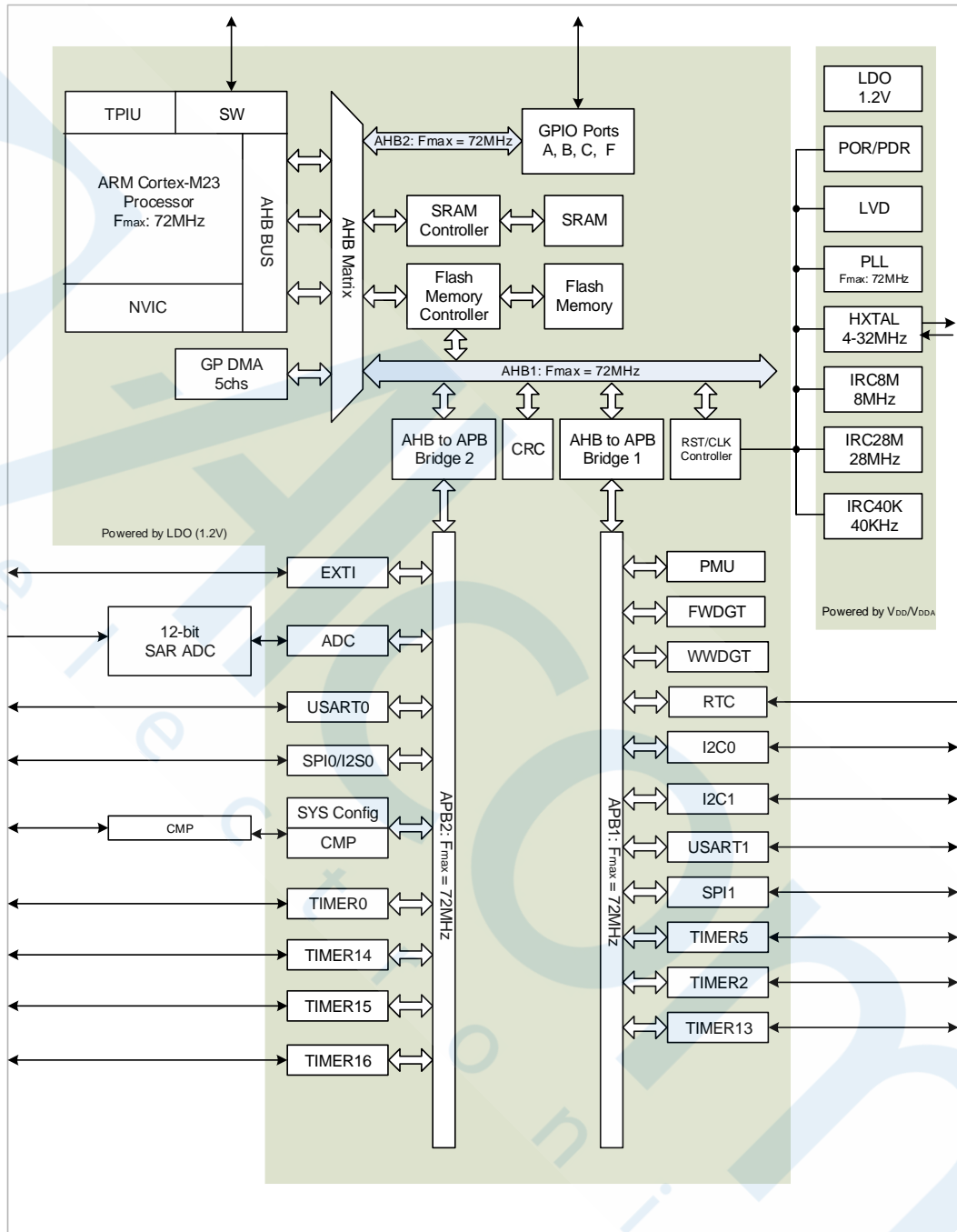

## 2.3 Pinouts and pin assignment

Figure 2-2. GD32E235Cx LQFP48 pinouts

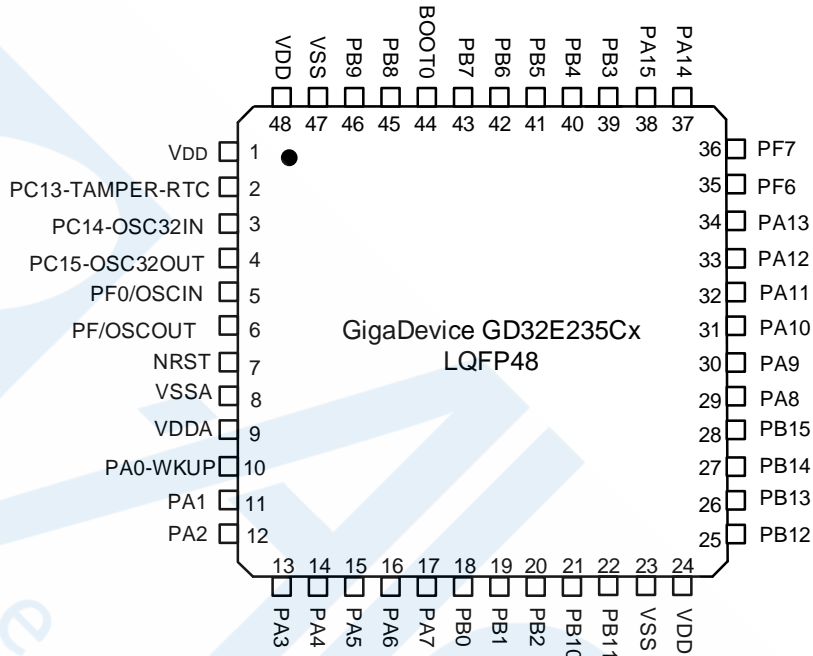

Figure 2-3. GD32E235Kx LQFP32 pinouts

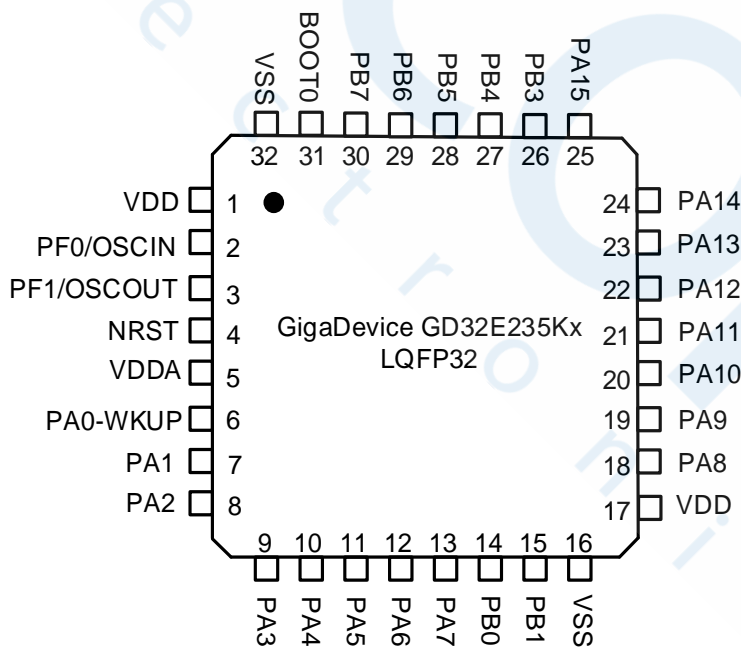

Figure 2-4. GD32E235Kx QFN32 pinouts

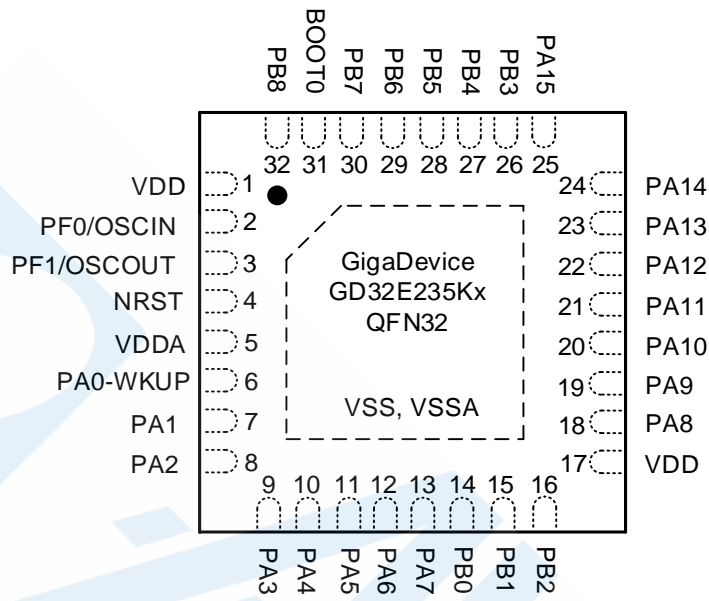

Figure 2-5. GD32E235Gx QFN28 pinouts

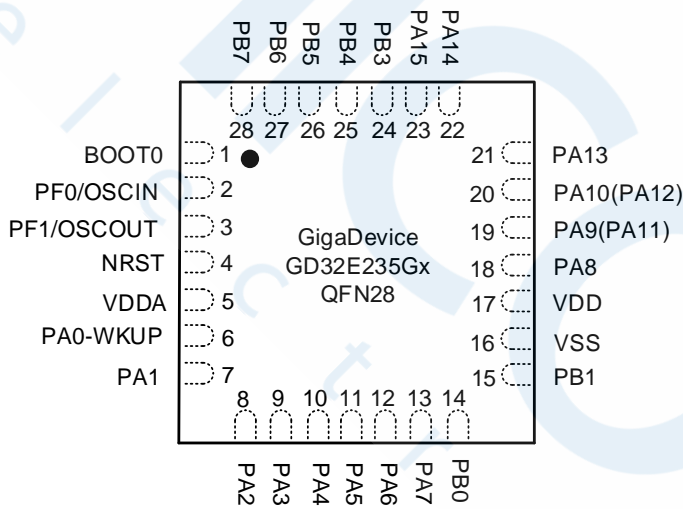

Figure 2-6. GD32E235Fx TSSOP20 pinouts

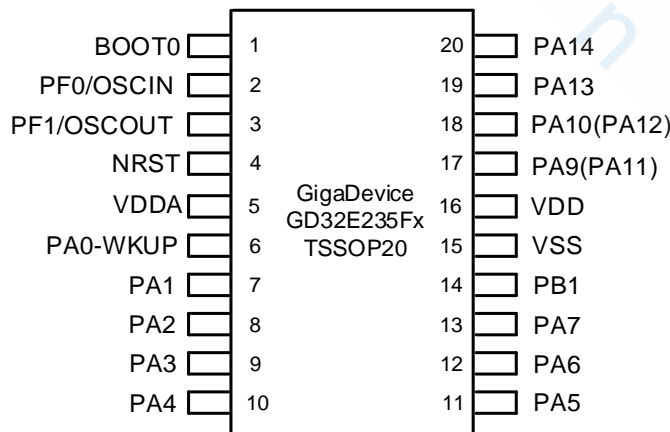
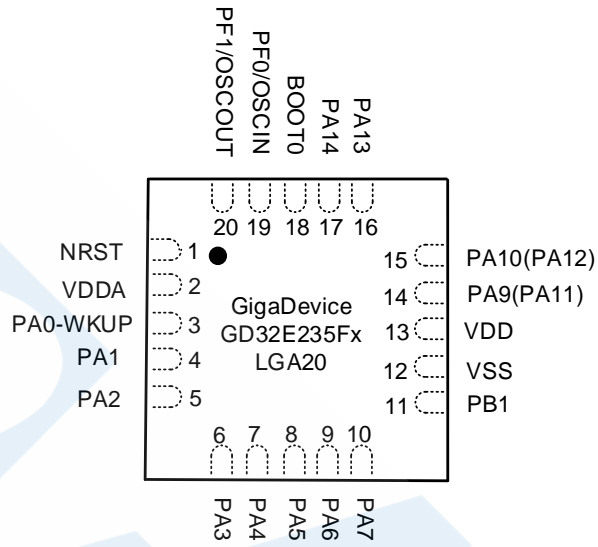

Figure 2-7. GD32E235Fx LGA20 pinouts



## 2.4 Memory map

**Table 2-3. GD32E235xx memory map**

Pre-defined Regions	Bus	ADDRESS	Peripherals
		0xE000 0000 - 0xE00F FFFF	Cortex M23 internal peripherals
External Device		0xA000 0000 - 0xDFFF FFFF	Reserved
External RAM		0x60000000 - 0x9FFFFFFF	Reserved
Peripherals	AHB1	0x5004 0000 - 0x5FFF FFFF	Reserved
		0x5000 0000 - 0x5003 FFFF	Reserved
	AHB2	0x4800 1800 - 0x4FFF FFFF	Reserved
		0x4800 1400 - 0x4800 17FF	GPIOF
		0x4800 1000 - 0x4800 13FF	Reserved
		0x4800 0C00 - 0x4800 0FFF	Reserved
		0x4800 0800 - 0x4800 0BFF	GPIOC
		0x4800 0400 - 0x4800 07FF	GPIOB
		0x4800 0000 - 0x4800 03FF	GPIOA
	AHB1	0x4002 4400 - 0x47FF FFFF	Reserved
		0x4002 4000 - 0x4002 43FF	Reserved
		0x4002 3400 - 0x4002 3FFF	Reserved
		0x4002 3000 - 0x4002 33FF	CRC
		0x4002 2400 - 0x4002 2FFF	Reserved
		0x4002 2000 - 0x4002 23FF	FMC
		0x4002 1400 - 0x4002 1FFF	Reserved
		0x4002 1000 - 0x4002 13FF	RCU
		0x4002 0400 - 0x4002 0FFF	Reserved
		0x4002 0000 - 0x4002 03FF	DMA
	APB2	0x4001 8000 - 0x4001 FFFF	Reserved
		0x4001 5C00 - 0x4001 7FFF	Reserved
		0x4001 5800 - 0x4001 5BFF	DBG
		0x4001 4C00 - 0x4001 57FF	Reserved
		0x4001 4800 - 0x4001 4BFF	TIMER16
		0x4001 4400 - 0x4001 47FF	TIMER15
		0x4001 4000 - 0x4001 43FF	TIMER14
		0x4001 3C00 - 0x4001 3FFF	Reserved
		0x4001 3800 - 0x4001 3BFF	USART0
		0x4001 3400 - 0x4001 37FF	Reserved
		0x4001 3000 - 0x4001 33FF	SPI0/I2S0
		0x4001 2C00 - 0x4001 2FFF	TIMER0
		0x4001 2800 - 0x4001 2BFF	Reserved
0x4001 2400 - 0x4001 27FF		ADC	
0x4001 0800 - 0x4001 23FF		Reserved	

Pre-defined Regions	Bus	ADDRESS	Peripherals
		0x4001 0400 - 0x4001 07FF	EXTI
		0x4001 0000 - 0x4001 03FF	SYSCFG + CMP
	APB1	0x4000 CC00 - 0x4000 FFFF	Reserved
		0x4000 C800 - 0x4000 CBFF	Reserved
		0x4000 C400 - 0x4000 C7FF	Reserved
		0x4000 C000 - 0x4000 C3FF	Reserved
		0x4000 8000 - 0x4000 BFFF	Reserved
		0x4000 7C00 - 0x4000 7FFF	Reserved
		0x4000 7800 - 0x4000 7BFF	Reserved
		0x4000 7400 - 0x4000 77FF	Reserved
		0x4000 7000 - 0x4000 73FF	PMU
		0x4000 6400 - 0x4000 6FFF	Reserved
		0x4000 6000 - 0x4000 63FF	Reserved
		0x4000 5C00 - 0x4000 5FFF	Reserved
		0x4000 5800 - 0x4000 5BFF	I2C1
		0x4000 5400 - 0x4000 57FF	I2C0
		0x4000 4800 - 0x4000 53FF	Reserved
		0x4000 4400 - 0x4000 47FF	USART1
		0x4000 4000 - 0x4000 43FF	Reserved
		0x4000 3C00 - 0x4000 3FFF	Reserved
		0x4000 3800 - 0x4000 3BFF	SPI1
		0x4000 3400 - 0x4000 37FF	Reserved
		0x4000 3000 - 0x4000 33FF	FWDGT
		0x4000 2C00 - 0x4000 2FFF	WWDGT
		0x4000 2800 - 0x4000 2BFF	RTC
		0x4000 2400 - 0x4000 27FF	Reserved
		0x4000 2000 - 0x4000 23FF	TIMER13
		0x4000 1400 - 0x4000 1FFF	Reserved
		0x4000 1000 - 0x4000 13FF	TIMER5
		0x4000 0800 - 0x4000 0FFF	Reserved
	0x4000 0400 - 0x4000 07FF	TIMER2	
	0x4000 0000 - 0x4000 03FF	Reserved	
SRAM		0x2000 4000 - 0x3FFF FFFF	Reserved
		0x2000 0000 - 0x2000 3FFF	SRAM
Code		0x1FFF F810 - 0x1FFF FFFF	Reserved
		0x1FFF F800 - 0x1FFF F80F	Option bytes
		0x1FFF EC00 - 0x1FFF F7FF	System memory
		0x0802 0000 - 0x1FFF EBFF	Reserved
		0x0800 0000 - 0x0801 FFFF	Main Flash memory
		0x0002 0000 - 0x07FF FFFF	Reserved



Pre-defined Regions	Bus	ADDRESS	Peripherals
		0x0000 0000 - 0x0001 FFFF	Aliased to Flash or system memory

## 2.5 Clock tree

Figure 2-8. GD32E235xx clock tree

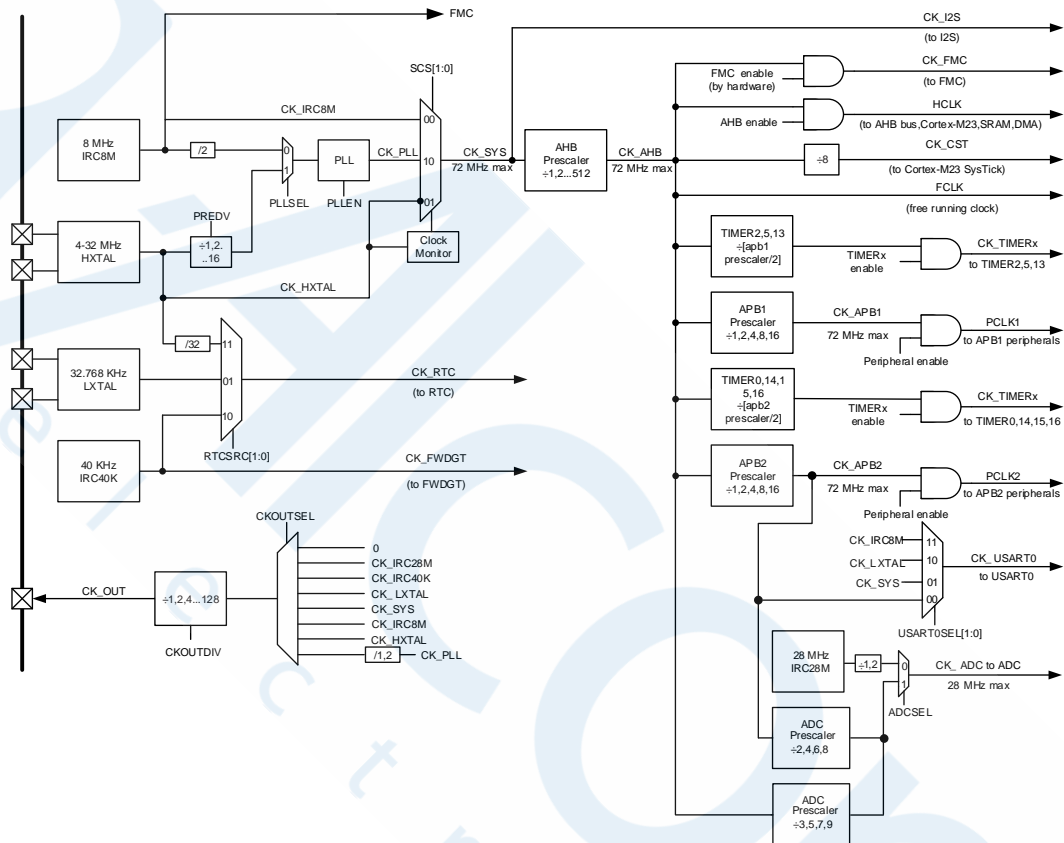

**Note:**

If the APB prescaler is 1, the timer clock frequencies are set to AHB frequency divide by 1. Otherwise, they are set to the AHB frequency divide by half of APB prescaler.

**Legend:**

- HXTAL: High speed crystal oscillator
- LXTAL: Low speed crystal oscillator
- IRC8M: Internal 8M RC oscillator
- IRC40K: Internal 40K RC oscillator
- IRC28M: Internal 28M RC oscillator

## 2.6 Pin definitions

### 2.6.1 GD32E235Cx LQFP48 pin definitions

Table 2-4. GD32E235Cx LQFP48 pin definitions

Pin Name	Pins	Pin Type <sup>(1)</sup>	I/O Level <sup>(2)</sup>	Functions description
V <sub>DD</sub>	1	P		Default: V <sub>DD</sub>
PC13-TAMPER-RTC	2	I/O		Default: PC13 Additional: RTC_TAMP0, RTC_TS, RTC_OUT, WKUP1
PC14-OSC32IN	3	I/O		Default: PC14 Additional: OSC32IN
PC15-OSC32OUT	4	I/O		Default: PC15 Additional: OSC32OUT
PF0/OSCIN	5	I/O	5VT	Default: PF0 Alternate: I2C0_SDA Additional: OSCIN
PF1/OSCOU T	6	I/O	5VT	Default: PF1 Alternate: I2C0_SCL Additional: OSCOUT
NRST	7	I/O		Default: NRST
VSSA	8	P		Default: VSSA
VDDA	9	P		Default: VDDA
PA0-WKUP	10	I/O		Default: PA0 Alternate: USART0_CTS <sup>(3)</sup> , USART1_CTS <sup>(4)</sup> , CMP_OUT, I2C1_SCL <sup>(5)</sup> Additional: ADC_IN0, CMP_IM6, RTC_TAMP1, WKUP0
PA1	11	I/O		Default: PA1 Alternate: USART0_RTS/USART0_DE <sup>(3)</sup> , USART1_RTS/USART1_DE <sup>(4)</sup> , I2C1_SDA <sup>(5)</sup> , EVENTOUT, TIMER14_CH0_ON <sup>(5)</sup> Additional: ADC_IN1, CMP_IP
PA2	12	I/O		Default: PA2 Alternate: USART0_TX <sup>(3)</sup> , USART1_TX <sup>(4)</sup> , TIMER14_CH0 <sup>(5)</sup> Additional: ADC_IN2, CMP_IM7
PA3	13	I/O		Default: PA3 Alternate: USART0_RX <sup>(3)</sup> , USART1_RX <sup>(4)</sup> , TIMER14_CH1 <sup>(5)</sup> Additional: ADC_IN3
PA4	14	I/O		Default: PA4 Alternate: SPI0_NSS, I2S0_WS, USART0_CK <sup>(3)</sup> , USART1_CK <sup>(4)</sup> , TIMER13_CH0, SPI1_NSS <sup>(5)</sup> Additional: ADC_IN4, CMP_IM4

Pin Name	Pins	Pin Type <sup>(1)</sup>	I/O Level <sup>(2)</sup>	Functions description
PA5	15	I/O		Default: PA5 Alternate: SPI0_SCK, I2S0_CK Additional: ADC_IN5, CMP_IM5
PA6	16	I/O		Default: PA6 Alternate: SPI0_MISO, I2S0_MCK, TIMER2_CH0, TIMER0_BRKIN, TIMER15_CH0, EVENTOUT, CMP_OUT Additional: ADC_IN6
PA7	17	I/O		Default: PA7 Alternate: SPI0_MOSI, I2S0_SD, TIMER2_CH1, TIMER13_CH0, TIMER0_CH0_ON, TIMER16_CH0, EVENTOUT Additional: ADC_IN7
PB0	18	I/O		Default: PB0 Alternate: TIMER2_CH2, TIMER0_CH1_ON, USART1_RX <sup>(4)</sup> , EVENTOUT Additional: ADC_IN8
PB1	19	I/O		Default: PB1 Alternate: TIMER2_CH3, TIMER13_CH0, TIMER0_CH2_ON, SPI1_SCK <sup>(5)</sup> Additional: ADC_IN9
PB2	20	I/O	5VT	Default: PB2 Alternate: TIMER2_ETI
PB10	21	I/O	5VT	Default: PB10 Alternate: I2C0_SCL <sup>(3)</sup> , I2C1_SCL <sup>(5)</sup> , SPI1_IO2 <sup>(5)</sup> , SPI1_SCK <sup>(5)</sup>
PB11	22	I/O	5VT	Default: PB11 Alternate: I2C0_SDA <sup>(3)</sup> , I2C1_SDA <sup>(5)</sup> , EVENTOUT, SPI1_IO3 <sup>(5)</sup>
VSS	23	P		Default: VSS
VDD	24	P		Default: VDD
PB12	25	I/O	5VT	Default: PB12 Alternate: SPI0_NSS <sup>(3)</sup> , SPI1_NSS <sup>(5)</sup> , TIMER0_BRKIN, I2C1_SMBA <sup>(5)</sup> , EVENTOUT
PB13	26	I/O	5VT	Default: PB13 Alternate: SPI0_SCK <sup>(3)</sup> , SPI1_SCK <sup>(5)</sup> , TIMER0_CH0_ON, I2C1_TXFRAME <sup>(5)</sup> , I2C1_SCL <sup>(5)</sup>
PB14	27	I/O	5VT	Default: PB14 Alternate: SPI0_MISO <sup>(3)</sup> , SPI1_MISO <sup>(5)</sup> , TIMER0_CH1_ON, TIMER14_CH0 <sup>(5)</sup> , I2C1_SDA <sup>(5)</sup>
PB15	28	I/O	5VT	Default: PB15 Alternate: SPI0_MOSI <sup>(3)</sup> , SPI1_MOSI <sup>(5)</sup> , TIMER0_CH2_ON, TIMER14_CH0_ON <sup>(5)</sup> , TIMER14_CH1 <sup>(5)</sup> Additional: RTC_REFIN, WKUP6

Pin Name	Pins	Pin Type <sup>(1)</sup>	I/O Level <sup>(2)</sup>	Functions description
PA8	29	I/O	5VT	Default: PA8 Alternate: USART0_CK, TIMER0_CH0, CK_OUT, USART1_TX <sup>(4)</sup> , EVENTOUT
PA9	30	I/O	5VT	Default: PA9 Alternate: USART0_TX, TIMER0_CH1, TIMER14_BRKIN <sup>(5)</sup> , I2C0_SCL, CK_OUT
PA10	31	I/O	5VT	Default: PA10 Alternate: USART0_RX, TIMER0_CH2, TIMER16_BRKIN, I2C0_SDA
PA11	32	I/O	5VT	Default: PA11 Alternate: USART0_CTS, TIMER0_CH3, CMP_OUT, EVENTOUT, SPI1_IO2 <sup>(5)</sup> , I2C0_SMBA, I2C1_SCL <sup>(5)</sup>
PA12	33	I/O	5VT	Default: PA12 Alternate: USART0_RTS/USART0_DE, TIMER0_ETI, EVENTOUT, SPI1_IO3 <sup>(5)</sup> , I2C0_TXFRAME, I2C1_SDA <sup>(5)</sup>
PA13	34	I/O	5VT	Default: PA13/SWDIO Alternate: SWDIO, IFRP_OUT, SPI1_MISO <sup>(5)</sup>
PF6	35	I/O	5VT	Default: PF6 Alternate: I2C0_SCL <sup>(3)</sup> , I2C1_SCL <sup>(5)</sup>
PF7	36	I/O	5VT	Default: PF7 Alternate: I2C0_SDA <sup>(3)</sup> , I2C1_SDA <sup>(5)</sup>
PA14	37	I/O	5VT	Default: PA14/SWCLK Alternate: USART0_TX <sup>(3)</sup> , USART1_TX <sup>(4)</sup> , SWCLK, SPI1_MOSI <sup>(5)</sup>
PA15	38	I/O	5VT	Default: PA15 Alternate: SPI0_NSS, I2S0_WS, USART0_RX <sup>(3)</sup> , USART1_RX <sup>(4)</sup> , SPI1_NSS <sup>(5)</sup> , EVENTOUT
PB3	39	I/O	5VT	Default: PB3 Alternate: SPI0_SCK, I2S0_CK, EVENTOUT
PB4	40	I/O	5VT	Default: PB4 Alternate: SPI0_MISO, I2S0_MCK, TIMER2_CH0, EVENTOUT, I2C0_TXFRAME, TIMER16_BRKIN
PB5	41	I/O	5VT	Default: PB5 Alternate: SPI0_MOSI, I2S0_SD, I2C0_SMBA, TIMER15_BRKIN, TIMER2_CH1 Additional: WKUP5
PB6	42	I/O	5VT	Default: PB6 Alternate: I2C0_SCL, USART0_TX, TIMER15_CH0_ON
PB7	43	I/O	5VT	Default: PB7 Alternate: I2C0_SDA, USART0_RX, TIMER16_CH0_ON
BOOT0	44	I		Default: BOOT0
PB8	45	I/O	5VT	Default: PB8 Alternate: I2C0_SCL, TIMER15_CH0
PB9	46	I/O	5VT	Default: PB9 Alternate: I2C0_SDA, IFRP_OUT, TIMER16_CH0,

Pin Name	Pins	Pin Type <sup>(1)</sup>	I/O Level <sup>(2)</sup>	Functions description
				EVENTOUT, I2S0_MCK, SPI1_NSS <sup>(5)</sup>
VSS	47	P		Default: VSS
VDD	48	P		Default: VDD

**Notes:**

- (1) Type: I = input, O = output, P = power.
- (2) I/O Level: 5VT = 5 V tolerant.
- (3) Functions are available on GD32E235C4 devices only.
- (4) Functions are available on GD32E235CB/8/6 devices.
- (5) Functions are available on GD32E235CB/8 devices only.

## 2.6.2 GD32E235Kx LQFP32 pin definitions

**Table 2-5. GD32E235Kx LQFP32 pin definitions**

Pin Name	Pins	Pin Type <sup>(1)</sup>	I/O Level <sup>(2)</sup>	Functions description
VDD	1	P		Default: VDD
PF0/OSCIN	2	I/O	5VT	Default: PF0 Alternate: I2C0_SDA Additional: OSCIN
PF1/OSCOU T	3	I/O	5VT	Default: PF1 Alternate: I2C0_SCL Additional: OSCOUT
NRST	4	I/O		Default: NRST
VDDA	5	P		Default: VDDA
PA0-WKUP	6	I/O		Default: PA0 Alternate: USART0_CTS <sup>(3)</sup> , USART1_CTS <sup>(4)</sup> , CMP_OUT, I2C1_SCL <sup>(5)</sup> Additional: ADC_IN0, CMP_IM6, RTC_TAMP1, WKUP0
PA1	7	I/O		Default: PA1 Alternate: USART0_RTS/USART0_DE <sup>(3)</sup> , USART1_RTS/USART1_DE <sup>(4)</sup> , I2C1_SDA <sup>(5)</sup> , EVENTOUT, TIMER14_CH0_ON <sup>(5)</sup> Additional: ADC_IN1, CMP_IP
PA2	8	I/O		Default: PA2 Alternate: USART0_TX <sup>(3)</sup> , USART1_TX <sup>(4)</sup> , TIMER14_CH0 <sup>(5)</sup> Additional: ADC_IN2, CMP_IM7
PA3	9	I/O		Default: PA3 Alternate: USART0_RX <sup>(3)</sup> , USART1_RX <sup>(4)</sup> , TIMER14_CH1 <sup>(5)</sup> Additional: ADC_IN3
PA4	10	I/O		Default: PA4 Alternate: SPI0_NSS, I2S0_WS, USART0_CK <sup>(3)</sup> ,

Pin Name	Pins	Pin Type <sup>(1)</sup>	I/O Level <sup>(2)</sup>	Functions description
				USART1_CK <sup>(4)</sup> , TIMER13_CH0, SPI1_NSS <sup>(5)</sup> Additional: ADC_IN4, CMP_IM4
PA5	11	I/O		Default: PA5 Alternate: SPI0_SCK, I2S0_CK Additional: ADC_IN5, CMP_IM5
PA6	12	I/O		Default: PA6 Alternate: SPI0_MISO, I2S0_MCK, TIMER2_CH0, TIMER0_BRKIN, TIMER15_CH0, EVENTOUT, CMP_OUT Additional: ADC_IN6
PA7	13	I/O		Default: PA7 Alternate: SPI0_MOSI, I2S0_SD, TIMER2_CH1, TIMER13_CH0, TIMER0_CH0_ON, TIMER16_CH0, EVENTOUT Additional: ADC_IN7
PB0	14	I/O		Default: PB0 Alternate: TIMER2_CH2, TIMER0_CH1_ON, USART1_RX <sup>(4)</sup> , EVENTOUT Additional: ADC_IN8
PB1	15	I/O		Default: PB1 Alternate: TIMER2_CH3, TIMER13_CH0, TIMER0_CH2_ON, SPI1_SCK <sup>(5)</sup> Additional: ADC_IN9
VSS	16	P		Default: VSS
VDD	17	P		Default: VDD
PA8	18	I/O	5VT	Default: PA8 Alternate: USART0_CK, TIMER0_CH0, CK_OUT, USART1_TX <sup>(4)</sup> , EVENTOUT
PA9	19	I/O	5VT	Default: PA9 Alternate: USART0_TX, TIMER0_CH1, TIMER14_BRKIN <sup>(5)</sup> , I2C0_SCL, CK_OUT
PA10	20	I/O	5VT	Default: PA10 Alternate: USART0_RX, TIMER0_CH2, TIMER16_BRKIN, I2C0_SDA
PA11	21	I/O	5VT	Default: PA11 Alternate: USART0_CTS, TIMER0_CH3, CMP_OUT, EVENTOUT, SPI1_IO2 <sup>(5)</sup> , I2C0_SMBA, I2C1_SCL <sup>(5)</sup>
PA12	22	I/O	5VT	Default: PA12 Alternate: USART0_RTS/USART0_DE, TIMER0_ETI, EVENTOUT, SPI1_IO3 <sup>(5)</sup> , I2C0_TXFRAME, I2C1_SDA <sup>(5)</sup>
PA13	23	I/O	5VT	Default: PA13/SWDIO Alternate: SWDIO, IFRP_OUT, SPI1_MISO <sup>(5)</sup>
PA14	24	I/O	5VT	Default: PA14/SWCLK Alternate: USART0_TX <sup>(3)</sup> , USART1_TX <sup>(4)</sup> , SWCLK, SPI1_MOSI <sup>(5)</sup>
PA15	25	I/O	5VT	Default: PA15

Pin Name	Pins	Pin Type <sup>(1)</sup>	I/O Level <sup>(2)</sup>	Functions description
				Alternate: SPI0_NSS, I2S0_WS, USART0_RX <sup>(3)</sup> , USART1_RX <sup>(4)</sup> , SPI1_NSS <sup>(5)</sup> , EVENTOUT
PB3	26	I/O	5VT	Default: PB3 Alternate: SPI0_SCK, I2S0_CK, EVENTOUT
PB4	27	I/O	5VT	Default: PB4 Alternate: SPI0_MISO, I2S0_MCK, TIMER2_CH0, EVENTOUT, I2C0_TXFRAME, TIMER16_BRKIN
PB5	28	I/O	5VT	Default: PB5 Alternate: SPI0_MOSI, I2S0_SD, I2C0_SMBA, TIMER15_BRKIN, TIMER2_CH1 Additional: WKUP5
PB6	29	I/O	5VT	Default: PB6 Alternate: I2C0_SCL, USART0_TX, TIMER15_CH0_ON
PB7	30	I/O	5VT	Default: PB7 Alternate: I2C0_SDA, USART0_RX, TIMER16_CH0_ON
BOOT0	31	I		Default: BOOT0
VSS	32	P		Default: VSS

**Notes:**

- (1) Type: I = input, O = output, P = power.
- (2) I/O Level: 5VT = 5 V tolerant.
- (3) Functions are available on GD32E235K4 devices only.
- (4) Functions are available on GD32E235KB/8/6 devices.
- (5) Functions are available on GD32E235KB/8 devices only.

### 2.6.3 GD32E235Kx QFN32 pin definitions

**Table 2-6. GD32E235Kx QFN32 pin definitions**

Pin Name	Pins	Pin Type <sup>(1)</sup>	I/O Level <sup>(2)</sup>	Functions description
VDD	1	P		Default: VDD
PF0/OSCIN	2	I/O	5VT	Default: PF0 Alternate: I2C0_SDA Additional: OSCIN
PF1/OSCOU T	3	I/O	5VT	Default: PF1 Alternate: I2C0_SCL Additional: OSCOUT
NRST	4	I/O		Default: NRST
VDDA	5	P		Default: VDDA
PA0-WKUP	6	I/O		Default: PA0 Alternate: USART0_CTS <sup>(3)</sup> , USART1_CTS <sup>(4)</sup> , CMP_OUT, I2C1_SCL <sup>(5)</sup> Additional: ADC_IN0, CMP_IM6, RTC_TAMP1, WKUP0
PA1	7	I/O		Default: PA1 Alternate: USART0_RTS/USART0_DE <sup>(3)</sup> ,

Pin Name	Pins	Pin Type <sup>(1)</sup>	I/O Level <sup>(2)</sup>	Functions description
				USART1_RTS/USART1_DE <sup>(4)</sup> , I2C1_SDA <sup>(5)</sup> , EVENTOUT, TIMER14_CH0_ON <sup>(5)</sup> Additional: ADC_IN1, CMP_IP
PA2	8	I/O		Default: PA2 Alternate: USART0_TX <sup>(3)</sup> , USART1_TX <sup>(4)</sup> , TIMER14_CH0 <sup>(5)</sup> Additional: ADC_IN2, CMP_IM7
PA3	9	I/O		Default: PA3 Alternate: USART0_RX <sup>(3)</sup> , USART1_RX <sup>(4)</sup> , TIMER14_CH1 <sup>(5)</sup> Additional: ADC_IN3
PA4	10	I/O		Default: PA4 Alternate: SPI0_NSS, I2S0_WS, USART0_CK <sup>(3)</sup> , USART1_CK <sup>(4)</sup> , TIMER13_CH0, SPI1_NSS <sup>(5)</sup> Additional: ADC_IN4, CMP_IM4
PA5	11	I/O		Default: PA5 Alternate: SPI0_SCK, I2S0_CK Additional: ADC_IN5, CMP_IM5
PA6	12	I/O		Default: PA6 Alternate: SPI0_MISO, I2S0_MCK, TIMER2_CH0, TIMER0_BRKIN, TIMER15_CH0, EVENTOUT, CMP_OUT Additional: ADC_IN6
PA7	13	I/O		Default: PA7 Alternate: SPI0_MOSI, I2S0_SD, TIMER2_CH1, TIMER13_CH0, TIMER0_CH0_ON, TIMER16_CH0, EVENTOUT Additional: ADC_IN7
PB0	14	I/O		Default: PB0 Alternate: TIMER2_CH2, TIMER0_CH1_ON, USART1_RX <sup>(4)</sup> , EVENTOUT Additional: ADC_IN8
PB1	15	I/O		Default: PB1 Alternate: TIMER2_CH3, TIMER13_CH0, TIMER0_CH2_ON, SPI1_SCK <sup>(5)</sup> Additional: ADC_IN9
PB2	16	I/O	5VT	Default: PB2 Alternate: TIMER2_ETI
VDD	17	P		Default: VDD
PA8	18	I/O	5VT	Default: PA8 Alternate: USART0_CK, TIMER0_CH0, CK_OUT, USART1_TX <sup>(4)</sup> , EVENTOUT
PA9	19	I/O	5VT	Default: PA9 Alternate: USART0_TX, TIMER0_CH1, TIMER14_BRKIN <sup>(5)</sup> , I2C0_SCL, CK_OUT
PA10	20	I/O	5VT	Default: PA10



Pin Name	Pins	Pin Type <sup>(1)</sup>	I/O Level <sup>(2)</sup>	Functions description
				Alternate: USART0_RX, TIMER0_CH2, TIMER16_BRKIN, I2C0_SDA
PA11	21	I/O	5VT	Default: PA11 Alternate: USART0_CTS, TIMER0_CH3, CMP_OUT, EVENTOUT, SPI1_IO2 <sup>(5)</sup> , I2C0_SMBA, I2C1_SCL <sup>(5)</sup>
PA12	22	I/O	5VT	Default: PA12 Alternate: USART0_RTS/USART0_DE, TIMER0_ETI, EVENTOUT, SPI1_IO3 <sup>(5)</sup> , I2C0_TXFRAME, I2C1_SDA <sup>(5)</sup>
PA13	23	I/O	5VT	Default: PA13/SWDIO Alternate: SWDIO, IFRP_OUT, SPI1_MISO <sup>(5)</sup>
PA14	24	I/O	5VT	Default: PA14/SWCLK Alternate: USART0_TX <sup>(3)</sup> , USART1_TX <sup>(4)</sup> , SWCLK, SPI1_MOSI <sup>(5)</sup>
PA15	25	I/O	5VT	Default: PA15 Alternate: SPI0_NSS, I2S0_WS, USART0_RX <sup>(3)</sup> , USART1_RX <sup>(4)</sup> , SPI1_NSS <sup>(5)</sup> , EVENTOUT
PB3	26	I/O	5VT	Default: PB3 Alternate: SPI0_SCK, I2S0_CK, EVENTOUT
PB4	27	I/O	5VT	Default: PB4 Alternate: SPI0_MISO, I2S0_MCK, TIMER2_CH0, EVENTOUT, I2C0_TXFRAME, TIMER16_BRKIN
PB5	28	I/O	5VT	Default: PB5 Alternate: SPI0_MOSI, I2S0_SD, I2C0_SMBA, TIMER15_BRKIN, TIMER2_CH1 Additional: WKUP5
PB6	29	I/O	5VT	Default: PB6 Alternate: I2C0_SCL, USART0_TX, TIMER15_CH0_ON
PB7	30	I/O	5VT	Default: PB7 Alternate: I2C0_SDA, USART0_RX, TIMER16_CH0_ON
BOOT0	31	I		Default: BOOT0
PB8	32	I/O	5VT	Default: PB8 Alternate: I2C0_SCL, TIMER15_CH0

**Notes:**

- (1) Type: I = input, O = output, P = power.
- (2) I/O Level: 5VT = 5 V tolerant.
- (3) Functions are available on GD32E235K4 devices only.
- (4) Functions are available on GD32E235KB/8/6 devices.
- (5) Functions are available on GD32E235KB/8 devices only.

**2.6.4 GD32E235Gx QFN28 pin definitions**
**Table 2-7. GD32E235Gx QFN28 pin definitions**

Pin Name	Pins	Pin Type <sup>(1)</sup>	I/O Level <sup>(2)</sup>	Functions description
BOOT0	1	I		Default: BOOT0
PF0/OSCIN	2	I/O	5VT	Default: PF0 Alternate: I2C0_SDA Additional: OSCIN
PF1/OSCOU T	3	I/O	5VT	Default: PF1 Alternate: I2C0_SCL Additional: OSCOUT
NRST	4	I/O		Default: NRST
VDDA	5	P		Default: VDDA
PA0-WKUP	6	I/O		Default: PA0 Alternate: USART0_CTS <sup>(3)</sup> , USART1_CTS <sup>(4)</sup> , CMP_OUT, I2C1_SCL <sup>(5)</sup> Additional: ADC_IN0, CMP_IM6, RTC_TAMP1, WKUP0
PA1	7	I/O		Default: PA1 Alternate: USART0_RTS/USART0_DE <sup>(3)</sup> , USART1_RTS/USART1_DE <sup>(4)</sup> , I2C1_SDA <sup>(5)</sup> , EVENTOUT, TIMER14_CH0_ON <sup>(6)</sup> Additional: ADC_IN1, CMP_IP
PA2	8	I/O		Default: PA2 Alternate: USART0_TX <sup>(3)</sup> , USART1_TX <sup>(4)</sup> , TIMER14_CH0 <sup>(5)</sup> Additional: ADC_IN2, CMP_IM7
PA3	9	I/O		Default: PA3 Alternate: USART0_RX <sup>(3)</sup> , USART1_RX <sup>(4)</sup> , TIMER14_CH1 <sup>(5)</sup> Additional: ADC_IN3
PA4	10	I/O		Default: PA4 Alternate: SPI0_NSS, I2S0_WS, USART0_CK <sup>(3)</sup> , USART1_CK <sup>(4)</sup> , TIMER13_CH0, SPI1_NSS <sup>(5)</sup> Additional: ADC_IN4, CMP_IM4
PA5	11	I/O		Default: PA5 Alternate: SPI0_SCK, I2S0_CK Additional: ADC_IN5, CMP_IM5
PA6	12	I/O		Default: PA6 Alternate: SPI0_MISO, I2S0_MCK, TIMER2_CH0, TIMER0_BRKIN, TIMER15_CH0, EVENTOUT, CMP_OUT Additional: ADC_IN6
PA7	13	I/O		Default: PA7 Alternate: SPI0_MOSI, I2S0_SD, TIMER2_CH1, TIMER13_CH0, TIMER0_CH0_ON, TIMER16_CH0, EVENTOUT

Pin Name	Pins	Pin Type <sup>(1)</sup>	I/O Level <sup>(2)</sup>	Functions description
				Additional: ADC_IN7
PB0	14	I/O		Default: PB0 Alternate: TIMER2_CH2, TIMER0_CH1_ON, USART1_RX <sup>(4)</sup> , EVENTOUT Additional: ADC_IN8
PB1	15	I/O		Default: PB1 Alternate: TIMER2_CH3, TIMER13_CH0, TIMER0_CH2_ON, SPI1_SCK <sup>(5)</sup> Additional: ADC_IN9
VSS	16	P		Default: VSS
VDD	17	P		Default: VDD
PA8	18	I/O	5VT	Default: PA8 Alternate: USART0_CK, TIMER0_CH0, CK_OUT, USART1_TX <sup>(4)</sup> , EVENTOUT
PA9 <sup>(6)</sup>	19	I/O	5VT	Default: PA9 Alternate: USART0_TX, TIMER0_CH1, TIMER14_BRKIN <sup>(5)</sup> , I2C0_SCL, CK_OUT
PA10 <sup>(6)</sup>	20	I/O	5VT	Default: PA10 Alternate: USART0_RX, TIMER0_CH2, TIMER16_BRKIN, I2C0_SDA
PA13	21	I/O	5VT	Default: PA13/SWDIO Alternate: SWDIO, IFRP_OUT, SPI1_MISO <sup>(5)</sup>
PA14	22	I/O	5VT	Default: PA14/SWCLK Alternate: USART0_TX <sup>(3)</sup> , USART1_TX <sup>(4)</sup> , SWCLK, SPI1_MOSI <sup>(5)</sup>
PA15	23	I/O	5VT	Default: PA15 Alternate: SPI0_NSS, I2S0_WS, USART0_RX <sup>(3)</sup> , USART1_RX <sup>(4)</sup> , SPI1_NSS <sup>(5)</sup> , EVENTOUT
PB3	24	I/O	5VT	Default: PB3 Alternate: SPI0_SCK, I2S0_CK, EVENTOUT
PB4	25	I/O	5VT	Default: PB4 Alternate: SPI0_MISO, I2S0_MCK, TIMER2_CH0, EVENTOUT, I2C0_TXFRAME, TIMER16_BRKIN
PB5	26	I/O	5VT	Default: PB5 Alternate: SPI0_MOSI, I2S0_SD, I2C0_SMBA, TIMER15_BRKIN, TIMER2_CH1 Additional: WKUP5
PB6	27	I/O	5VT	Default: PB6 Alternate: I2C0_SCL, USART0_TX, TIMER15_CH0_ON
PB7	28	I/O	5VT	Default: PB7 Alternate: I2C0_SDA, USART0_RX, TIMER16_CH0_ON

**Notes:**

- (1) Type: I = input, O = output, P = power.
- (2) I/O Level: 5VT = 5 V tolerant.
- (3) Functions are available on GD32E235G4 devices only.

- (4) Functions are available on GD32E235G8/6 devices.
- (5) Functions are available on GD32E235G8 devices only.
- (6) Pin pair PA11/PA12 can be remapped instead of pin pair PA9/PA10 using SYSCFG\_CFG0 register. [Table 2-10. Port A alternate functions summary](#) shows PA11/PA12 remap.

## 2.6.5 GD32E235Fx TSSOP20 pin definitions

Table 2-8. GD32E235Fx TSSOP20 pin definitions

Pin Name	Pins	Pin Type <sup>(1)</sup>	I/O Level <sup>(2)</sup>	Functions description
PF0/OSCIN	2	I/O	5VT	Default: PF0 Alternate: I2C0_SDA Additional: OSCIN
PF1/OSCOU T	3	I/O	5VT	Default: PF1 Alternate: I2C0_SCL Additional: OSCOUT
NRST	4	I/O		Default: NRST
VDDA	5	P		Default: VDDA
PA0-WKUP	6	I/O		Default: PA0 Alternate: USART0_CTS <sup>(3)</sup> , USART1_CTS <sup>(4)</sup> , CMP_OUT, I2C1_SCL <sup>(5)</sup> Additional: ADC_IN0, CMP_IM6, RTC_TAMP1, WKUP0
PA1	7	I/O		Default: PA1 Alternate: USART0_RTS/USART0_DE <sup>(3)</sup> , USART1_RTS/USART1_DE <sup>(4)</sup> , I2C1_SDA <sup>(5)</sup> , EVENTOUT Additional: ADC_IN1, CMP_IP
PA2	8	I/O		Default: PA2 Alternate: USART0_TX <sup>(3)</sup> , USART1_TX <sup>(4)</sup> Additional: ADC_IN2, CMP_IM7
PA3	9	I/O		Default: PA3 Alternate: USART0_RX <sup>(3)</sup> , USART1_RX <sup>(4)</sup> Additional: ADC_IN3
PA4	10	I/O		Default: PA4 Alternate: SPI0_NSS, I2S0_WS, USART0_CK <sup>(3)</sup> , USART1_CK <sup>(4)</sup> , TIMER13_CH0, SPI1_NSS <sup>(5)</sup> Additional: ADC_IN4, CMP_IM4
PA5	11	I/O		Default: PA5 Alternate: SPI0_SCK, I2S0_CK Additional: ADC_IN5, CMP_IM5
PA6	12	I/O		Default: PA6 Alternate: SPI0_MISO, I2S0_MCK, TIMER2_CH0, TIMER0_BRKIN, TIMER15_CH0, EVENTOUT, CMP_OUT Additional: ADC_IN6
PA7	13	I/O		Default: PA7

Pin Name	Pins	Pin Type <sup>(1)</sup>	I/O Level <sup>(2)</sup>	Functions description
				Alternate: SPI0_MOSI, I2S0_SD, TIMER2_CH1, TIMER13_CH0, TIMER0_CH0_ON, TIMER16_CH0, EVENTOUT Additional: ADC_IN7
PB1	14	I/O		Default: PB1 Alternate: TIMER2_CH3, TIMER13_CH0, TIMER0_CH2_ON, SPI1_SCK <sup>(5)</sup> Additional: ADC_IN9
VSS	15	P		Default: VSS
VDD	16	P		Default: VDD
PA9 <sup>(6)</sup>	17	I/O	5VT	Default: PA9 Alternate: USART0_TX, TIMER0_CH1, I2C0_SCL, CK_OUT
PA10 <sup>(6)</sup>	18	I/O	5VT	Default: PA10 Alternate: USART0_RX, TIMER0_CH2, TIMER16_BRKIN, I2C0_SDA
PA13	19	I/O	5VT	Default: PA13/SWDIO Alternate: SWDIO, IFRP_OUT, SPI1_MISO <sup>(5)</sup>
PA14	20	I/O	5VT	Default: PA14/SWCLK Alternate: USART0_TX <sup>(3)</sup> , USART1_TX <sup>(4)</sup> , SWCLK, SPI1_MOSI <sup>(5)</sup>
BOOT0	1	I		Default: BOOT0

**Notes:**

- (1) Type: I = input, O = output, P = power.
- (2) I/O Level: 5VT = 5 V tolerant.
- (3) Functions are available on GD32E235F4 devices only.
- (4) Functions are available on GD32E235F8/6 devices.
- (5) Functions are available on GD32E235F8 devices only.
- (6) Pin pair PA11/PA12 can be remapped instead of pin pair PA9/PA10 using SYSCFG\_CFG0 register. [Table 2-10. Port A alternate functions summary](#) shows PA11/PA12 remap.

## 2.6.6 GD32E235Fx LGA20 pin definitions

**Table 2-9. GD32E235Fx LGA20 pin definitions**

Pin Name	Pins	Pin Type <sup>(1)</sup>	I/O Level <sup>(2)</sup>	Functions description
PF0/OSCIN	19	I/O	5VT	Default: PF0 Alternate: I2C0_SDA Additional: OSCIN
PF1/OSCOU T	20	I/O	5VT	Default: PF1 Alternate: I2C0_SCL Additional: OSCOUT
NRST	1	I/O		Default: NRST

Pin Name	Pins	Pin Type <sup>(1)</sup>	I/O Level <sup>(2)</sup>	Functions description
VDDA	2	P		Default: VDDA
PA0-WKUP	3	I/O		Default: PA0 Alternate: USART0_CTS <sup>(3)</sup> , USART1_CTS <sup>(4)</sup> , CMP_OUT, I2C1_SCL <sup>(5)</sup> Additional: ADC_IN0, CMP_IM6, RTC_TAMP1, WKUP0
PA1	4	I/O		Default: PA1 Alternate: USART0_RTS/USART0_DE <sup>(3)</sup> , USART1_RTS/USART1_DE <sup>(4)</sup> , I2C1_SDA <sup>(5)</sup> , EVENTOUT Additional: ADC_IN1, CMP_IP
PA2	5	I/O		Default: PA2 Alternate: USART0_TX <sup>(3)</sup> , USART1_TX <sup>(4)</sup> Additional: ADC_IN2, CMP_IM7
PA3	6	I/O		Default: PA3 Alternate: USART0_RX <sup>(3)</sup> , USART1_RX <sup>(4)</sup> Additional: ADC_IN3
PA4	7	I/O		Default: PA4 Alternate: SPI0_NSS, I2S0_WS, USART0_CK <sup>(3)</sup> , USART1_CK <sup>(4)</sup> , TIMER13_CH0, SPI1_NSS <sup>(5)</sup> Additional: ADC_IN4, CMP_IM4
PA5	8	I/O		Default: PA5 Alternate: SPI0_SCK, I2S0_CK Additional: ADC_IN5, CMP_IM5
PA6	9	I/O		Default: PA6 Alternate: SPI0_MISO, I2S0_MCK, TIMER2_CH0, TIMER0_BRKIN, TIMER15_CH0, EVENTOUT, CMP_OUT Additional: ADC_IN6
PA7	10	I/O		Default: PA7 Alternate: SPI0_MOSI, I2S0_SD, TIMER2_CH1, TIMER13_CH0, TIMER0_CH0_ON, TIMER16_CH0, EVENTOUT Additional: ADC_IN7
PB1	11	I/O		Default: PB1 Alternate: TIMER2_CH3, TIMER13_CH0, TIMER0_CH2_ON, SPI1_SCK <sup>(5)</sup> Additional: ADC_IN9
VSS	12	P		Default: VSS
VDD	13	P		Default: VDD
PA9 <sup>(6)</sup>	14	I/O	5VT	Default: PA9 Alternate: USART0_TX, TIMER0_CH1, I2C0_SCL, CK_OUT
PA10 <sup>(6)</sup>	15	I/O	5VT	Default: PA10 Alternate: USART0_RX, TIMER0_CH2, TIMER16_BRKIN, I2C0_SDA

Pin Name	Pins	Pin Type <sup>(1)</sup>	I/O Level <sup>(2)</sup>	Functions description
PA13	16	I/O	5VT	Default: PA13/SWDIO Alternate: SWDIO, IFRP_OUT, SPI1_MISO <sup>(5)</sup>
PA14	17	I/O	5VT	Default: PA14/SWCLK Alternate: USART0_TX <sup>(3)</sup> , USART1_TX <sup>(4)</sup> , SWCLK, SPI1_MOSI <sup>(5)</sup>
BOOT0	18	I		Default: BOOT0

**Notes:**

- (1) Type: I = input, O = output, P = power.
- (2) I/O Level: 5VT = 5 V tolerant.
- (3) Functions are available on GD32E235F4 devices only.
- (4) Functions are available on GD32E235F8/6 devices.
- (5) Functions are available on GD32E235F8 devices only.
- (6) Pin pair PA11/PA12 can be remapped instead of pin pair PA9/PA10 using SYSCFG\_CFG0 register. [Table 2-10. Port A alternate functions summary](#) shows PA11/PA12 remap.

## 2.6.7 GD32E235xx pin alternate functions

**Table 2-10. Port A alternate functions summary**

Pin Name	AF0	AF1	AF2	AF3	AF4	AF5	AF6	AF7
PA0		USART0_CTS <sup>(1)</sup> /USART1_CTS <sup>(2)</sup>			I2C1_SCL <sup>(3)</sup>			CMP_OUT
PA1	EVENTOUT	USART0_RTS <sup>(1)</sup> /USART0_DE <sup>(1)</sup> USART1_RTS <sup>(2)</sup> /USART1_DE <sup>(2)</sup>			I2C1_SDA <sup>(3)</sup>	TIMER14_CH0_ON <sup>(3)</sup>		
PA2	TIMER14_CH0 <sup>(3)</sup>	USART0_TX <sup>(1)</sup> USART1_TX <sup>(2)</sup>						
PA3	TIMER14_CH1 <sup>(3)</sup>	USART0_RX <sup>(1)</sup> USART1_RX <sup>(2)</sup>						
PA4	SPI0_NSS/I2S0_WS	USART0_CK <sup>(1)</sup> USART1_CK <sup>(2)</sup>			TIMER13_CH0		SPI1_NSS <sup>(3)</sup>	
PA5	SPI0_SCK/I2S0_CK							
PA6	SPI0_MISO/I2S0_MCK	TIMER2_CH0	TIMER0_BRKIN			TIMER15_CH0	EVENT_OUT	CMP_OUT
PA7	SPI0_MOSI/I2S0_SD	TIMER2_CH1	TIMER0_CH0_ON		TIMER13_CH0	TIMER16_CH0	EVENT_OUT	
PA8	CK_OUT	USART0_CK	TIMER0_CH0	EVENT_OUT	USART1_TX <sup>(2)</sup>			
PA9	TIMER14_BRKIN <sup>(3)</sup>	USART0_TX	TIMER0_CH1		I2C0_SCL	CK_OUT		
PA10	TIMER16_BRKIN	USART0_RX	TIMER0_CH2		I2C0_SDA			
PA11	EVENTOUT	USART0_CTS	TIMER0_CH3		I2C0_SMB_A	I2C1_SCL <sup>(3)</sup>	SPI1_I/O2 <sup>(3)</sup>	CMP_OUT
PA12	EVENTOUT	USART0_RTS/USART0_DE	TIMER0_ETI		I2C0_TXF_RAME	I2C1_SDA <sup>(3)</sup>	SPI1_I/O3 <sup>(3)</sup>	
PA13	SWDIO	IFRP_OUT					SPI1_MISO <sup>(3)</sup>	
PA14	SWCLK	USART0_TX <sup>(1)</sup> USART1_TX <sup>(2)</sup>					SPI1_MOSI <sup>(3)</sup>	
PA15	SPI0_NSS/I2S0_WS	USART0_RX <sup>(1)</sup> USART1_RX <sup>(2)</sup>		EVENT_OUT			SPI1_NSS <sup>(3)</sup>	



**Table 2-11. Port B alternate functions summary**

Pin Name	AF0	AF1	AF2	AF3	AF4	AF5	AF6	AF7
PB0	EVENTOUT	TIMER2_CH2	TIMER0_CH1_ON		USART1_RX <sup>(2)</sup>			
PB1	TIMER13_CH0	TIMER2_CH3	TIMER0_CH2_ON				SPI1_SCK <sup>(3)</sup>	
PB2		TIMER2_ETI						
PB3	SPI0_SCK/I2S0_S0_CK	EVENTOUT						
PB4	SPI0_MISO/I2S0_MCK	TIMER2_CH0	EVENTOUT		I2C0_TX FRAME		TIMER16_BRKIN	
PB5	SPI0_MOSI/I2S0_SD	TIMER2_CH1	TIMER15_BRKIN	I2C0_SMBA				
PB6	USART0_TX	I2C0_SCL	TIMER15_CH0_ON					
PB7	USART0_RX	I2C0_SDA	TIMER16_CH0_ON					
PB8		I2C0_SCL	TIMER15_CH0					
PB9	IFRP_OUT	I2C0_SDA	TIMER16_CH0	EVENTOUT		I2S0_MCK		SPI1_NSS <sup>(3)</sup>
PB10		I2C0_SCL <sup>(1)</sup> /I2C1_SCL <sup>(3)</sup>					SPI1_IO2 <sup>(3)</sup>	SPI1_SCK <sup>(3)</sup>
PB11	EVENTOUT	I2C0_SDA <sup>(1)</sup> /I2C1_SDA <sup>(3)</sup>					SPI1_IO3 <sup>(3)</sup>	
PB12	SPI0_NSS <sup>(1)</sup> /SPI1_NSS <sup>(3)</sup>	EVENTOUT	TIMER0_BRKIN		I2C1_SMBA <sup>(3)</sup>			
PB13	SPI0_SCK <sup>(1)</sup> /SPI1_SCK <sup>(3)</sup>	I2C1_TXFRAME <sup>(3)</sup>	TIMER0_CH0_ON			I2C1_SCL <sup>(3)</sup>		
PB14	SPI0_MISO <sup>(1)</sup> /SPI1_MISO <sup>(3)</sup>	TIMER14_CH0 <sup>(3)</sup>	TIMER0_CH1_ON			I2C1_SDA <sup>(3)</sup>		
PB15	SPI0_MOSI <sup>(1)</sup> /SPI1_MOSI <sup>(3)</sup>	TIMER14_CH1 <sup>(3)</sup>	TIMER0_CH2_ON	TIMER14_CH0_ON <sup>(3)</sup>				

**Table 2-12. Port F alternate functions summary**

Pin Name	AF0	AF1	AF2	AF3	AF4	AF5	AF6
PF0		I2C0_SDA					
PF1		I2C0_SCL					
PF6	I2C0_SCL <sup>(1)</sup> /I2C1_SCL						

Pin Name	AF0	AF1	AF2	AF3	AF4	AF5	AF6
	(3)						
PF7	I2C0_SDA(1)/I2C1_SDA(3)						

**Notes:**

- (1) Functions are available on GD32E235x4 devices only.
- (2) Functions are available on GD32E235xB/8/6 devices.
- (3) Functions are available on GD32E235xB/8 devices only.

## 3 Functional description

### 3.1 ARM® Cortex®-M23 core

The Cortex-M23 processor is an energy-efficient processor with a very low gate count. It is intended to be used for microcontroller and deeply embedded applications that require an area-optimized processor. The processor is highly configurable enabling a wide range of implementations from those requiring memory protection to cost sensitive devices requiring minimal area, while delivering outstanding computational performance and an advanced system response to interrupts.

32-bit ARM® Cortex®-M23 processor core

- Up to 72 MHz operation frequency
- Single-cycle multiplication and hardware divider
- Ultra-low power, energy-efficient operation
- Excellent code density
- Integrated Nested Vectored Interrupt Controller (NVIC)
- 24-bit SysTick timer

The Cortex®-M23 processor is based on the ARMv8-M architecture and supports both Thumb and Thumb-2 instruction sets. Some system peripherals listed below are also provided by Cortex®-M23:

- Internal Bus Matrix connected with AHB master, Serial Wire Debug Port and Single-cycle IO port
- Nested Vectored Interrupt Controller (NVIC)
- Breakpoint Unit(BPU)
- Data Watchpoint
- Serial Wire Debug Port

### 3.2 Embedded memory

- Up to 128 Kbytes of Flash memory
- Up to 16 Kbytes of SRAM with hardware parity checking

128 Kbytes of inner Flash and 16 Kbytes of inner SRAM at most is available for storing programs and data, and Flash is accessed (read) at CPU clock speed with 0~2 wait states.

[Table 2-3. GD32E235xx memory map](#) shows the memory map of the GD32E235xx series of devices, including code, SRAM, peripheral, and other pre-defined regions.

### 3.3 Clock, reset and supply management

- Internal 8 MHz factory-trimmed RC and external 4 to 32 MHz crystal oscillator

- Internal 28 MHz RC oscillator
- Internal 40 KHz RC calibrated oscillator and external 32.768 KHz crystal oscillator
- Integrated system clock PLL
- 1.8 to 3.6 V application supply and I/Os
- Supply Supervisor: POR (Power On Reset), PDR (Power Down Reset), and low voltage detector (LVD)

The Clock Control Unit (CCU) provides a range of oscillator and clock functions. These include speed internal RC oscillator and external crystal oscillator, high speed and low speed two types. Several prescalers allow the frequency configuration of the AHB and two APB domains. The maximum frequency of the AHB, APB2 and APB1 domains is 72 MHz/72 MHz/72 MHz. See [Figure 2-8. GD32E235xx clock tree](#) for details on the clock tree.

The Reset Control Unit (RCU) controls three kinds of reset: system reset resets the processor core and peripheral IP components. Power-on reset (POR) and power-down reset (PDR) are always active, and ensures proper operation starting from 1.71 V and down to 1.67 V. The device remains in reset mode when  $V_{DD}$  is below a specified threshold. The embedded low voltage detector (LVD) monitors the power supply, compares it to the voltage threshold and generates an interrupt as a warning message for leading the MCU into security.

Power supply schemes:

- $V_{DD}$  range: 1.8 to 3.6 V, external power supply for I/Os and the internal regulator. Provided externally through  $V_{DD}$  pins.
- $V_{SSA}$ ,  $V_{DDA}$  range: 1.8 to 3.6 V, external analog power supplies for ADC, reset blocks, RCs and PLL.  $V_{DDA}$  and  $V_{SSA}$  must be connected to  $V_{DD}$  and  $V_{SS}$ , respectively.
- $V_{BAK}$  range: 1.8 to 3.6 V, power supply for RTC, external clock 32 KHz oscillator and backup registers (through power switch) when  $V_{DD}$  is not present.

### 3.4 Boot modes

At startup, boot pins are used to select one of three boot options:

- Boot from main Flash memory (default)
- Boot from system memory
- Boot from on-chip SRAM

In default condition, boot from main Flash memory is selected. The boot loader is located in the internal boot ROM memory (system memory). It is used to reprogram the Flash memory by using USART0 (PA9 and PA10) or USART1 (PA14 and PA15 or PA2 and PA3).

### 3.5 Power saving modes

The MCU supports three kinds of power saving modes to achieve even lower power consumption. They are sleep mode, deep-sleep mode, and standby mode. These operating modes reduce the power consumption and allow the application to achieve the best balance

between the CPU operating time, speed and power consumption.

■ **Sleep mode**

In sleep mode, only the clock of CPU core is off. All peripherals continue to operate and any interrupt/event can wake up the system.

■ **Deep-sleep mode**

In deep-sleep mode, all clocks in the 1.2V domain are off, and all of the high speed crystal oscillator (IRC8M, HXTAL) and PLL are disabled. Only the contents of SRAM and registers are retained. Any interrupt or wakeup event from EXTI lines can wake up the system from the deep-sleep mode including the 16 external lines, the RTC alarm, RTC tamper and timestamp, CMP output, LVD output and USART wakeup. When exiting the deep-sleep mode, the IRC8M is selected as the system clock.

■ **Standby mode**

In standby mode, the whole 1.2V domain is power off, the LDO is shut down, and all of IRC8M, HXTAL and PLL are disabled. The contents of SRAM and registers (except backup registers) are lost. There are four wakeup sources for the standby mode, including the external reset from NRST pin, the RTC alarm, the FWDGT reset, and the rising edge on WKUP pin.

### 3.6 Analog to digital converter (ADC)

- 12-bit SAR ADC's conversion rate is up to 2 MSPS
- 12-bit, 10-bit, 8-bit or 6-bit configurable resolution
- Hardware oversampling ratio adjustable from 2 to 256x improves resolution to 16-bit
- Input voltage range:  $V_{SSA}$  to  $V_{DDA}$
- Temperature sensor

One 12-bit 2 MSPS multi-channel ADC is integrated in the device. It has a total of 12 multiplexed channels: up to 10 external channels, 1 channel for internal temperature sensor ( $V_{SENSE}$ ) and 1 channel for internal reference voltage ( $V_{REFINT}$ ). The input voltage range is between  $V_{SSA}$  and  $V_{DDA}$ . An on-chip hardware oversampling scheme improves performance while off-loading the related computational burden from the CPU. An analog watchdog block can be used to detect the channels, which are required to remain within a specific threshold window. A configurable channel management block can be used to perform conversions in single, continuous, scan or discontinuous mode to support more advanced use.

The ADC can be triggered from the events generated by the general level 0 timers (TIMERx) and the advanced timer (TIMER0) with internal connection. The temperature sensor can be used to generate a voltage that varies linearly with temperature. It is internally connected to the ADC\_IN16 input channel which is used to convert the sensor output voltage in a digital value.

### 3.7 DMA

- 5 channels DMA controller
- Peripherals supported: Timers, ADC, SPIs, I2Cs, USARTs and I2S

The flexible general-purpose DMA controllers provide a hardware method of transferring data between peripherals and/or memory without intervention from the CPU, thereby freeing up bandwidth for other system functions. Three types of access method are supported: peripheral to memory, memory to peripheral, memory to memory.

Each channel is connected to fixed hardware DMA requests. The priorities of DMA channel requests are determined by software configuration and hardware channel number. Transfer size of source and destination are independent and configurable.

### 3.8 General-purpose inputs/outputs (GPIOs)

- Up to 39 fast GPIOs, all mappable on 16 external interrupt lines
- Analog input/output configurable
- Alternate function input/output configurable

There are up to 39 general purpose I/O pins (GPIO) in GD32E235xx, named PA0 ~ PA15 and PB0 ~ PB15, PC13 ~ PC15, PF0 ~ PF1, PF6 ~ PF7 to implement logic input/output functions. Each of the GPIO ports has related control and configuration registers to satisfy the requirements of specific applications. The external interrupts on the GPIO pins of the device have related control and configuration registers in the Interrupt/event controller (EXTI). The GPIO ports are pin-shared with other alternative functions (AFs) to obtain maximum flexibility on the package pins. Each of the GPIO pins can be configured by software as output (push-pull open-drain or analog), as input (with or without pull-up or pull-down) or as peripheral alternate function. Most of the GPIO pins are shared with digital or analog alternate functions. All GPIOs are high-current capable except for analog inputs.

### 3.9 Timers and PWM generation

- One 16-bit advanced timer (TIMER0), up to five 16-bit general timers (TIMER2, TIMER13 ~ TIMER16), and one 16-bit basic timer (TIMER5)
- Up to 4 independent channels of PWM, output compare or input capture for each general timer and external trigger input
- 16-bit, motor control PWM advanced timer with programmable dead-time generation for output match
- Encoder interface controller with two inputs using quadrature decoder
- 24-bit SysTick timer down counter
- 2 watchdog timers (free watchdog timer and window watchdog timer)

The advanced timer (TIMER0) can be used as a three-phase PWM multiplexed on 6 channels.

It has complementary PWM outputs with programmable dead-time generation. It can also be used as a complete general timer. The 4 independent channels can be used for input capture, output compare, PWM generation (edge- or center- aligned counting modes) and single pulse mode output. If configured as a general 16-bit timer, it has the same functions as the TIMExx timer. It can be synchronized with external signals or to interconnect with other general timers together which have the same architecture and features.

The general timer can be used for a variety of purposes including general time, input signal pulse width measurement or output waveform generation such as a single pulse generation or PWM output, up to 4 independent channels for input capture/output compare. TIMER2 is based on a 16-bit auto-reload up/down counter and a 16-bit prescaler. TIMER13 ~ TIMER16 is based on a 16-bit auto-reload up counter and a 16-bit prescaler. The general timer also supports an encoder interface with two inputs using quadrature decoder.

The basic timer, known as TIMER5 can also be used as a simple 16-bit time base.

The GD32E235xx have two watchdog peripherals, free watchdog and window watchdog. They offer a combination of high safety level, flexibility of use and timing accuracy.

The free watchdog timer includes a 12-bit down-counting counter and an 8-bit prescaler. It is clocked from an independent 40 KHz internal RC and as it operates independently of the main clock, it can operate in deep-sleep and standby modes. It can be used either as a watchdog to reset the device when a problem occurs, or as a free-running timer for application timeout management.

The window watchdog is based on a 7-bit down counter that can be set as free-running. It can be used as a watchdog to reset the device when a problem occurs. It is clocked from the main clock. It has an early wakeup interrupt capability and the counter can be frozen in debug mode.

The SysTick timer is dedicated for OS, but could also be used as a standard down counter. The features are shown below:

- A 24-bit down counter
- Auto reload capability
- Maskable system interrupt generation when the counter reaches 0
- Programmable clock source

### 3.10 Real time clock (RTC)

- Independent binary-coded decimal (BCD) format timer/counter with five 32-bit backup registers.
- Calendar with subsecond, second, minute, hour, week day, date, year and month automatically correction
- Alarm function with wake up from deep-sleep and standby mode capability
- On-the-fly correction for synchronization with master clock. Digital calibration with 0.954 ppm resolution for compensation of quartz crystal inaccuracy.

The real time clock is an independent timer which provides a set of continuously running counters in backup registers to provide a real calendar function, and provides an alarm interrupt or an expected interrupt. It is not reset by a system or power reset, or when the device wakes up from standby mode. In the RTC unit, there are two prescalers used for implementing the calendar and other functions. One prescaler is a 7-bit asynchronous prescaler and the other is a 15-bit synchronous prescaler.

### 3.11 Inter-integrated circuit (I2C)

- Up to two I2C bus interfaces can support both master and slave mode with a frequency up to 1 MHz (Fast mode plus)
- Provide arbitration function, optional PEC (packet error checking) generation and checking
- Supports 7-bit and 10-bit addressing mode and general call addressing mode
- Supports SAM\_V mode

The I2C interface is an internal circuit allowing communication with an external I2C interface which is an industry standard two line serial interface used for connection to external hardware. These two serial lines are known as a serial data line (SDA) and a serial clock line (SCL). The I2C module provides different data transfer rates: up to 100 KHz in standard mode, up to 400 KHz in the fast mode and up to 1 MHz in the fast mode plus. The I2C module also has an arbitration detect function to prevent the situation where more than one master attempts to transmit data to the I2C bus at the same time. A CRC-8 calculator is also provided in I2C interface to perform packet error checking for I2C data.

### 3.12 Serial peripheral interface (SPI)

- Up to two SPI interfaces with a frequency of up to 18 MHz
- Support both master and slave mode
- Hardware CRC calculation and transmit automatic CRC error checking
- Separate transmit and receive 32-bit FIFO with DMA capability (only in SPI1)
- Data frame size can be 4 to 16 bits (only in SPI1)
- Quad-SPI configuration available in master mode (only in SPI1)

The SPI interface uses 4 pins, among which are the serial data input and output lines (MISO & MOSI), the clock line (SCK) and the slave select line (NSS). Both SPIs can be served by the DMA controller. The SPI interface may be used for a variety of purposes, including simplex synchronous transfers on two lines with a possible bidirectional data line or reliable communication using CRC checking. Specially, SPI1 has separate transmit and receive 32-bit FIFO with DMA capability and its data frame size can be 4 to 16 bits. Quad-SPI master mode is also supported in SPI1.



### 3.13 Universal synchronous asynchronous receiver transmitter (USART)

- Up to two USARTs with operating frequency up to 4.5 MBits/s
- Supports both asynchronous and clocked synchronous serial communication modes
- IrDA SIR encoder and decoder support
- LIN break generation and detection
- ISO 7816-3 compliant smart card interface

The USART (USART0, USART1) are used to translate data between parallel and serial interfaces, provides a flexible full duplex data exchange using synchronous or asynchronous transfer. It is also commonly used for RS-232 standard communication. The USART includes a programmable baud rate generator which is capable of dividing the system clock to produce a dedicated clock for the USART transmitter and receiver. The USART also supports DMA function for high speed data communication.

### 3.14 Inter-IC sound (I2S)

- One I2S bus Interfaces with sampling frequency from 8 KHz to 192 KHz, multiplexed with SPI0
- Support either master or slave mode

The Inter-IC sound (I2S) bus provides a standard communication interface for digital audio applications by 3-wire serial lines. GD32E235xx contain an I2S-bus interface that can be operated with 16/32 bit resolution in master or slave mode, pin multiplexed with SPI0. The audio sampling frequency from 8 KHz to 192 KHz is supported with less than 0.5% accuracy error.

### 3.15 Comparators (CMP)

- One fast rail-to-rail low-power comparators with software configurable
- Programmable reference voltage (internal or external I/O)

One Comparator (CMP) is implemented within the devices. It can wake up from deep-sleep mode to generate interrupts and breaks for the timers and also can be combined as a window comparator. The internal voltage reference is also connected to ADC\_IN17 input channel of the ADC.

### 3.16 Debug mode

- Serial wire debug port

Debug capabilities can be accessed by a debug tool via Serial Wire (SW - Debug Port).

### 3.17 Package and operation temperature

- LQFP48 (GD32E235CxTx), LQFP32 (GD32E235KxTx), QFN32 (GD32E235KxUx), QFN28 (GD32E235GxUx), TSSOP20 (GD32E235FxPx) and LGA20 (GD32E235FvVx).
- Operation temperature range: -40°C to +85°C (industrial level) for grade 6 devices.

## 4 Electrical characteristics

### 4.1 Absolute maximum ratings

The maximum ratings are the limits to which the device can be subjected without permanently damaging the device. Note that the device is not guaranteed to operate properly at the maximum ratings. Exposure to the absolute maximum rating conditions for extended periods may affect device reliability.

**Table 4-1. Absolute maximum ratings<sup>(1)(4)</sup>**

Symbol	Parameter	Min	Max	Unit
$V_{DD}$	External voltage range <sup>(2)</sup>	$V_{SS} - 0.3$	$V_{SS} + 3.6$	V
$V_{DDA}$	External analog supply voltage	$V_{SSA} - 0.3$	$V_{SSA} + 3.6$	V
$V_{IN}$	Input voltage on 5V tolerant pin <sup>(3)</sup>	$V_{SS} - 0.3$	$V_{DD} + 3.6$	V
	Input voltage on other I/O	$V_{SS} - 0.3$	3.6	V
$ \Delta V_{DDx} $	Variations between different VDD power pins	—	50	mV
$ V_{SSx} - V_{SS} $	Variations between different ground pins	—	50	mV
$I_{IO}$	Maximum current for GPIO pins	—	$\pm 25$	mA
$T_A$	Operating temperature range	-40	+85	°C
$P_D$	Power dissipation at $T_A = 85^\circ\text{C}$ of LQFP48	—	574	mW
	Power dissipation at $T_A = 85^\circ\text{C}$ of LQFP32	—	724	
	Power dissipation at $T_A = 85^\circ\text{C}$ of QFN32	—	939	
	Power dissipation at $T_A = 85^\circ\text{C}$ of QFN28	—	845	
	Power dissipation at $T_A = 85^\circ\text{C}$ of TSSOP20	—	595	
	Power dissipation at $T_A = 85^\circ\text{C}$ of LGA20	—	416	
$T_{STG}$	Storage temperature range	-65	+150	°C
$T_J$	Maximum junction temperature	—	125	°C

(1) Guaranteed by design, not tested in production.

(2) All main power and ground pins should be connected to an external power source within the allowable range.

(3)  $V_{IN}$  maximum value cannot exceed 5.5 V.

(4) It is recommended that  $V_{DD}$  and  $V_{DDA}$  are powered by the same source. The maximum difference between  $V_{DD}$  and  $V_{DDA}$  does not exceed 300 mV during power-up and operation.

### 4.2 Operating conditions characteristics

**Table 4-2. DC operating conditions**

Symbol	Parameter	Conditions	Min <sup>(1)</sup>	Typ	Max <sup>(1)</sup>	Unit
$V_{DD}$	Supply voltage	—	1.8	3.3	3.6	V
$V_{DDA}$	Analog supply voltage	—	1.8	3.3	3.6	V

(1) Based on characterization, not tested in production.

**Figure 4-1. Recommended power supply decoupling capacitors<sup>(1)(2)</sup>**

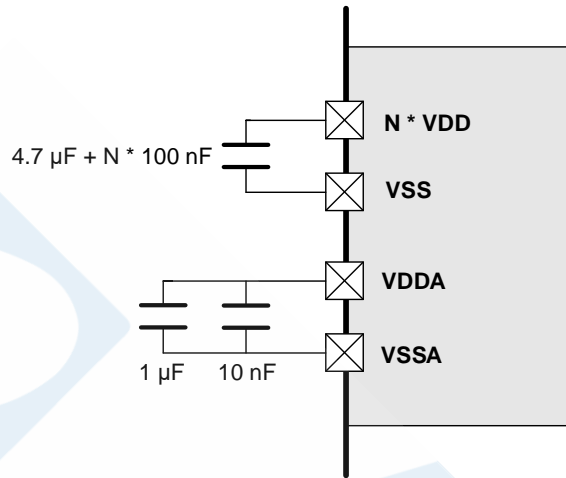

- (1) More details refer to **AN074 GD32E23x Hardware Development Guide**.
- (2) All decoupling capacitors need to be as close as possible to the pins on the PCB board.

**Table 4-3. Clock frequency<sup>(1)</sup>**

Symbol	Parameter	Conditions	Min	Max	Unit
f <sub>HCLK1</sub>	AHB1 clock frequency	—	0	72	MHz
f <sub>HCLK2</sub>	AHB2 clock frequency	—	0	72	MHz
f <sub>APB1</sub>	APB1 clock frequency	—	0	72	MHz
f <sub>APB2</sub>	APB2 clock frequency	—	0	72	MHz

- (1) Guaranteed by design, not tested in production.

**Table 4-4. Operating conditions at Power up/ Power down<sup>(1)</sup>**

Symbol	Parameter	Conditions	Min	Max	Unit
t <sub>VDD</sub>	V <sub>DD</sub> rise time rate	—	0	∞	μs/V
	V <sub>DD</sub> fall time rate		20	∞	

- (1) Guaranteed by design, not tested in production.

**Table 4-5. Start-up timings of Operating conditions<sup>(1)(2)(3)</sup>**

Symbol	Parameter	Conditions	Typ	Unit
t <sub>start-up</sub>	Start-up time	Clock source from HXTAL	850 <sup>(4)</sup>	μs
		Clock source from IRC8M	87	

- (1) Based on characterization, not tested in production.
- (2) After power-up, the start-up time is the time between the rising edge of NRST high and the first I/O instruction conversion in SystemInit function.
- (3) PLL is off.
- (4) When Clock source from HXTAL, the t<sub>start-up</sub> is related to the PCB layout and the quality of oscillator.

**Table 4-6. Power saving mode wakeup timings characteristics<sup>(1)(2)</sup>**

Symbol	Parameter	Typ	Unit
t <sub>Sleep</sub>	Wakeup from Sleep mode	2.5	μs
t <sub>Deep-sleep</sub>	Wakeup from Deep-sleep mode (LDO On)	31.6	
	Wakeup from Deep-sleep mode (LDO in low power mode)	31.6	
t <sub>Standby</sub>	Wakeup from Standby mode	87.4	

- (1) Based on characterization, not tested in production.  
 (2) The wakeup time is measured from the wakeup event to the point at which the application code reads the first instruction under the below conditions:  $V_{DD} = V_{DDA} = 3.3\text{ V}$ , IRC8M = System clock = 8 MHz.

### 4.3 Power consumption

The power measurements specified in the tables represent that code with data executing from on-chip Flash with the following specifications.

**Table 4-7. Power consumption characteristics<sup>(2)(3)(4)(5)</sup>**

Symbol	Parameter	Conditions	Min	Typ <sup>(1)</sup>	Max	Unit
I <sub>DD</sub> +I <sub>DDA</sub>	Supply current (Run mode)	V <sub>DD</sub> = V <sub>DDA</sub> = 3.3 V, HXTAL = 8 MHz, System clock = 72 MHz, All peripherals enabled	—	8.4	—	mA
		V <sub>DD</sub> = V <sub>DDA</sub> = 3.3 V, HXTAL = 8 MHz, System clock = 72 MHz, All peripherals disabled	—	5.4	—	mA
		V <sub>DD</sub> = V <sub>DDA</sub> = 3.3 V, HXTAL = 8 MHz, System clock = 48 MHz, All peripherals enabled	—	6.0	—	mA
		V <sub>DD</sub> = V <sub>DDA</sub> = 3.3 V, HXTAL = 8 MHz, System clock = 48 MHz, All peripherals disabled	—	4.1	—	mA
		V <sub>DD</sub> = V <sub>DDA</sub> = 3.3 V, HXTAL = 8 MHz, System clock = 36 MHz, All peripherals enabled	—	4.9	—	mA
		V <sub>DD</sub> = V <sub>DDA</sub> = 3.3 V, HXTAL = 8 MHz, System clock = 36 MHz, All peripherals disabled	—	3.4	—	mA
		V <sub>DD</sub> = V <sub>DDA</sub> = 3.3 V, HXTAL = 8 MHz, System clock = 24 MHz, All peripherals enabled	—	3.7	—	mA
		V <sub>DD</sub> = V <sub>DDA</sub> = 3.3 V, HXTAL = 8 MHz, System clock = 24 MHz, All peripherals disabled	—	2.7	—	mA
		V <sub>DD</sub> = V <sub>DDA</sub> = 3.3 V, HXTAL = 8 MHz, System clock = 16 MHz, All peripherals enabled	—	2.9	—	mA
		V <sub>DD</sub> = V <sub>DDA</sub> = 3.3 V, HXTAL = 8 MHz, System clock = 16 MHz, All peripherals disabled	—	2.3	—	mA
		V <sub>DD</sub> = V <sub>DDA</sub> = 3.3 V, HXTAL = 8 MHz, System clock = 8 MHz, All peripherals enabled	—	2.1	—	mA

Symbol	Parameter	Conditions	Min	Typ <sup>(1)</sup>	Max	Unit
		V <sub>DD</sub> = V <sub>DDA</sub> = 3.3 V, HXTAL = 8 MHz, System clock = 8 MHz, All peripherals disabled	—	1.7	—	mA
		V <sub>DD</sub> = V <sub>DDA</sub> = 3.3 V, HXTAL = 4 MHz, System clock = 4 MHz, All peripherals enabled	—	0.5	—	mA
		V <sub>DD</sub> = V <sub>DDA</sub> = 3.3 V, HXTAL = 4 MHz, System clock = 4 MHz, All peripherals disabled	—	0.4	—	mA
		V <sub>DD</sub> = V <sub>DDA</sub> = 3.3 V, HXTAL = 2 MHz, System clock = 2 MHz, All peripherals enabled	—	0.4	—	mA
		V <sub>DD</sub> = V <sub>DDA</sub> = 3.3 V, HXTAL = 2 MHz, System clock = 2 MHz, All peripherals disabled	—	0.3	—	mA
	Supply current (Sleep mode)	V <sub>DD</sub> = V <sub>DDA</sub> = 3.3 V, HXTAL = 8 MHz, CPU clock off, System clock = 72 MHz, All peripherals enabled	—	7.5	—	mA
		V <sub>DD</sub> = V <sub>DDA</sub> = 3.3 V, HXTAL = 8 MHz, CPU clock off, System clock = 72 MHz, All peripherals disabled	—	3.8	—	mA
		V <sub>DD</sub> = V <sub>DDA</sub> = 3.3 V, HXTAL = 8 MHz, CPU clock off, System clock = 48 MHz, All peripherals enabled	—	5.5	—	mA
		V <sub>DD</sub> = V <sub>DDA</sub> = 3.3 V, HXTAL = 8 MHz, CPU clock off, System clock = 48 MHz, All peripherals disabled	—	3.0	—	mA
		V <sub>DD</sub> = V <sub>DDA</sub> = 3.3 V, HXTAL = 8 MHz, CPU clock off, System clock = 36 MHz, All peripherals enabled	—	4.4	—	mA
		V <sub>DD</sub> = V <sub>DDA</sub> = 3.3 V, HXTAL = 8 MHz, CPU clock off, System clock = 36 MHz, All peripherals disabled	—	2.6	—	mA
		V <sub>DD</sub> = V <sub>DDA</sub> = 3.3 V, HXTAL = 8 MHz, CPU clock off, System clock = 24 MHz, All peripherals enabled	—	3.4	—	mA
		V <sub>DD</sub> = V <sub>DDA</sub> = 3.3 V, HXTAL = 8 MHz, CPU clock off, System clock = 24 MHz, All peripherals disabled	—	2.2	—	mA
		V <sub>DD</sub> = V <sub>DDA</sub> = 3.3 V, HXTAL = 8 MHz, CPU clock off, System clock = 16 MHz, All peripherals enabled	—	2.8	—	mA

Symbol	Parameter	Conditions	Min	Typ <sup>(1)</sup>	Max	Unit	
		$V_{DD} = V_{DDA} = 3.3\text{ V}$ , HXTAL = 8 MHz, CPU clock off, System clock = 16 MHz, All peripherals disabled	—	1.9	—	mA	
		$V_{DD} = V_{DDA} = 3.3\text{ V}$ , HXTAL = 8 MHz, CPU clock off, System clock = 8 MHz, All peripherals enabled	—	2.0	—	mA	
		$V_{DD} = V_{DDA} = 3.3\text{ V}$ , HXTAL = 8 MHz, CPU clock off, System clock = 8 MHz, All peripherals disabled	—	1.5	—	mA	
		$V_{DD} = V_{DDA} = 3.3\text{ V}$ , HXTAL = 4 MHz, CPU clock off, System clock = 4 MHz, All peripherals enabled	—	0.5	—	mA	
		$V_{DD} = V_{DDA} = 3.3\text{ V}$ , HXTAL = 4 MHz, CPU clock off, System clock = 4 MHz, All peripherals disabled	—	0.3	—	mA	
		$V_{DD} = V_{DDA} = 3.3\text{ V}$ , HXTAL = 2 MHz, CPU clock off, System clock = 2 MHz, All peripherals enabled	—	0.3	—	mA	
		$V_{DD} = V_{DDA} = 3.3\text{ V}$ , HXTAL = 2 MHz, CPU clock off, System clock = 2 MHz, All peripherals disabled	—	0.3	—	mA	
	Supply current (Deep-sleep mode)	$V_{DD} = V_{DDA} = 3.3\text{ V}$ , LDO in normal power and normal driver mode, IRC40K off, RTC off	—	32.3	—	$\mu\text{A}$	
		$V_{DD} = V_{DDA} = 3.3\text{ V}$ , LDO in normal power and low driver mode, IRC40K off, RTC off	—	20.4	66	$\mu\text{A}$	
	Supply current (Standby mode)	$V_{DD} = V_{DDA} = 3.3\text{ V}$ , LXTAL off, IRC40K on, RTC on	—	4.7	—	$\mu\text{A}$	
		$V_{DD} = V_{DDA} = 3.3\text{ V}$ , LXTAL off, IRC40K on, RTC off	—	4.5	—	$\mu\text{A}$	
		$V_{DD} = V_{DDA} = 3.3\text{ V}$ , LXTAL off, IRC40K off, RTC off, VDDA Monitor on	—	4.0	11	$\mu\text{A}$	
		$V_{DD} = V_{DDA} = 3.3\text{ V}$ , LXTAL off, IRC40K off, RTC off, VDDA Monitor off	—	2.5	—	$\mu\text{A}$	
	$I_{LXTAL+RTC}$	LXTAL+RTC current	$V_{DD} = V_{DDA} = 3.6\text{ V}$ , LXTAL on with external crystal, RTC on, Higher driving	—	1.53	—	$\mu\text{A}$
			$V_{DD} = V_{DDA} = 3.3\text{ V}$ , LXTAL on with external crystal, RTC on, Higher driving	—	1.44	—	$\mu\text{A}$
$V_{DD} = V_{DDA} = 2.5\text{ V}$ , LXTAL on with external crystal, RTC on, Higher driving			—	1.28	—	$\mu\text{A}$	
$V_{DD} = V_{DDA} = 1.8\text{ V}$ , LXTAL on with external crystal, RTC on, Higher driving			—	1.17	—	$\mu\text{A}$	
$V_{DD} = V_{DDA} = 3.6\text{ V}$ , LXTAL on with external crystal, RTC on, Medium High driving			—	1.24	—	$\mu\text{A}$	

Symbol	Parameter	Conditions	Min	Typ <sup>(1)</sup>	Max	Unit
		$V_{DD} = V_{DDA} = 3.3\text{ V}$ , LXTAL on with external crystal, RTC on, Medium High driving	—	1.14	—	$\mu\text{A}$
		$V_{DD} = V_{DDA} = 2.5\text{ V}$ , LXTAL on with external crystal, RTC on, Medium High driving	—	0.98	—	$\mu\text{A}$
		$V_{DD} = V_{DDA} = 1.8\text{ V}$ , LXTAL on with external crystal, RTC on, Medium High driving	—	0.88	—	$\mu\text{A}$
		$V_{DD} = V_{DDA} = 3.6\text{ V}$ , LXTAL on with external crystal, RTC on, Medium Low driving	—	0.95	—	$\mu\text{A}$
		$V_{DD} = V_{DDA} = 3.3\text{ V}$ , LXTAL on with external crystal, RTC on, Medium Low driving	—	0.85	—	$\mu\text{A}$
		$V_{DD} = V_{DDA} = 2.5\text{ V}$ , LXTAL on with external crystal, RTC on, Medium Low driving	—	0.69	—	$\mu\text{A}$
		$V_{DD} = V_{DDA} = 1.8\text{ V}$ , LXTAL on with external crystal, RTC on, Medium Low driving	—	0.60	—	$\mu\text{A}$
		$V_{DD} = V_{DDA} = 3.6\text{ V}$ , LXTAL on with external crystal, RTC on, Low driving	—	0.86	—	$\mu\text{A}$
		$V_{DD} = V_{DDA} = 3.3\text{ V}$ , LXTAL on with external crystal, RTC on, Low driving	—	0.76	—	$\mu\text{A}$
		$V_{DD} = V_{DDA} = 2.5\text{ V}$ , LXTAL on with external crystal, RTC on, Low driving	—	0.59	—	$\mu\text{A}$
		$V_{DD} = V_{DDA} = 1.8\text{ V}$ , LXTAL on with external crystal, RTC on, Low driving	—	0.50	—	$\mu\text{A}$

- (1) Based on characterization, not tested in production.
- (2) When System Clock is less than 4 MHz, an external source is used, and the HXTAL bypass function is needed, no PLL.
- (3) When System Clock is greater than 8 MHz, a crystal 8 MHz is used, and the HXTAL bypass function is closed, using PLL.
- (4) When analog peripheral blocks such as ADCs, HXTAL, LXTAL, IRC8M, or IRC40K are ON, an additional power consumption should be considered.
- (5) All GPIOs are configured as analog mode except standby mode.



Figure 4-2. Typical supply current consumption in Run mode

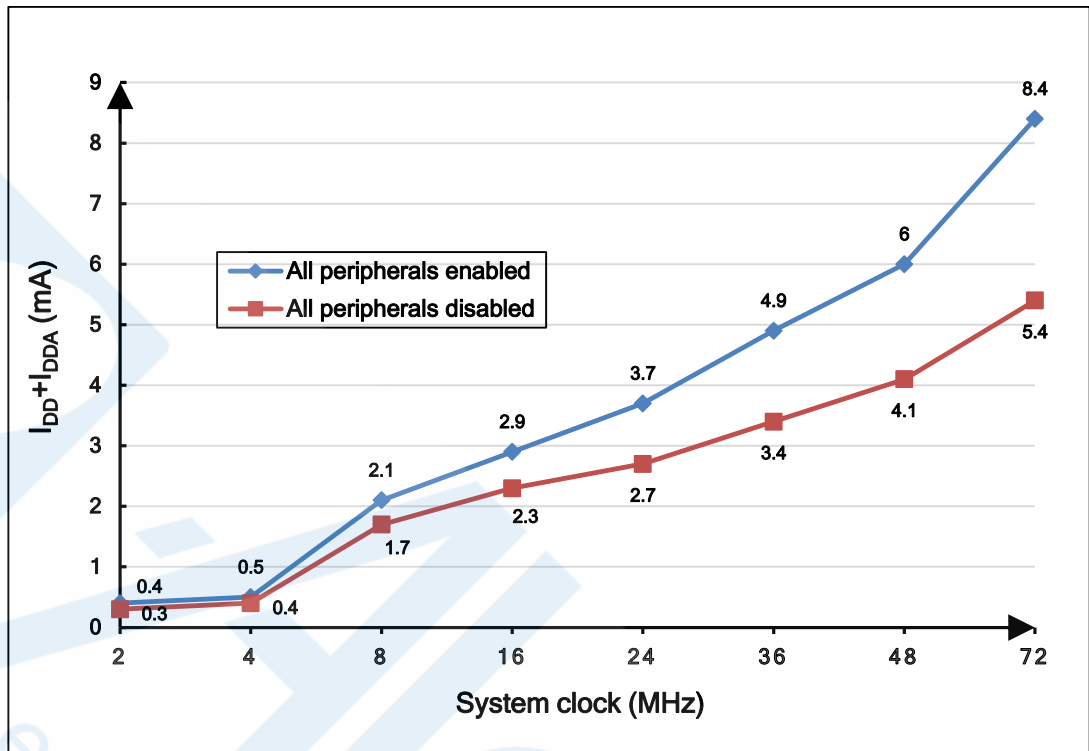
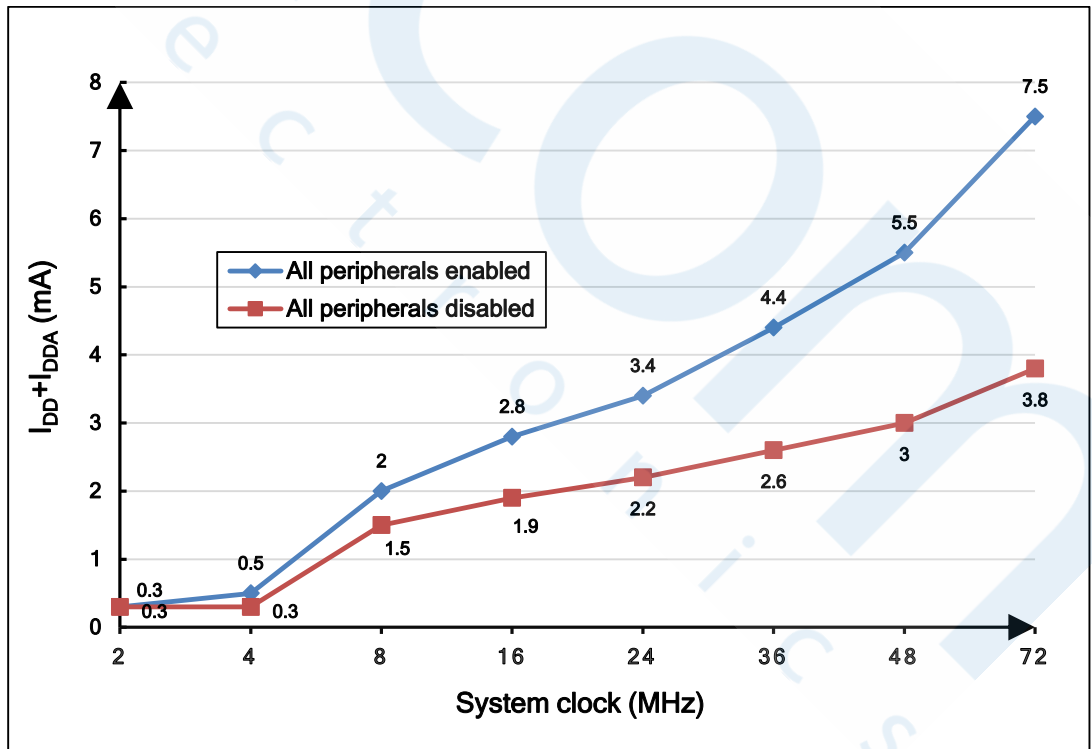

Figure 4-3. Typical supply current consumption in Sleep mode



## 4.4 EMC characteristics

System level ESD (Electrostatic discharge, according to IEC 61000-4-2) and EFT (Electrical Fast Transient/burst, according to IEC 61000-4-4) testing result is given in the [Table 4-8. System level ESD and EFT characteristics<sup>\(1\)</sup>](#). System level ESD is for end-customer operation, it includes ESD field events on system level occur in an unprotected area (outside EPA). System level ESD protection necessary to satisfy higher ESD levels.

**Table 4-8. System level ESD and EFT characteristics<sup>(1)</sup>**

Symbol	Parameter	Conditions	Package	Class	Level
V <sub>ESD</sub>	Contact / Air mode high voltage stressed on few special I/O pins	V <sub>DD</sub> = 3.3 V, T <sub>A</sub> = 25 °C, f <sub>HCLK</sub> = 72 MHz conforms to IEC 61000-4-2	LQFP48	CD 6kV AD 8kV	3A
V <sub>EFT</sub>	Fast transient high voltage burst stressed on Power and GND	V <sub>DD</sub> = 3.3 V, T <sub>A</sub> = 25 °C, f <sub>HCLK</sub> = 72 MHz conforms to IEC 61000-4-4	LQFP48	2kV	3A

(1) Based on characterization, not tested in production.

EMI (Electromagnetic Interference) emission test result is given in the [Table 4-9. EMI characteristics<sup>\(1\)</sup>](#). The electromagnetic field emitted by the device are monitored while an application, executing EEMBC code, is running. The test is compliant with SAE J1752-3:2017 standard which specifies the test board and the pin loading.

**Table 4-9. EMI characteristics<sup>(1)</sup>**

Symbol	Parameter	Conditions	Tested frequency band	Max vs. [f <sub>HXTAL</sub> /f <sub>HCLK</sub> ]	Unit
				8/72 MHz	
S <sub>EMI</sub>	Peak level	V <sub>DD</sub> = 3.6 V, T <sub>A</sub> = +25 °C, LQFP48, f <sub>HCLK</sub> = 72 MHz, conforms to SAE J1752-3:2017	0.15 MHz to 30 MHz	-1.59	dBμV
			30 MHz to 130 MHz	4.55	
			130 MHz to 1 GHz	8.02	

(1) Based on characterization, not tested in production.

Component level ESD include HBM (Human body model, according to ANSI/ESDA/JEDEC JS-001) and CDM (ANSI/ESDA/JEDEC JS-002), that ESD field events during manufacturing in an ESD protected area, such as PCB assembly/repair, IC assembly/test and Fab environment. The ESD protected area (EPA) has many measures, for instance ESD protective packaging, grounding person wrist strap to ground (or flooring/footwear), grounded work surface and ionizer.

Static latch-up (LU, according to JEDEC78) test is based on the two measurement methods, I/O current injection value (I-test) and power supply over-voltage value.

**Table 4-10. Component level ESD and latch-up characteristics<sup>(1)</sup>**

Symbol	Description	Conditions	Package	Max	Unit	Level
V <sub>HBM</sub>	Human body model electrostatic discharge voltage (Any pin combination)	T <sub>A</sub> = 25 °C; JS-001-2017	LQFP48	2000	V	2
V <sub>CDM</sub>	Charge device model electrostatic discharge voltage (All pins)	T <sub>A</sub> = 25 °C; JS-002-2018	LQFP48	500	V	C2a
LU	I-test	T <sub>A</sub> = 125 °C, JESD78F	LQFP48	200	mA	Class II Level A
	V <sub>supply</sub> over voltage			5.4	V	

(1) Value guaranteed by characterization, not 100% tested in production.

## 4.5 Power supply supervisor characteristics

**Table 4-11. Power supply supervisor characteristics<sup>(1)</sup>**

Symbol	Parameter	Conditions	Min	Typ	Max	Unit
V <sub>LVD</sub> <sup>(1)</sup>	Low Voltage Detector Threshold	LVDT[2:0] = 000, rising edge	—	2.11	—	V
		LVDT[2:0] = 000, falling edge	—	2.01	—	V
		LVDT[2:0] = 001, rising edge	—	2.25	—	V
		LVDT[2:0] = 001, falling edge	—	2.15	—	V
		LVDT[2:0] = 010, rising edge	—	2.39	—	V
		LVDT[2:0] = 010, falling edge	—	2.29	—	V
		LVDT[2:0] = 011, rising edge	—	2.53	—	V
		LVDT[2:0] = 011, falling edge	—	2.42	—	V
		LVDT[2:0] = 100, rising edge	—	2.66	—	V
		LVDT[2:0] = 100, falling edge	—	2.56	—	V
		LVDT[2:0] = 101, rising edge	—	2.80	—	V
		LVDT[2:0] = 101, falling edge	—	2.70	—	V
		LVDT[2:0] = 110, rising edge	—	2.94	—	V
		LVDT[2:0] = 110, falling edge	—	2.84	—	V
LVDT[2:0] = 111, rising edge	—	3.08	—	V		
LVDT[2:0] = 111, falling edge	—	2.98	—	V		
V <sub>LVDhyst</sub> <sup>(2)</sup>	LVD hysteresis	—	—	100	—	mV
V <sub>POR</sub> <sup>(1)</sup>	Power on reset threshold	—	—	1.68	—	V
V <sub>PDR</sub> <sup>(1)</sup>	Power down reset threshold		—	1.64	—	V
V <sub>PDRhyst</sub> <sup>(2)</sup>	PDR hysteresis		—	40	—	mV
t <sub>RSTTEMPO</sub> <sup>(2)</sup>	Reset temporization		—	2	—	ms

(1) Based on characterization, not tested in production.

(2) Guaranteed by design, not tested in production.

## 4.6 External clock characteristics

**Table 4-12. High speed external clock (HXTAL) generated from a crystal/ceramic characteristics**

Symbol	Parameter	Conditions	Min	Typ	Max	Unit
$f_{\text{HXTAL}}^{(1)}$	Crystal or ceramic frequency	$V_{\text{DD}} = 3.3 \text{ V}$	4	8	32	MHz
$R_{\text{F}}^{(2)}$	Feedback resistor	$V_{\text{DD}} = 3.3 \text{ V}$	—	400	—	k $\Omega$
$C_{\text{HXTAL}}^{(2)(3)}$	Recommended matching capacitance on OSCIN and OSCOUT	—	—	20	30	pF
$\text{Ducy}_{(\text{HXTAL})}^{(2)}$	Crystal or ceramic duty cycle	—	30	50	70	%
$g_{\text{m}}^{(2)}$	Oscillator transconductance	Startup	—	25	—	mA/V
$I_{\text{DD}(\text{HXTAL})}^{(1)}$	Crystal or ceramic operating current	$V_{\text{DD}} = 3.3 \text{ V}$	—	1.2	—	mA
$t_{\text{SUHXTAL}}^{(1)}$	Crystal or ceramic startup time	$V_{\text{DD}} = 3.3 \text{ V}$	—	1.8	—	ms

(1) Based on characterization, not tested in production.

(2) Guaranteed by design, not tested in production.

(3)  $C_{\text{HXTAL1}} = C_{\text{HXTAL2}} = 2 * (C_{\text{LOAD}} - C_{\text{S}})$ , For  $C_{\text{HXTAL1}}$  and  $C_{\text{HXTAL2}}$ , it is recommended matching capacitance on OSCIN and OSCOUT. For  $C_{\text{LOAD}}$ , it is crystal/ceramic load capacitance, provided by the crystal or ceramic manufacturer. For  $C_{\text{S}}$ , it is PCB and MCU pin stray capacitance.

**Table 4-13. High speed external user clock characteristics (HXTAL in bypass mode)**

Symbol	Parameter	Conditions	Min	Typ	Max	Unit
$f_{\text{HXTAL\_ext}}^{(1)}$	External clock source or oscillator frequency	$V_{\text{DD}} = 3.3 \text{ V}$	1	8	50	MHz
$V_{\text{HXTALH}}^{(2)}$	OSCIN input pin high level voltage	$V_{\text{DD}} = 3.3 \text{ V}$	$0.7 V_{\text{DD}}$	—	$V_{\text{DD}}$	V
$V_{\text{HXTALL}}^{(2)}$	OSCIN input pin low level voltage		$V_{\text{SS}}$	—	$0.3 V_{\text{DD}}$	
$t_{\text{H/L}(\text{HXTAL})}^{(2)}$	OSCIN high or low time	—	5	—	—	ns
$t_{\text{R/F}(\text{HXTAL})}^{(2)}$	OSCIN rise or fall time	—	—	—	10	
$C_{\text{IN}}^{(2)}$	OSCIN input capacitance	—	—	5	—	pF
$\text{Ducy}_{(\text{HXTAL})}^{(2)}$	Duty cycle	—	30	50	70	%

(1) Based on characterization, not tested in production.

(2) Guaranteed by design, not tested in production.

**Table 4-14. Low speed external clock (LXTAL) generated from a crystal/ceramic characteristics**

Symbol	Parameter	Conditions	Min	Typ	Max	Unit
$f_{LXTAL}^{(1)}$	Crystal or ceramic frequency	$V_{DD} = 3.3\text{ V}$	—	32.768	—	kHz
$C_{LXTAL}^{(2)(3)}$	Recommended matching capacitance on OSC32IN and OSC32OUT	—	—	10	—	pF
$D_{ucy(LXTAL)}^{(2)}$	Crystal or ceramic duty cycle	—	30	—	70	%
$g_m^{(2)}$	Oscillator transconductance	Lower driving capability	—	4	—	$\mu\text{A/V}$
		Medium low driving capability	—	6	—	
		Medium high driving capability	—	12	—	
		Higher driving capability	—	18	—	
$I_{DDLXTAL}^{(1)}$	Crystal or ceramic operating current	Lower driving capability	—	0.5	—	$\mu\text{A}$
		Medium low driving capability	—	0.6	—	
		Medium high driving capability	—	0.9	—	
		Higher driving capability	—	1.2	—	
$t_{SULXTAL}^{(2)(4)}$	Crystal or ceramic startup time	$V_{DD} = 3.3\text{ V}$	—	0.6	—	s

(1) Based on characterization, not tested in production.

(2) Guaranteed by design, not tested in production.

(3)  $C_{LXTAL1} = C_{LXTAL2} = 2 * (C_{LOAD} - C_S)$ , For  $C_{LXTAL1}$  and  $C_{LXTAL2}$ , it is recommended matching capacitance on OSC32IN and OSC32OUT. For  $C_{LOAD}$ , it is crystal/ceramic load capacitance, provided by the crystal or ceramic manufacturer. For  $C_S$ , it is PCB and MCU pin stray capacitance.

(4)  $t_{SULXTAL}$  is the startup time measured from the moment it is enabled (by software) to the 32.768 kHz oscillator stabilization flags is SET. This value varies significantly with the crystal manufacturer.

**Table 4-15. Low speed external user clock characteristics (LXTAL in bypass mode)**

Symbol	Parameter	Conditions	Min	Typ	Max	Unit
$f_{LXTAL\_ext}^{(1)}$	External clock source or oscillator frequency	$V_{DD} = 3.3\text{ V}$	—	32.768	1000	kHz
$V_{LXTALH}^{(2)}$	OSC32IN input pin high level voltage	$V_{DD} = 3.3\text{ V}$	0.7 $V_{DD}$	—	$V_{DD}$	V
$V_{LXTALL}^{(2)}$	OSC32IN input pin low level voltage		$V_{SS}$	—	0.3 $V_{DD}$	
$t_{H/L(LXTAL)}^{(2)}$	OSC32IN high or low time	—	450	—	—	ns
$t_{R/F(LXTAL)}^{(2)}$	OSC32IN rise or fall time	—	—	—	50	
$C_{IN}^{(2)}$	OSC32IN input capacitance	—	—	5	—	pF
$D_{ucy(LXTAL)}^{(2)}$	Duty cycle	—	30	50	70	%

- (1) Based on characterization, not tested in production.  
 (2) Guaranteed by design, not tested in production.

## 4.7 Internal clock characteristics

**Table 4-16. High speed internal clock (IRC8M) characteristics**

Symbol	Parameter	Conditions	Min	Typ	Max	Unit
$f_{IRC8M}$	High Speed Internal Oscillator (IRC8M) frequency	$V_{DD} = V_{DDA} = 3.3\text{ V}$	—	8	—	MHz
$ACC_{IRC8M}^{(1)}$	IRC8M oscillator Frequency accuracy, Factory-trimmed	$V_{DD} = V_{DDA} = 3.3\text{ V}$ , $T_A = -40\text{ }^\circ\text{C} \sim +85\text{ }^\circ\text{C}$	—	-0.6 to 0.3 <sup>(2)</sup>	—	%
		$V_{DD} = V_{DDA} = 3.3\text{ V}$ , $T_A = 25\text{ }^\circ\text{C}$	-1.0	—	+1.0	
	IRC8M oscillator Frequency accuracy, User trimming step	—	—	0.5	—	%
$D_{IRC8M}^{(2)}$	IRC8M oscillator duty cycle	$V_{DD} = V_{DDA} = 3.3\text{ V}$	45	50	55	%
$I_{DDIRC8M}^{(1)}$	IRC8M oscillator operating current	$V_{DD} = V_{DDA} = 3.3\text{ V}$ , $f_{IRC8M} = 8\text{ MHz}$	—	43	—	$\mu\text{A}$
$t_{SUIRC8M}^{(1)}$	IRC8M oscillator startup time	$V_{DD} = V_{DDA} = 3.3\text{ V}$ , $f_{IRC8M} = 8\text{ MHz}$	—	1.6	—	$\mu\text{s}$

- (1) Based on characterization, not tested in production.  
 (2) Guaranteed by design, not tested in production.

**Table 4-17. Low speed internal clock (IRC40K) characteristics**

Symbol	Parameter	Conditions	Min	Typ	Max	Unit
$f_{IRC40K}^{(1)}$	Low Speed Internal oscillator (IRC40K) frequency	$V_{DD} = V_{DDA} = 3.3\text{ V}$	—	40	—	kHz
$I_{DDIRC40K}^{(2)}$	IRC40K oscillator operating current	$V_{DD} = V_{DDA} = 3.3\text{ V}$	—	0.39	—	$\mu\text{A}$
$t_{SUIRC40K}^{(2)}$	IRC40K oscillator startup time	$V_{DD} = V_{DDA} = 3.3\text{ V}$	—	24	—	$\mu\text{s}$

- (1) Guaranteed by design, not tested in production.  
 (2) Based on characterization, not tested in production.

**Table 4-18. High speed internal clock (IRC28M) characteristics**

Symbol	Parameter	Conditions	Min	Typ	Max	Unit
$f_{IRC28M}$	High Speed Internal Oscillator (IRC28M) frequency	$V_{DD} = V_{DDA} = 3.3\text{ V}$	—	28	—	MHz
$ACC_{IRC28M}^{(1)}$	IRC28M oscillator Frequency accuracy, Factory-trimmed	$V_{DD} = V_{DDA} = 3.3\text{ V}$ , $T_A = -40\text{ }^\circ\text{C} \sim +85\text{ }^\circ\text{C}$	—	-0.2 to 0.04 <sup>(2)</sup>	—	%
		$V_{DD} = V_{DDA} = 3.3\text{ V}$ , $T_A = 25\text{ }^\circ\text{C}$	-2.0	—	+2.0	
	IRC28M oscillator Frequency accuracy, User trimming step	—	—	1	—	%
$D_{IRC28M}^{(2)}$	IRC28M oscillator duty cycle	$V_{DD} = V_{DDA} = 3.3\text{ V}$	45	50	55	%
$I_{DDAIRC28M}^{(1)}$	IRC28M oscillator operating current	$V_{DD} = V_{DDA} = 3.3\text{ V}$ , $f_{IRC28M} = 28\text{ MHz}$	—	110	—	$\mu\text{A}$
$t_{SUIRC28M}^{(1)}$	IRC28M oscillator startup time	$V_{DD} = V_{DDA} = 3.3\text{ V}$ , $f_{IRC28M} = 28\text{ MHz}$	—	1.5	—	$\mu\text{s}$

(1) Based on characterization, not tested in production.

(2) Guaranteed by design, not tested in production.

## 4.8 PLL characteristics

**Table 4-19. PLL characteristics**

Symbol	Parameter	Conditions	Min	Typ	Max	Unit
$f_{PLLIN}^{(1)}$	PLL input clock frequency	—	1	—	25	MHz
$f_{PLLOUT}^{(2)}$	PLL output clock frequency	—	16	—	72	MHz
$f_{VCO}^{(2)}$	PLL VCO output clock frequency	—	—	—	72	MHz
$t_{LOCK}^{(2)}$	PLL lock time	—	—	—	300	$\mu\text{s}$
$I_{DD}^{(1)}$	Current consumption on $V_{DD}$	VCO freq = 72 MHz	—	102	—	$\mu\text{A}$
$I_{DDA}^{(1)}$	Current consumption on $V_{DDA}$	VCO freq = 72 MHz	—	370	—	$\mu\text{A}$
Jitter <sub>PLL</sub> <sup>(3)</sup>	Cycle to cycle Jitter (rms)	System clock	—	159	—	ps

(1) Based on characterization, not tested in production.

(2) Guaranteed by design, not tested in production.

(3) Value given with main PLL running.

## 4.9 Memory characteristics

Table 4-20. Flash memory characteristics

Symbol	Parameter	Conditions	Min	Typ	Max	Unit
$PE_{CYC}^{(1)}$	Number of guaranteed program /erase cycles before failure (Endurance)	—	100	—	—	kcycles
$t_{RET}^{(1)}$	Data retention time	—	10	—	—	years
$t_{PROG}^{(2)}$	Word programming time	$T_A = -40\text{ }^\circ\text{C} \sim +85\text{ }^\circ\text{C}$	—	197	—	$\mu\text{s}$
$t_{ERASE}^{(2)}$	Page erase time		—	5	—	ms
$t_{MERASE}^{(2)}$	Mass erase time		—	35	—	ms

- (1) Based on characterization, not tested in production.  
 (2) Guaranteed by design, not tested in production.

## 4.10 NRST pin characteristics

Table 4-21. NRST pin characteristics

Symbol	Parameter	Conditions	Min	Typ	Max	Unit
$V_{L(NRST)}^{(1)}$	NRST Input low level voltage	$1.8\text{ V} \leq V_{DD} = V_{DDA} \leq 3.6\text{ V}$	-0.3	—	$0.35 V_{DD}$	V
$V_{IH(NRST)}^{(1)}$	NRST Input high level voltage		$0.65 V_{DD}$	—	$V_{DD} + 0.3$	
$V_{hyst}^{(1)}$	Schmidt trigger Voltage hysteresis		—	300	—	mV
$R_{pu}^{(2)}$	Pull-up equivalent resistor	—	—	40	—	$k\Omega$

- (1) Based on characterization, not tested in production.  
 (2) Guaranteed by design, not tested in production.

Figure 4-4. Recommended external NRST pin circuit

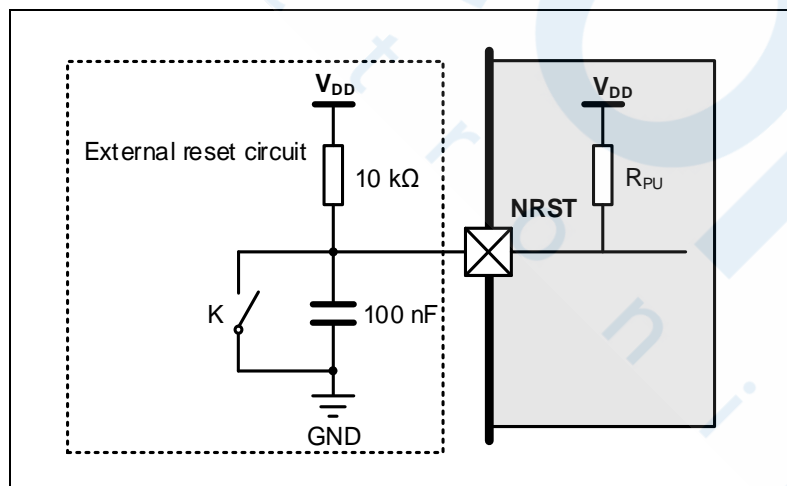

- (1) Unless the voltage on NRST pin go below  $V_{L(NRST)}$  level, the device would not generate a reliable reset.



## 4.11 GPIO characteristics

**Table 4-22. I/O port DC characteristics<sup>(1)(3)</sup>**

Symbol	Parameter	Conditions	Min	Typ	Max	Unit
V <sub>IL</sub>	Standard IO Low level input voltage	$1.8\text{ V} \leq V_{DD} = V_{DDA} \leq 3.6\text{ V}$	—	—	$0.3 V_{DD}$	V
	5V-tolerant IO Low level input voltage	$1.8\text{ V} \leq V_{DD} = V_{DDA} \leq 3.6\text{ V}$	—	—	$0.3 V_{DD}$	V
V <sub>IH</sub>	Standard IO High level input voltage	$1.8\text{ V} \leq V_{DD} = V_{DDA} \leq 3.6\text{ V}$	$0.7 V_{DD}$	—	—	V
	5 V-tolerant IO High level input voltage	$1.8\text{ V} \leq V_{DD} = V_{DDA} \leq 3.6\text{ V}$	$0.7 V_{DD}$	—	—	V
V <sub>OL</sub>	Low level output voltage for an IO Pin ( $I_{IO} = +8\text{ mA}$ )	$V_{DD} = 1.8\text{ V}$	—	0.25	—	V
		$V_{DD} = 2.5\text{ V}$	—	0.18	—	
		$V_{DD} = 3.3\text{ V}$	—	0.15	—	
		$V_{DD} = 3.6\text{ V}$	—	0.15	—	
V <sub>OL</sub>	Low level output voltage for an IO Pin ( $I_{IO} = +20\text{ mA}$ )	$V_{DD} = 1.8\text{ V}$	—	1.15	—	V
		$V_{DD} = 2.5\text{ V}$	—	0.47	—	
		$V_{DD} = 3.3\text{ V}$	—	0.40	—	
		$V_{DD} = 3.6\text{ V}$	—	0.38	—	
V <sub>OH</sub>	High level output voltage for an IO Pin ( $I_{IO} = +8\text{ mA}$ )	$V_{DD} = 1.8\text{ V}$	—	1.51	—	V
		$V_{DD} = 2.5\text{ V}$	—	2.29	—	
		$V_{DD} = 3.3\text{ V}$	—	3.13	—	
		$V_{DD} = 3.6\text{ V}$	—	3.46	—	
V <sub>OH</sub>	High level output voltage for an IO Pin ( $I_{IO} = +20\text{ mA}$ )	$V_{DD} = 1.8\text{ V}$	—	0.95	—	V
		$V_{DD} = 2.5\text{ V}$	—	1.92	—	
		$V_{DD} = 3.3\text{ V}$	—	2.83	—	
		$V_{DD} = 3.6\text{ V}$	—	3.18	—	
R <sub>PU</sub> <sup>(2)</sup>	Internal pull-up resistor	—	—	40	—	kΩ
R <sub>PD</sub> <sup>(2)</sup>	Internal pull-down resistor	—	—	40	—	kΩ

(1) Based on characterization, not tested in production.

(2) Guaranteed by design, not tested in production.

(3) All pins except PC13 / PC14 / PC15. Since PC13 to PC15 are supplied through the Power Switch, which can only be obtained by a small current( typical source capability:3 mA shared between these IOs, but sink capability is same as other IO. ), the speed of GPIOs PC13 to PC15 should not exceed 2 MHz when they are in output mode(maximum load: 30 pF).

**Table 4-23. I/O port AC characteristics<sup>(1)(2)</sup>**

GPIOx_OSPD[1:0] bit value <sup>(3)</sup>	Parameter	Conditions	Max	Unit
GPIOx_OSPD0->OSPDy[1:0] = X0 (IO_Speed = 2 MHz)	Maximum frequency <sup>(4)</sup>	$1.8 \leq V_{DD} \leq 3.6\text{ V}, C_L = 10\text{ pF}$	8	MHz
		$1.8 \leq V_{DD} \leq 3.6\text{ V}, C_L = 30\text{ pF}$	6	
		$1.8 \leq V_{DD} \leq 3.6\text{ V}, C_L = 50\text{ pF}$	6	
GPIOx_OSPD0->OSPDy[1:0] = 01 (IO_Speed = 10 MHz)	Maximum frequency <sup>(4)</sup>	$1.8 \leq V_{DD} \leq 3.6\text{ V}, C_L = 10\text{ pF}$	30	MHz
		$1.8 \leq V_{DD} \leq 3.6\text{ V}, C_L = 30\text{ pF}$	26	

GPIOx_OSPD[1:0] bit value <sup>(3)</sup>	Parameter	Conditions	Max	Unit
		$1.8 \leq V_{DD} \leq 3.6 \text{ V}, C_L = 50 \text{ pF}$	23	
GPIOx_OSPD0->OSPDy[1:0] = 11 (IO_Speed = 50 MHz)	Maximum frequency <sup>(4)</sup>	$1.8 \leq V_{DD} \leq 3.6 \text{ V}, C_L = 10 \text{ pF}$	72	MHz
		$1.8 \leq V_{DD} \leq 3.6 \text{ V}, C_L = 30 \text{ pF}$	72	
		$1.8 \leq V_{DD} \leq 3.6 \text{ V}, C_L = 50 \text{ pF}$	72	

- (1) Based on characterization, not tested in production.
- (2) Unless otherwise specified, all test results given for  $T_A = 25 \text{ }^\circ\text{C}$ .
- (3) The I/O speed is configured using the GPIOx\_OSPD0->OSPDy [1:0] bits. Refer to the GD32E23x user manual which is selected to set the GPIO port output speed.
- (4) The maximum frequency is defined in Figure 4-5, and maximum frequency cannot exceed 72 MHz.

**Figure 4-5. I/O port AC characteristics definition**

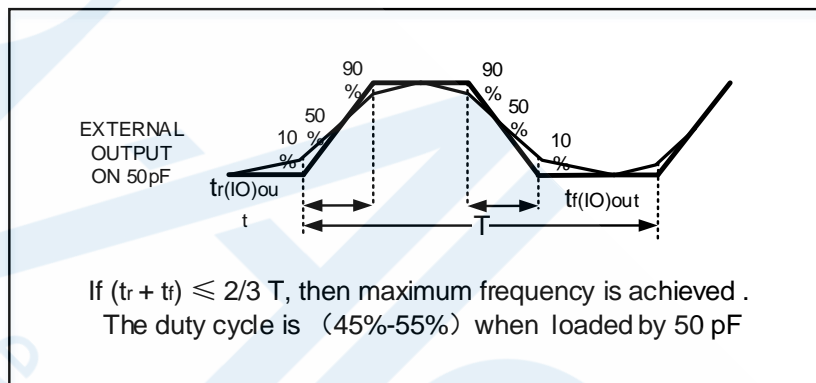

## 4.12 ADC characteristics

**Table 4-24. ADC characteristics**

Symbol	Parameter	Conditions	Min	Typ	Max	Unit
$V_{DDA}^{(1)}$	Operating voltage	—	1.8	3.3	3.6	V
$V_{IN}^{(1)}$	ADC input voltage range	—	0	—	$V_{DDA}$	V
$f_{ADC}^{(1)}$	ADC clock	—	0.1	—	28	MHz
$f_s^{(1)}$	Sampling rate	12-bit	0.007	—	2	MSP
		10-bit	0.008	—	2.3	
		8-bit	0.01	—	2.8	S
		6-bit	0.011	—	3.5	
$V_{AIN}^{(1)}$	Analog input voltage	10 external; 2 internal	0	—	$V_{DDA}$	V
$R_{AIN}^{(2)}$	External input impedance	See <a href="#">Equation 1</a>	—	—	127.24	k $\Omega$
$R_{ADC}^{(2)}$	Input sampling switch resistance	—	—	—	0.5	k $\Omega$
$C_{ADC}^{(2)}$	Input sampling capacitance	No pin/pad capacitance included	—	—	6.9	pF
$t_{CAL}^{(2)}$	Calibration time	$f_{ADC} = 28 \text{ MHz}$	—	4.68	—	$\mu\text{s}$
$t_s^{(2)}$	Sampling time	$f_{ADC} = 28 \text{ MHz}$	0.05	—	8.55	$\mu\text{s}$
$t_{CONV}^{(2)}$	Total conversion time(including sampling	12-bit	—	14	—	1/ $f_{ADC}$
		10-bit	—	12	—	

Symbol	Parameter	Conditions	Min	Typ	Max	Unit
	time)	8-bit	—	10	—	
		6-bit	—	8	—	
t <sub>SU</sub> <sup>(2)</sup>	Startup time	—	—	—	1	μs

(1) Based on characterization, not tested in production.

(2) Guaranteed by design, not tested in production.

**Equation 1:**  $R_{AIN\ max} \text{ formula } R_{AIN} < \frac{T_s}{f_{ADC} * C_{ADC} * \ln(2^{N+2})} - R_{ADC}$

The formula above (Equation 1) is used to determine the maximum external impedance allowed for an error below 1/4 of LSB. Here N = 12 (from 12-bit resolution).

**Table 4-25. Internal reference voltage calibration values**

Symbol	Test conditions	Memory address
V <sub>REFINT</sub> <sup>(1)</sup>	V <sub>DD</sub> = V <sub>DPA</sub> = V <sub>REFP</sub> = 3.3 V (± 2 mV), T <sub>A</sub> = 25 °C (± 5 °C)	0x1FFF F7C0 - 0x1FFF F7C1

(1) V<sub>REFINT</sub> is internally connected to the ADC\_IN17 input channel.

(2) Low bit data is placed at the low bit address, and high bit data is placed at the high bit address.

**Table 4-26. ADC R<sub>AIN</sub> max for f<sub>ADC</sub> = 28 MHz<sup>(1)(2)</sup>**

T <sub>s</sub> (cycles)	t <sub>s</sub> (μs)	R <sub>AIN</sub> max (kΩ)
1.5	0.05	0.30
7.5	0.27	3.50
13.5	0.48	6.70
28.5	1.02	14.70
41.5	1.48	21.60
55.5	1.98	29.10
71.5	2.55	37.60
239.5	8.55	127.24

(1) Based on characterization, not tested in production.

(2) The R<sub>AIN</sub> value was calculate by theory and stray capacitance of actual PCB has not been taken into account.

**Table 4-27. ADC dynamic accuracy at f<sub>ADC</sub> = 28 MHz<sup>(1)</sup>**

Symbol	Parameter	Test conditions	Min	Typ	Max	Unit
ENOB	Effective number of bits	f <sub>ADC</sub> = 28 MHz	—	10.8	—	bits
SNDR	Signal-to-noise and distortion ratio	V <sub>DPA</sub> = V <sub>REFP</sub> = 3.3 V Input Frequency = 20 kHz Temperature = 25°C	—	66.81	—	dB
SNR	Signal-to-noise ratio		—	66.88	—	
THD	Total harmonic distortion		—	-80	—	

(1) Based on characterization, not tested in production.

**Table 4-28. ADC static accuracy at f<sub>ADC</sub> = 28 MHz<sup>(1)</sup>**

Symbol	Parameter	Test conditions	Typ	Max	Unit
Offset	Offset error	f <sub>ADC</sub> = 28 MHz V <sub>DPA</sub> = V <sub>REFP</sub> = 3.3 V	±1	—	LSB
DNL	Differential linearity error		±1	—	
INL	Integral linearity error		±1.5	—	

(1) Based on characterization, not tested in production.

## 4.13 Temperature sensor characteristics

**Table 4-29. Temperature sensor characteristics**

Symbol	Parameter	Min	Typ	Max	Unit
$T_L^{(1)}$	VSENSE linearity with temperature	—	$\pm 1.5$	—	$^{\circ}\text{C}$
Avg_Slope <sup>(1)</sup>	Average slope	—	4.33	—	mV/ $^{\circ}\text{C}$
$V_{25}^{(1)}$	Voltage at 25 $^{\circ}\text{C}$	—	1.44	—	V
$t_{S\_temp}^{(2)}$	ADC sampling time when reading the temperature	—	17.1	—	$\mu\text{s}$

(1) Based on characterization, not tested in production.

(2) Shortest sampling time can be determined in the application by multiple iterations.

**Table 4-30. Temperature sensor calibration values**

Symbol	Parameter	Memory address
TS_CAL	Temperature sensor raw data acquired value at 25 $^{\circ}\text{C}$ ( $\pm 5$ $^{\circ}\text{C}$ ), $V_{DD} = V_{DDA} = V_{REFP} = 3.3\text{V}$ ( $\pm 2$ mV)	0x1FFF F7C4 - 0x1FFF F7C5

(1) Low bit data is placed at the low bit address, and high bit data is placed at the high bit address.

## 4.14 Comparators characteristics

**Table 4-31. CMP characteristics<sup>(1)</sup>**

Symbol	Parameter	Conditions	Min	Typ	Max	Unit
$V_{DDA}$	Operating voltage	—	1.8	3.3	3.6	V
$V_{IN}$	Input voltage range	—	0	—	$V_{DDA}$	V
$V_{BG}$	Scaler input voltage	—	—	1.2	—	V
$V_{Sc}$	Scaler offset voltage	—	—	—	—	mV
$t_D$	Propagation delay for 200 mV step with 100 mV overdrive	Ultra low power mode	—	383	—	ns
		Low power mode	—	214	—	ns
		Medium power mode	—	89	—	ns
		High speed power mode	—	28	—	ns
	Propagation delay for full range step with 100 mV overdrive	Ultra low power mode	—	614	—	ns
		Low power mode	—	343	—	ns
		Medium power mode	—	133	—	ns
		High speed power mode	—	37	—	ns
$I_{DD}$	Current consumption	Ultra low power mode	—	1.7	—	$\mu\text{A}$
		Low power mode	—	2.8	—	
		Medium power mode	—	7.9	—	
		High speed power mode	—	48.9	—	
$V_{offset}$	Offset error	—	—	$\pm 4$	—	mV
$V_{hyst}$	Hysteresis Voltage	No Hysteresis	—	0	—	mV
		Low Hysteresis	—	13	—	
		Medium Hysteresis	—	28	—	

(1) Based on characterization, not tested in production.

Figure 4-6. CMP hysteresis

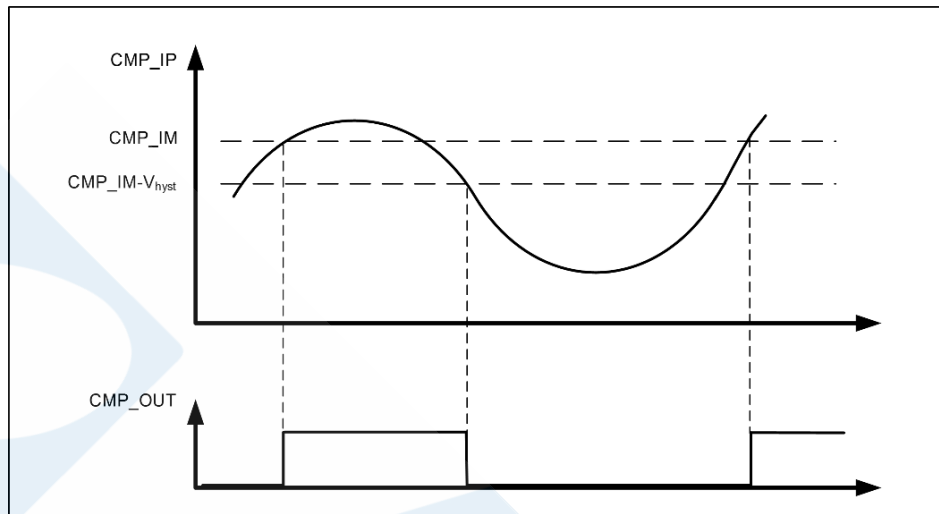

## 4.15 TIMER characteristics

Table 4-32. TIMER characteristics<sup>(1)</sup>

Symbol	Parameter	Conditions	Min	Max	Unit
t <sub>res</sub>	Timer resolution time	—	1	—	t <sub>TIMERxCLK</sub>
		f <sub>TIMERxCLK</sub> = 72 MHz	13.9	—	ns
f <sub>EXT</sub>	Timer external clock frequency	—	0	f <sub>TIMERxCLK</sub> /2	MHz
		f <sub>TIMERxCLK</sub> = 72 MHz	0	36	MHz
RES	Timer resolution	—	—	16	bit
t <sub>COUNTER</sub>	16-bit counter clock period when internal clock is selected	—	1	65536	t <sub>TIMERxCLK</sub>
		f <sub>TIMERxCLK</sub> = 72 MHz	0.0139	910	μs
t <sub>MAX_COUNT</sub>	Maximum possible count	—	—	65536 × 65536	t <sub>TIMERxCLK</sub>
		f <sub>TIMERxCLK</sub> = 72 MHz	—	59.6	s

(1) Guaranteed by design, not tested in production.

## 4.16 I2C characteristics

Table 4-33. I2C characteristics<sup>(1)(2)</sup>

Symbol	Parameter	Condi tions	Standard mode		Fast mode		Fast mode plus		Unit
			Min	Max	Min	Max	Min	Max	
$t_{SCL(H)}$	SCL clock high time	—	4.0	—	0.6	—	0.2	—	$\mu s$
$t_{SCL(L)}$	SCL clock low time	—	4.7	—	1.3	—	0.5	—	$\mu s$
$t_{SU(SDA)}$	SDA setup time	—	250	—	100	—	50	—	ns
$t_{H(SDA)}$	SDA data hold time	—	0 <sup>(3)</sup>	3450	0	900	0	450	ns
$t_{R(SDA/SCL)}$	SDA and SCL rise time	—	—	1000	—	300	—	120	ns
$t_{F(SDA/SCL)}$	SDA and SCL fall time	—	—	300	—	300	—	120	ns
$t_{H(STA)}$	Start condition hold time	—	4.0	—	0.6	—	0.26	—	$\mu s$
$t_{SU(STA)}$	Repeated Start condition setup time	—	4.7	—	0.6	—	0.26	—	$\mu s$
$t_{SU(STO)}$	Stop condition setup time	—	4.0	—	0.6	—	0.26	—	$\mu s$
$t_{BUFF}$	Stop to Start condition time (bus free)	—	4.7	—	1.3	—	0.5	—	$\mu s$

- (1) Guaranteed by design, not tested in production.
- (2) To ensure the standard mode I2C frequency,  $f_{PCLK1}$  must be at least 2 MHz, To ensure the fast mode I2C frequency,  $f_{PCLK1}$  must be at least 4 MHz. To ensure the fast mode plus I2C frequency,  $f_{PCLK1}$  must be at least a multiple of 10 MHz.
- (3) The device should provide a data hold time of 300 ns at least in order to bridge the undefined region of the falling edge of SCL.

Figure 4-7. I2C bus timing diagram

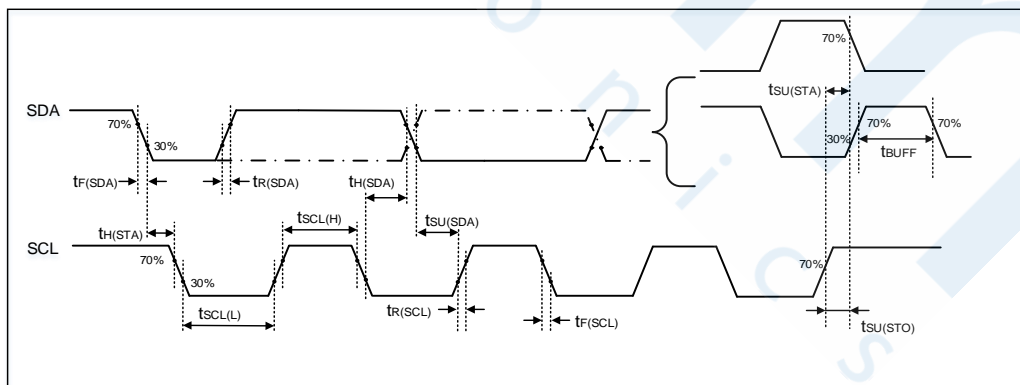

### 4.17 SPI characteristics

Table 4-34. Standard SPI characteristics<sup>(1)</sup>

Symbol	Parameter	Conditions	Min	Typ	Max	Unit
$f_{SCK}$	SCK clock frequency	—	—	—	18	MHz
$t_{SCK(H)}$	SCK clock high time	Master mode, $f_{PCLKx} = 72$ MHz, presc = 4	25	27	29	ns
$t_{SCK(L)}$	SCK clock low time	Master mode, $f_{PCLKx} = 72$ MHz, presc = 4	25	27	29	ns
<b>SPI master mode</b>						
$t_{V(MO)}$	Data output valid time	—	—	—	2	ns
$t_{SU(MI)}$	Data input setup time	—	5	—	—	ns
$t_{H(MI)}$	Data input hold time	—	5	—	—	ns
<b>SPI slave mode</b>						
$t_{SU(NSS)}$	NSS enable setup time	—	0	—	—	ns
$t_{H(NSS)}$	NSS enable hold time	—	1	—	—	ns
$t_{A(SO)}$	Data output access time	—	—	7	—	ns
$t_{DIS(SO)}$	Data output disable time	—	—	8	—	ns
$t_{V(SO)}$	Data output valid time	—	—	10	—	ns
$t_{SU(SI)}$	Data input setup time	—	—	10	—	ns
$t_{H(SI)}$	Data input hold time	—	0	—	—	ns

(1) Based on characterization, not tested in production.

Figure 4-8. SPI timing diagram - master mode

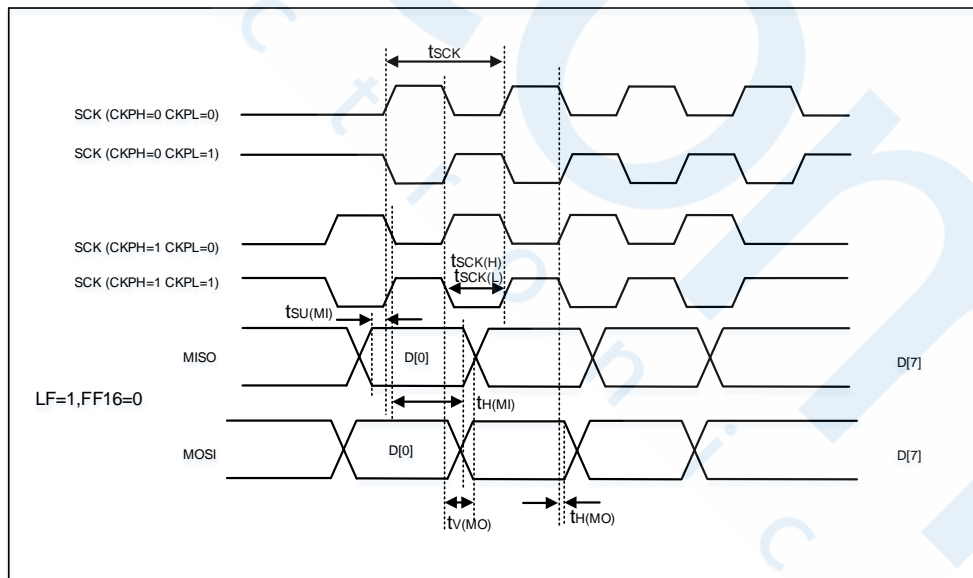
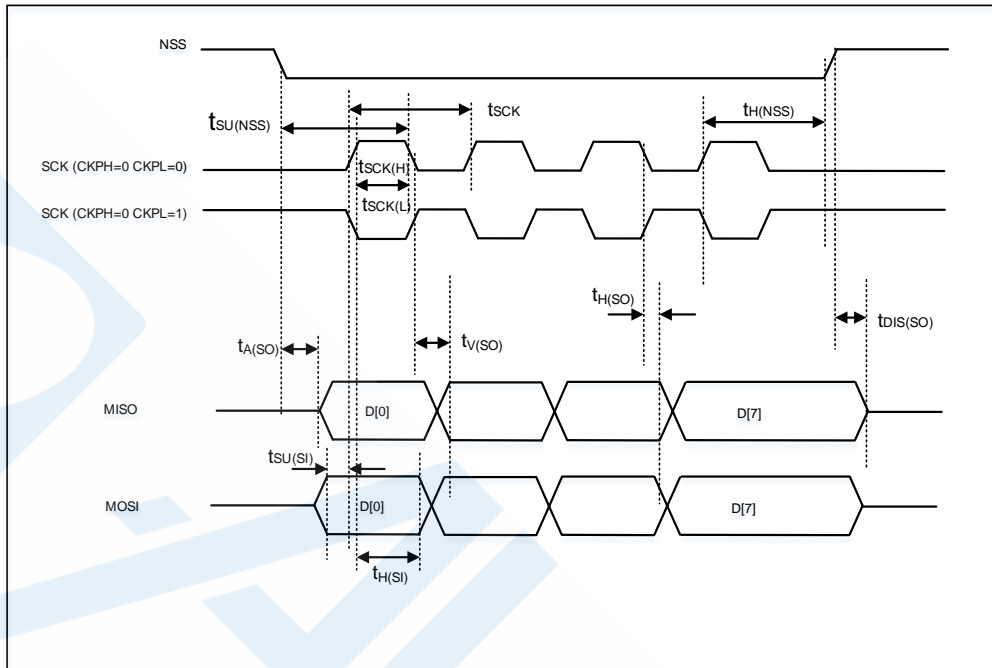

Figure 4-9. SPI timing diagram - slave mode





## 4.18 I2S characteristics

**Table 4-35. I2S characteristics<sup>(1)</sup>**

Symbol	Parameter	Conditions	Min	Typ	Max	Unit
$f_{CK}$	Clock frequency	Master mode (data: 16 bits, Audio frequency = 96 kHz)	—	3.12	—	MHz
		Slave mode	—	10	—	
$t_H$	Clock high time	—	—	160	—	ns
$t_L$	Clock low time		—	160	—	ns
$t_{V(WS)}$	WS valid time	Master mode	—	3	—	ns
$t_{H(WS)}$	WS hold time	Master mode	—	3	—	ns
$t_{SU(WS)}$	WS setup time	Slave mode	0	—	—	ns
$t_{H(WS)}$	WS hold time	Slave mode	3	—	—	ns
$D_{UCY(sck)}$	I2S slave input clock duty cycle	Slave mode	—	50	—	%
$t_{SU(SD\_MR)}$	Data input setup time	Master mode	0	—	—	ns
$t_{SU(SD\_SR)}$	Data input setup time	Slave mode	0	—	—	ns
$t_{H(SD\_MR)}$	Data input hold time	Master receiver	2	—	—	ns
$t_{H(SD\_SR)}$		Slave receiver	2	—	—	ns
$t_{V(SD\_ST)}$	Data output valid time	Slave transmitter (after enable edge)	—	12	—	ns
$t_{H(SD\_ST)}$	Data output hold time	Slave transmitter (after enable edge)	—	10	—	ns
$t_{V(SD\_MT)}$	Data output valid time	Master transmitter (after enable edge)	—	10	—	ns
$t_{H(SD\_MT)}$	Data output hold time	Master transmitter (after enable edge)	—	7	—	ns

(1) Based on characterization, not tested in production.

Figure 4-10. I2S timing diagram - master mode

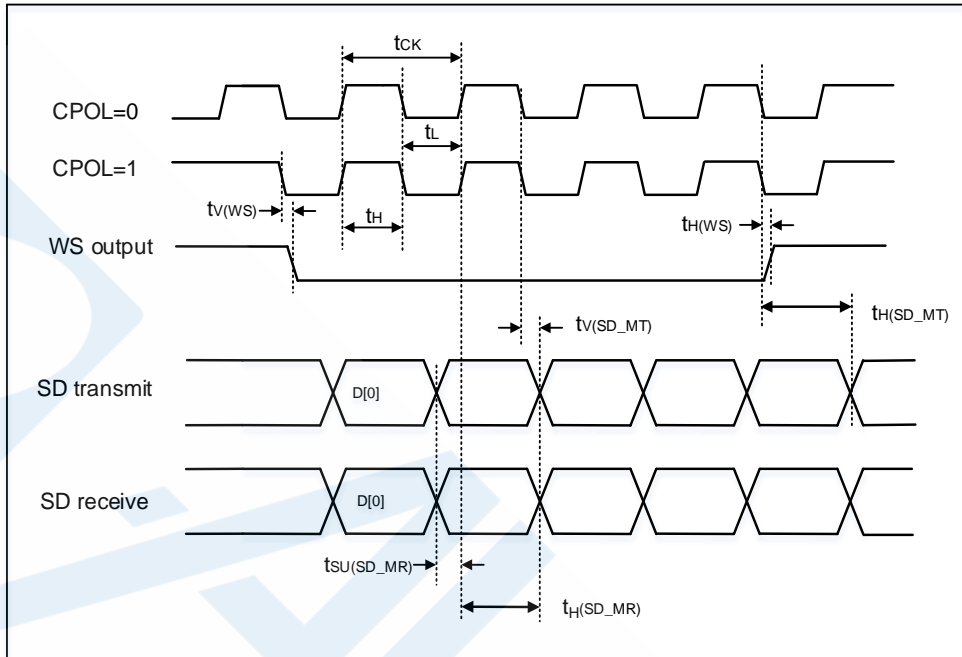
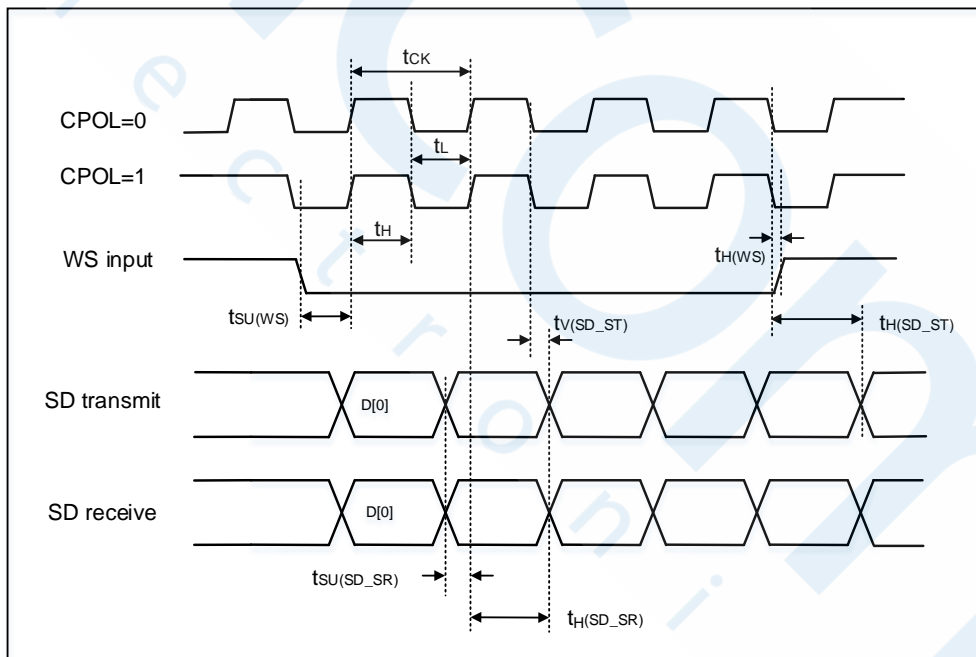

Figure 4-11. I2S timing diagram - slave mode



## 4.19 USART characteristics

Table 4-36. USART characteristics<sup>(1)</sup>

Symbol	Parameter	Conditions	Min	Typ	Max	Unit
f <sub>SCK</sub>	SCK clock frequency	—	—	—	36	MHz
t <sub>SCK(H)</sub>	SCK clock high time	—	13.89	—	—	ns
t <sub>SCK(L)</sub>	SCK clock low time	—	13.89	—	—	ns

(1) Guaranteed by design, not tested in production.

## 4.20 WDGT characteristics

Table 4-37. FWDGT min/max timeout period at 40 kHz (IRC40K)<sup>(1)</sup>

Prescaler divider	PR[2:0] bits	Min timeout RLD[11:0]=	Max timeout RLD[11:0]=	Unit
		0x000	0xFF	
1/4	000	0.025	409.525	ms
1/8	001	0.025	819.025	
1/16	010	0.025	1638.025	
1/32	011	0.025	3276.025	
1/64	100	0.025	6552.025	
1/128	101	0.025	13104.025	
1/256	110 or 111	0.025	26208.025	

(1) Guaranteed by design, not tested in production.

Table 4-38. WWDGT min-max timeout value at 72 MHz (f<sub>PCLK1</sub>)<sup>(1)</sup>

Prescaler divider	PSC[1:0]	Min timeout value	Unit	Max timeout value	Unit
		CNT[6:0] = 0x40		CNT[6:0] = 0x7F	
1/1	00	56.89	μs	3.64	ms
1/2	01	113.78		7.28	
1/4	10	227.56		14.56	
1/8	11	455.11		29.12	

(1) Guaranteed by design, not tested in production.

## 4.21 Parameter conditions

Unless otherwise specified, all values given for V<sub>DD</sub> = V<sub>DDA</sub> = 3.3 V, T<sub>A</sub> = 25 °C.

## 5 Package information

### 5.1 LQFP48 package outline dimensions

Figure 5-1. LQFP48 package outline

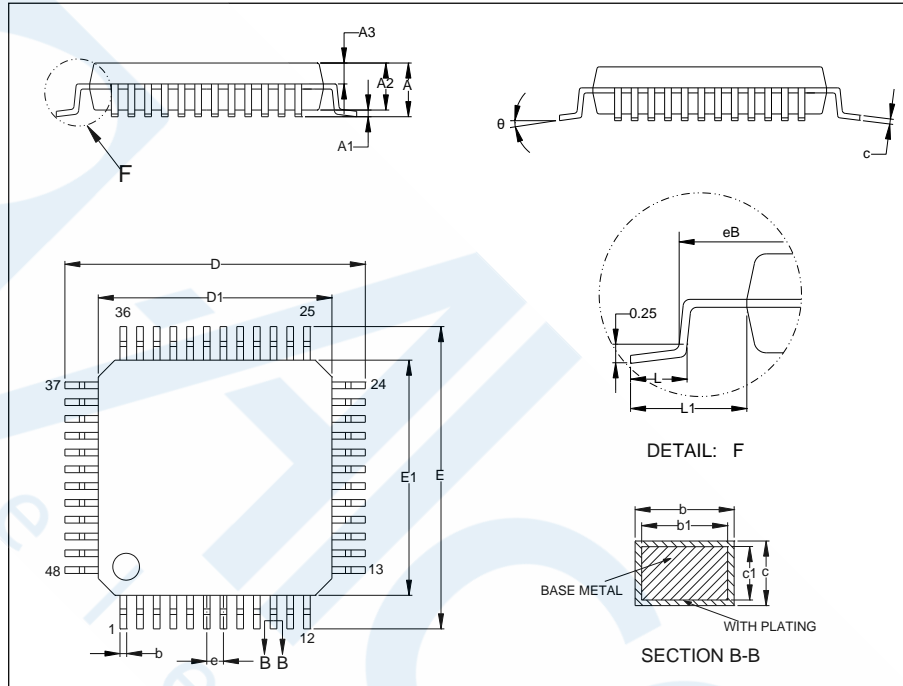
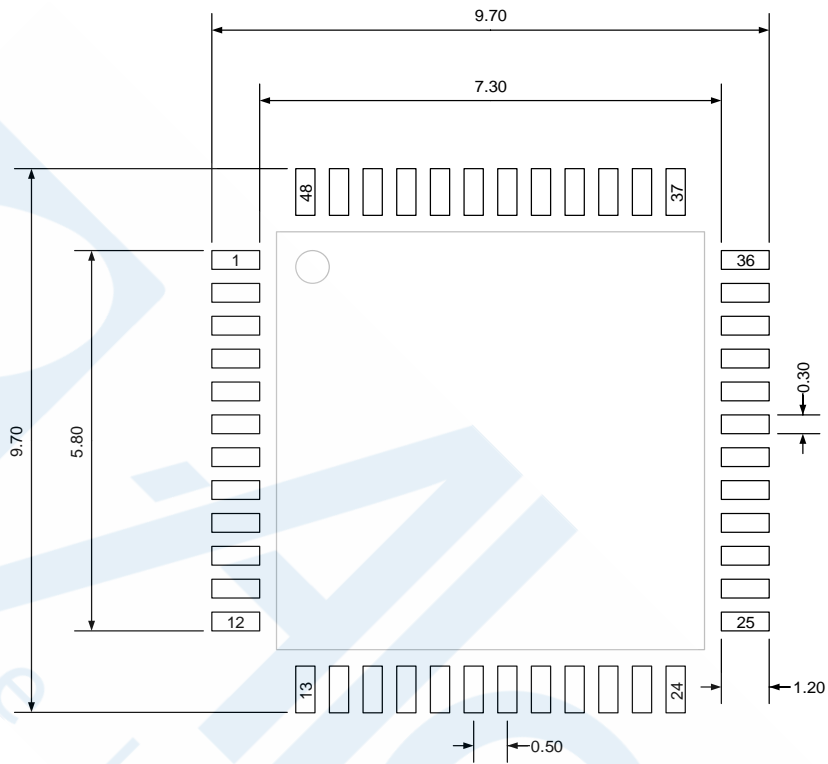

Table 5-1. LQFP48 package dimensions

Symbol	Min	Typ	Max
A	—	—	1.60
A1	0.05	—	0.15
A2	1.35	1.40	1.45
A3	0.59	0.64	0.69
b	0.18	—	0.26
b1	0.17	0.20	0.23
c	0.13	—	0.17
c1	0.12	0.13	0.14
D	8.80	9.00	9.20
D1	6.90	7.00	7.10
E	8.80	9.00	9.20
E1	6.90	7.00	7.10
e	—	0.50	—
eB	8.10	—	8.25
L	0.45	—	0.75
L1	—	1.00	—
$\theta$	0°	—	7°

(Original dimensions are in millimeters)

**Figure 5-2. LQFP48 recommended footprint**



(Original dimensions are in millimeters)

## 5.2 LQFP32 package outline dimensions

Figure 5-3. LQFP32 package outline

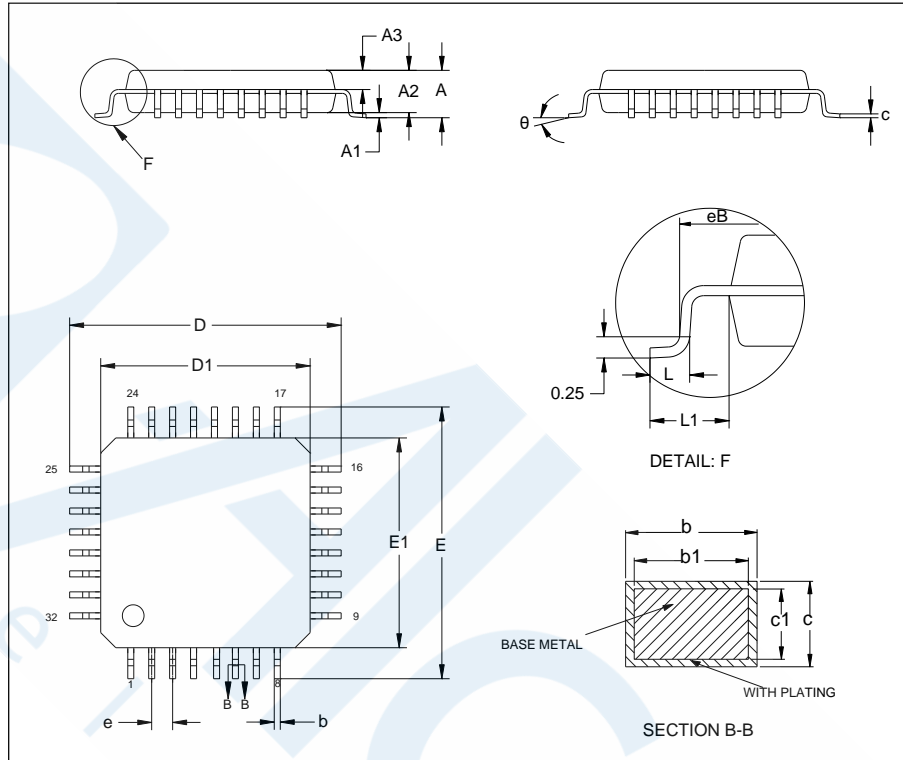
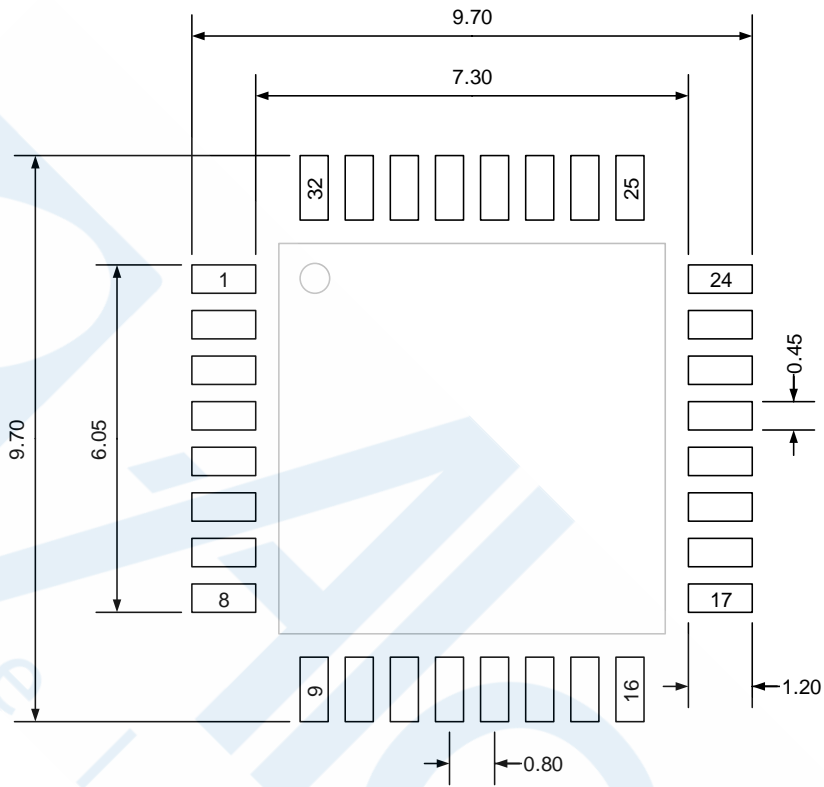

Table 5-2. LQFP32 package dimensions

Symbol	Min	Typ	Max
A	—	—	1.60
A1	0.05	—	0.15
A2	1.35	1.40	1.45
A3	0.59	0.64	0.69
b	0.33	—	0.41
b1	0.32	0.35	0.38
c	0.13	—	0.17
c1	0.12	0.13	0.14
D	8.80	9.00	9.20
D1	6.90	7.00	7.10
E	8.80	9.00	9.20
E1	6.90	7.00	7.10
e	—	0.80	—
eB	8.10	—	8.25
L	0.45	—	0.75
L1	—	1.00	—
$\theta$	0°	—	7°

(Original dimensions are in millimeters)

Figure 5-4. LQFP32 recommended footprint



(Original dimensions are in millimeters)

### 5.3 QFN32 package outline dimensions

Figure 5-5. QFN32 package outline

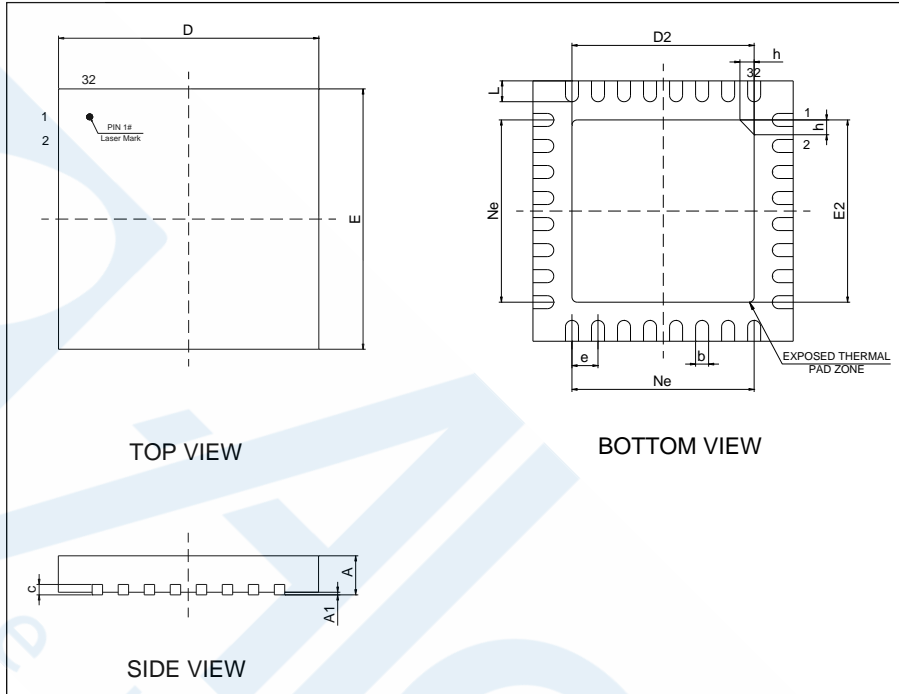

Table 5-3. QFN32 package dimensions

Symbol	Min	Typ	Max
A	0.70	0.75	0.80
A1	0	0.02	0.05
b	0.18	0.25	0.30
c	0.18	0.20	0.25
D	4.90	5.00	5.10
D2	3.40	3.50	3.60
E	4.90	5.00	5.10
E2	3.40	3.50	3.60
e	—	0.50	—
h	0.30	0.35	0.40
L	0.35	0.40	0.45
Ne	—	3.50	—

(Original dimensions are in millimeters)



Figure 5-6. QFN32 recommended footprint

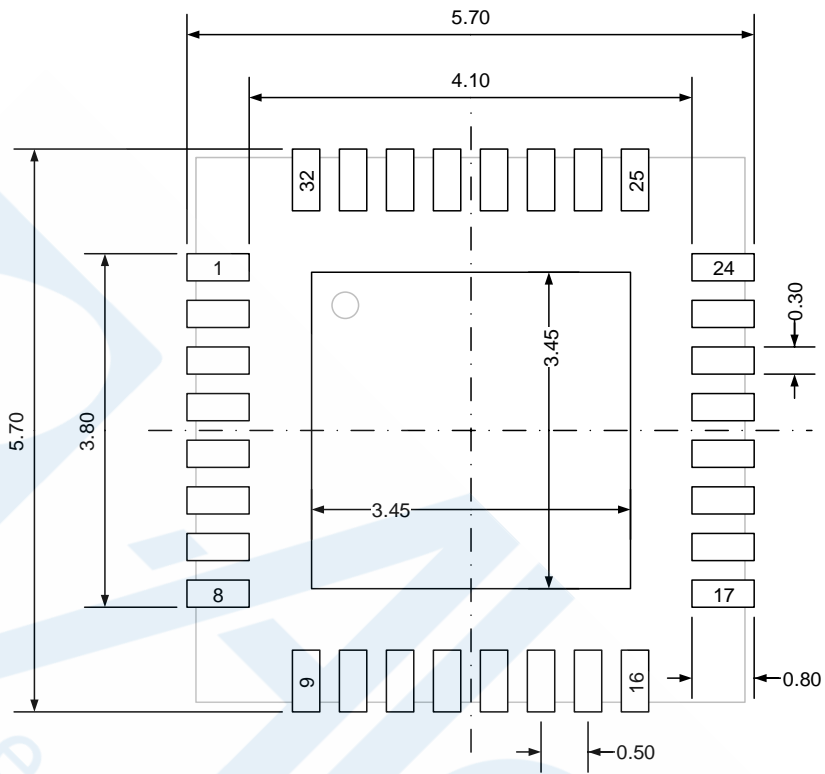

(Original dimensions are in millimeters)

## 5.4 QFN28 package outline dimensions

Figure 5-7. QFN28 package outline

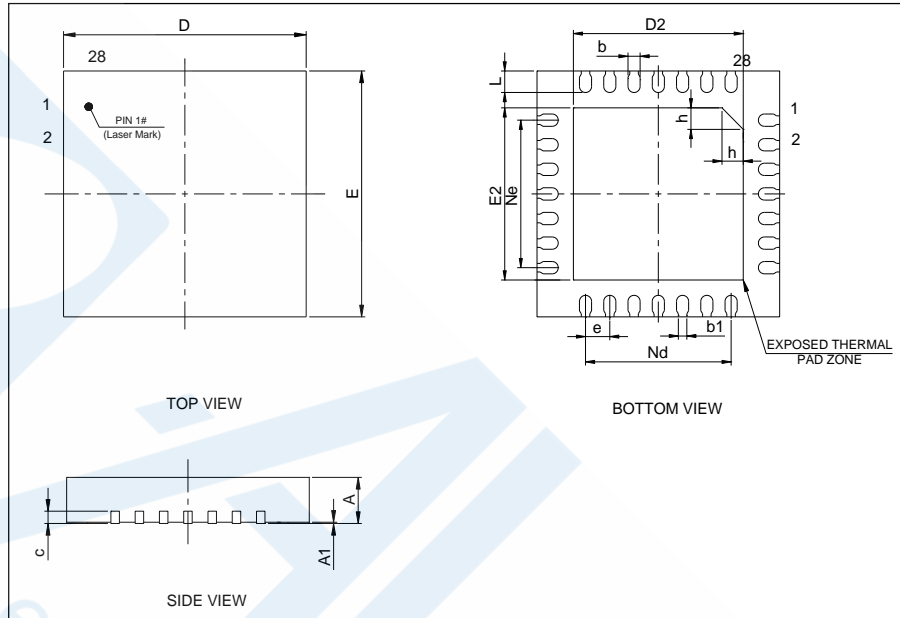
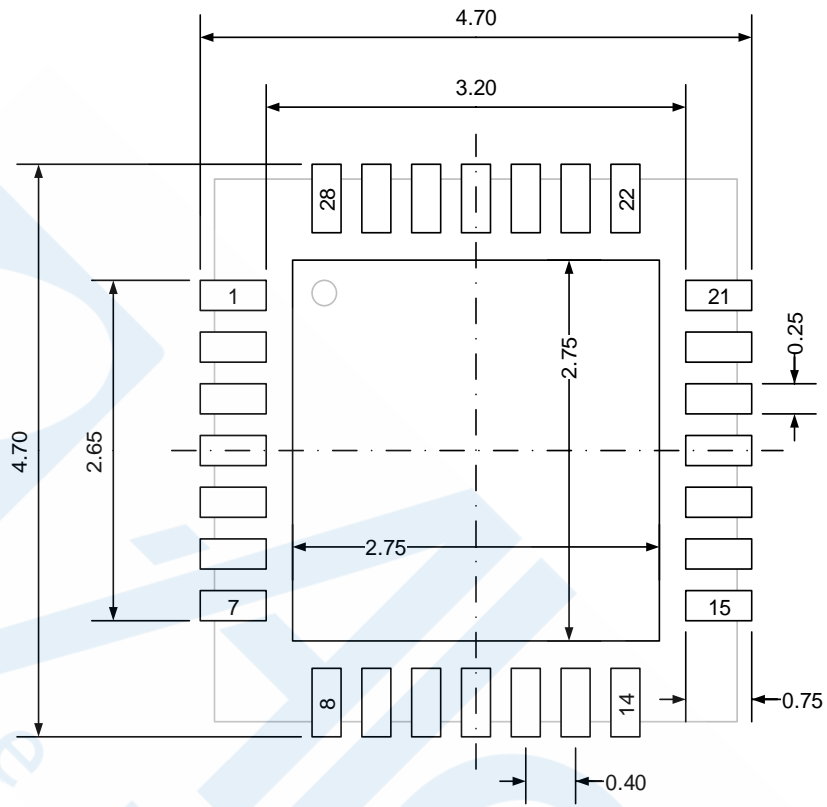

Table 5-4. QFN28 package dimensions

Symbol	Min	Typ	Max
A	0.70	0.75	0.80
A1	0	0.02	0.05
b	0.15	0.20	0.25
b1	—	0.14	—
c	0.18	0.20	0.25
D	3.90	4.00	4.10
D2	2.70	2.80	2.90
E	3.90	4.00	4.10
E2	2.70	2.80	2.90
e	—	0.40	—
h	0.30	0.35	0.40
L	0.30	0.35	0.40
Nd	—	2.40	—
Ne	—	2.40	—

(Original dimensions are in millimeters)

Figure 5-8. QFN28 recommended footprint



(Original dimensions are in millimeters)

## 5.5 TSSOP20 package outline dimensions

Figure 5-9. TSSOP20 package outline

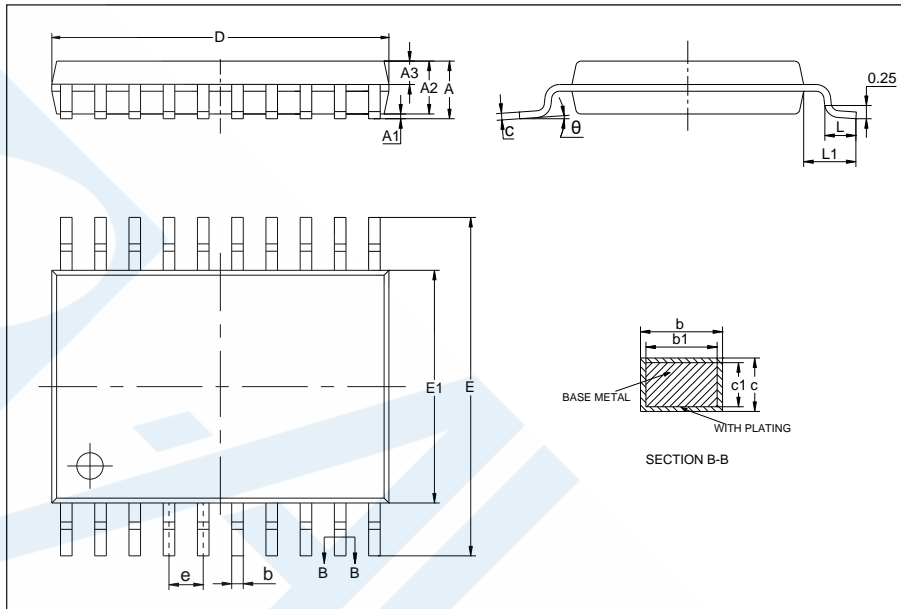
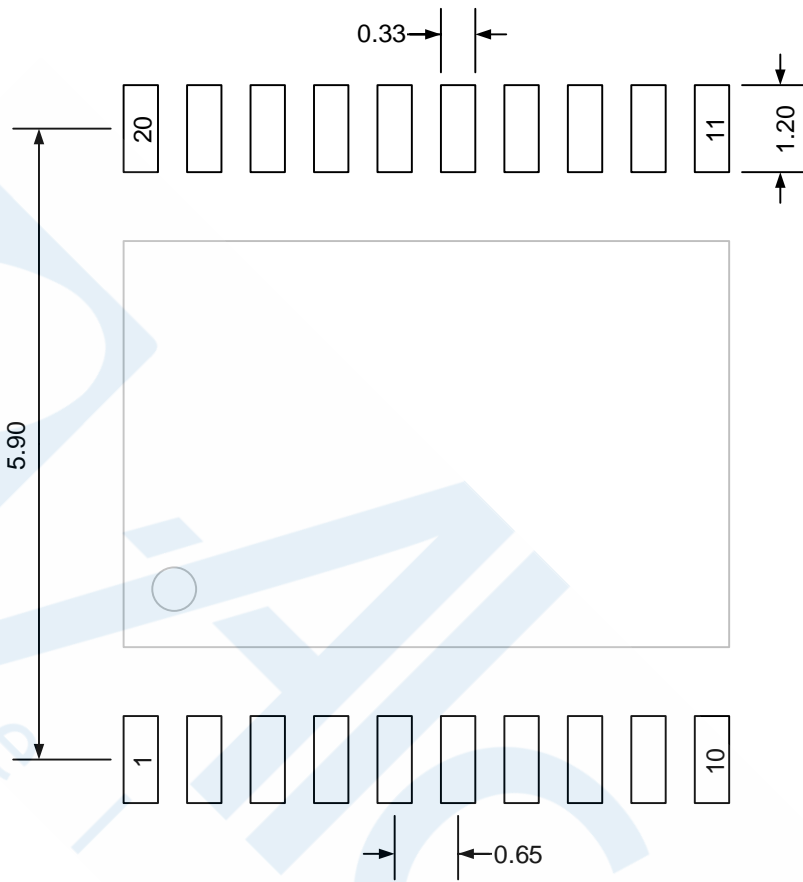

Table 5-5. TSSOP20 package dimensions

Symbol	Min	Typ	Max
A	—	—	1.20
A1	0.05	—	0.15
A2	0.80	1.00	1.05
A3	0.39	0.44	0.49
b	0.20	—	0.28
b1	0.19	0.22	0.25
c	0.13	—	0.17
c1	0.12	0.13	0.14
D	6.40	6.50	6.60
E	6.20	6.40	6.60
E1	4.30	4.40	4.50
e	—	0.65	—
L	0.45	0.60	0.75
L1	—	1.00	—
$\theta$	0°	—	8°

(Original dimensions are in millimeters)

Figure 5-10. TSSOP20 recommended footprint



(Original dimensions are in millimeters)

## 5.6 LGA20 package outline dimensions

Figure 5-11. LGA20 package outline

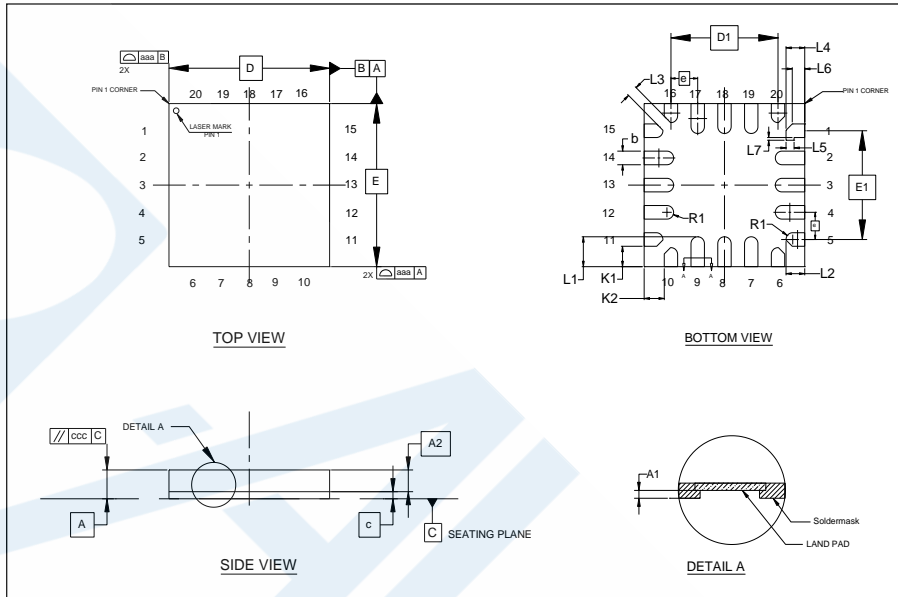
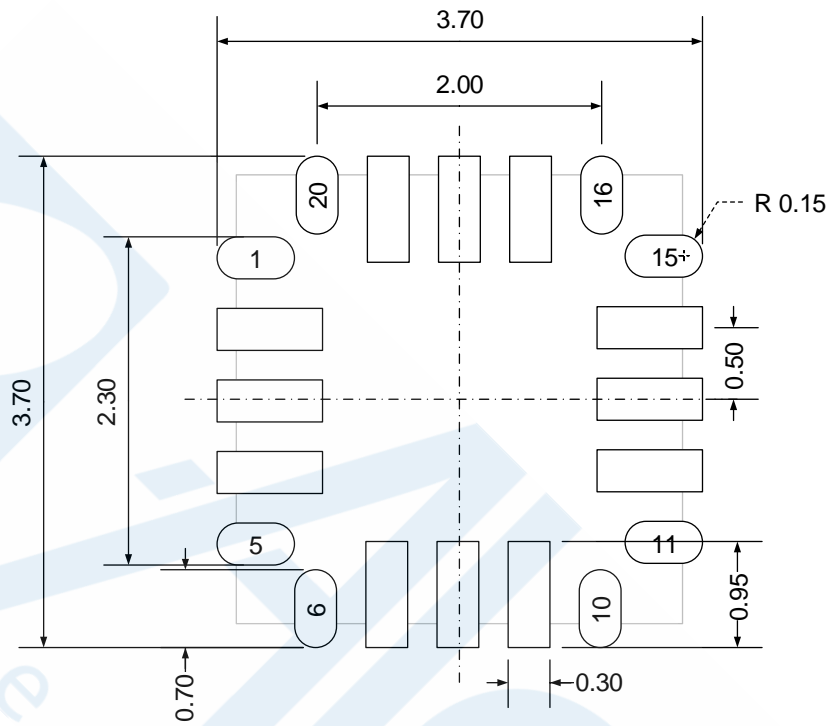

Table 5-6. LGA20 package dimensions

Symbol	Min	Typ	Max
A	0.51	0.56	0.61
A1	—	0.015	0.022
A2	0.35	0.40	0.45
b	0.20	0.25	0.30
c	0.13	0.16	0.19
D	2.90	3.00	3.10
D1	1.95	2.00	2.05
E	2.90	3.00	3.10
E1	1.95	2.00	2.05
e	—	0.50	—
K1	—	0.375	—
K2	—	0.375	—
L1	0.50	0.55	0.60
L2	0.30	0.35	0.40
L3	—	0.20	—
L4	0.30	0.35	0.40
L5	—	0.125	—
L6	—	0.234	—
L7	—	0.05	—
R1	—	0.125	—
aaa	—	0.10	—
ccc	—	0.08	—

(Original dimensions are in millimeters)

Figure 5-12. LGA20 recommended footprint



(Original dimensions are in millimeters)

## 5.7 Thermal characteristics

Thermal resistance is used to characterize the thermal performance of the package device, which is represented by the Greek letter “ $\theta$ ”. For semiconductor devices, thermal resistance represents the steady-state temperature rise of the chip junction due to the heat dissipated on the chip surface.

$\theta_{JA}$ : Thermal resistance, junction-to-ambient.

$\theta_{JB}$ : Thermal resistance, junction-to-board.

$\theta_{JC}$ : Thermal resistance, junction-to-case.

$\Psi_{JB}$ : Thermal characterization parameter, junction-to-board.

$\Psi_{JT}$ : Thermal characterization parameter, junction-to-top center.

$$\theta_{JA}=(T_J-T_A)/P_D \tag{5-1}$$

$$\theta_{JB}=(T_J-T_B)/P_D \tag{5-2}$$

$$\theta_{JC}=(T_J-T_C)/P_D \tag{5-3}$$

Where,  $T_J$  = Junction temperature.

$T_A$  = Ambient temperature

$T_B$  = Board temperature

$T_C$  = Case temperature which is monitoring on package surface

$P_D$  = Total power dissipation

$\theta_{JA}$  represents the resistance of the heat flows from the heating junction to ambient air. It is an indicator of package heat dissipation capability. Lower  $\theta_{JA}$  can be considerate as better overall thermal performance.  $\theta_{JA}$  is generally used to estimate junction temperature.

$\theta_{JB}$  is used to measure the heat flow resistance between the chip surface and the PCB board.

$\theta_{JC}$  represents the thermal resistance between the chip surface and the package top case.

$\theta_{JC}$  is mainly used to estimate the heat dissipation of the system (using heat sink or other heat dissipation methods outside the device package).

**Table 5-7. Package thermal characteristics<sup>(1)</sup>**

Symbol	Condition	Package	Value	Unit
$\theta_{JA}$	Natural convection, 2S2P PCB	LQFP48	69.64	°C/W
		LQFP32	55.26	
		QFN32	42.58	
		QFN28	47.32	
		TSSOP20	67.24	
		LGA20	96.08	
$\theta_{JB}$	Cold plate, 2S2P PCB	LQFP48	43.16	°C/W



Symbol	Condition	Package	Value	Unit
		LQFP32	26.24	
		QFN32	12.22	
		QFN28	12.97	
		TSSOP20	37.72	
		LGA20	58.46	
$\theta_{JC}$	Cold plate, 2S2P PCB	LQFP48	25.36	°C/W
		LQFP32	25.23	
		QFN32	16.76	
		QFN28	20.26	
		TSSOP20	25.06	
		LGA20	31.54	
$\Psi_{JB}$	Natural convection, 2S2P PCB	LQFP48	47.75	°C/W
		LQFP32	32.03	
		QFN32	12.81	
		QFN28	13.07	
		TSSOP20	49.07	
		LGA20	58.61	
$\Psi_{JT}$	Natural convection, 2S2P PCB	LQFP48	2.45	°C/W
		LQFP32	2.06	
		QFN32	0.69	
		QFN28	0.75	
		TSSOP20	2.37	
		LGA20	1.83	

(1). Thermal characteristics are based on simulation, and meet JEDEC specification.

## 6 Ordering information

**Table 6-1. Part ordering code for GD32E235xx devices**

Ordering code	Flash (KB)	Package	Package type	Temperature operating range
GD32E235CBT6	128	LQFP48	Green	Industrial -40 °C to +85 °C
GD32E235C8T6	64	LQFP48	Green	Industrial -40 °C to +85 °C
GD32E235C6T6	32	LQFP48	Green	Industrial -40 °C to +85 °C
GD32E235C4T6	16	LQFP48	Green	Industrial -40 °C to +85 °C
GD32E235KBT6	128	LQFP32	Green	Industrial -40 °C to +85 °C
GD32E235K8T6	64	LQFP32	Green	Industrial -40 °C to +85 °C
GD32E235K6T6	32	LQFP32	Green	Industrial -40 °C to +85 °C
GD32E235K4T6	16	LQFP32	Green	Industrial -40 °C to +85 °C
GD32E235KBU6	128	QFN32	Green	Industrial -40 °C to +85 °C
GD32E235K8U6	64	QFN32	Green	Industrial -40 °C to +85 °C
GD32E235K6U6	32	QFN32	Green	Industrial -40 °C to +85 °C
GD32E235K4U6	16	QFN32	Green	Industrial -40 °C to +85 °C
GD32E235G8U6TR	64	QFN28	Green	Industrial -40 °C to +85 °C
GD32E235G6U6TR	32	QFN28	Green	Industrial -40 °C to +85 °C
GD32E235G4U6TR	16	QFN28	Green	Industrial -40 °C to +85 °C
GD32E235F8V6TR	64	LGA20	Green	Industrial -40 °C to +85 °C
GD32E235F6V6TR	32	LGA20	Green	Industrial -40 °C to +85 °C
GD32E235F4V6TR	16	LGA20	Green	Industrial -40 °C to +85 °C
GD32E235F8P6TR	64	TSSOP20	Green	Industrial -40 °C to +85 °C
GD32E235F6P6TR	32	TSSOP20	Green	Industrial -40 °C to +85 °C
GD32E235F4P6TR	16	TSSOP20	Green	Industrial -40 °C to +85 °C

## 7 Revision history

Table 7-1. Revision history

Revision No.	Description	Date
1.0	Initial Release	Feb.1, 2024

## Important Notice

This document is the property of GigaDevice Semiconductor Inc. and its subsidiaries (the "Company"). This document, including any product of the Company described in this document (the "Product"), is owned by the Company under the intellectual property laws and treaties of the People's Republic of China and other jurisdictions worldwide. The Company reserves all rights under such laws and treaties and does not grant any license under its patents, copyrights, trademarks, or other intellectual property rights. The names and brands of third party referred thereto (if any) are the property of their respective owner and referred to for identification purposes only.

The Company makes no warranty of any kind, express or implied, with regard to this document or any Product, including, but not limited to, the implied warranties of merchantability and fitness for a particular purpose. The Company does not assume any liability arising out of the application or use of any Product described in this document. Any information provided in this document is provided only for reference purposes. It is the responsibility of the user of this document to properly design, program, and test the functionality and safety of any application made of this information and any resulting product. Except for customized products which has been expressly identified in the applicable agreement, the Products are designed, developed, and/or manufactured for ordinary business, industrial, personal, and/or household applications only. The Products are not designed, intended, or authorized for use as components in systems designed or intended for the operation of weapons, weapons systems, nuclear installations, atomic energy control instruments, combustion control instruments, airplane or spaceship instruments, transportation instruments, traffic signal instruments, life-support devices or systems, other medical devices or systems (including resuscitation equipment and surgical implants), pollution control or hazardous substances management, or other uses where the failure of the device or Product could cause personal injury, death, property or environmental damage ("Unintended Uses"). Customers shall take any and all actions to ensure using and selling the Products in accordance with the applicable laws and regulations. The Company is not liable, in whole or in part, and customers shall and hereby do release the Company as well as its suppliers and/or distributors from any claim, damage, or other liability arising from or related to all Unintended Uses of the Products. Customers shall indemnify and hold the Company as well as its suppliers and/or distributors harmless from and against all claims, costs, damages, and other liabilities, including claims for personal injury or death, arising from or related to any Unintended Uses of the Products.

Information in this document is provided solely in connection with the Products. The Company reserves the right to make changes, corrections, modifications or improvements to this document and Products and services described herein at any time, without notice.