

TIELEE® 天立电机

Tianli Electrical Machinery (Ningbo) Co., Ltd

ISO9001 ISO45001
ISO14001 IATF16949



REACH

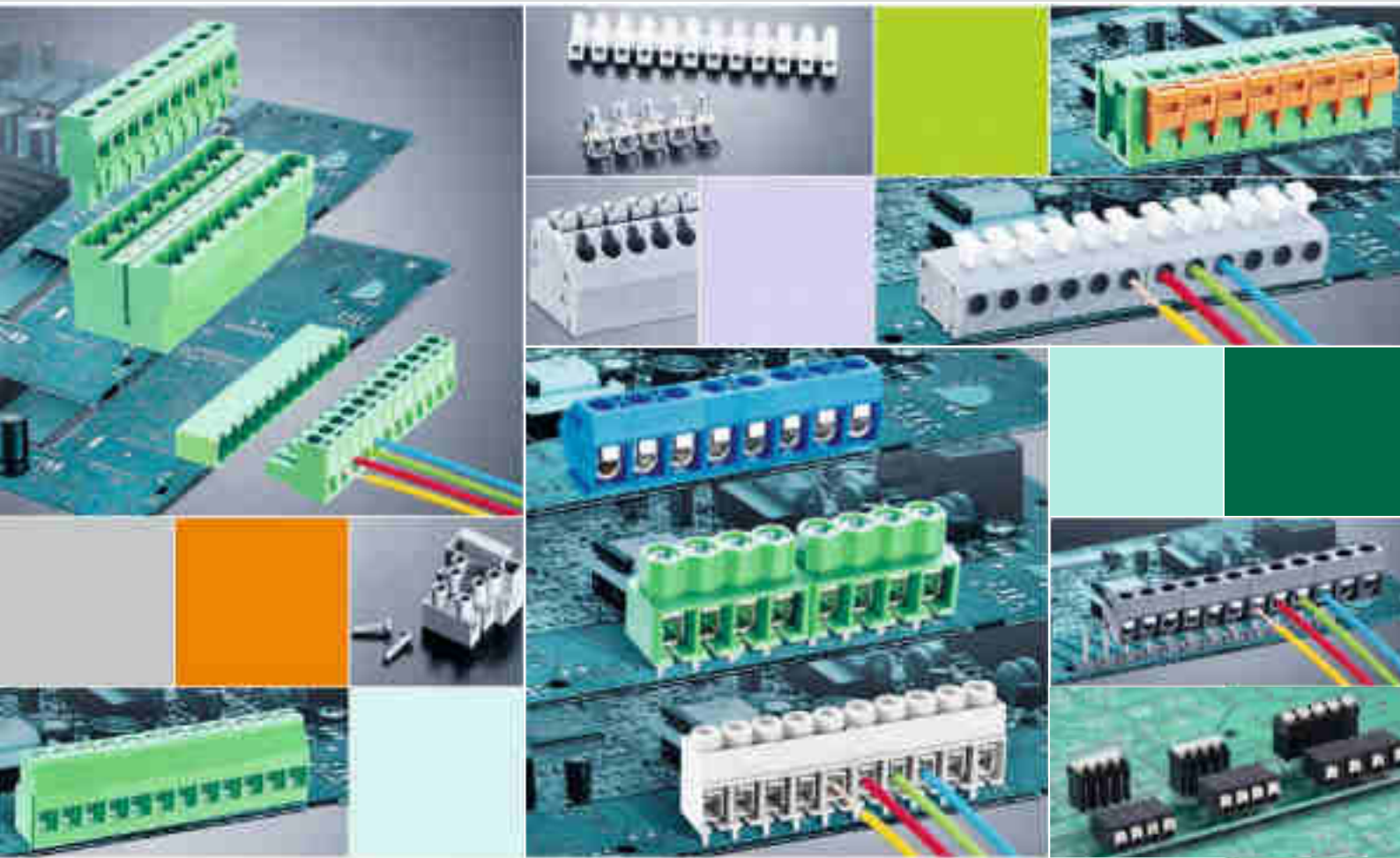

本目录产品规格数据仅供参考，天立对此目录中规格数据作修改，恕不另行通知

The technical data of the products in this catalogue are only for reference, Tianli reserves the rights for specification update or change.



Singel 3 | B-2550 Kontich | Belgium | Tel. +32 (0)3 458 30 33 | info@alcom.be | www.alcom.be

Rivium 1e straat 52 | 2909 LE Capelle aan den IJssel | The Netherlands | Tel. +31 (0)10 288 25 00 | info@alcom.nl | www.alcom.nl







TC-23.03







企业简介 Company profile

天立电机(宁波)有限公司成立于1998年,是亚洲领先的接线端子和金属零件制造商之一,为安防系统、工业自动化、电力、照明、电信、电源、轨道交通、新能源等行业的客户提供高质量的产品和服务。总部及生产基地位于宁波杭州湾新区,距上海仅2小时车程。货物运输和客户来访都相当便利。

天立已获得 ISO9001, ISO14001, ISO45001 和 IATF16949 管理系统认证,并拥有 UL 和 VDE 授权实验室。产品符合 RoHS 和 REACH 并获得了 , , , ,  等认证。











为了保持进步赢得客户的青睐,天立对 CAD 设计,模具开发设备,产品注塑冲设备和员工技能培训有很大的投入。经过多年的努力,天立的销售网络涵盖全世界,并将不断为客户提供高质量的产品和专业服务,共创繁荣。

Founded in 1998, Tianli Electrical Machinery (Ningbo) Co., Ltd. is one of the leading manufacturers of terminal blocks and metal parts in Asia, providing high quality products and service to customers of security system, industrial automation, electric power, lighting, telecommunication, power supply, rail transportation, new energy and so on. The headquarter and facility is located in Hangzhou Bay New Zone, Ningbo, only 2 hours to Shanghai. The transportation is very convenient here for goods shipment & customer visiting.

Tianli has been granted ISO9001, ISO14001, ISO45001 and IATF16949 management system certifications and own the UL and VDE authorized laboratory. The products are approved by , , , , , RoHS and REACH.

To keep advancement and win the favor of customers, Tianli made large investment in CAD design, mould development equipments, injection/stamping machines and staff skills training. With years of efforts, Tianli's sales network covers the whole world, and will continuously supply customers with high quality products and professional service, reaching the achievement of win-win prosperity.

目录 Index

04-19	TLPS SERIES - Plug(Female) for Pluggable Terminal Block Pitch: 2.5mm, 2.54mm, 3.50mm, 3.81 mm, 5.00mm, 5.08mm, 7.50mm, 7.62mm, 10.16mm, 15.00mm	
20-43	TLP SERIES - Header(Male) for Pluggable Terminal Block Pitch: 2.5mm, 2.54mm, 3.50mm, 3.81 mm, 5.00mm, 5.08mm, 7.50mm, 7.62mm, 10.16mm, 15.00mm	
44-53	TLC SERIES - Spring-cage Clamp Terminal Block Pitch: 2.50mm, 3.50mm, 3.81mm, 5.00mm, 5.08mm, 7.50mm, 7.62mm	
54-61	TL SERIES - Wire Protector PCB Screw Terminal Block Pitch: 3.50mm, 3.81 mm, 5.00mm, 5.08mm, 7.50mm, 7.62mm	
62-76	TL SERIES - Raising Clamp PCB Screw Terminal Block Pitch: 2.54mm, 3.50mm, 3.81 mm, 5.00mm, 5.08mm, 6.35mm, 7.50mm, 9.52mm, 10.16mm, 12.00mm, 12.70mm, 15.00mm	
78-91	TLM SERIES - PCB Spring Terminal Block Pitch: 2.50mm, 2.54mm, 3.50mm, 5.00mm, 5.08mm, 7.00mm, 7.50mm, 7.62mm, 10.00mm, 10.16mm	
92-97	TLB SERIES - Terminal Strip Pitch: 8.0mm, 10.0mm, 12.0mm, 13.5mm, 11mm, 14mm, 14.5mm, 16.5mm, 18.5mm	
98-101	TPK SERIES - Panel Feed-through Terminal Block	
102-103	TLF SERIES - Fuse Terminal Block	
104-105	FH SERIES - Fuse Holder	
106-108	TQQ & TQS SERIES - PCB Fast Connector	

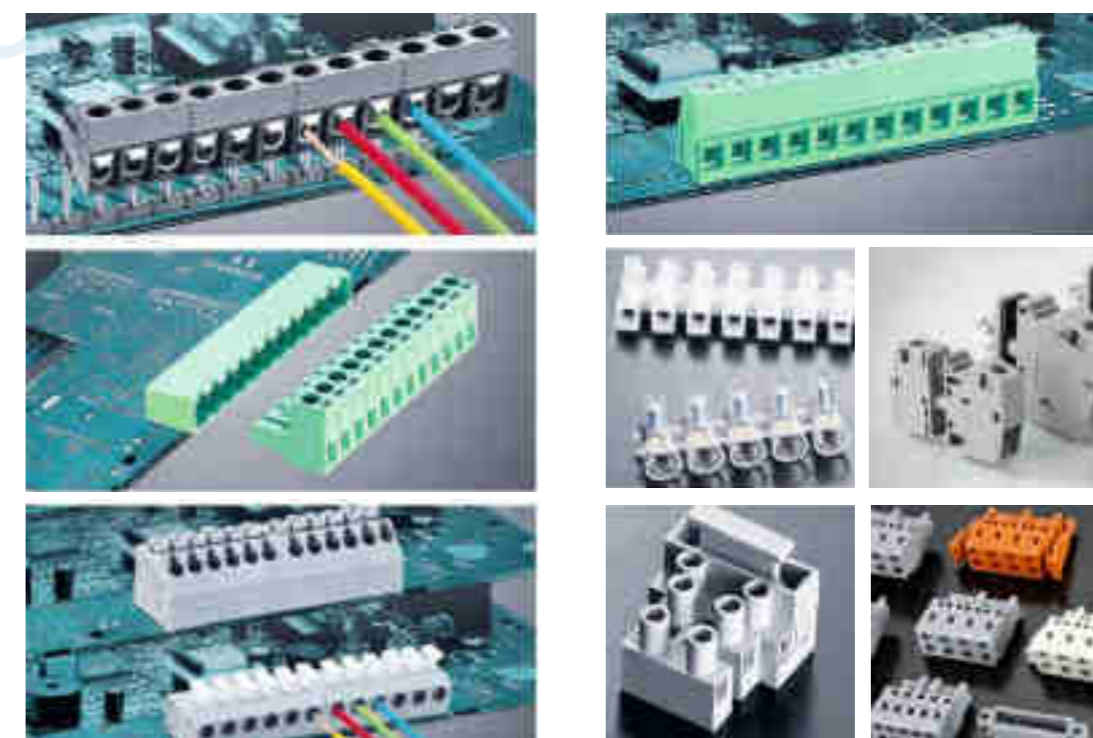

TLPS SERIES – Plug(Female) for Pluggable Terminal Block

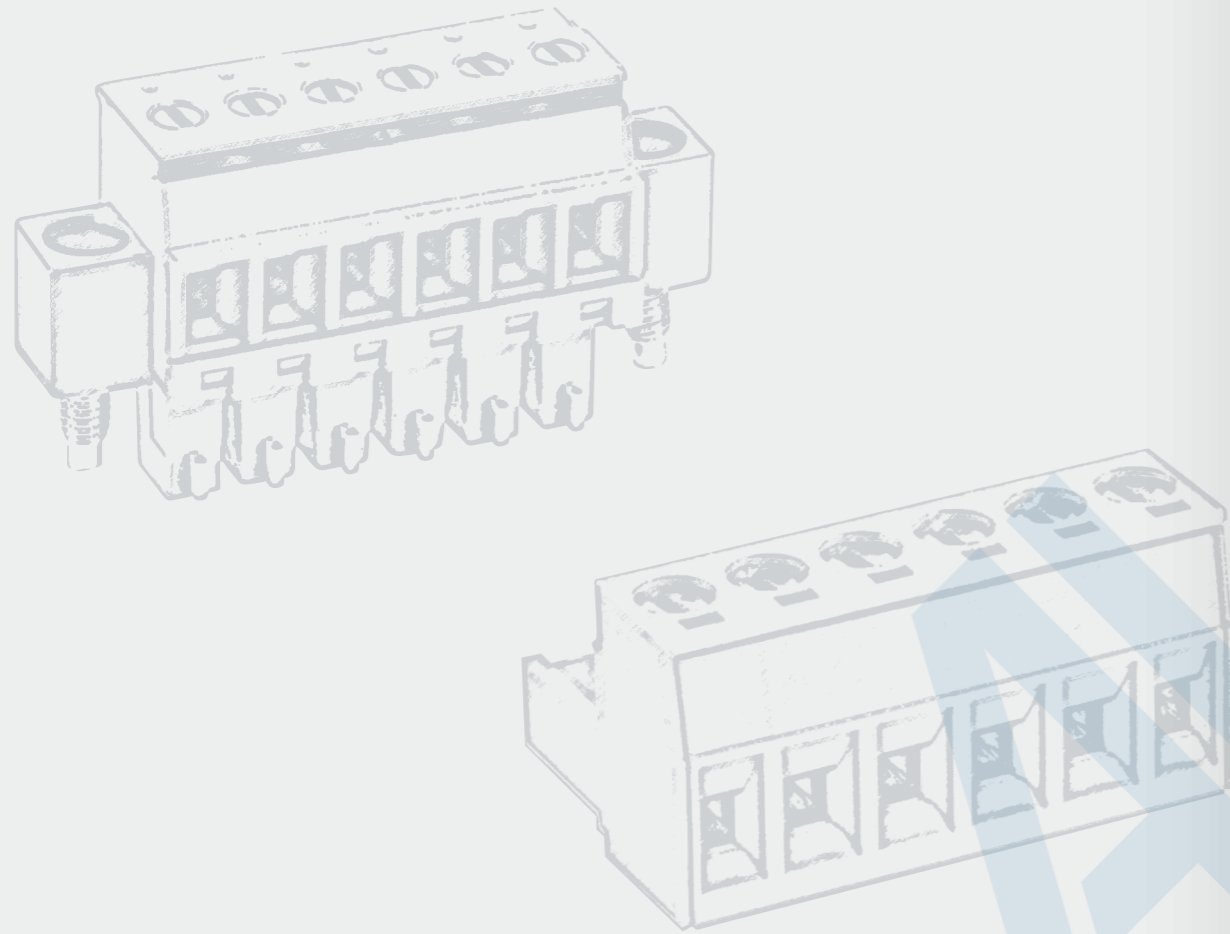

How to order

TLPS(D)(W)(L) - □□□ V/R(L) - □□□□ - □□ P □ - □□

- Screw: S=Slot screw, C=Cross screw
- Color:K=Black, G(G12)=Green, L=Blue, B=Beige...
- 5=Double pitch, None=Standard pitch
- Poles
- Special code
- V=180°, R=90°, L=hook on back side
- Series number
- Pitch: 0=3.50, 1=3.81, 2=5.00, 3=5.08, 4=7.50, 5=7.62, 8=10.16, 9=15.00
- D=Double row, W=With flange, L= with locking flange

TLPS-006V

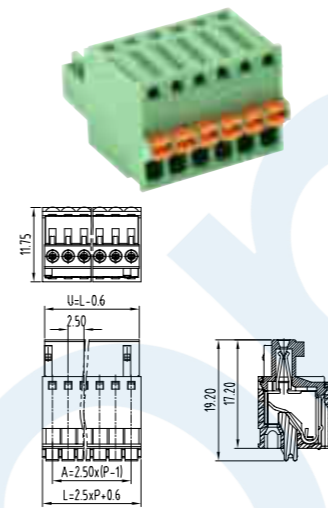

技术数据 Technical data	
Pitch (间距):	2.50mm
Approval (认证):	UL
Rated voltage (电压):	150V
Rated current (电流):	5A
Wire range (线径):	28~20AWG
料号 Part Number	
极数 (Poles)	型号 (Model)
02	TLPS-006V-02P
:	:
24	TLPS-006V-24P

TLPS-001V(TLPS-100V)

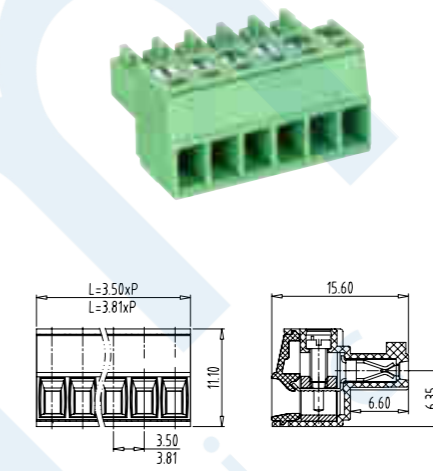

技术数据 Technical data	
Pitch (间距):	3.50mm(3.81mm)
Approval (认证):	UL
Rated voltage (电压):	300V
Rated current (电流):	8A 10A
Wire range (线径):	30~14AWG 1.5mm ²
Screw (螺丝):	M2
料号 Part Number	
极数 (Poles)	型号 (Model)
02	TLPS-001V-02P(TLPS-100V-02P)
:	:
24	TLPS-001V-24P(TLPS-100V-24P)

TLPSW-001V(TLPSW-100V)

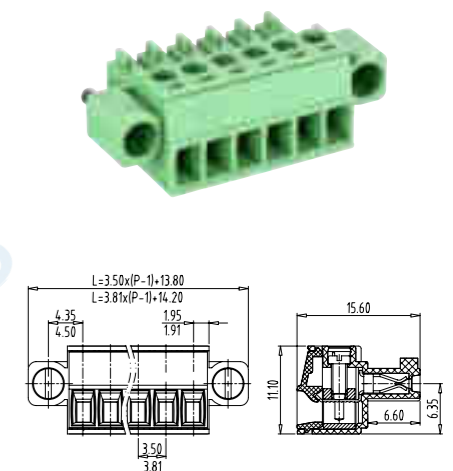

技术数据 Technical data	
Pitch (间距):	3.50mm(3.81mm)
Approval (认证):	UL
Rated voltage (电压):	300V 150V
Rated current (电流):	8A 10A
Wire range (线径):	30~14AWG 1.5mm ²
Screw (螺丝):	M2
料号 Part Number	
极数 (Poles)	型号 (Model)
02	TLPSW-001V-02P(TLPSW-100V-02P)
:	:
24	TLPSW-001V-24P(TLPSW-100V-24P)

TLPS-001R(TLPS-100R)

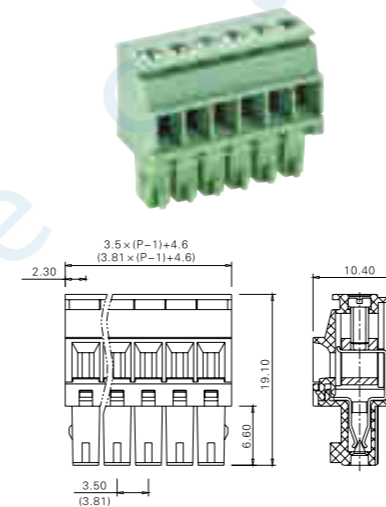

技术数据 Technical data	
Pitch (间距):	3.50mm(3.81mm)
Approval (认证):	UL
Rated voltage (电压):	300V
Rated current (电流):	8A
Wire range (线径):	30~14AWG
Screw (螺丝):	M2
料号 Part Number	
极数 (Poles)	型号 (Model)
02	TLPS-001R-02P(TLPS-100R-02P)
:	:
24	TLPS-001R-24P(TLPS-100R-24P)

TLPSW-001R(TLPSW-100R)

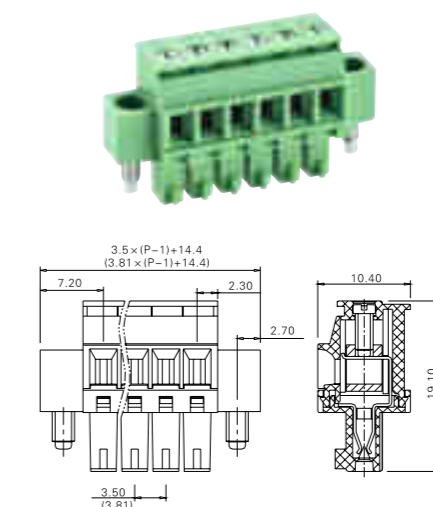

技术数据 Technical data	
Pitch (间距):	3.50mm(3.81mm)
Approval (认证):	UL
Rated voltage (电压):	300V
Rated current (电流):	8A
Wire range (线径):	30~14AWG
Screw (螺丝):	M2
料号 Part Number	
极数 (Poles)	型号 (Model)
02	TLPSW-001R-02P(TLPSW-100R-02P)
:	:
24	TLPSW-001R-24P(TLPSW-100R-24P)

TLPS-001RL(TLPS-100RL)

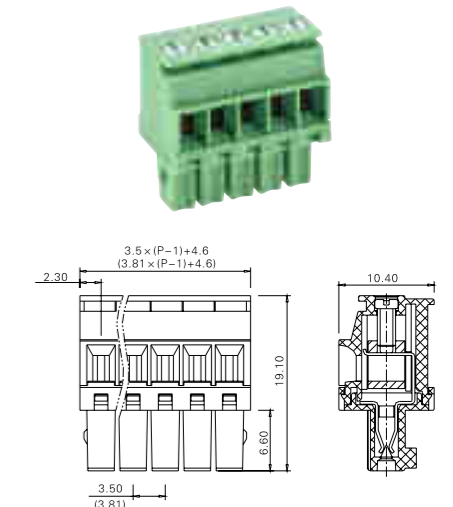

技术数据 Technical data	
Pitch (间距):	3.50mm(3.81mm)
Approval (认证):	UL
Rated voltage (电压):	300V
Rated current (电流):	8A
Wire range (线径):	30~14AWG
Screw (螺丝):	M2
料号 Part Number	
极数 (Poles)	型号 (Model)
02	TLPS-001 RL-02P(TLPS-100RL-02P)
:	:
24	TLPS-001 RL-24P(TLPS-100RL-24P)

TLPSW-001RL(TLPSW-100RL)

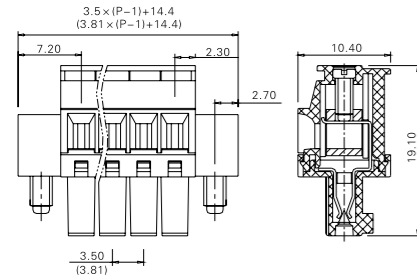

技术数据 Technical data	
Pitch (间距):	3.50mm(3.81mm)
Approval (认证):	UL, CE, Ex, SR, CQC
Rated voltage (电压):	300V
Rated current (电流):	8A
Wire range (线径):	30-14AWG
Screw (螺丝):	M2
料号 Part Number	
极数 (Poles)	型号 (Model)
02	TLPSW-001RL-02P(TLPSW-100RL-02P)
:	:
24	TLPSW-001RL-24P(TLPSW-100RL-24P)

TLPS-003

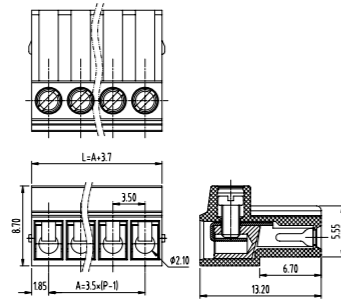

技术数据 Technical data	
Pitch (间距):	3.50mm
Approval (认证):	UL, CE, Ex, SR, CQC
Rated voltage (电压):	300V
Rated current (电流):	10A
Wire range (线径):	30-16AWG
Screw (螺丝):	M2.0
料号 Part Number	
极数 (Poles)	型号 (Model)
02	TLPS-003-02P
:	:
24	TLPS-003-24P

TLPS-011(TLPS-111)

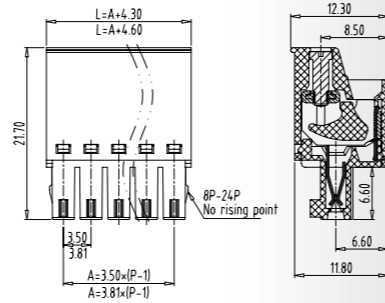
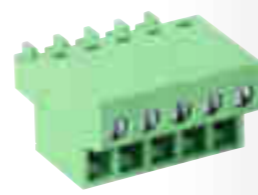

技术数据 Technical data	
Pitch (间距):	3.50mm(3.81mm)
Approval (认证):	UL, CE, Ex, SR, CQC
Rated voltage (电压):	300V 320V
Rated current (电流):	8A 10A
Wire range (线径):	30-14AWG 0.2-1.5mm ²
Screw (螺丝):	M2
料号 Part Number	
极数 (Poles)	型号 (Model)
02	TLPS-011-02P(TLPS-111-02P)
:	:
24	TLPS-011-24P(TLPS-111-24P)

TLPHSWA-112

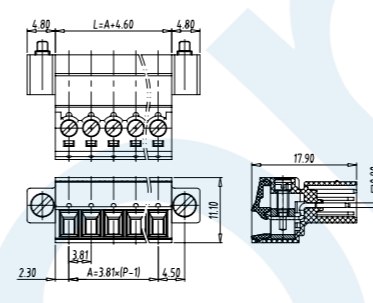

技术数据 Technical data	
Pitch (间距):	3.81mm
Approval (认证):	UL, CE, Ex, SR, CQC
Rated voltage (电压):	300V 320V
Rated current (电流):	8A 10A
Wire range (线径):	30-14AWG 0.2-1.5mm ²
Screw (螺丝):	M2
料号 Part Number	
极数 (Poles)	型号 (Model)
02	TLPHSWA-112-02P
:	:
24	TLPHSWA-112-24P

TLPS-009V(TLPS-109V)

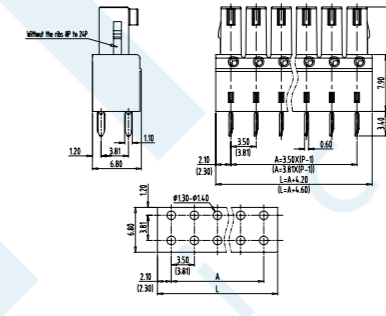
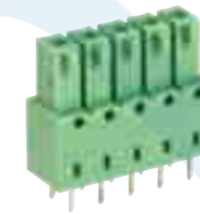

技术数据 Technical data	
Pitch (间距):	3.50mm(3.81mm)
Approval (认证):	UL, CE, Ex, SR, CQC (3.50mm Applying)
Rated voltage (电压):	300V 320V
Rated current (电流):	8A 10A
PCB hole Dia(PCB直径):	Φ 1.3mm-Φ 1.4mm
料号 Part Number	
极数 (Poles)	型号 (Model)
02	TLPS-009V-02P(TLPS-109V-02P)
:	:
24	TLPS-009V-24P(TLPS-109V-24P)

TLPS-009R(TLPS-109R)

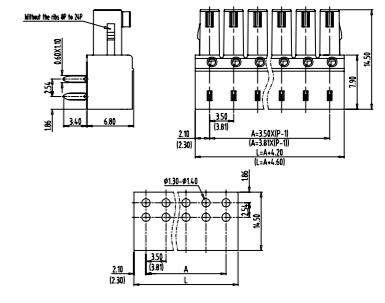
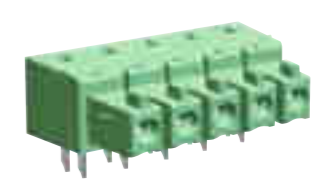

技术数据 Technical data	
Pitch (间距):	3.50mm(3.81mm)
Approval (认证):	UL, CE, Ex, SR, CQC (3.50mm Applying)
Rated voltage (电压):	300V 320V
Rated current (电流):	8A 10A
PCB hole Dia(PCB直径):	Φ 1.3mm-Φ 1.4mm
料号 Part Number	
极数 (Poles)	型号 (Model)
02	TLPS-009R-02P(TLPS-109R-02P)
:	:
24	TLPS-009R-24P(TLPS-109R-24P)

TLPSW-011(TLPSW-111)

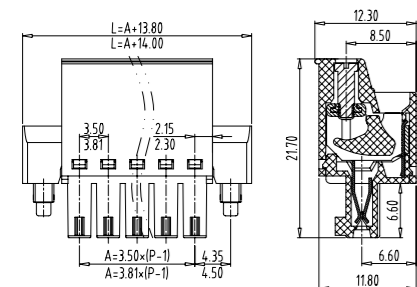

技术数据 Technical data	
Pitch (间距):	3.50mm(3.81mm)
Approval (认证):	UL, CE, Ex, SR, CQC
Rated voltage (电压):	300V 320V
Rated current (电流):	8A 10A
Wire range (线径):	30-14AWG 0.2-1.5mm ²
Screw (螺丝):	M2
料号 Part Number	
极数 (Poles)	型号 (Model)
02	TLPSW-011-02P(TLPSW-111-02P)
:	:
24	TLPSW-011-24P(TLPSW-111-24P)

TLPHS-112

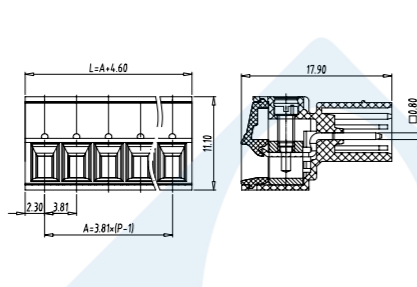

技术数据 Technical data	
Pitch (间距):	3.81mm
Approval (认证):	UL, CE, Ex, SR, CQC
Rated voltage (电压):	300V 320V
Rated current (电流):	8A 10A
Wire range (线径):	30-14AWG 0.2-1.5mm ²
Screw (螺丝):	M2
料号 Part Number	
极数 (Poles)	型号 (Model)
02	TLPHS-112-02P
:	:
24	TLPHS-112-24P

TLPHSW-112

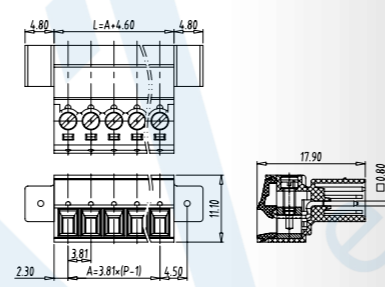

技术数据 Technical data	
Pitch (间距):	3.81mm
Approval (认证):	UL, CE, Ex, SR, CQC
Rated voltage (电压):	300V 320V
Rated current (电流):	8A 10A
Wire range (线径):	30-14AWG 0.2-1.5mm ²
Screw (螺丝):	M2
料号 Part Number	
极数 (Poles)	型号 (Model)
02	TLPHSW-112-02P
:	:
24	TLPHSW-112-24P

TLPSW-009V(TLPSW-109V)

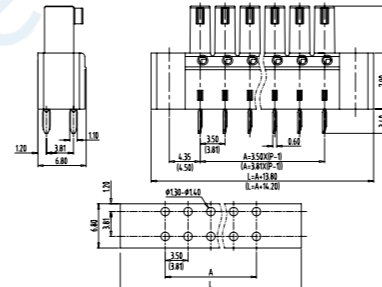
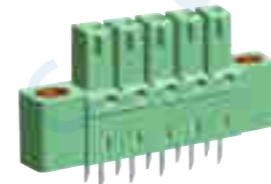

技术数据 Technical data	
Pitch (间距):	3.50mm(3.81mm)
Approval (认证):	UL, CE, Ex, SR, CQC VDE(Applying)
Rated voltage (电压):	300V 320V
Rated current (电流):	8A 10A
PCB hole Dia(PCB直径):	Φ 1.3mm-Φ 1.4mm
料号 Part Number	
极数 (Poles)	型号 (Model)
02	TLPSW-009V-02P(TLPSW-109V-02P)
:	:
24	TLPSW-009V-24P(TLPSW-109V-24P)

TLPSW-009R(TLPSW-109R)

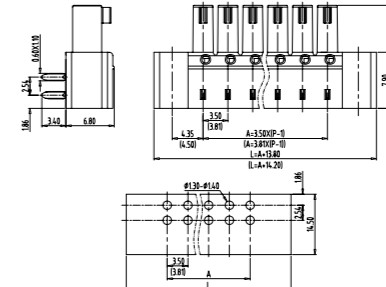
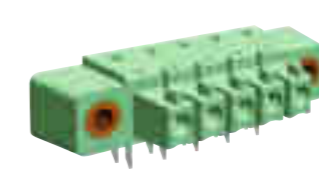

技术数据 Technical data	
Pitch (间距):	3.50mm(3.81mm)
Approval (认证):	UL, CE, Ex, SR, CQC VDE(Applying)
Rated voltage (电压):	300V 320V
Rated current (电流):	8A 10A
PCB hole Dia(PCB直径):	Φ 1.3mm-Φ 1.4mm
料号 Part Number	
极数 (Poles)	型号 (Model)
02	TLPSW-009R-02P(TLPSW-109R-02P)
:	:
24	TLPSW-009R-24P(TLPSW-109R-24P)

TLPSD-020

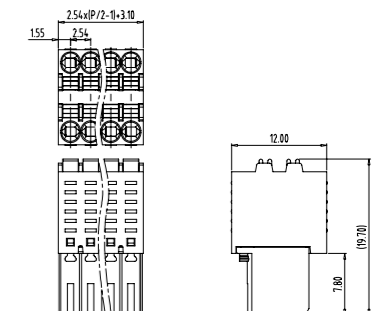

技术数据 Technical data	
Pitch (间距):	2.54mm
Approval (认证):	UL(Applying) VDE(Applying)
Rated voltage (电压):	150V 320V
Rated current (电流):	5A 6A
Wire range (线径):	30-20AWG 0.2-0.5mm ²
料号 Part Number	
极数 (Poles)	型号 (Model)
04	TLPSD-020-04P
:	:
48	TLPSD-020-48P

TLPSDW-020

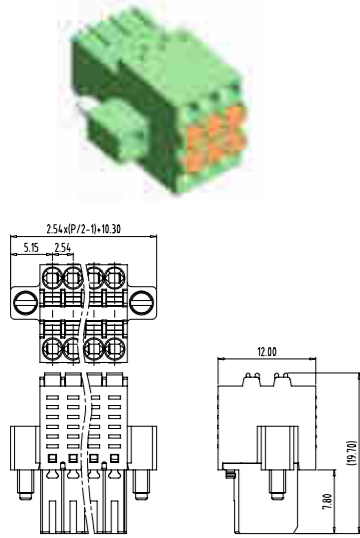

技术数据 Technical data	
Pitch (间距):	2.54mm
Approval (认证):	UL(Applying) VDE(Applying)
Rated voltage (电压):	150V 320V
Rated current (电流):	5A 6A
Wire range (线径):	30-20AWG 0.2-0.5mm ²
Screw (螺丝):	M2
料号 Part Number	
极数 (Poles)	型号 (Model)
04	TLPSDW-020-04P
:	:
48	TLPSDW-020-48P

TLPSDL-020

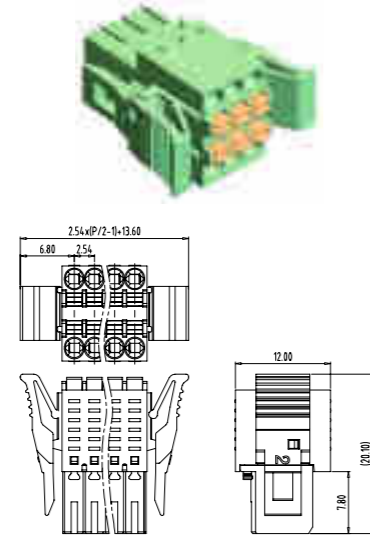

技术数据 Technical data	
Pitch (间距):	2.54mm
Approval (认证):	UL(Applying) VDE(Applying)
Rated voltage (电压):	150V 320V
Rated current (电流):	5A 6A
Wire range (线径):	30-20AWG 0.2-0.5mm ²
料号 Part Number	
极数 (Poles)	型号 (Model)
04	TLPSDL-020-04P
:	:
48	TLPSDL-020-48P

TLPSDR-020

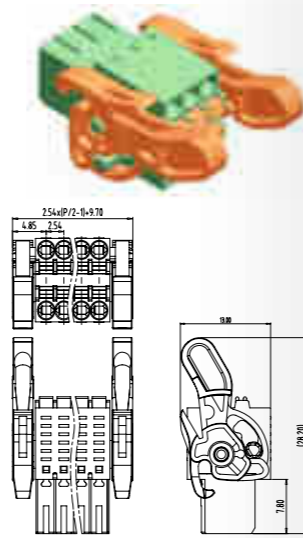

技术数据 Technical data	
Pitch (间距):	2.54mm
Approval (认证):	UL(Applying) VDE(Applying)
Rated voltage (电压):	150V 320V
Rated current (电流):	5A 6A
Wire range (线径):	30-20AWG 0.2-0.5mm ²
料号 Part Number	
极数 (Poles)	型号 (Model)
04	TLPSDR-020-04P
:	:
48	TLPSDR-020-48P

TLPSW-007(TLPSW-107)

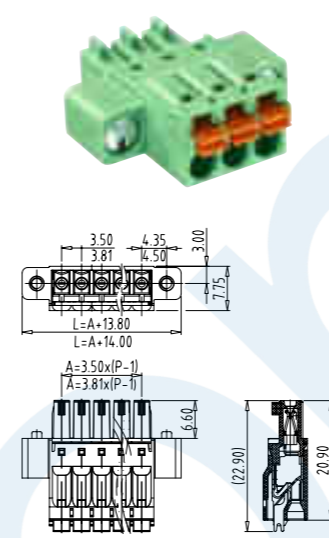

技术数据 Technical data	
Pitch (间距):	3.50mm(3.81mm)
Approval (认证):	UL (3.81Applying)
Rated voltage (电压):	300V 160V
Rated current (电流):	8A 10A
Wire range (线径):	28-16AWG 0.34-1.5mm ²
料号 Part Number	
极数 (Poles)	型号 (Model)
02	TLPSW-007-02P(TLPSW-107-02P)
:	:
24	TLPSW-007-24P(TLPSW-107-24P)

TLPSL-007(TLPSL-107)

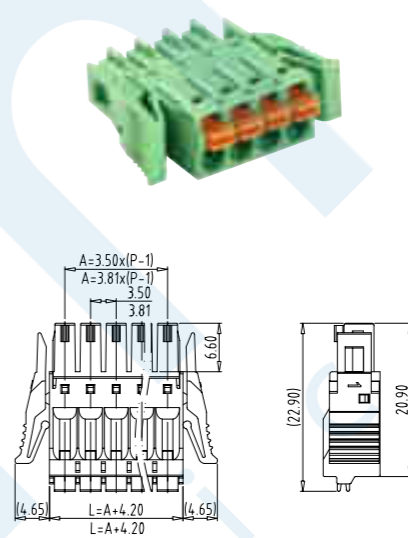

技术数据 Technical data	
Pitch (间距):	3.50mm(3.81mm)
Approval (认证):	UL (3.81Applying)
Rated voltage (电压):	300V 160V
Rated current (电流):	8A 10A
Wire range (线径):	28-16AWG 0.34-1.5mm ²
料号 Part Number	
极数 (Poles)	型号 (Model)
02	TLPSL-007-02P(TLPSL-107-02P)
:	:
24	TLPSL-007-24P(TLPSL-107-24P)

TLPSD-007

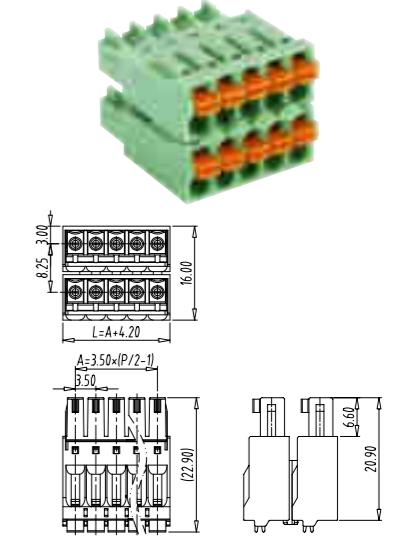

技术数据 Technical data	
Pitch (间距):	3.50mm
Approval (认证):	UL (3.81Applying)
Rated voltage (电压):	300V 160V
Rated current (电流):	8A 10A
Wire range (线径):	28-16AWG 0.34-1.5mm ²
料号 Part Number	
极数 (Poles)	型号 (Model)
04	TLPSD-007-04P
:	:
48	TLPSD-007-48P

TLPS-002V(TLPS-101V)

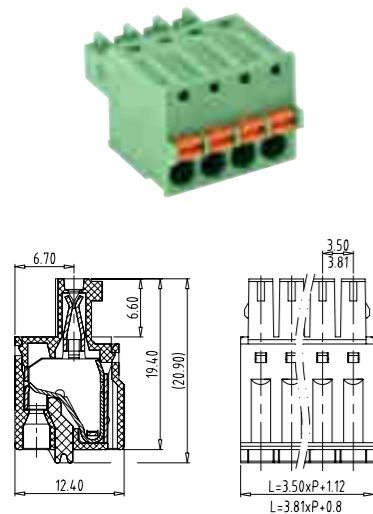

技术数据 Technical data	
Pitch (间距):	3.50mm(3.81mm)
Approval (认证):	UL (3.81Applying)
Rated voltage (电压):	300V
Rated current (电流):	8A
Wire range (线径):	28-16AWG
Screw (螺丝):	M2.5
料号 Part Number	
极数 (Poles)	型号 (Model)
02	TLPS-002V-02P(TLPS-101V-02P)
:	:
24	TLPS-002V-24P(TLPS-101V-24P)

TLPSW-002V(TLPSW-101V)

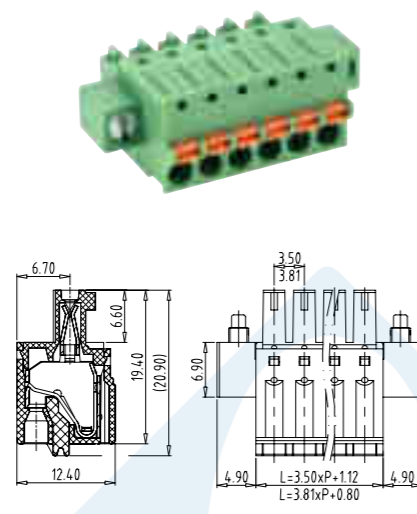

技术数据 Technical data	
Pitch (间距):	3.50mm(3.81mm)
Approval (认证):	UL (3.81Applying)
Rated voltage (电压):	300V
Rated current (电流):	8A
Wire range (线径):	28-16AWG
Screw (螺丝):	M2.5
料号 Part Number	
极数 (Poles)	型号 (Model)
02	TLPSW-002V-02P(TLPSW-101V-02P)
:	:
24	TLPSW-002V-24P(TLPSW-101V-24P)

TLPS-007(TLPS-107)

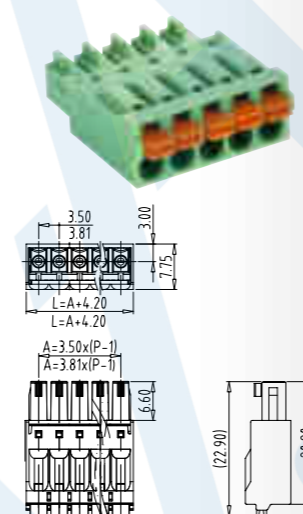

技术数据 Technical data	
Pitch (间距):	3.50mm(3.81mm)
Approval (认证):	UL (3.81Applying)
Rated voltage (电压):	300V 160V
Rated current (电流):	8A 10A
Wire range (线径):	28-16AWG 0.34-1.5mm ²
Screw (螺丝):	M2.5
料号 Part Number	
极数 (Poles)	型号 (Model)
02	TLPS-007-02P(TLPS-107-02P)
:	:
24	TLPS-007-24P(TLPS-107-24P)

TLPSDW-007

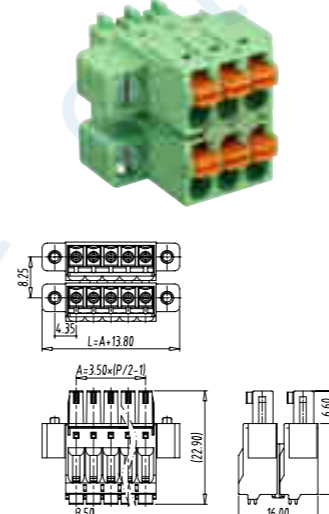

技术数据 Technical data	
Pitch (间距):	3.50mm
Approval (认证):	UL (3.81Applying)
Rated voltage (电压):	300V 160V
Rated current (电流):	8A 10A
Wire range (线径):	28-16AWG 0.34-1.5mm ²
Screw (螺丝):	M2.5
料号 Part Number	
极数 (Poles)	型号 (Model)
04	TLPSDW-007-04P
:	:
48	TLPSDW-007-48P

TLPSDL-007

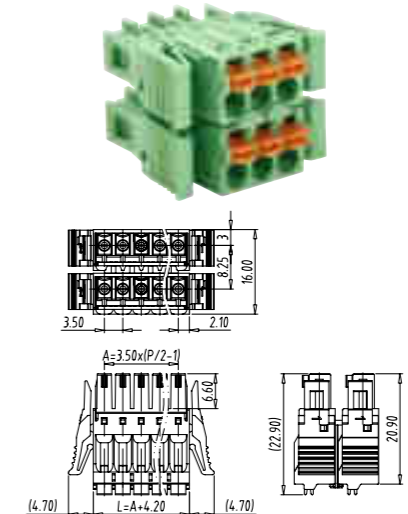

技术数据 Technical data	
Pitch (间距):	3.50mm
Approval (认证):	UL (3.81Applying)
Rated voltage (电压):	300V 160V
Rated current (电流):	8A 10A
Wire range (线径):	28-16AWG 0.34-1.5mm ²
料号 Part Number	
极数 (Poles)	型号 (Model)
04	TLPSDL-007-04P
:	:
48	TLPSDL-007-48P

TLPSD-010

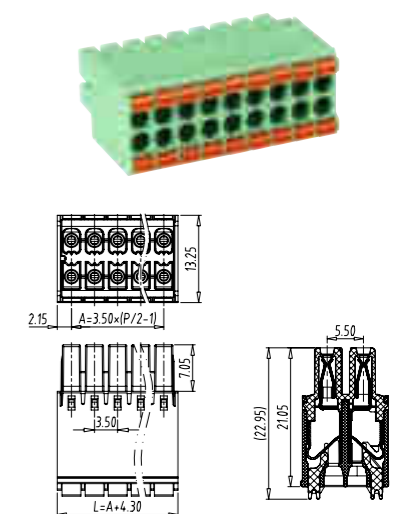

技术数据 Technical data	
Pitch (间距):	3.50mm
Approval (认证):	UL (3.81Applying)
Rated voltage (电压):	300V 160V
Rated current (电流):	8A 10A
Wire range (线径):	28-16AWG 0.34-1.5mm ²
料号 Part Number	
极数 (Poles)	型号 (Model)
04	TLPSD-010-04P
:	:
48	TLPSD-010-48P

TLPSDW-010

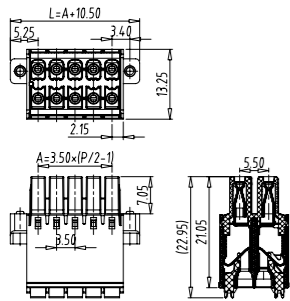
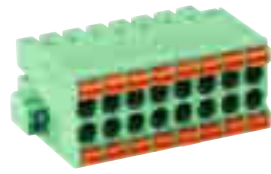

技术数据 Technical data	
Pitch (间距):	3.50mm
Approval (认证):	UL, CE, Ex
Rated voltage (电压):	300V 160V
Rated current (电流):	8A 10A
Wire range (线径):	28-16AWG 0.34-1.5mm ²
Screw (螺丝):	M2
料号 Part Number	
极数 (Poles)	型号 (Model)
04	TLPSDW-010-04P
:	:
48	TLPSDW-010-48P

TLPSDL-010

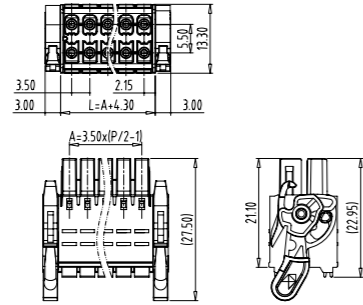

技术数据 Technical data	
Pitch (间距):	3.50mm
Approval (认证):	UL, CE, Ex
Rated voltage (电压):	300V 160V
Rated current (电流):	8A 10A
Wire range (线径):	28-16AWG 0.34-1.5mm ²
料号 Part Number	
极数 (Poles)	型号 (Model)
04	TLPSDL-010-04P
:	:
48	TLPSDL-010-48P

TLPS-200V(TLPS-300V)

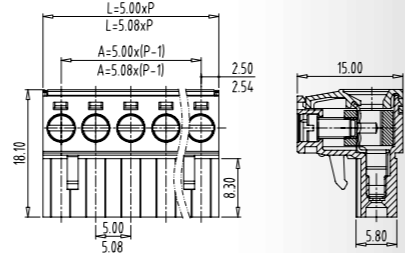

技术数据 Technical data	
Pitch (间距):	5.00mm(5.08mm)
Approval (认证):	UL, CE, Ex
Rated voltage (电压):	300V 320V
Rated current (电流):	16A 20A
Wire range (线径):	30-12AWG 0.2-4mm ²
Screw (螺丝):	M3
料号 Part Number	
极数 (Poles)	型号 (Model)
02	TLPS-200V-02P(TLPS-300V-02P)
:	:
24	TLPS-200V-24P(TLPS-300V-24P)

TLPS-200RL(TLPS-300RL)

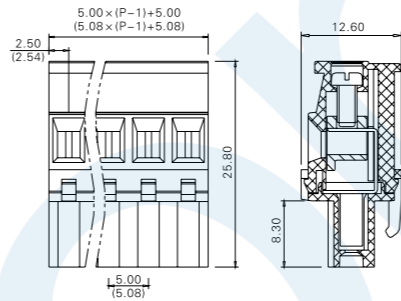

技术数据 Technical data	
Pitch (间距):	5.00mm(5.08mm)
Approval (认证):	UL, CE, Ex
Rated voltage (电压):	300V 630V
Rated current (电流):	16A 15A(16A)
Wire range (线径):	30-12AWG 0.2-4mm ²
Screw (螺丝):	M3
料号 Part Number	
极数 (Poles)	型号 (Model)
02	TLPS-200RL-02P(TLPS-300RL-02P)
:	:
24	TLPS-200RL-24P(TLPS-300RL-24P)

TLPSW-200RL(TLPSW-300RL)

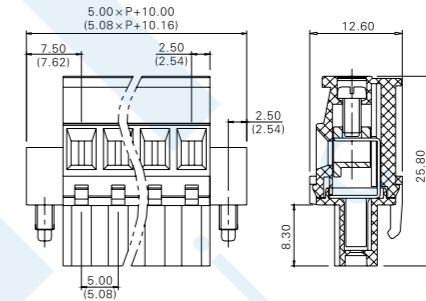

技术数据 Technical data	
Pitch (间距):	5.00mm(5.08mm)
Approval (认证):	UL, CE, Ex
Rated voltage (电压):	300V 630V
Rated current (电流):	16A 15A(16A)
Wire range (线径):	30-12AWG 0.2-4mm ²
Screw (螺丝):	M3
料号 Part Number	
极数 (Poles)	型号 (Model)
02	TLPSW-200RL-02P(TLPSW-300RL-02P)
:	:
24	TLPSW-200RL-24P(TLPSW-300RL-24P)

TLPS-207

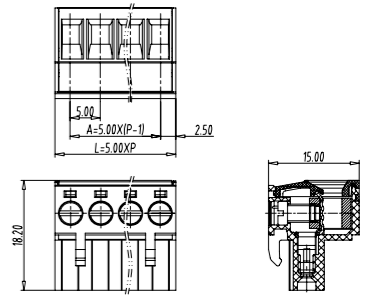

技术数据 Technical data	
Pitch (间距):	5.00mm
Approval (认证):	UL, CE, Ex
Rated voltage (电压):	300V 630V
Rated current (电流):	16A 20A
Wire range (线径):	12-30AWG 0.2-4mm ²
Screw (螺丝):	M3
料号 Part Number	
极数 (Poles)	型号 (Model)
02	TLPS-207-02P
:	:
24	TLPS-207-24P

TLPSW-200V(TLPSW-300V)

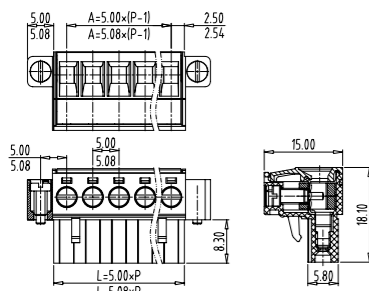

技术数据 Technical data	
Pitch (间距):	5.00mm(5.08mm)
Approval (认证):	UL, CE, Ex
Rated voltage (电压):	300V 320V
Rated current (电流):	16A 20A
Wire range (线径):	30-12AWG 0.2-4mm ²
Screw (螺丝):	M3
料号 Part Number	
极数 (Poles)	型号 (Model)
02	TLPSW-200V-02P(TLPSW-300V-02P)
:	:
24	TLPSW-200V-24P(TLPSW-300V-24P)

TLPS-200R(TLPS-300R)

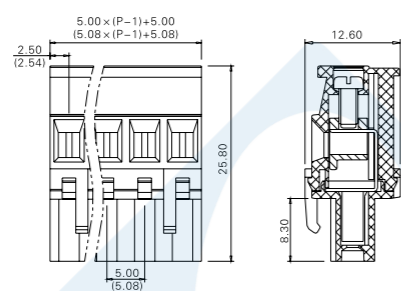

技术数据 Technical data	
Pitch (间距):	5.00mm(5.08mm)
Approval (认证):	UL, CE, Ex
Rated voltage (电压):	300V 320V
Rated current (电流):	16A 20A
Wire range (线径):	30-12AWG 0.2-4mm ²
Screw (螺丝):	M3
料号 Part Number	
极数 (Poles)	型号 (Model)
02	TLPS-200R-02P(TLPS-300R-02P)
:	:
24	TLPS-200R-24P(TLPS-300R-24P)

TLPSW-200R(TLPSW-300R)

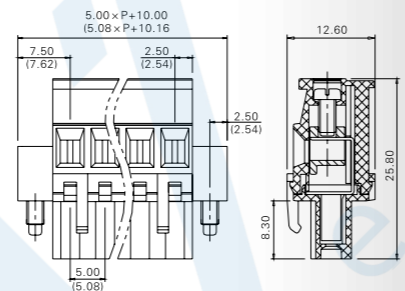

技术数据 Technical data	
Pitch (间距):	5.00mm(5.08mm)
Approval (认证):	UL, CE, Ex
Rated voltage (电压):	300V 320V
Rated current (电流):	16A 20A
Wire range (线径):	30-12AWG 0.2-4mm ²
Screw (螺丝):	M3
料号 Part Number	
极数 (Poles)	型号 (Model)
02	TLPSW-200R-02P(TLPSW-300R-02P)
:	:
24	TLPSW-200R-24P(TLPSW-300R-24P)

TLPSW-207

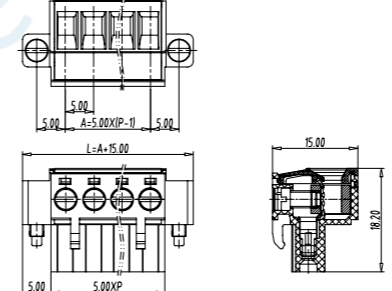

技术数据 Technical data	
Pitch (间距):	5.00mm
Approval (认证):	UL, CE, Ex
Rated voltage (电压):	300V 630V
Rated current (电流):	16A 20A
Wire range (线径):	12-30AWG 0.2-4mm ²
Screw (螺丝):	M3
料号 Part Number	
极数 (Poles)	型号 (Model)
02	TLPSW-207-02P
:	:
24	TLPSW-207-24P

TLPS-215(TLPS-301)

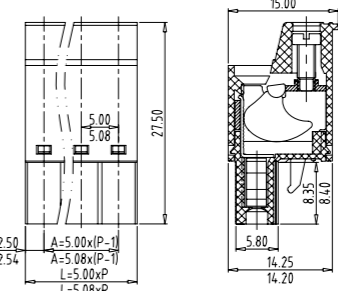

技术数据 Technical data	
Pitch (间距):	5.00mm(5.08mm)
Approval (认证):	UL, CE, Ex (5.00mm Applying)
Rated voltage (电压):	300V 320V
Rated current (电流):	16A 20A
Wire range (线径):	30-12AWG 0.34-2.5mm ²
Screw (螺丝):	M2.5
料号 Part Number	
极数 (Poles)	型号 (Model)
02	TLPS-215-02P(TLPS-301-02P)
:	:
24	TLPS-215-24P(TLPS-301-24P)

TLPSW-215(TLPSW-301)

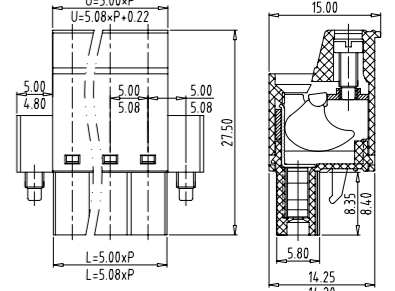
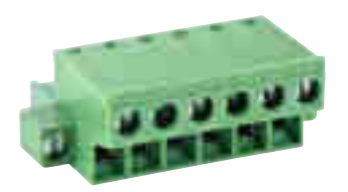

技术数据 Technical data	
Pitch (间距):	5.00mm(5.08mm)
Approval (认证):	UL, CE, Ex (5.00mm Applying)
Rated voltage (电压):	300V 320V
Rated current (电流):	16A 20A
Wire range (线径):	30-12AWG 0.34-2.5mm ²
Screw (螺丝):	M2.5
料号 Part Number	
极数 (Poles)	型号 (Model)
02	TLPSW-215-02P(TLPSW-301-02P)
:	:
24	TLPSW-215-24P(TLPSW-301-24P)

TLPS-225

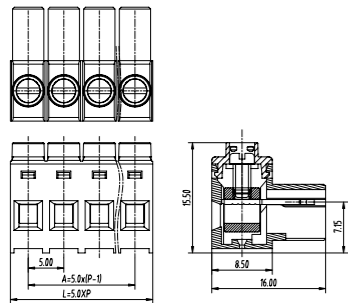

技术数据 Technical data	
Pitch (间距):	5.00mm
Approval (认证):	VDE(Applying)
Rated voltage (电压):	300V 630V
Rated current (电流):	15A
Wire range (线径):	28-12AWG
Screw (螺丝):	M2.5
料号 Part Number	
极数 (Poles)	型号 (Model)
02	TLPS-225-02P
:	:
24	TLPS-225-24P

TLPS-313V

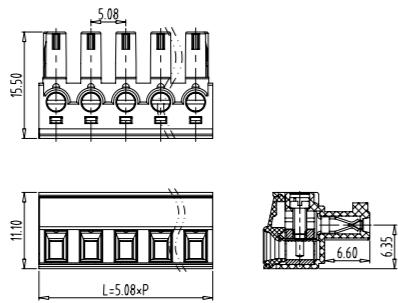

技术数据 Technical data	
Pitch (间距):	5.08mm
Approval (认证):	VDE(Applying)
Rated voltage (电压):	300V 630V
Rated current (电流):	11A 13A
Wire range (线径):	30-14AWG 0.2-1.5mm ²
Screw (螺丝):	M2
料号 Part Number	
极数 (Poles)	型号 (Model)
02	TLPS-313V-02P
:	:
24	TLPS-313V-24P

TLPSW-313V

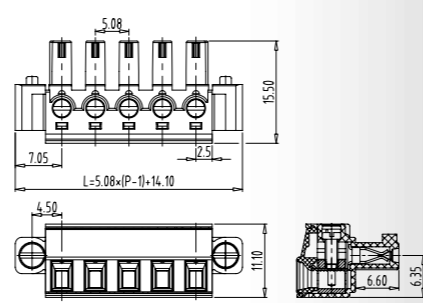

技术数据 Technical data	
Pitch (间距):	5.08mm
Approval (认证):	VDE(Applying)
Rated voltage (电压):	300V 630V
Rated current (电流):	11A 13A
Wire range (线径):	30-14AWG 0.2-1.5mm ²
Screw (螺丝):	M2
料号 Part Number	
极数 (Poles)	型号 (Model)
02	TLPS-313V-02P
:	:
24	TLPS-313V-24P

TLPSW-312V

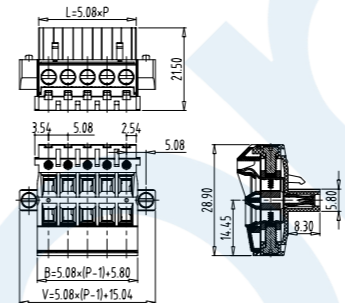
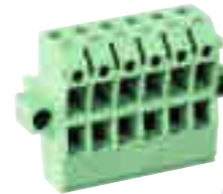

技术数据 Technical data	
Pitch (间距):	5.08mm
Approval (认证):	VDE(Applying)
Rated voltage (电压):	300V 630V
Rated current (电流):	16A 20A
Wire range (线径):	30-12AWG 0.2-4mm ²
Screw (螺丝):	M3
料号 Part Number	
极数 (Poles)	型号 (Model)
02	TLPSW-312V-02P
:	:
24	TLPSW-312V-24P

TLPHS-304

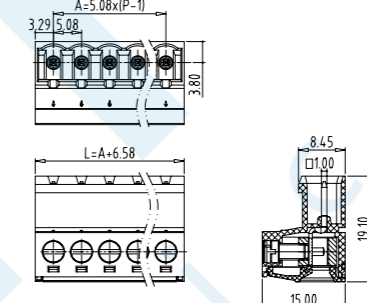

技术数据 Technical data	
Pitch (间距):	5.08mm
Approval (认证):	VDE(Applying)
Rated voltage (电压):	300V 630V
Rated current (电流):	20A 20A
Wire range (线径):	30-12AWG 0.2-2.5mm ² sol / str 4mm ² sol
Screw (螺丝):	M3
料号 Part Number	
极数 (Poles)	型号 (Model)
02	TLPHS-304-02P
:	:
24	TLPHS-304-24P

TLPHSW-304

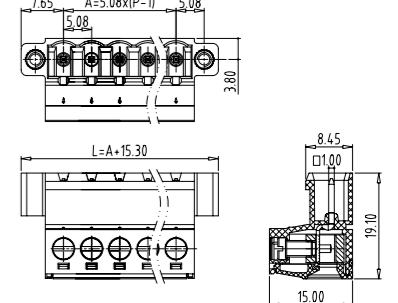
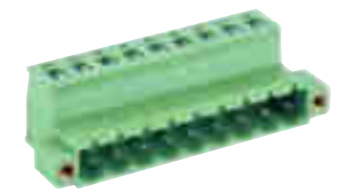

技术数据 Technical data	
Pitch (间距):	5.08mm
Approval (认证):	VDE(Applying)
Rated voltage (电压):	300V 630V
Rated current (电流):	20A 20A
Wire range (线径):	30-12AWG 0.2-2.5mm ² sol / str 4mm ² sol
Screw (螺丝):	M3
料号 Part Number	
极数 (Poles)	型号 (Model)
02	TLPHSW-304-02P
:	:
24	TLPHSW-304-24P

TLPS-308

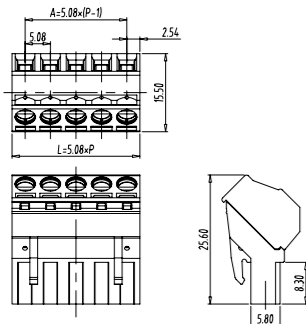

技术数据 Technical data	
Pitch (间距):	5.08mm
Approval (认证):	VDE(Applying)
Rated voltage (电压):	300V 630V
Rated current (电流):	16A 18A
Wire range (线径):	30-12AWG 0.2-4mm ²
Screw (螺丝):	M3.0
料号 Part Number	
极数 (Poles)	型号 (Model)
02	TLPS-308-02P
:	:
24	TLPS-308-24P

TLPSW-308

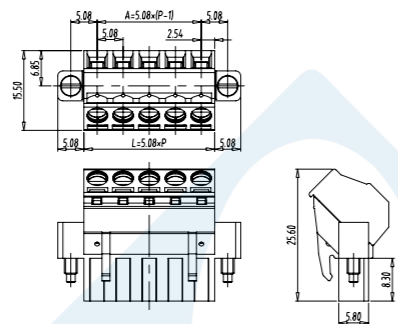
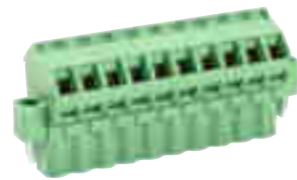

技术数据 Technical data	
Pitch (间距):	5.08mm
Approval (认证):	VDE(Applying)
Rated voltage (电压):	300V 630V
Rated current (电流):	16A 18A
Wire range (线径):	30-12AWG 0.2-4mm ²
Screw (螺丝):	M3.0
料号 Part Number	
极数 (Poles)	型号 (Model)
02	TLPSW-308-02P
:	:
24	TLPSW-308-24P

TLPS-312V

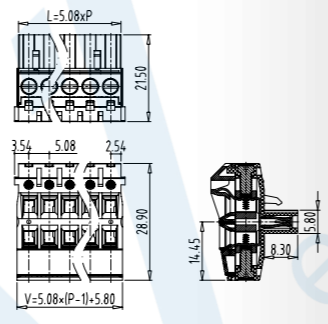

技术数据 Technical data	
Pitch (间距):	5.08mm
Approval (认证):	VDE(Applying)
Rated voltage (电压):	300V 630V
Rated current (电流):	16A 20A
Wire range (线径):	30-12AWG 0.2-4mm ²
Screw (螺丝):	M3
料号 Part Number	
极数 (Poles)	型号 (Model)
02	TLPS-312V-02P
:	:
24	TLPS-312V-24P

TLPHSWA-304

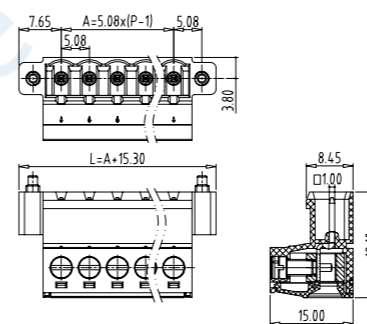

技术数据 Technical data	
Pitch (间距):	5.08mm
Approval (认证):	VDE(Applying)
Rated voltage (电压):	300V 630V
Rated current (电流):	20A 20A
Wire range (线径):	30-12AWG 0.2-2.5mm ² sol / str 4mm ² sol
Screw (螺丝):	M3
料号 Part Number	
极数 (Poles)	型号 (Model)
02	TLPHSWA-304-02P
:	:
24	TLPHSWA-304-24P

TLPS-205V(TLPS-305V)

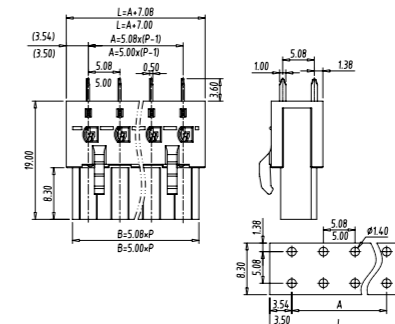

技术数据 Technical data	
Pitch (间距):	5.00mm(5.08mm)
Approval (认证):	VDE(Applying)
Rated voltage (电压):	300V 630V
Rated current (电流):	16A 20A
PCB hole Dia(PCB 直径):	Φ1.4mm
料号 Part Number	
极数 (Poles)	型号 (Model)
02	TLPS-205V-02P(TLPS-305V-02P)
:	:
24	TLPS-205V-24P(TLPS-305V-24P)

TLPSW-205V(TLPSW-305V)

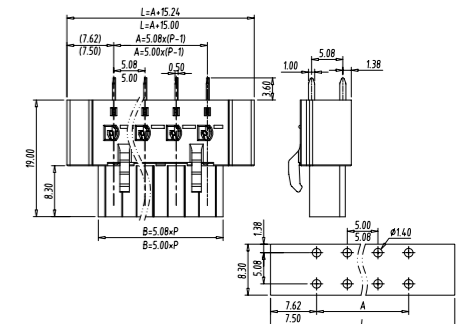
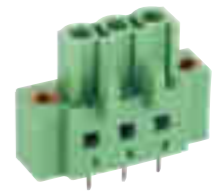

技术数据 Technical data	
Pitch (间距):	5.00mm(5.08mm)
Approval (认证):	VDE(Applying)
Rated voltage (电压):	300V 630V
Rated current (电流):	16A 20A
PCB hole Dia(PCB 直径):	Φ1.4mm
料号 Part Number	
极数 (Poles)	型号 (Model)
02	TLPSW-205V-02P(TLPSW-305V-02P)
:	:
24	TLPSW-205V-24P(TLPSW-305V-24P)

TLPS-205R(TLPS-305R)

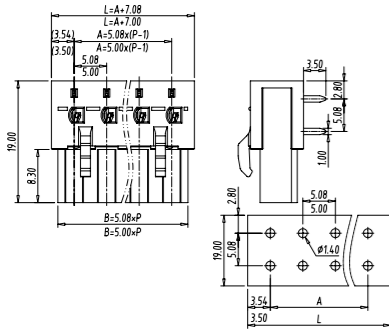

技术数据 Technical data	
Pitch (间距):	5.00mm(5.08mm)
Approval (认证):	VDE(Applying)
Rated voltage (电压):	300V 630V
Rated current (电流):	16A 20A
PCB hole Dia(PCB 直径):	Φ 1.4mm

料号 Part Number	
极数 (Poles)	型号 (Model)
02	TLPS-205R-02P(TLPS-305R-02P)
:	:
24	TLPS-205R-24P(TLPS-305R-24P)

TLPSW-205R(TLPSW-305R)

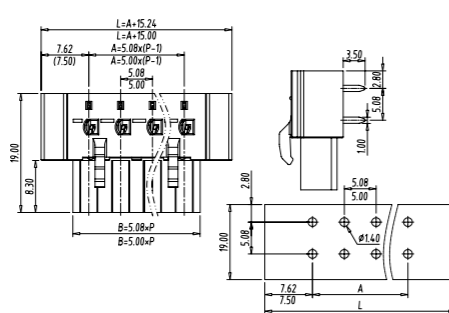

技术数据 Technical data	
Pitch (间距):	5.00mm(5.08mm)
Approval (认证):	VDE(Applying)
Rated voltage (电压):	300V 630V
Rated current (电流):	16A 20A
PCB hole Dia(PCB 直径):	Φ 1.4mm

料号 Part Number	
极数 (Poles)	型号 (Model)
02	TLPSW-205R-02P(TLPSW-305R-02P)
:	:
24	TLPSW-205R-24P(TLPSW-305R-24P)

TLPS-201V(TLPS-302V)

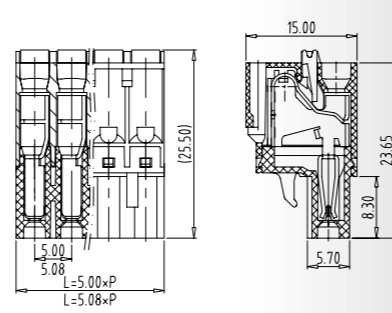

技术数据 Technical data	
Pitch (间距):	5.00mm(5.08mm)
Approval (认证):	
Rated voltage (电压):	300V 320V
Rated current (电流):	12A 15A
Wire range (线径):	24-12AWG 0.34-2.5mm ²

料号 Part Number	
极数 (Poles)	型号 (Model)
02	TLPS-201V-02P(TLPS-302V-02P)
:	:
24	TLPS-201V-24P(TLPS-302V-24P)

TLPS-201R(TLPS-302R)

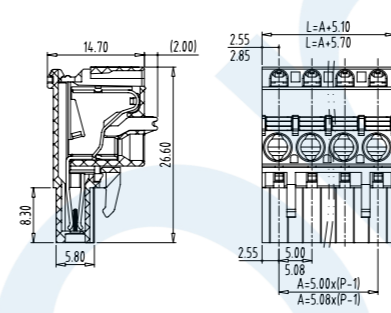
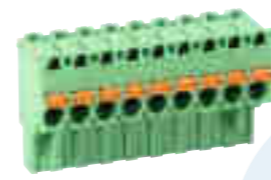

技术数据 Technical data	
Pitch (间距):	5.00mm(5.08mm)
Approval (认证):	
Rated voltage (电压):	300V 630V
Rated current (电流):	12A 15A
Wire range (线径):	26-12AWG 0.2-2.5mm ²

料号 Part Number	
极数 (Poles)	型号 (Model)
02	TLPS-201R-02P(TLPS-302R-02P)
:	:
24	TLPS-201R-24P(TLPS-302R-24P)

TLPSW-201R(TLPSW-302R)

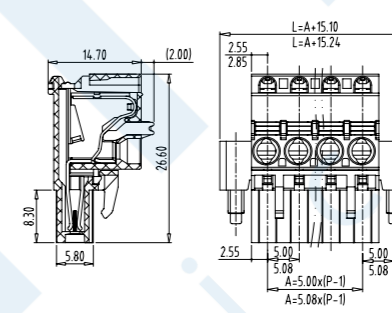

技术数据 Technical data	
Pitch (间距):	5.00mm(5.08mm)
Approval (认证):	
Rated voltage (电压):	300V 630V
Rated current (电流):	12A 15A
Wire range (线径):	26-12AWG 0.2-2.5mm ²
Screw (螺丝):	M2.5

料号 Part Number	
极数 (Poles)	型号 (Model)
02	TLPSW-201R-02P(TLPSW-302R-02P)
:	:
24	TLPSW-201R-24P(TLPSW-302R-24P)

TLPS-201RL(TLPS-302RL)

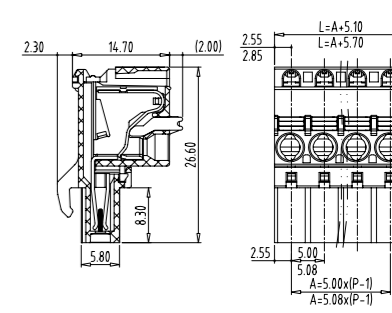
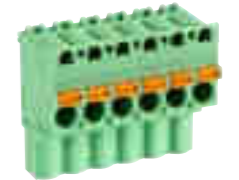

技术数据 Technical data	
Pitch (间距):	5.00mm(5.08mm)
Approval (认证):	
Rated voltage (电压):	300V 630V
Rated current (电流):	12A 15A
Wire range (线径):	26-12AWG 0.2-2.5mm ²

料号 Part Number	
极数 (Poles)	型号 (Model)
02	TLPS-201RL-02P(TLPS-302RL-02P)
:	:
24	TLPS-201RL-24P(TLPS-302RL-24P)

TLPSW-201V(TLPSW-302V)

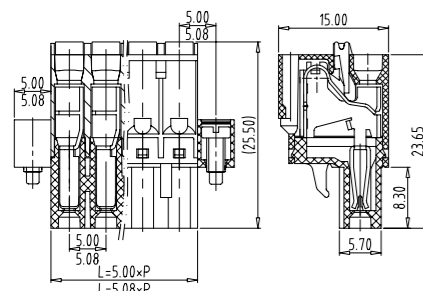
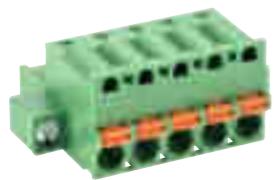

技术数据 Technical data	
Pitch (间距):	5.00mm(5.08mm)
Approval (认证):	
Rated voltage (电压):	300V 320V
Rated current (电流):	12A 15A
Wire range (线径):	24-12AWG 0.34-2.5mm ²
Screw (螺丝):	M2.5

料号 Part Number	
极数 (Poles)	型号 (Model)
02	TLPSW-201V-02P(TLPSW-302V-02P)
:	:
24	TLPSW-201V-24P(TLPSW-302V-24P)

TLPS-214V

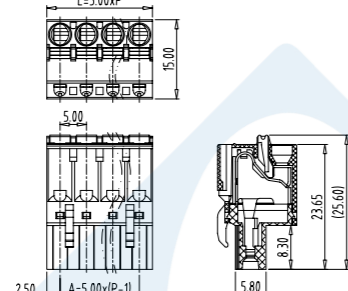
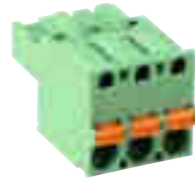

技术数据 Technical data	
Pitch (间距):	5.00mm
Approval (认证):	
Rated voltage (电压):	300V 630V
Rated current (电流):	12A 15A
Wire range (线径):	26-12AWG 0.2-2.5mm ²

料号 Part Number	
极数 (Poles)	型号 (Model)
02	TLPS-214V-02P
:	:
24	TLPS-214V-24P

TLPSW-214V

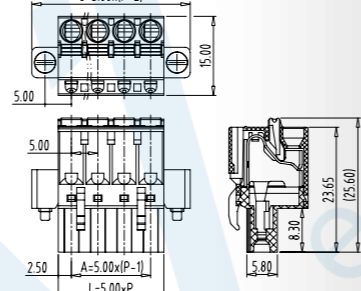

技术数据 Technical data	
Pitch (间距):	5.00mm
Approval (认证):	
Rated voltage (电压):	300V 630V
Rated current (电流):	12A 15A
Wire range (线径):	26-12AWG 0.2-2.5mm ²

料号 Part Number	
极数 (Poles)	型号 (Model)
02	TLPSW-214V-02P
:	:
24	TLPSW-214V-24P

TLPSW-201RL(TLPSW-302RL)

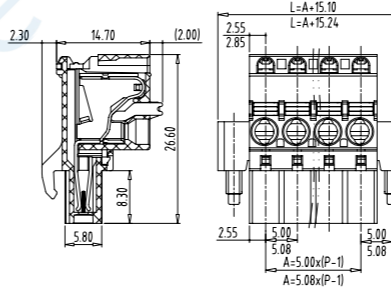

技术数据 Technical data	
Pitch (间距):	5.00mm(5.08mm)
Approval (认证):	
Rated voltage (电压):	300V 630V
Rated current (电流):	12A 15A
Wire range (线径):	26-12AWG 0.2-2.5mm ²
Screw (螺丝):	M2.5

料号 Part Number	
极数 (Poles)	型号 (Model)
02	TLPSW-201RL-02P(TLPSW-302RL-02P)
:	:
24	TLPSW-201RL-24P(TLPSW-302RL-24P)

TLPS-309

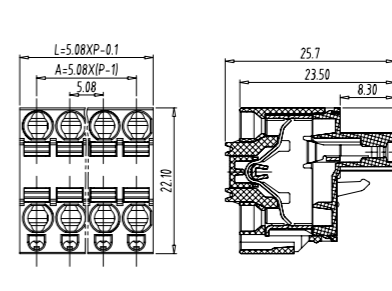

技术数据 Technical data	
Pitch (间距):	5.08mm
Approval (认证):	
Rated voltage (电压):	300V 320V
Rated current (电流):	12A 15A
Wire range (线径):	26-12AWG 0.34-2.5mm ²

料号 Part Number	
极数 (Poles)	型号 (Model)
02	TLPS-309-02P
:	:
24	TLPS-309-24P

TLPSW-309

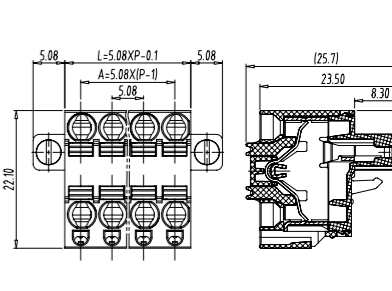

技术数据 Technical data	
Pitch (间距):	5.08mm
Approval (认证):	
Rated voltage (电压):	300V 320V
Rated current (电流):	12A 15A
Wire range (线径):	26-12AWG 0.34-2.5mm ²
Screw (螺丝):	M2.5

料号 Part Number	
极数 (Poles)	型号 (Model)
02	TLPSW-309-02P
:	:
24	TLPSW-309-24P

TLPS-400V(TLPS-500V)

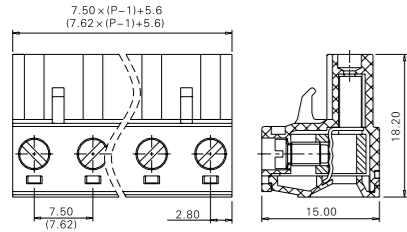

技术数据 Technical data	
Pitch (间距):	7.50mm(7.62mm)
Approval (认证):	UL, VDE
Rated voltage (电压):	300V 630V
Rated current (电流):	16A 20A
Wire range (线径):	30-12AWG 0.2-4mm ²
Screw (螺丝):	M3
料号 Part Number	
极数 (Poles)	型号 (Model)
02	TLPS-400V-02P(TLPS-500V-02P)
:	:
12	TLPS-400V-12P(TLPS-500V-12P)

TLPSW-400V(TLPSW-500V)

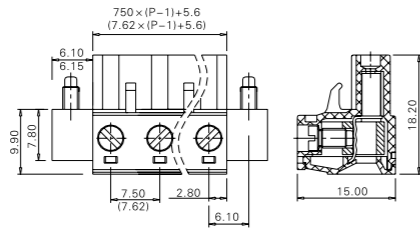
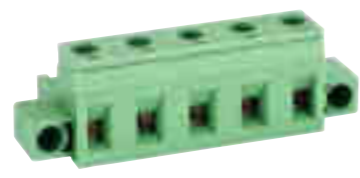

技术数据 Technical data	
Pitch (间距):	7.50mm(7.62mm)
Approval (认证):	UL, VDE
Rated voltage (电压):	300V 630V
Rated current (电流):	16A 20A
Wire range (线径):	30-12AWG 0.2-4mm ²
Screw (螺丝):	M3
料号 Part Number	
极数 (Poles)	型号 (Model)
02	TLPSW-400V-02P(TLPSW-500V-02P)
:	:
12	TLPSW-400V-12P(TLPSW-500V-12P)

TLPS-400R(TLPS-500R)

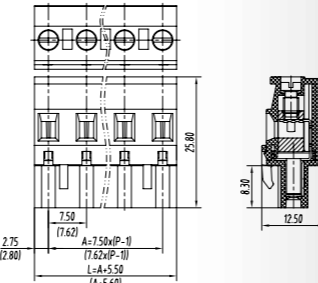

技术数据 Technical data	
Pitch (间距):	7.50mm(7.62mm)
Approval (认证):	UL, VDE
Rated voltage (电压):	300V 630V
Rated current (电流):	16A 20A
Wire range (线径):	30-12AWG 0.2-4mm ²
Screw (螺丝):	M3.0
料号 Part Number	
极数 (Poles)	型号 (Model)
02	TLPS-400R-02P(TLPS-500R-02P)
:	:
12	TLPS-400R-12P(TLPS-500R-12P)

TLPS-505V

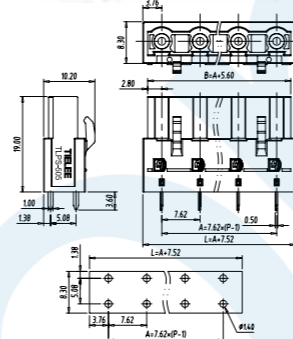
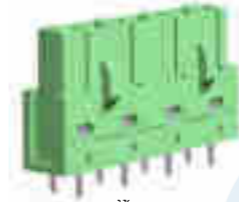

技术数据 Technical data	
Pitch (间距):	7.62mm
Approval (认证):	UL(Applying) VDE(Applying)
Rated voltage (电压):	300V 1000V
Rated current (电流):	16A 20A
PCB hole Dia(PCB直径):	Φ 1.4mm
料号 Part Number	
极数 (Poles)	型号 (Model)
02	TLPS-505V-02P
:	:
16	TLPS-505V-16P

TLPSW-505V

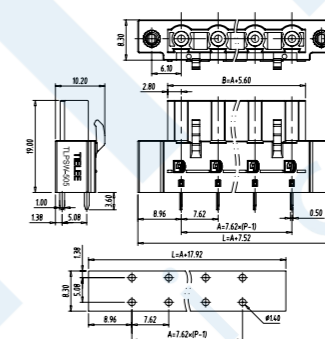

技术数据 Technical data	
Pitch (间距):	7.62mm
Approval (认证):	UL(Applying) VDE(Applying)
Rated voltage (电压):	300V 1000V
Rated current (电流):	16A 20A
PCB hole Dia(PCB直径):	Φ 1.4mm
料号 Part Number	
极数 (Poles)	型号 (Model)
02	TLPSW-505V-02P
:	:
16	TLPSW-505V-16P

TLPS-505R

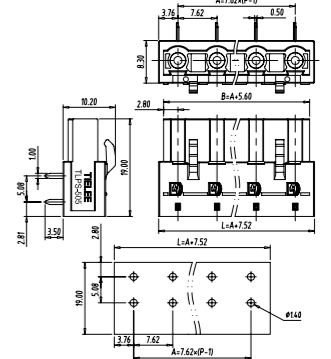

技术数据 Technical data	
Pitch (间距):	7.62mm
Approval (认证):	UL(Applying) VDE(Applying)
Rated voltage (电压):	300V 1000V
Rated current (电流):	16A 20A
PCB hole Dia(PCB直径):	Φ 1.4mm
料号 Part Number	
极数 (Poles)	型号 (Model)
02	TLPS-505R-02P
:	:
16	TLPS-505R-16P

TLPSW-400R(TLPSW-500R)

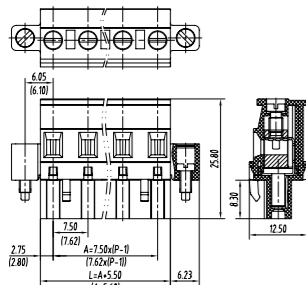

技术数据 Technical data	
Pitch (间距):	7.50mm(7.62mm)
Approval (认证):	UL, VDE
Rated voltage (电压):	300V 630V
Rated current (电流):	16A 20A
Wire range (线径):	30-12AWG 0.2-4mm ²
Screw (螺丝):	M3.0
料号 Part Number	
极数 (Poles)	型号 (Model)
02	TLPSW-400R-02P(TLPSW-500R-02P)
:	:
12	TLPSW-400R-12P(TLPSW-500R-12P)

TLPS-400RL(TLPS-500RL)

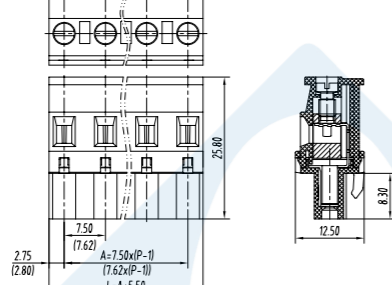

技术数据 Technical data	
Pitch (间距):	7.50mm(7.62mm)
Approval (认证):	UL, VDE(Applying)
Rated voltage(电压):	300V 630V
Rated current (电流):	16A 20A
Wire range(线径):	30-12AWG 0.2-4mm ²
Screw(螺丝):	M3.0
料号 Part Number	
极数 (Poles)	型号 (Model)
02	TLPS-400RL-02P(TLPS-500RL-02P)
:	:
12	TLPS-400RL-12P(TLPS-500RL-12P)

TLPSW-400RL(TLPSW-500RL)

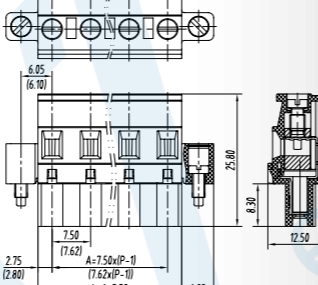

技术数据 Technical data	
Pitch(间距):	7.50mm(7.62mm)
Approval(认证):	UL, VDE(Applying)
Rated voltage(电压):	300V 630V
Rated current(电流):	16A 20A
Wire range(线径):	30-12AWG 0.2-4mm ²
Screw(螺丝):	M3.0
料号 Part Number	
极数 (Poles)	型号 (Model)
02	TLPSW-400RL-02P(TLPSW-500RL-02P)
:	:
12	TLPSW-400RL-12P(TLPSW-500RL-12P)

TLPSW-505R

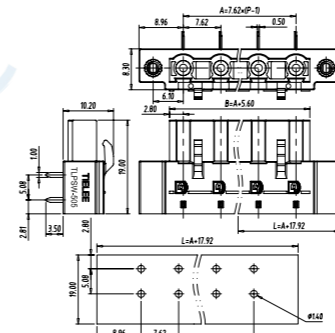

技术数据 Technical data	
Pitch (间距):	7.62mm
Approval (认证):	UL(Applying) VDE(Applying)
Rated voltage (电压):	300V 1000V
Rated current (电流):	16A 20A
PCB hole Dia(PCB直径):	Φ 1.4mm
料号 Part Number	
极数 (Poles)	型号 (Model)
02	TLPSW-505R-02P
:	:
16	TLPSW-505R-16P

TLPS-501

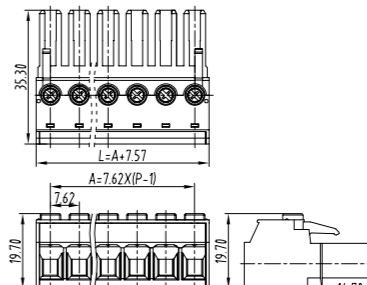

技术数据 Technical data	
Pitch (间距):	7.62mm
Approval (认证):	UL, VDE
Rated voltage (电压):	600V 1000V
Rated current (电流):	41A 41A
Wire range (线径):	8-24AWG 0.34-6mm ²
Screw (螺丝):	M3
料号 Part Number	
极数 (Poles)	型号 (Model)
02	TLPS-501-02P
:	:
16	TLPS-501-12P

TLPSW-501

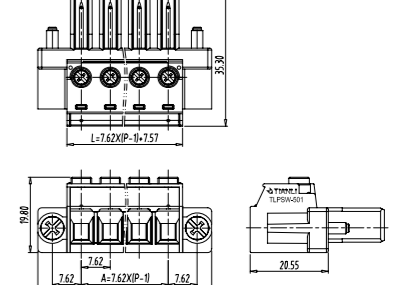

技术数据 Technical data	
Pitch (间距):	7.62mm
Approval (认证):	UL, VDE
Rated voltage (电压):	600V 1000V
Rated current (电流):	41A 41A
Wire range (线径):	24-8AWG 0.34-6mm ²
Screw (螺丝):	M3
料号 Part Number	
极数 (Poles)	型号 (Model)
02	TLPSW-501-02P
:	:
14	TLPSW-501-14P

TLPS-502

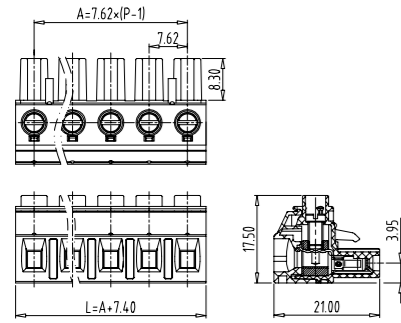

技术数据 Technical data	
Pitch (间距):	7.62mm
Approval (认证):	UL VDE(Applying)
Rated voltage (电压):	600V 1000V
Rated current (电流):	20A 20A
Wire range (线径):	30-12AWG 0.2-4mm ²
Screw (螺丝):	M3
料号 Part Number	
极数 (Poles)	型号 (Model)
02	TLPS-502-02P
:	:
12	TLPS-502-12P

TLPS-516V

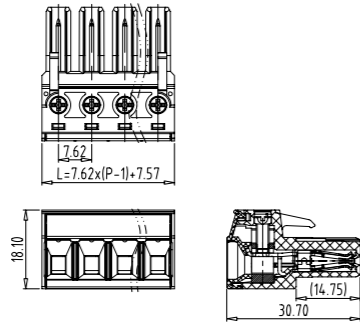
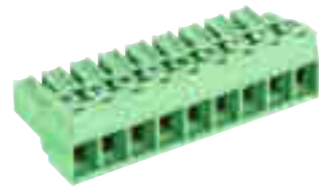

技术数据 Technical data	
Pitch (间距):	7.62mm
Approval (认证):	UL VDE
Rated voltage (电压):	300V 1000V
Rated current (电流):	30A 32A
Wire range (线径):	30-10AWG 0.2-4mm ²
Screw (螺丝):	M3
料号 Part Number	
极数 (Poles)	型号 (Model)
02	TLPS-516V-02P
:	:
16	TLPS-516V-16P

TLPSW-516V

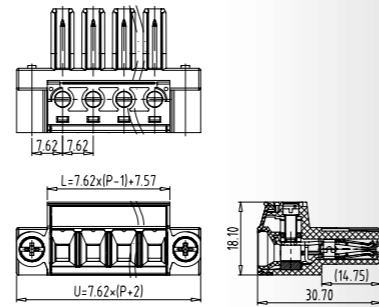
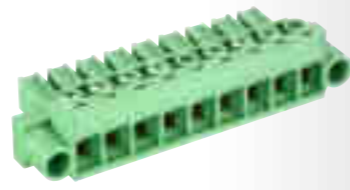

技术数据 Technical data	
Pitch (间距):	7.62mm
Approval (认证):	UL VDE
Rated voltage (电压):	300V 1000V
Rated current (电流):	30A 32A
Wire range (线径):	30-10AWG 0.2-4mm ²
Screw (螺丝):	M3
料号 Part Number	
极数 (Poles)	型号 (Model)
02	TLPSW-516V-02P
:	:
16	TLPSW-516V-16P

TLPSW-900V

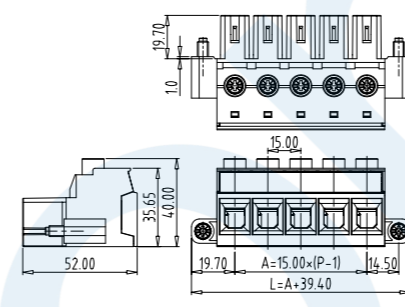

技术数据 Technical data	
Pitch (间距):	15.00mm
Approval (认证):	UL VDE
Rated voltage (电压):	600V 1000V
Rated current (电流):	115A 125A
Wire range (线径):	20-2AWG 0.5-35mm ²
Screw (螺丝):	M5
料号 Part Number	
极数 (Poles)	型号 (Model)
02	TLPSW-900V-02P
:	:
08	TLPSW-900V-08P

TLPS-800V

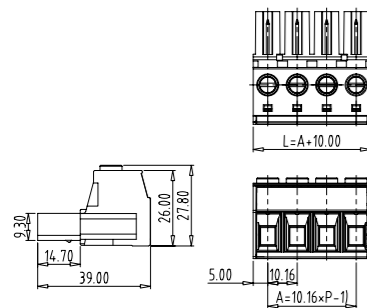

技术数据 Technical data	
Pitch (间距):	10.16mm
Approval (认证):	UL VDE
Rated voltage (电压):	600V 1000V
Rated current (电流):	55A 76A
Wire range (线径):	20-6AWG 0.5-16mm ²
Screw (螺丝):	M4
料号 Part Number	
极数 (Poles)	型号 (Model)
02	TLPS-800V-02P
:	:
12	TLPS-800V-12P

TLPSW-800V

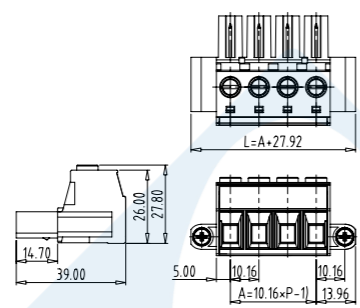

技术数据 Technical data	
Pitch (间距):	10.16mm
Approval (认证):	UL VDE
Rated voltage (电压):	600V 1000V
Rated current (电流):	55A 76A
Wire range (线径):	20-6AWG 0.5-16mm ²
Screw (螺丝):	M4
料号 Part Number	
极数 (Poles)	型号 (Model)
02	TLPSW-800V-02P
:	:
12	TLPSW-800V-12P

TLPS-900V

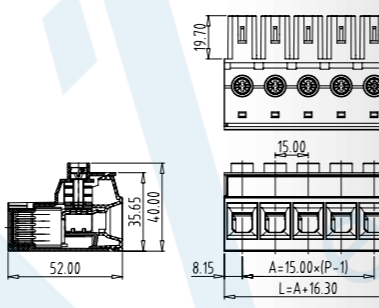
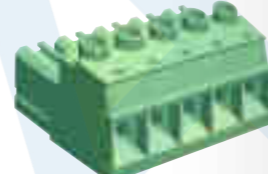

技术数据 Technical data	
Pitch (间距):	15.00mm
Approval (认证):	UL VDE(Applying)
Rated voltage (电压):	600V 1000V
Rated current (电流):	115A 125A
Wire range (线径):	20-2AWG 0.5-35mm ²
Screw (螺丝):	M5
料号 Part Number	
极数 (Poles)	型号 (Model)
02	TLPS-900V-02P
:	:
08	TLPS-900V-08P

TLPH SERIES – Header(Male) for Pluggable Terminal Block

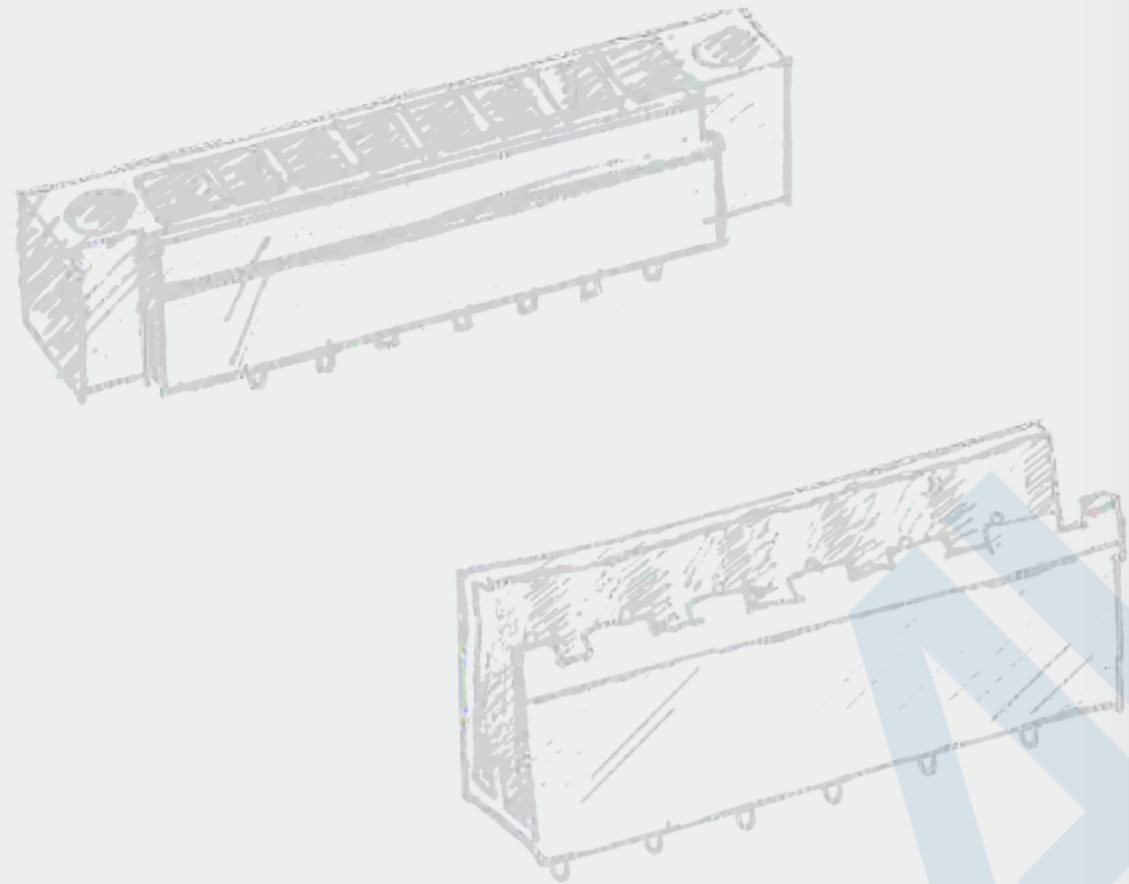

TLPHC-006V

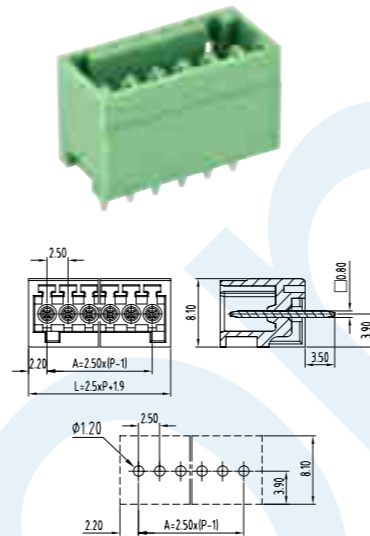

技术数据 Technical data	
Pitch (间距):	2.50mm
Approval (认证):	UL
Rated voltage (电压):	150V
Rated current (电流):	5A
PCB hole Dia(PCB直径):	Φ 1.3mm
料号 Part Number	
极数 (Poles)	型号 (Model)
02	TLPHC-006V-02P
:	:
24	TLPHC-006V-24P

TLPHC-006R

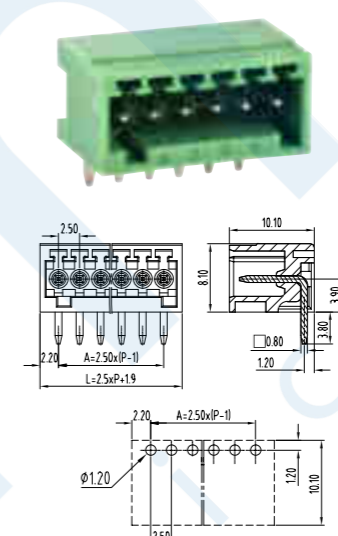

技术数据 Technical data	
Pitch (间距):	2.50mm
Approval (认证):	UL
Rated voltage (电压):	150V
Rated current (电流):	5A
PCB hole Dia(PCB直径):	Φ 1.3mm
料号 Part Number	
极数 (Poles)	型号 (Model)
02	TLPHC-006R-02P
:	:
24	TLPHC-006R-24P

TLPHC-001V(TLPHC-100V)

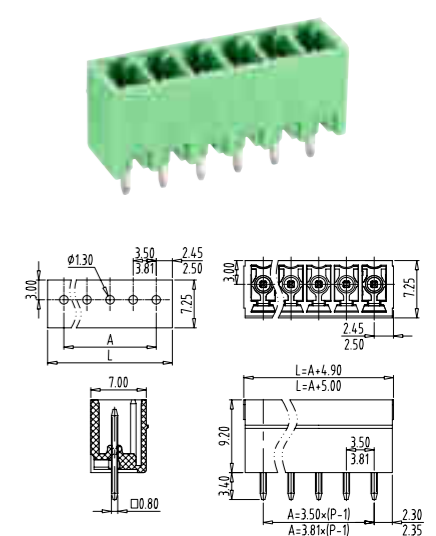

技术数据 Technical data	
Pitch (间距):	3.50mm(3.81mm)
Approval (认证):	UL
Rated voltage (电压):	300V 150V
Rated current (电流):	13A 10A
PCB hole Dia(PCB直径):	Φ 1.3mm
料号 Part Number	
极数 (Poles)	型号 (Model)
02	TLPHC-001V-02P(TLPHC-100V-02P)
:	:
24	TLPHC-001V-24P(TLPHC-100V-24P)

TLPHW-001V(TLPHW-100V)

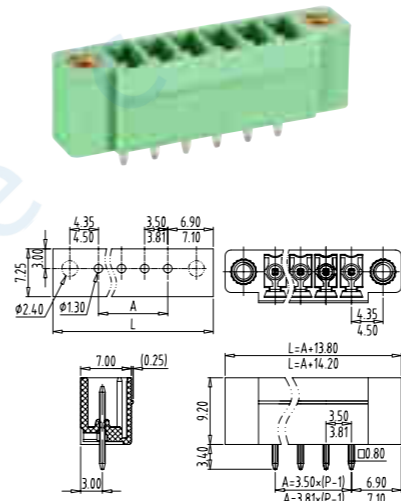

技术数据 Technical data	
Pitch (间距):	3.50mm(3.81mm)
Approval (认证):	UL
Rated voltage (电压):	300V 150V
Rated current (电流):	13A 10A
PCB hole Dia(PCB直径):	Φ 1.3mm
料号 Part Number	
极数 (Poles)	型号 (Model)
02	TLPHW-001V-02P(TLPHW-100V-02P)
:	:
24	TLPHW-001V-24P(TLPHW-100V-24P)

TLPHC-001R(TLPHC-100R)

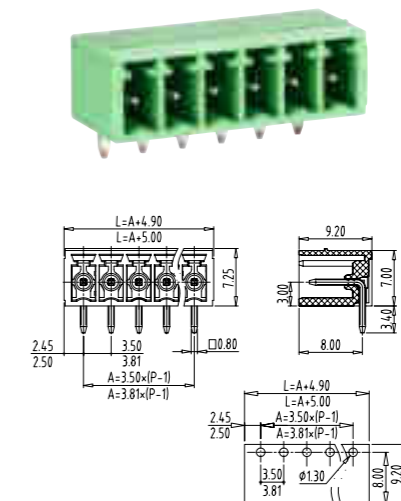

技术数据 Technical data	
Pitch (间距):	3.50mm(3.81mm)
Approval (认证):	UL
Rated voltage (电压):	300V 150V
Rated current (电流):	13A 10A
PCB hole Dia(PCB直径):	Φ 1.3mm
料号 Part Number	
极数 (Poles)	型号 (Model)
02	TLPHC-001R-02P(TLPHC-100R-02P)
:	:
24	TLPHC-001R-24P(TLPHC-100R-24P)

TLPHW-001R(TLPHW-100R)

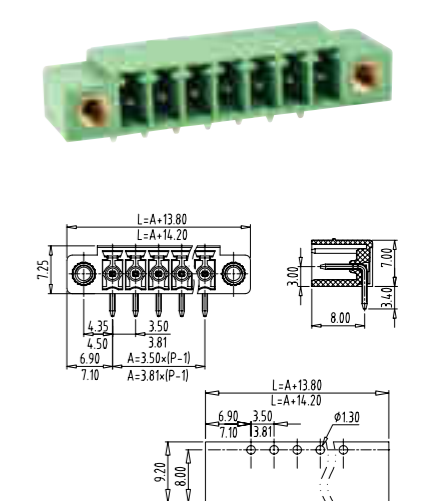

技术数据 Technical data	
Pitch (间距):	3.50mm(3.81mm)
Approval (认证):	UL
Rated voltage (电压):	300V 150V
Rated current (电流):	13A 10A
PCB hole Dia(PCB直径):	Φ 1.3mm
料号 Part Number	
极数 (Poles)	型号 (Model)
02	TLPHW-001R-02P(TLPHW-100R-02P)
:	:
24	TLPHW-001R-24P(TLPHW-100R-24P)

How to order

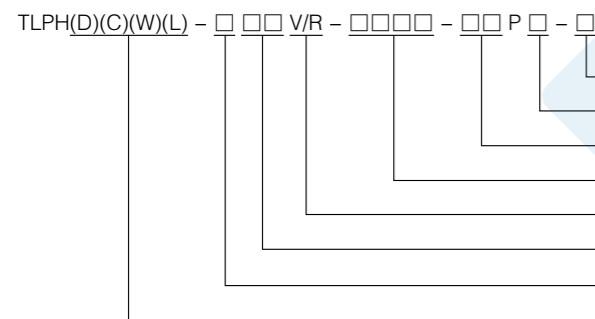

- Color: K=Black, G(G12)=Green
- 5=Double pitch, None=Standard pitch
- Poles
- Special code
- V=180°, R=90°
- Series number
- Pitch: 0=3.50, 1=3.81, 2=5.00, 3=5.08, 4=7.50, 5=7.62, 8=10.16, 9=15.00
- D=Double row, C=With side panels, L=With engagement noses

TLPH-200R(TLPH-300R)

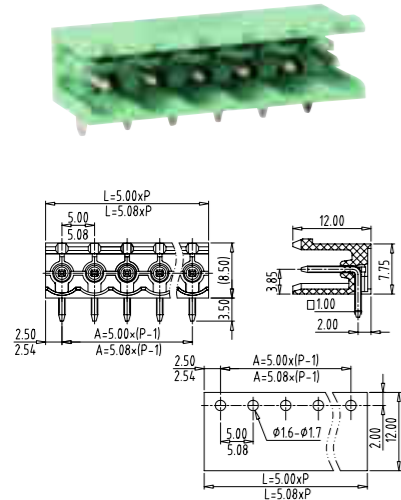

技术数据 Technical data	
Pitch (间距):	5.00mm(5.08mm)
Approval (认证):	
Rated voltage (电压):	300V 320V
Rated current (电流):	16A 20A
PCB hole Dia(PCB 直径):	Φ 1.6–1.7mm
料号 Part Number	
极数 (Poles)	型号 (Model)
02	TLPH-200R-02P(TLPH-300R-02P)
:	:
24	TLPH-200R-24P(TLPH-300R-24P)

TLPHC-200R(TLPHC-300R)

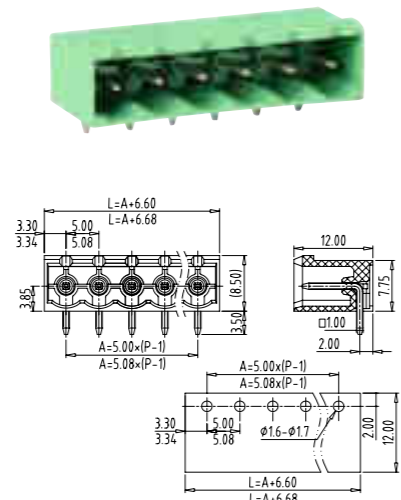

技术数据 Technical data	
Pitch (间距):	5.00mm(5.08mm)
Approval (认证):	
Rated voltage (电压):	300V 320V
Rated current (电流):	16A 20A
PCB hole Dia(PCB 直径):	Φ 1.6–1.7mm
料号 Part Number	
极数 (Poles)	型号 (Model)
02	TLPHC-200R-02P(TLPHC-300R-02P)
:	:
24	TLPHC-200R-24P(TLPHC-300R-24P)

TLPHW-200R(TLPHW-300R)

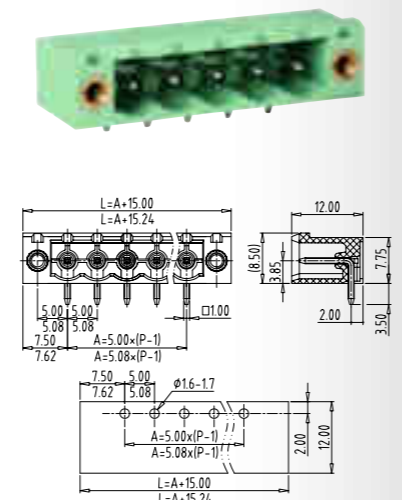

技术数据 Technical data	
Pitch (间距):	5.00mm(5.08mm)
Approval (认证):	
Rated voltage (电压):	300V 320V
Rated current (电流):	16A 20A
PCB hole Dia(PCB 直径):	Φ 1.6–1.7mm
料号 Part Number	
极数 (Poles)	型号 (Model)
02	TLPHW-200R-02P(TLPHW-300R-02P)
:	:
24	TLPHW-200R-24P(TLPHW-300R-24P)

TLPHW-300R-0544

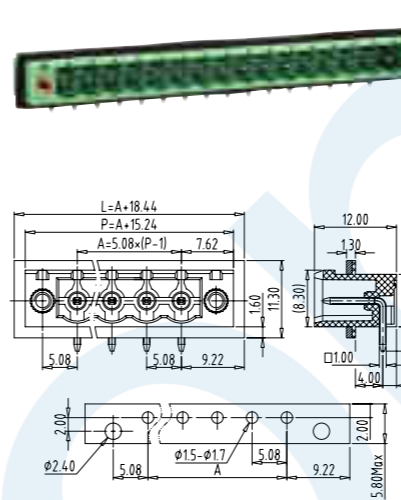

技术数据 Technical data	
Pitch (间距):	5.08mm
Approval (认证):	
Rated voltage (电压):	300V
Rated current (电流):	16A
PCB hole Dia(PCB 直径):	Φ 1.5–1.7mm
料号 Part Number	
极数 (Poles)	型号 (Model)
02	TLPHW-300R-0544-02P
:	:
24	TLPHW-300R-0544-24P

TLPH-225

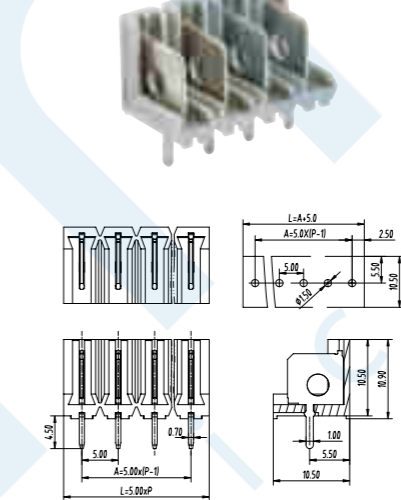

技术数据 Technical data	
Pitch (间距):	5.00mm
Approval (认证):	
Rated voltage (电压):	300V 630V
Rated current (电流):	15A 20A
PCB hole Dia(PCB 直径):	Φ 1.3–1.5mm
料号 Part Number	
极数 (Poles)	型号 (Model)
02	TLPH-225-02P
:	:
36	TLPH-225-36P

TLPH-201R

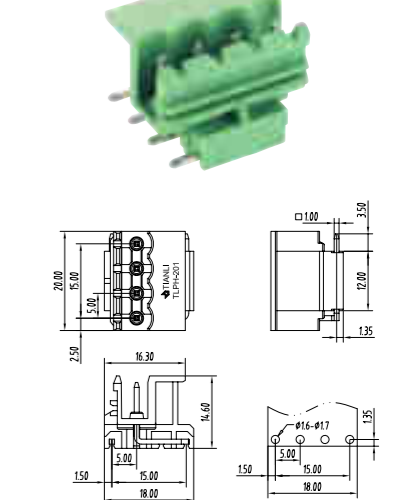

技术数据 Technical data	
Pitch (间距):	5.00mm
Approval (认证):	
Rated voltage (电压):	300V 630V
Rated current (电流):	16A 20A
PCB hole Dia(PCB 直径):	Φ 1.6–1.7mm
料号 Part Number	
极数 (Poles)	型号 (Model)
02	TLPH-201R-02P
:	:
04	TLPH-201R-04P

TLPH-200R-1603(TLPH-300R-1603)

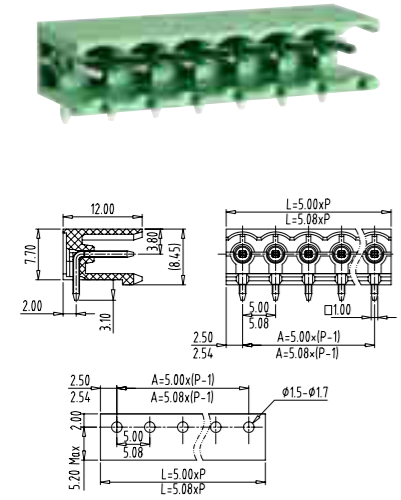

技术数据 Technical data	
Pitch (间距):	5.00mm(5.08mm)
Approval (认证):	
Rated voltage (电压):	300V 320V
Rated current (电流):	16A 20A
PCB hole Dia(PCB 直径):	Φ 1.5–1.7mm
料号 Part Number	
极数 (Poles)	型号 (Model)
02	TLPH-200R-1603-02P(TLPH-300R-1603-02P)
:	:
24	TLPH-200R-1603-24P(TLPH-300R-1603-24P)

TLPHC-200R-1603(TLPHC-300R-1603)

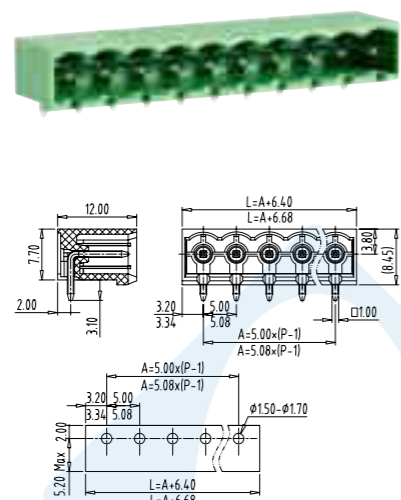

技术数据 Technical data	
Pitch (间距):	5.00mm(5.08mm)
Approval (认证):	
Rated voltage (电压):	300V 320V
Rated current (电流):	16A 20A
PCB hole Dia(PCB 直径):	Φ 1.5–1.7mm
料号 Part Number	
极数 (Poles)	型号 (Model)
02	TLPHC-200R-1603-02P(TLPHC-300R-1603-02P)
:	:
24	TLPHC-200R-1603-24P(TLPHC-300R-1603-24P)

TLPHW-200R-1603(TLPHW-300R-1603)

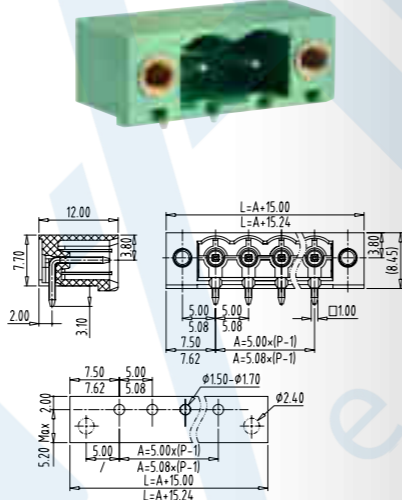

技术数据 Technical data	
Pitch (间距):	5.00mm(5.08mm)
Approval (认证):	
Rated voltage (电压):	300V 320V
Rated current (电流):	16A 20A
PCB hole Dia(PCB 直径):	Φ 1.5–1.7mm
料号 Part Number	
极数 (Poles)	型号 (Model)
02	TLPHW-200R-1603-02P(TLPHW-300R-1603-02P)
:	:
24	TLPHW-200R-1603-24P(TLPHW-300R-1603-24P)

TLPH-201RL

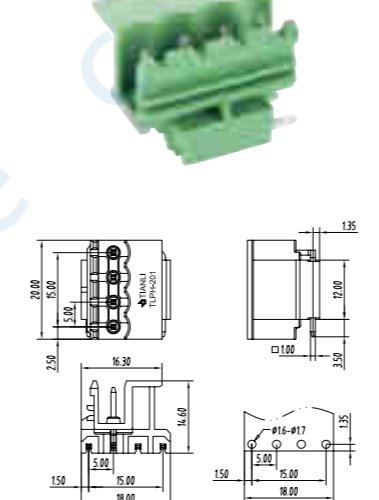

技术数据 Technical data	
Pitch (间距):	5.00mm
Approval (认证):	
Rated voltage (电压):	300V 630V
Rated current (电流):	16A 20A
PCB hole Dia(PCB 直径):	Φ 1.6–1.7mm
料号 Part Number	
极数 (Poles)	型号 (Model)
02	TLPH-201RL-02P
:	:
04	TLPH-201RL-04P

TLPHW-306

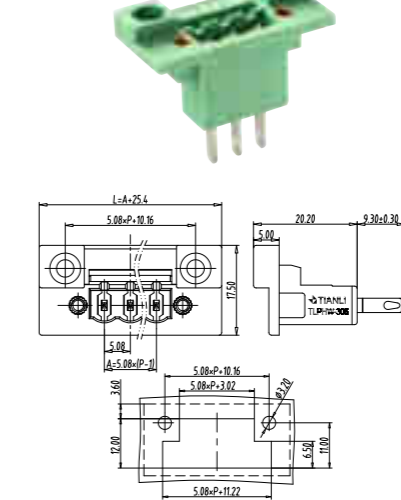

技术数据 Technical data	
Pitch (间距):	5.08mm
Approval (认证):	
Rated voltage (电压):	300V 630V
Rated current (电流):	16A 18A
PCB hole Dia(PCB 直径):	Φ 1.6–1.7mm
料号 Part Number	
极数 (Poles)	型号 (Model)
02	TLPHW-306-02P
:	:
24	TLPHW-306-24P

TLPH-300A

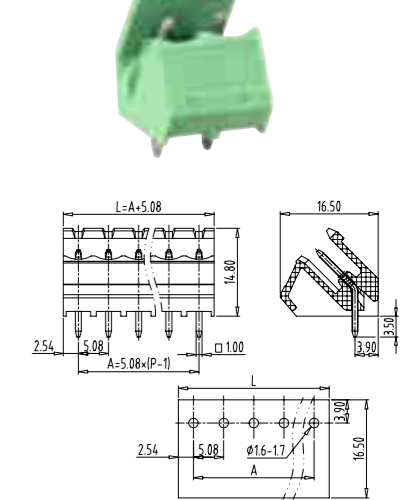

技术数据 Technical data	
Pitch (间距):	5.08mm
Approval (认证):	
Rated voltage (电压):	300V 630V
Rated current (电流):	16A 20A
PCB hole Dia(PCB 直径):	Φ 1.6–1.7mm
料号 Part Number	
极数 (Poles)	型号 (Model)
02	TLPH-300A-02P
:	:
24	TLPH-300A-24P

TLPH-500RL

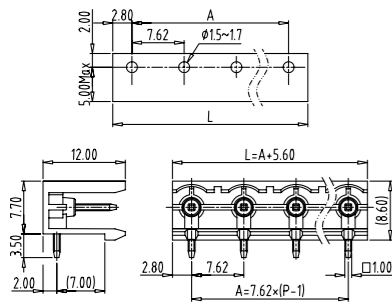

技术数据 Technical data	
Pitch (间距):	7.62mm
Approval (认证):	CUL(Applying) VDE(Applying)
Rated voltage (电压):	300V 630V
Rated current (电流):	16A 20A
PCB hole Dia(PCB直径):	Φ1.5-1.7mm
料号 Part Number	
极数 (Poles)	型号 (Model)
02	TLPH-500RL-02P
:	:
12	TLPH-500RL-12P

TLPHC-500RL

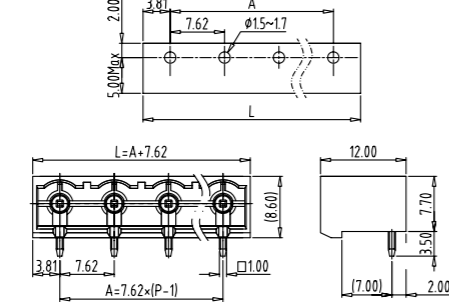

技术数据 Technical data	
Pitch (间距):	7.62mm
Approval (认证):	CUL(Applying) VDE(Applying)
Rated voltage (电压):	300V 630V
Rated current (电流):	16A 20A
PCB hole Dia(PCB直径):	Φ1.5-1.7mm
料号 Part Number	
极数 (Poles)	型号 (Model)
02	TLPHC-500RL-02P
:	:
12	TLPHC-500RL-12P

TLPHW-500RL

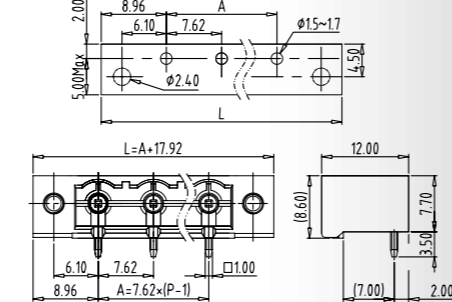

技术数据 Technical data	
Pitch (间距):	7.62mm
Approval (认证):	CUL(Applying) VDE(Applying)
Rated voltage (电压):	300V 630V
Rated current (电流):	16A 20A
PCB hole Dia(PCB直径):	Φ1.5-1.7mm
料号 Part Number	
极数 (Poles)	型号 (Model)
02	TLPHW-500RL-02P
:	:
12	TLPHW-500RL-12P

TLPHW-501R

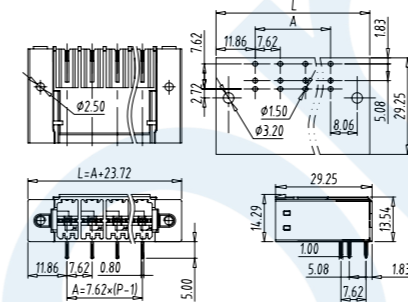

技术数据 Technical data	
Pitch (间距):	7.62mm
Approval (认证):	UL
Rated voltage (电压):	300V 630V
Rated current (电流):	41A 41A
PCB hole Dia(PCB直径):	Φ1.5mm
料号 Part Number	
极数 (Poles)	型号 (Model)
02	TLPHW-501R-02P
:	:
16	TLPHW-501R-16P

TLPHC-501RL

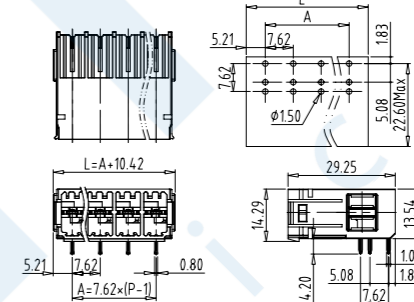

技术数据 Technical data	
Pitch (间距):	7.62mm
Approval (认证):	UL
Rated voltage (电压):	300V 630V
Rated current (电流):	41A 41A
PCB hole Dia(PCB直径):	Φ1.5mm
料号 Part Number	
极数 (Poles)	型号 (Model)
02	TLPHC-501RL-02P
:	:
16	TLPHC-501RL-16P

TLPHW-501RL

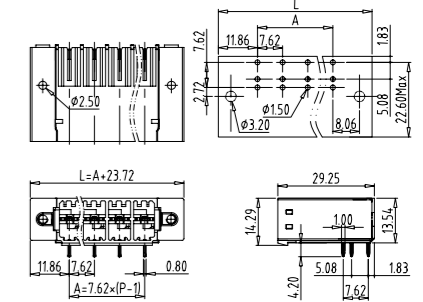

技术数据 Technical data	
Pitch (间距):	7.62mm
Approval (认证):	UL
Rated voltage (电压):	300V 630V
Rated current (电流):	41A 41A
PCB hole Dia(PCB直径):	Φ1.5mm
料号 Part Number	
极数 (Poles)	型号 (Model)
02	TLPHW-501RL-02P
:	:
16	TLPHW-501RL-16P

TLPHC-501V

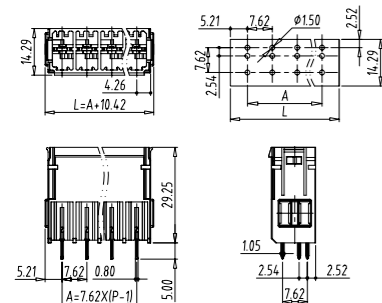

技术数据 Technical data	
Pitch (间距):	7.62mm
Approval (认证):	UL
Rated voltage (电压):	300V 630V
Rated current (电流):	41A 41A
PCB hole Dia(PCB直径):	Φ1.5mm
料号 Part Number	
极数 (Poles)	型号 (Model)
02	TLPHC-501V-02P
:	:
16	TLPHC-501V-16P

TLPHW-501V

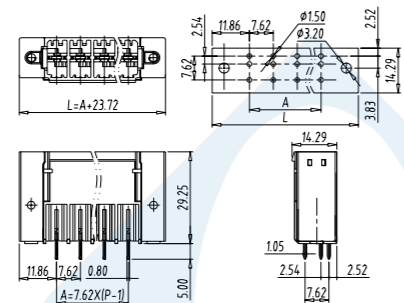
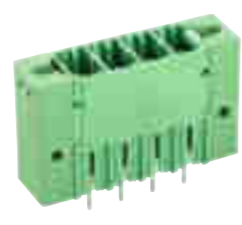

技术数据 Technical data	
Pitch (间距):	7.62mm
Approval (认证):	UL
Rated voltage (电压):	300V 630V
Rated current (电流):	41A 41A
PCB hole Dia(PCB直径):	Φ1.5mm
料号 Part Number	
极数 (Poles)	型号 (Model)
02	TLPHW-501V-02P
:	:
16	TLPHW-501V-16P

TLPHC-501R

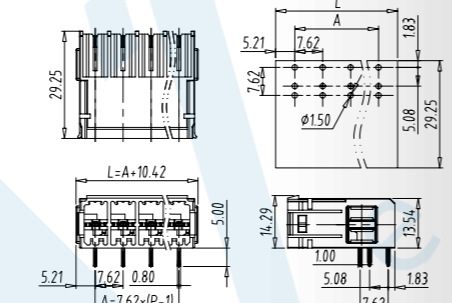

技术数据 Technical data	
Pitch (间距):	7.62mm
Approval (认证):	UL
Rated voltage (电压):	300V 630V
Rated current (电流):	41A 41A
PCB hole Dia(PCB直径):	Φ1.5mm
料号 Part Number	
极数 (Poles)	型号 (Model)
02	TLPHC-501R-02P
:	:
16	TLPHC-501R-16P

TLPHC-516V

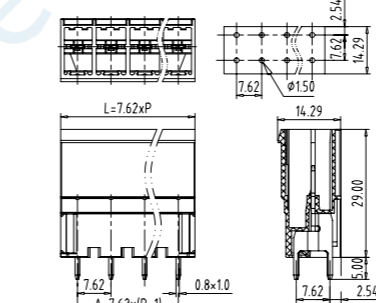
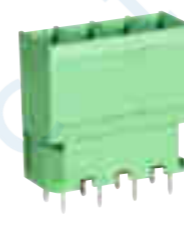

技术数据 Technical data	
Pitch (间距):	7.62mm
Approval (认证):	UL
Rated voltage (电压):	300V 1000V
Rated current (电流):	30A 32A
PCB hole Dia(PCB直径):	Φ1.5mm
料号 Part Number	
极数 (Poles)	型号 (Model)
02	TLPHC-516V-02P
:	:
16	TLPHC-516V-16P

TLPHW-516V

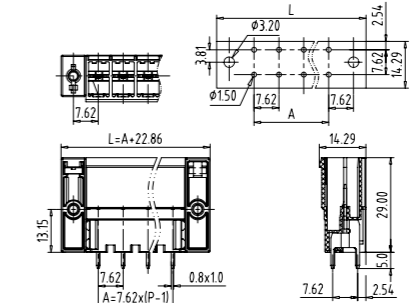
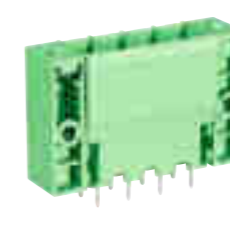

技术数据 Technical data	
Pitch (间距):	7.62mm
Approval (认证):	UL
Rated voltage (电压):	300V 1000V
Rated current (电流):	30A 32A
PCB hole Dia(PCB直径):	Φ1.5mm
料号 Part Number	
极数 (Poles)	型号 (Model)
02	TLPHW-516V-02P
:	:
16	TLPHW-516V-16P

TLPHC-516R

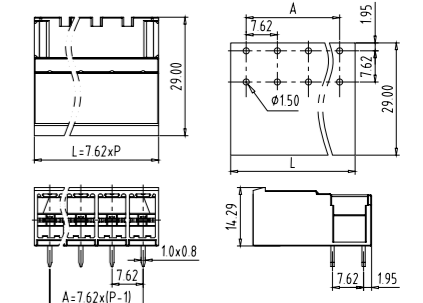

技术数据 Technical data	
Pitch (间距):	7.62mm
Approval (认证):	UL
Rated voltage (电压):	300V 1000V
Rated current (电流):	30A 32A
PCB hole Dia(PCB直径):	Φ1.5mm
料号 Part Number	
极数 (Poles)	型号 (Model)
02	TLPHC-516R-02P
:	:
16	TLPHC-516R-16P

TLPHW-516R

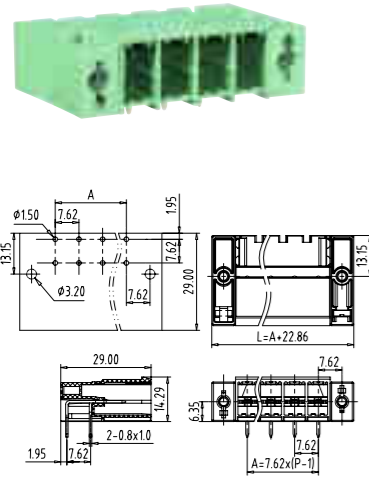

技术数据 Technical data	
Pitch (间距):	7.62mm
Approval (认证):	UL, CE, Ex
Rated voltage (电压):	300V 1000V
Rated current (电流):	30A 32A
PCB hole Dia(PCB 直径):	Φ 1.5mm

料号 Part Number	
极数 (Poles)	型号 (Model)
02	TLPHW-516R-02P
:	:
16	TLPHW-516R-16P

TLPHC-800V

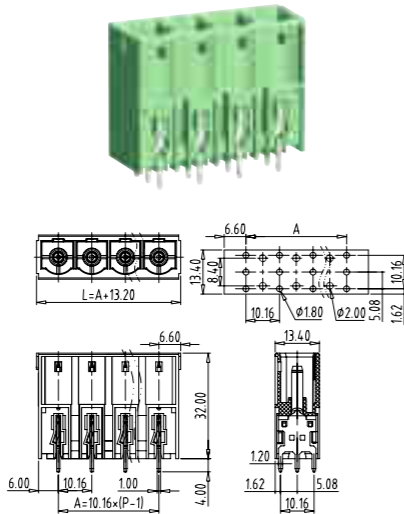

技术数据 Technical data	
Pitch (间距):	10.16mm
Approval (认证):	UL, CE, Ex
Rated voltage (电压):	300V 1000V
Rated current (电流):	55A 76A
PCB hole Dia(PCB 直径):	Φ 1.8mm

料号 Part Number	
极数 (Poles)	型号 (Model)
02	TLPHC-800V-02P
:	:
11	TLPHC-800V-11P

TLPHW-800V

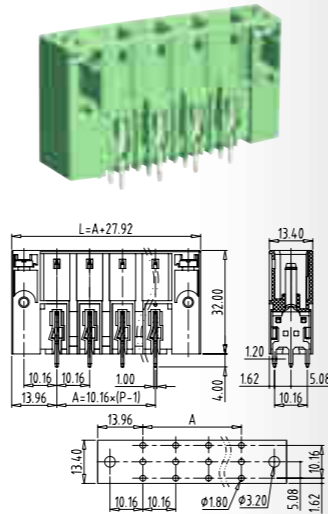

技术数据 Technical data	
Pitch (间距):	10.16mm
Approval (认证):	UL, CE, Ex
Rated voltage (电压):	300V 1000V
Rated current (电流):	55A 76A
PCB hole Dia(PCB 直径):	Φ 1.8mm

料号 Part Number	
极数 (Poles)	型号 (Model)
02	TLPHW-800V-02P
:	:
10	TLPHW-800V-10P

TLPHW-800RL

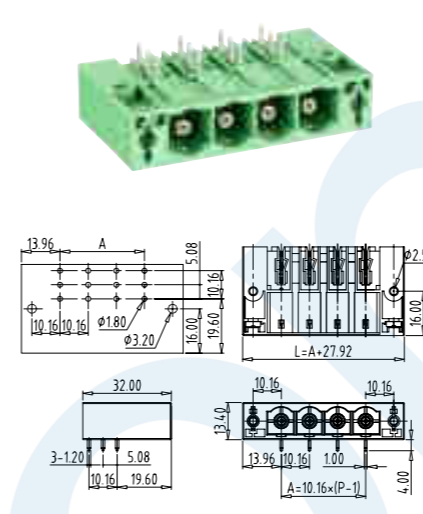

技术数据 Technical data	
Pitch (间距):	10.16mm
Approval (认证):	UL, CE, Ex
Rated voltage (电压):	600V 1000V
Rated current (电流):	55A 76A
PCB hole Dia(PCB 直径):	Φ 1.8mm

料号 Part Number	
极数 (Poles)	型号 (Model)
02	TLPHW-800RL-02P
:	:
10	TLPHW-800RL-10P

TLPHC-900V

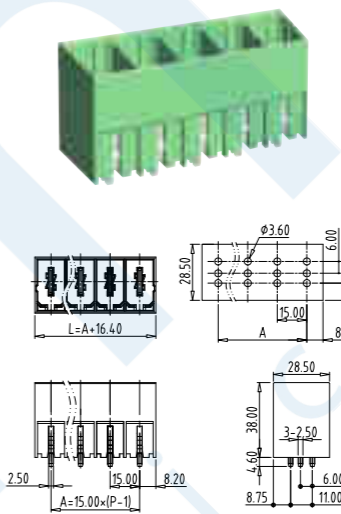

技术数据 Technical data	
Pitch (间距):	15.00mm
Approval (认证):	UL, CE, Ex, VDE(Applying)
Rated voltage (电压):	600V 1000V
Rated current (电流):	115A 125A
PCB hole Dia(PCB 直径):	Φ 3.6mm

料号 Part Number	
极数 (Poles)	型号 (Model)
02	TLPHC-900V-02P
:	:
08	TLPHC-900V-08P

TLPHW-900V

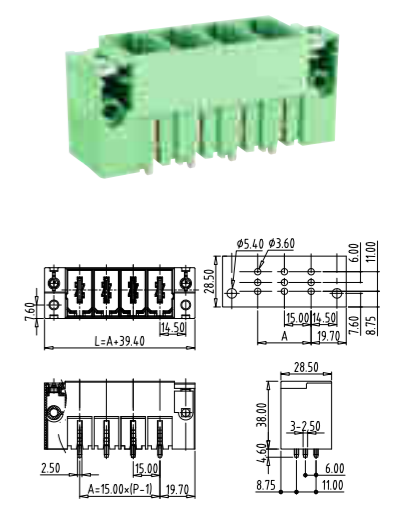

技术数据 Technical data	
Pitch (间距):	15.00mm
Approval (认证):	UL, CE, Ex
Rated voltage (电压):	600V 1000V
Rated current (电流):	115A 125A
PCB hole Dia(PCB 直径):	Φ 3.6mm

料号 Part Number	
极数 (Poles)	型号 (Model)
02	TLPHW-900V-02P
:	:
08	TLPHW-900V-08P

TLPHC-800R

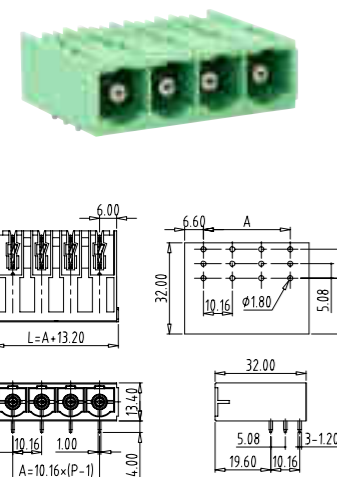

技术数据 Technical data	
Pitch (间距):	10.16mm
Approval (认证):	UL, CE, Ex
Rated voltage (电压):	300V 1000V
Rated current (电流):	55A 76A
PCB hole Dia(PCB 直径):	Φ 1.8mm

料号 Part Number	
极数 (Poles)	型号 (Model)
02	TLPHC-800R-02P
:	:
11	TLPHC-800R-11P

TLPHW-800R

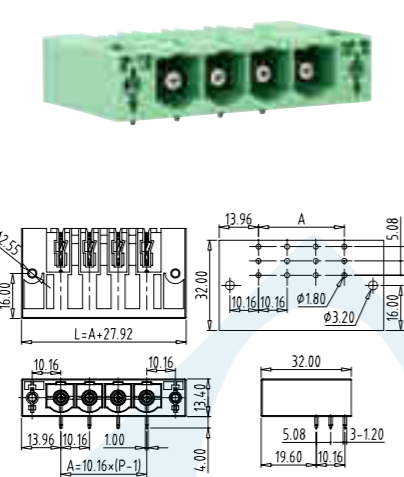

技术数据 Technical data	
Pitch (间距):	10.16mm
Approval (认证):	UL, CE, Ex
Rated voltage (电压):	300V 1000V
Rated current (电流):	55A 76A
PCB hole Dia(PCB 直径):	Φ 1.8mm

料号 Part Number	
极数 (Poles)	型号 (Model)
02	TLPHW-800R-02P
:	:
10	TLPHW-800R-10P

TLPHC-800RL

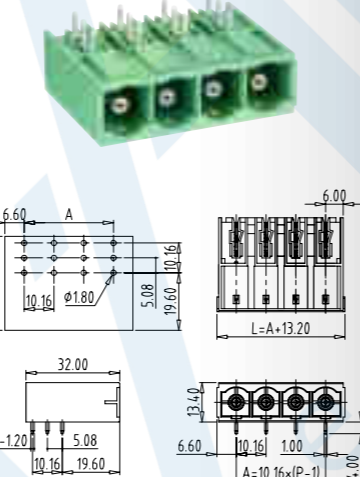

技术数据 Technical data	
Pitch (间距):	10.16mm
Approval (认证):	UL, CE, Ex
Rated voltage (电压):	300V 1000V
Rated current (电流):	55A 76A
PCB hole Dia(PCB 直径):	Φ 1.8mm

料号 Part Number	
极数 (Poles)	型号 (Model)
02	TLPHC-800RL-02P
:	:
11	TLPHC-800RL-11P

TLPHC-900R

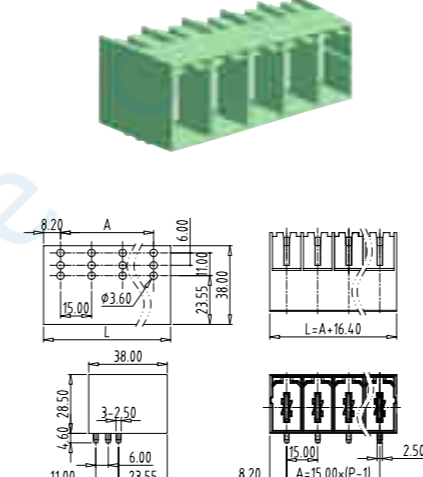

技术数据 Technical data	
Pitch (间距):	15.00mm
Approval (认证):	UL, CE, Ex, VDE(Applying)
Rated voltage (电压):	600V 1000V
Rated current (电流):	115A 125A
PCB hole Dia(PCB 直径):	Φ 3.6mm

料号 Part Number	
极数 (Poles)	型号 (Model)
02	TLPHC-900R-02P
:	:
08	TLPHC-900R-08P

TLPHW-900R

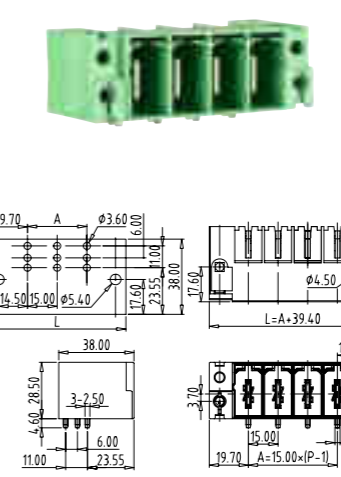

技术数据 Technical data	
Pitch (间距):	15.00mm
Approval (认证):	UL, CE, Ex, VDE(Applying)
Rated voltage (电压):	600V 1000V
Rated current (电流):	115A 125A
PCB hole Dia(PCB 直径):	Φ 3.6mm

料号 Part Number	
极数 (Poles)	型号 (Model)
02	TLPHW-900R-02P
:	:
08	TLPHW-900R-08P

TLB21-002

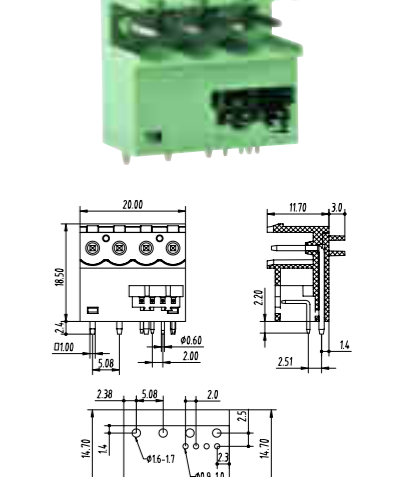

技术数据 Technical data	
Pitch (间距):	2.0mm (5.08mm)
Rated voltage (电压):	50V
Rated current (电流):	12A/3A
PCB hole Dia(PCB 直径):	Φ 1.6-1.7mm/Φ 1.0mm

料号 Part Number	
极数 (Poles)	型号 (Model)
-	TLB21-002

TLPHDL-007V

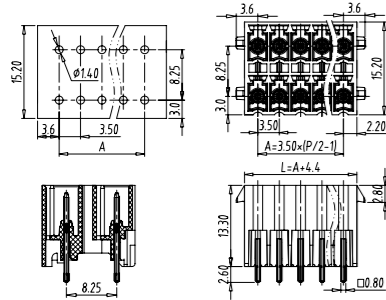
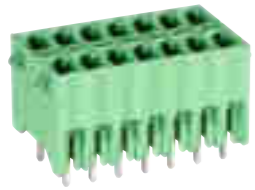

技术数据 Technical data	
Pitch (间距):	3.50mm
Approval (认证):	
Rated voltage (电压):	300V 160V
Rated current (电流):	8A 10A
PCB hole Dia(PCB直径):	Φ 1.3mm
料号 Part Number	
极数 (Poles)	型号 (Model)
04	TLPHDL-007V-04P
:	:
48	TLPHDL-007V-48P

TLPHDC-007R

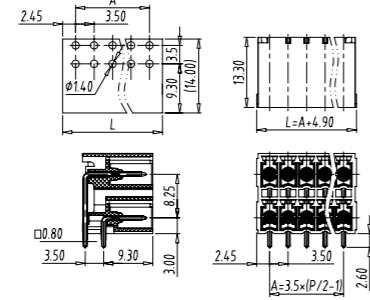

技术数据 Technical data	
Pitch (间距):	3.50mm
Approval (认证):	
Rated voltage (电压):	300V 160V
Rated current (电流):	8A 10A
PCB hole Dia(PCB直径):	Φ 1.3mm
料号 Part Number	
极数 (Poles)	型号 (Model)
04	TLPHDC-007R-04P
:	:
48	TLPHDC-007R-48P

TLPHDL-007R

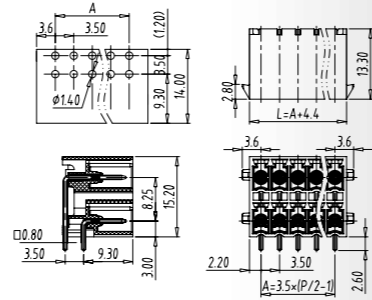
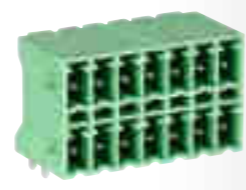

技术数据 Technical data	
Pitch (间距):	3.50mm
Approval (认证):	
Rated voltage (电压):	300V 160V
Rated current (电流):	8A 10A
PCB hole Dia(PCB直径):	Φ 1.3mm
料号 Part Number	
极数 (Poles)	型号 (Model)
04	TLPHDL-007R-04P
:	:
48	TLPHDL-007R-48P

TLPHDC-008R(TLPHDC-108R)

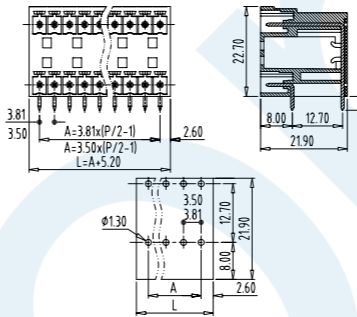
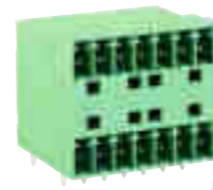

技术数据 Technical data	
Pitch (间距):	3.50mm (3.81mm)
Approval (认证):	
Rated voltage (电压):	300V 160V(3.5) 320V(3.81)
Rated current (电流):	8A 10A
PCB hole Dia(PCB直径):	Φ 1.3mm
料号 Part Number	
极数 (Poles)	型号 (Model)
04	TLPHDC-008R-04P(TLPHDC-108R-04P)
:	:
48	TLPHDC-008R-48P(TLPHDC-108R-48P)

TLPHDW-008R(TLPHDW-108R)

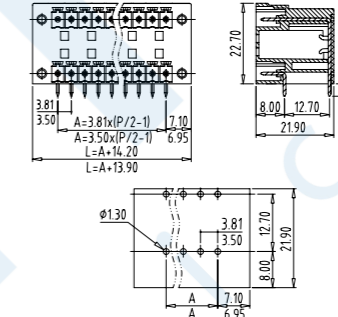
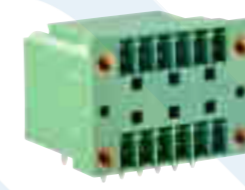

技术数据 Technical data	
Pitch (间距):	3.50mm (3.81mm)
Approval (认证):	
Rated voltage (电压):	300V 160V(3.5) 320V(3.81)
Rated current (电流):	8A 10A
PCB hole Dia(PCB直径):	Φ 1.3mm
料号 Part Number	
极数 (Poles)	型号 (Model)
04	TLPHDW-008R-04P(TLPHDW-108R-04P)
:	:
48	TLPHDW-008R-48P(TLPHDW-108R-48P)

TLPHDC-010V

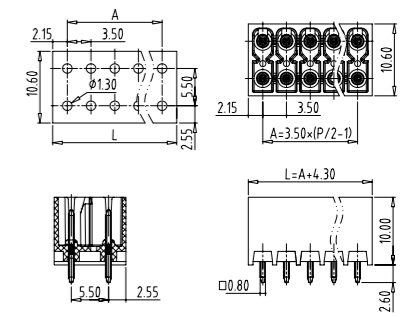
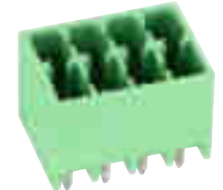

技术数据 Technical data	
Pitch (间距):	3.50mm
Approval (认证):	
Rated voltage (电压):	300V 160V
Rated current (电流):	8A 10A
PCB hole Dia(PCB直径):	Φ 1.3mm
料号 Part Number	
极数 (Poles)	型号 (Model)
04	TLPHDC-010V-04P
:	:
48	TLPHDC-010V-48P

TLPHDC-008V(TLPHDC-108V)

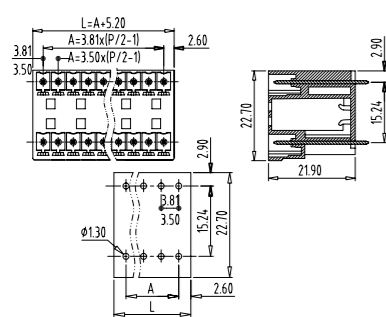
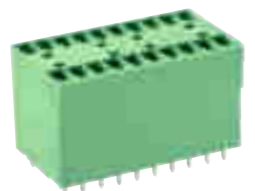

技术数据 Technical data	
Pitch (间距):	3.50mm (3.81mm)
Approval (认证):	
Rated voltage (电压):	300V 160V(3.5) 320V(3.81)
Rated current (电流):	8A 10A
PCB hole Dia(PCB直径):	Φ 1.3mm
料号 Part Number	
极数 (Poles)	型号 (Model)
04	TLPHDC-008V-04P(TLPHDC-108V-04P)
:	:
48	TLPHDC-008V-48P(TLPHDC-108V-48P)

TLPHDW-010V

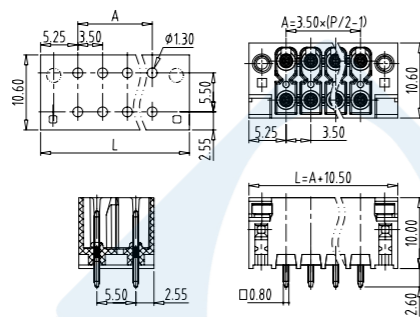

技术数据 Technical data	
Pitch (间距):	3.50mm
Approval (认证):	
Rated voltage (电压):	300V 160V
Rated current (电流):	8A 10A
PCB hole Dia(PCB直径):	Φ 1.3mm
料号 Part Number	
极数 (Poles)	型号 (Model)
04	TLPHDW-010V-04P
:	:
48	TLPHDW-010V-48P

TLPHDW-008V(TLPHDW-108V)

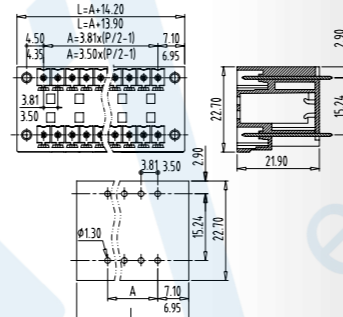
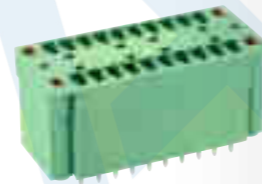

技术数据 Technical data	
Pitch (间距):	3.50mm (3.81mm)
Approval (认证):	
Rated voltage (电压):	300V 160V(3.5) 320V(3.81)
Rated current (电流):	8A 10A
PCB hole Dia(PCB直径):	Φ 1.3mm
料号 Part Number	
极数 (Poles)	型号 (Model)
04	TLPHDW-008V-04P(TLPHDW-108V-04P)
:	:
48	TLPHDW-008V-48P(TLPHDW-108V-48P)

TLPHDC-010R

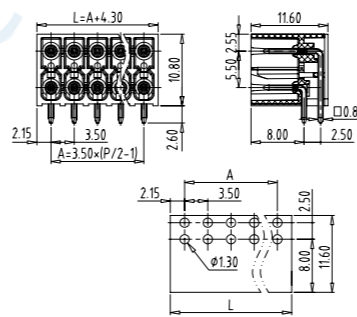

技术数据 Technical data	
Pitch (间距):	3.50mm
Approval (认证):	
Rated voltage (电压):	300V 160V
Rated current (电流):	8A 10A
PCB hole Dia(PCB直径):	Φ 1.3mm
料号 Part Number	
极数 (Poles)	型号 (Model)
04	TLPHDC-010R-04P
:	:
48	TLPHDC-010R-48P

TLPHDW-010R

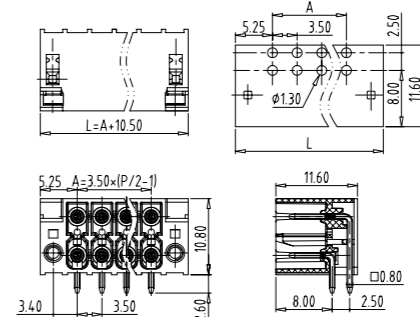

技术数据 Technical data	
Pitch (间距):	3.50mm
Approval (认证):	
Rated voltage (电压):	300V 160V
Rated current (电流):	8A 10A
PCB hole Dia(PCB直径):	Φ 1.3mm
料号 Part Number	
极数 (Poles)	型号 (Model)
04	TLPHDW-010R-04P
:	:
48	TLPHDW-010R-48P

TLPHDC-200V(TLPHDC-300V)

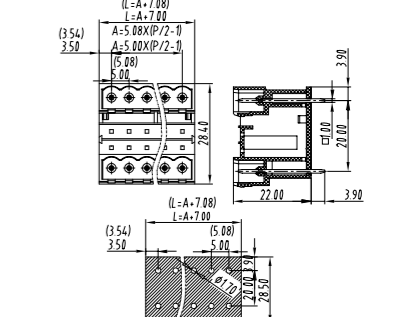
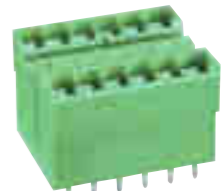

技术数据 Technical data	
Pitch (间距):	5.00mm (5.08mm)
Approval (认证):	
Rated voltage (电压):	300V 320V
Rated current (电流):	16A 20A
PCB hole Dia(PCB直径):	Φ 1.6-1.7mm
料号 Part Number	
极数 (Poles)	型号 (Model)
04	TLPHDC-200V-04P(TLPHDC-300V-04P)
:	:
48	TLPHDC-200V-48P(TLPHDC-300V-48P)

TLPHDW-200V(TLPHDW-300V)

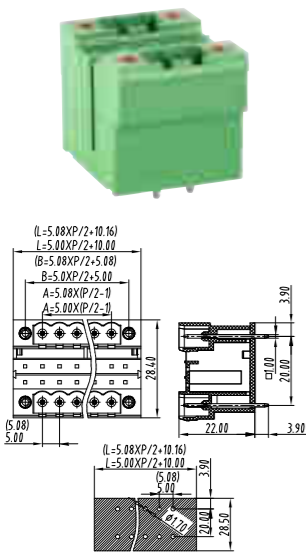

技术数据 Technical data	
Pitch (间距):	5.00mm(5.08mm)
Approval (认证):	UL, CE
Rated voltage (电压):	300V 320V
Rated current (电流):	16A 20A
PCB hole Dia(PCB直径):	Φ 1.6-1.7mm
料号 Part Number	
极数 (Poles)	型号 (Model)
04	TLPHDW-200V-04P(TLPHDW-300V-04P)
:	:
48	TLPHDW-200V-48P(TLPHDW-300V-48P)

TLPHDC-200R(TLPHDC-300R)

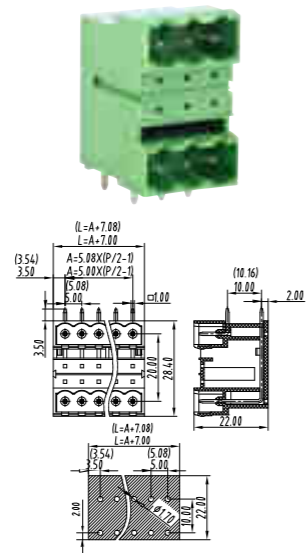

技术数据 Technical data	
Pitch (间距):	5.00mm(5.08mm)
Approval (认证):	UL, CE
Rated voltage (电压):	300V 320V
Rated current (电流):	16A 20A
PCB hole Dia(PCB直径):	Φ 1.6-1.7mm
料号 Part Number	
极数 (Poles)	型号 (Model)
04	TLPHDC-200R-04P(TLPHDC-300R-04P)
:	:
48	TLPHDC-200R-48P(TLPHDC-300R-48P)

TLPHDW-200R(TLPHDW-300R)

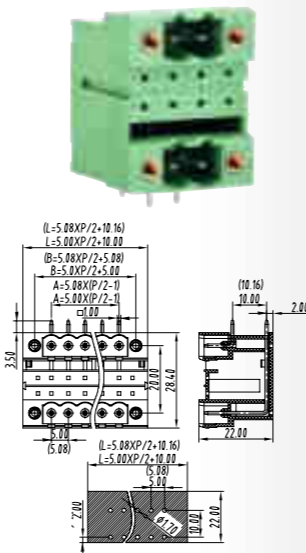

技术数据 Technical data	
Pitch (间距):	5.00mm(5.08mm)
Approval (认证):	UL, CE
Rated voltage (电压):	300V 320V
Rated current (电流):	16A 20A
PCB hole Dia(PCB直径):	Φ 1.6-1.7mm
料号 Part Number	
极数 (Poles)	型号 (Model)
04	TLPHDW-200R-04P(TLPHDW-300R-04P)
:	:
48	TLPHDW-200R-48P(TLPHDW-300R-48P)

TLPHD-203R(TLPHD-303R)

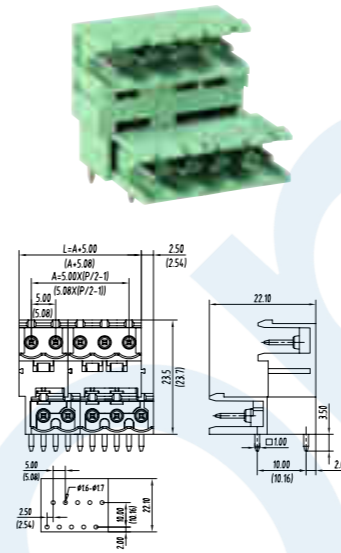

技术数据 Technical data	
Pitch (间距):	5.00mm(5.08mm)
Approval (认证):	UL, CE
Rated voltage (电压):	300V 320V
Rated current (电流):	16A 20A
PCB hole Dia(PCB直径):	Φ 1.6-1.7mm
料号 Part Number	
极数 (Poles)	型号 (Model)
04	TLPHD-203R-04P(TLPHD-303R-04P)
:	:
48	TLPHD-203R-48P(TLPHD-303R-48P)

TLPHDC-203R(TLPHDC-303R)

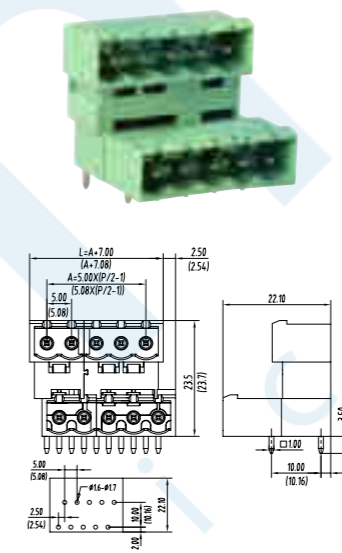

技术数据 Technical data	
Pitch (间距):	5.00mm(5.08mm)
Approval (认证):	UL, CE
Rated voltage (电压):	300V 320V
Rated current (电流):	16A 20A
PCB hole Dia(PCB直径):	Φ 1.6-1.7mm
料号 Part Number	
极数 (Poles)	型号 (Model)
04	TLPHDC-203R-04P(TLPHDC-303R-04P)
:	:
48	TLPHDC-203R-48P(TLPHDC-303R-48P)

TLPHDW-203R(TLPHDW-303R)

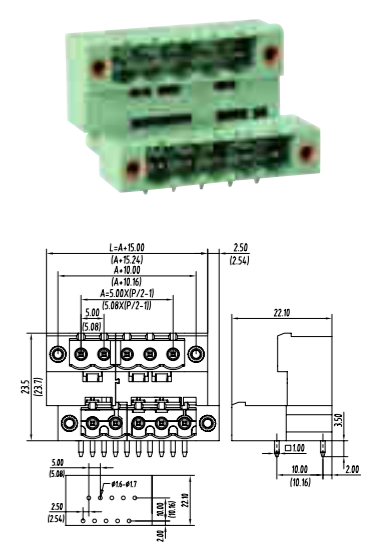

技术数据 Technical data	
Pitch (间距):	5.00mm(5.08mm)
Approval (认证):	UL, CE
Rated voltage (电压):	300V 320V
Rated current (电流):	16A 20A
PCB hole Dia(PCB直径):	Φ 1.6-1.7mm
料号 Part Number	
极数 (Poles)	型号 (Model)
04	TLPHDW-203R-04P(TLPHDW-303R-04P)
:	:
48	TLPHDW-203R-48P(TLPHDW-303R-48P)

TLPHD-203V(TLPHD-303V)

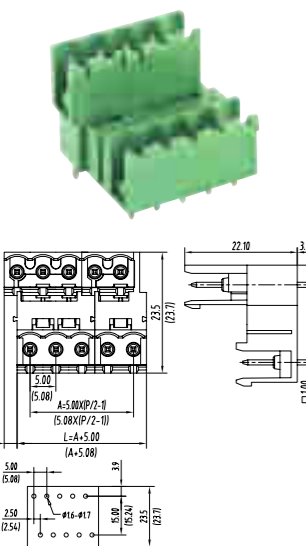

技术数据 Technical data	
Pitch (间距):	5.00mm(5.08mm)
Approval (认证):	UL, CE
Rated voltage (电压):	300V 320V
Rated current (电流):	16A 20A
PCB hole Dia(PCB直径):	Φ 1.6-1.7mm
料号 Part Number	
极数 (Poles)	型号 (Model)
04	TLPHD-203V-04P(TLPHD-303V-04P)
:	:
48	TLPHD-203V-48P(TLPHD-303V-48P)

TLPHDC-203V(TLPHDC-303V)

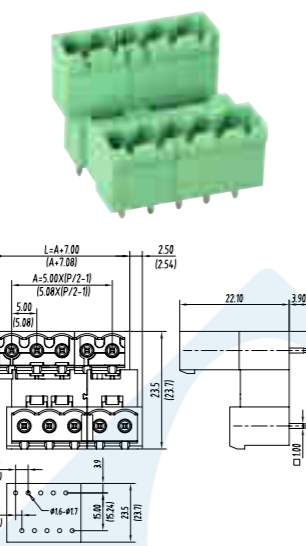

技术数据 Technical data	
Pitch (间距):	5.00mm(5.08mm)
Approval (认证):	UL, CE
Rated voltage (电压):	300V 320V
Rated current (电流):	16A 20A
PCB hole Dia(PCB直径):	Φ 1.6-1.7mm
料号 Part Number	
极数 (Poles)	型号 (Model)
04	TLPHDC-203V-04P(TLPHDC-303V-04P)
:	:
48	TLPHDC-203V-48P(TLPHDC-303V-48P)

TLPHDW-203V(TLPHDW-303V)

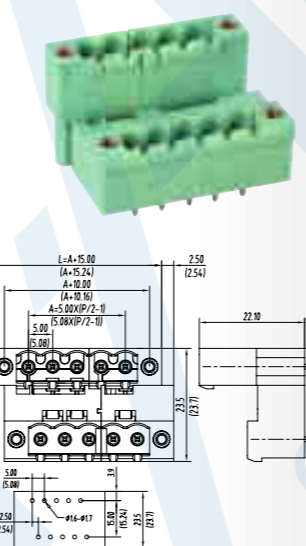

技术数据 Technical data	
Pitch (间距):	5.00mm(5.08mm)
Approval (认证):	UL, CE
Rated voltage (电压):	300V 320V
Rated current (电流):	16A 20A
PCB hole Dia(PCB直径):	Φ 1.6-1.7mm
料号 Part Number	
极数 (Poles)	型号 (Model)
04	TLPHDW-203V-04P(TLPHDW-303V-04P)
:	:
48	TLPHDW-203V-48P(TLPHDW-303V-48P)

TLPHC-001V(TLPHC-100V) HT

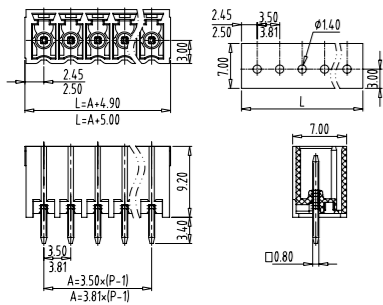
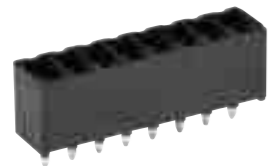

技术数据 Technical data	
Pitch (间距):	3.50mm(3.81mm)
Approval (认证):	UL, CE, RoHS
Rated voltage (电压):	300V 320V
Rated current (电流):	13A 10A
PCB hole Dia(PCB 直径):	Φ 1.4mm

料号 Part Number	
极数 (Poles)	型号 (Model)
02	TLPHC-001V(TLPHC-100V)-02P-HT
:	:
24	TLPHC-001V(TLPHC-100V)-24P-HT

TLPHL-001V(TLPHL-100V) HT

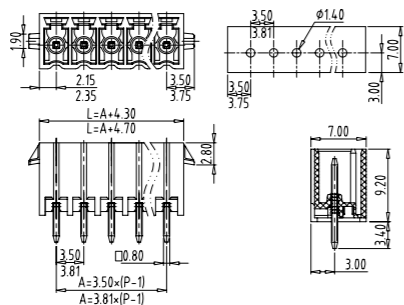

技术数据 Technical data	
Pitch (间距):	3.50mm(3.81mm)
Approval (认证):	UL, CE, RoHS, VDE(Applying)
Rated voltage (电压):	300V 320V
Rated current (电流):	13A 10A
PCB hole Dia(PCB 直径):	Φ 1.4mm

料号 Part Number	
极数 (Poles)	型号 (Model)
02	TLPHL-001V(TLPHL-100V)-02P-HT
:	:
24	TLPHL-001V(TLPHL-100V)-24P-HT

TLPHW-001V(TLPHW-100V) HT

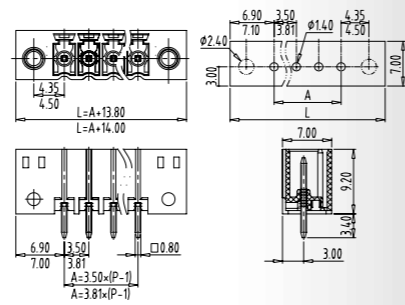

技术数据 Technical data	
Pitch (间距):	3.50mm(3.81mm)
Approval (认证):	UL, CE, RoHS, VDE(Applying)
Rated voltage (电压):	300V 320V
Rated current (电流):	13A 10A
PCB hole Dia(PCB 直径):	Φ 1.4mm

料号 Part Number	
极数 (Poles)	型号 (Model)
02	TLPHW-001V(TLPHW-100V)-02P-HT
:	:
24	TLPHW-001V(TLPHW-100V)-24P-HT

TLPH-200V(TLPH-300V) HT

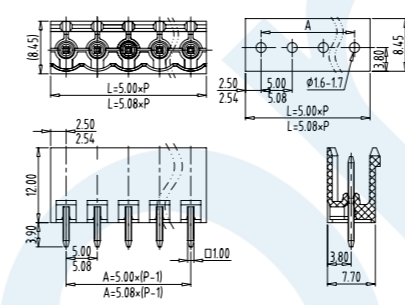

技术数据 Technical data	
Pitch (间距):	5.00mm(5.08mm)
Approval (认证):	UL, CE, RoHS, VDE(Applying)
Rated voltage (电压):	300V 630V
Rated current (电流):	16A 20A
PCB hole Dia(PCB 直径):	Φ 1.6-Φ 1.7mm

料号 Part Number	
极数 (Poles)	型号 (Model)
02	TLPH-200V(TLPH-300V)-02P-HT
:	:
24	TLPH-200V(TLPH-300V)-24P-HT

TLPHC-200V(TLPHC-300V) HT

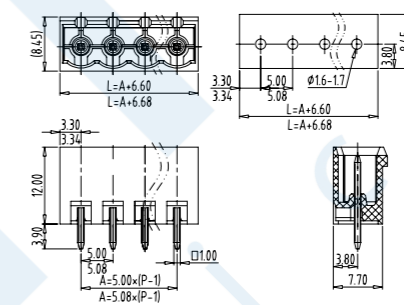

技术数据 Technical data	
Pitch (间距):	5.00mm(5.08mm)
Approval (认证):	UL, CE, RoHS, VDE(Applying)
Rated voltage (电压):	300V 630V
Rated current (电流):	16A 20A
PCB hole Dia(PCB 直径):	Φ 1.6-Φ 1.7mm

料号 Part Number	
极数 (Poles)	型号 (Model)
02	TLPHC-200V(TLPHC-300V)-02P-HT
:	:
24	TLPHC-200V(TLPHC-300V)-24P-HT

TLPHW-200V(TLPHW-300V) HT

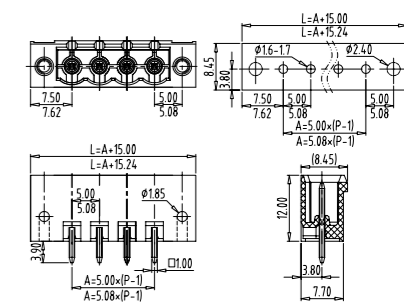

技术数据 Technical data	
Pitch (间距):	5.00mm(5.08mm)
Approval (认证):	UL, CE, RoHS, VDE(Applying)
Rated voltage (电压):	300V 630V
Rated current (电流):	16A 20A
PCB hole Dia(PCB 直径):	Φ 1.6-Φ 1.7mm

料号 Part Number	
极数 (Poles)	型号 (Model)
02	TLPHW-200V(TLPHW-300V)-02P-HT
:	:
24	TLPHW-200V(TLPHW-300V)-24P-HT

TLPHC-001R(TLPHC-100R) HT

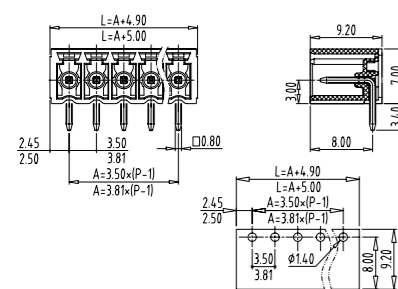
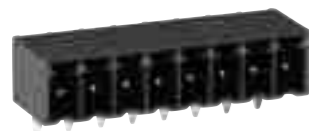

技术数据 Technical data	
Pitch (间距):	3.50mm(3.81mm)
Approval (认证):	UL, CE, RoHS
Rated voltage (电压):	300V 320V
Rated current (电流):	13A 10A
PCB hole Dia(PCB 直径):	Φ 1.4mm

料号 Part Number	
极数 (Poles)	型号 (Model)
02	TLPHC-001R(TLPHC-100R)-02P-HT
:	:
24	TLPHC-001R(TLPHC-100R)-24P-HT

TLPHL-001R(TLPHL-100R) HT

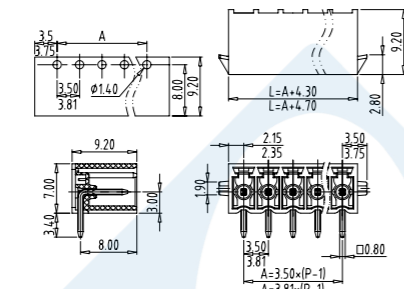

技术数据 Technical data	
Pitch (间距):	3.50mm(3.81mm)
Approval (认证):	UL, CE, RoHS, VDE(Applying)
Rated voltage (电压):	300V 320V
Rated current (电流):	13A 10A
PCB hole Dia(PCB 直径):	Φ 1.4mm

料号 Part Number	
极数 (Poles)	型号 (Model)
02	TLPHL-001R(TLPHL-100R)-02P-HT
:	:
24	TLPHL-001R(TLPHL-100R)-24P-HT

TLPHW-001R(TLPHW-100R) HT

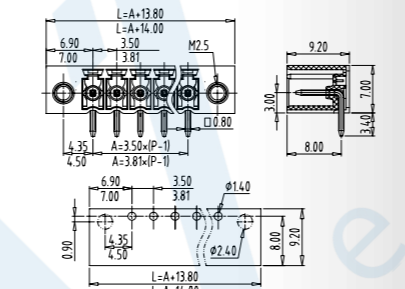

技术数据 Technical data	
Pitch (间距):	3.50mm(3.81mm)
Approval (认证):	UL, CE, RoHS, VDE(Applying)
Rated voltage (电压):	300V 320V
Rated current (电流):	13A 10A
PCB hole Dia(PCB 直径):	Φ 1.4mm

料号 Part Number	
极数 (Poles)	型号 (Model)
02	TLPHW-001R(TLPHW-100R)-02P-HT
:	:
24	TLPHW-001R(TLPHW-100R)-24P-HT

TLPH-200R(TLPH-300R) HT

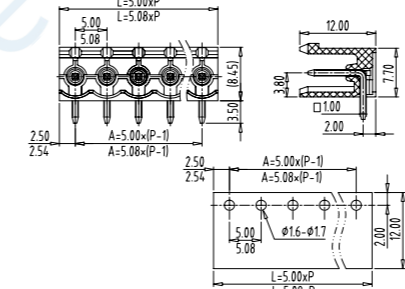

技术数据 Technical data	
Pitch (间距):	5.00mm(5.08mm)
Approval (认证):	UL, CE, RoHS, VDE(Applying)
Rated voltage (电压):	300V 630V
Rated current (电流):	16A 20A
PCB hole Dia(PCB 直径):	Φ 1.6-Φ 1.7mm

料号 Part Number	
极数 (Poles)	型号 (Model)
02	TLPH-200R(TLPH-300R)-02P-HT
:	:
24	TLPH-200R(TLPH-300R)-24P-HT

TLPHC-200R(TLPHC-300R) HT

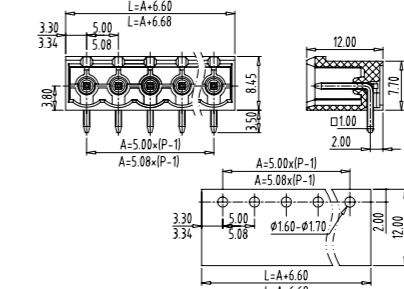

技术数据 Technical data	
Pitch (间距):	5.00mm(5.08mm)
Approval (认证):	UL, CE, RoHS, VDE(Applying)
Rated voltage (电压):	300V 630V
Rated current (电流):	16A 20A
PCB hole Dia(PCB 直径):	Φ 1.6-Φ 1.7mm

料号 Part Number	
极数 (Poles)	型号 (Model)
02	TLPHC-200R(TLPHC-300R)-02P-HT
:	:
24	TLPHC-200R(TLPHC-300R)-24P-HT

TLPHW-200R(TLPHW-300R) HT

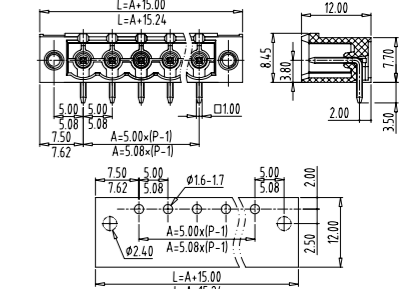

技术数据 Technical data	
Pitch (间距):	5.00mm(5.08mm)
Approval (认证):	UL, CE, RoHS, VDE(Applying)
Rated voltage (电压):	300V 630V
Rated current (电流):	16A 20A
PCB hole Dia(PCB 直径):	Φ 1.6-Φ 1.7mm

料号 Part Number	
极数 (Poles)	型号 (Model)
02	TLPHW-200R(TLPHW-300R)-02P-HT
:	:
24	TLPHW-200R(TLPHW-300R)-24P-HT

TLPHC-313V HT

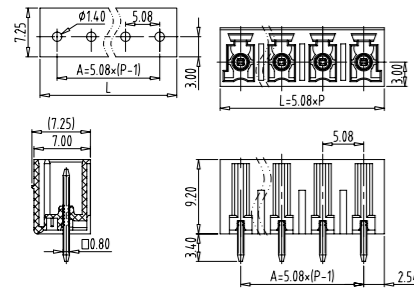

技术数据 Technical data	
Pitch (间距):	5.08mm
Approval (认证):	UL, VDE
Rated voltage (电压):	300V 630V
Rated current (电流):	13A 13A
PCB hole Dia(PCB直径):	Φ 1.4mm

料号 Part Number	
极数 (Poles)	型号 (Model)
02	TLPHC-313V-02P-HT
:	:
24	TLPHC-313V-24P-HT

TLPHW-313V HT

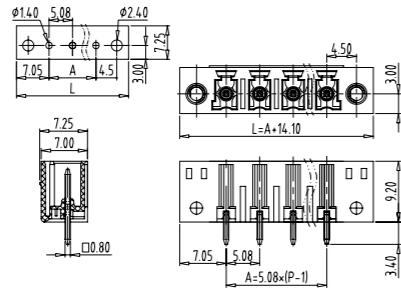

技术数据 Technical data	
Pitch (间距):	5.08mm
Approval (认证):	UL, VDE
Rated voltage (电压):	300V 630V
Rated current (电流):	13A 13A
PCB hole Dia(PCB直径):	Φ 1.4mm

料号 Part Number	
极数 (Poles)	型号 (Model)
02	TLPHW-313V-02P-HT
:	:
24	TLPHW-313V-24P-HT

TLPHC-313R HT

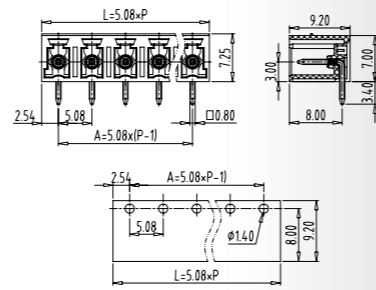

技术数据 Technical data	
Pitch (间距):	5.08mm
Approval (认证):	UL, VDE
Rated voltage (电压):	300V 630V
Rated current (电流):	13A 13A
PCB hole Dia(PCB直径):	Φ 1.4mm

料号 Part Number	
极数 (Poles)	型号 (Model)
02	TLPHC-313R-02P-HT
:	:
24	TLPHC-313R-24P-HT

TLPHDL-020V HT

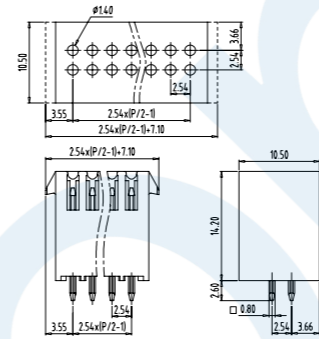

技术数据 Technical data	
Pitch (间距):	2.54mm
Approval (认证):	UL(Applying) VDE(Applying)
Rated voltage (电压):	150V 160V
Rated current (电流):	5A 6A
PCB hole Dia(PCB直径):	Φ 1.40mm

料号 Part Number	
极数 (Poles)	型号 (Model)
04	TLPHDL-020V-04P-HT
:	:
48	TLPHDL-020V-48P-HT

TLPHDC-020R HT

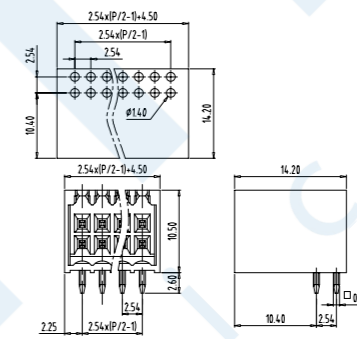

技术数据 Technical data	
Pitch (间距):	2.54mm
Approval (认证):	UL(Applying) VDE(Applying)
Rated voltage (电压):	150V 160V
Rated current (电流):	5A 6A
PCB hole Dia(PCB直径):	Φ 1.40mm

料号 Part Number	
极数 (Poles)	型号 (Model)
04	TLPHDC-020R-04P-HT
:	:
48	TLPHDC-020R-48P-HT

TLPHDW-020R HT

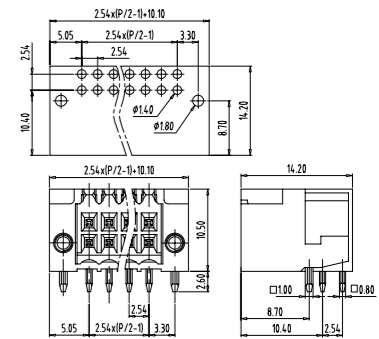

技术数据 Technical data	
Pitch (间距):	2.54mm
Approval (认证):	UL(Applying) VDE(Applying)
Rated voltage (电压):	150V 160V
Rated current (电流):	5A 6A
PCB hole Dia(PCB直径):	Φ 1.40mm

料号 Part Number	
极数 (Poles)	型号 (Model)
04	TLPHDW-020R-04P-HT
:	:
48	TLPHDW-020R-48P-HT

TLPHW-313R HT

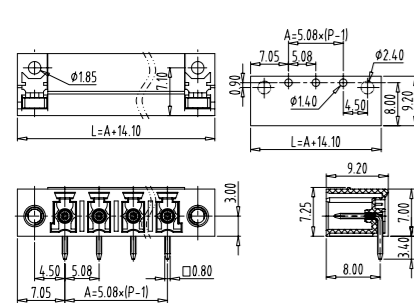

技术数据 Technical data	
Pitch (间距):	5.08mm
Approval (认证):	UL, VDE
Rated voltage (电压):	300V 630V
Rated current (电流):	13A 13A
PCB hole Dia(PCB直径):	Φ 1.4mm

料号 Part Number	
极数 (Poles)	型号 (Model)
02	TLPHW-313R-02P-HT
:	:
24	TLPHW-313R-24P-HT

TLPHDC-020V HT

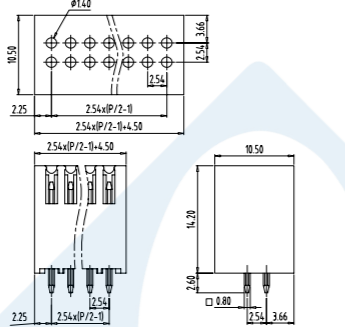

技术数据 Technical data	
Pitch (间距):	2.54mm
Approval (认证):	UL(Applying) VDE(Applying)
Rated voltage (电压):	150V 320V
Rated current (电流):	5A 6A
PCB hole Dia(PCB直径):	Φ 1.40mm

料号 Part Number	
极数 (Poles)	型号 (Model)
04	TLPHDC-020V-04P-HT
:	:
48	TLPHDC-020V-48P-HT

TLPHDW-020V HT

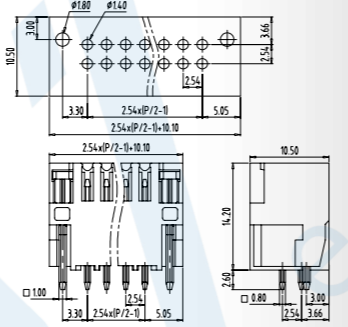
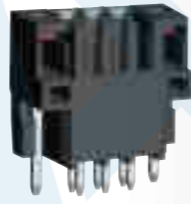

技术数据 Technical data	
Pitch (间距):	2.54mm
Approval (认证):	UL(Applying) VDE(Applying)
Rated voltage (电压):	150V 320V
Rated current (电流):	5A 6A
PCB hole Dia(PCB直径):	Φ 1.40mm

料号 Part Number	
极数 (Poles)	型号 (Model)
04	TLPHDW-020V-04P-HT
:	:
48	TLPHDW-020V-48P-HT

TLPHDL-020R HT

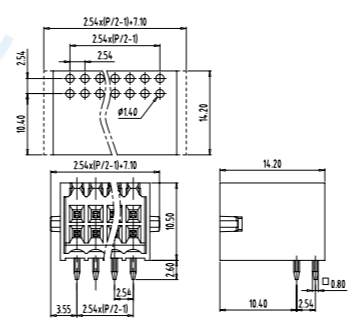

技术数据 Technical data	
Pitch (间距):	2.54mm
Approval (认证):	UL(Applying) VDE(Applying)
Rated voltage (电压):	150V 160V
Rated current (电流):	5A 6A
PCB hole Dia(PCB直径):	Φ 1.40mm

料号 Part Number	
极数 (Poles)	型号 (Model)
04	TLPHDL-020R-04P-HT
:	:
48	TLPHDL-020R-48P-HT

TLPHDC-007V HT

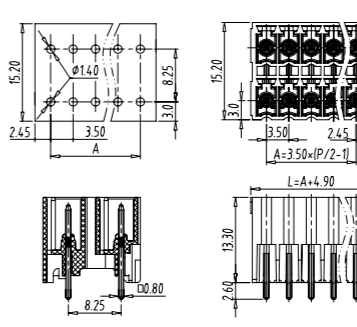

技术数据 Technical data	
Pitch (间距):	3.50mm
Approval (认证):	UL, VDE
Rated voltage (电压):	300V 160V
Rated current (电流):	8A 10A
PCB hole Dia(PCB直径):	Φ 1.4mm

料号 Part Number	
极数 (Poles)	型号 (Model)
04	TLPHDC-007V-04P-HT
:	:
48	TLPHDC-007V-48P-HT

TLPHDL-007V HT

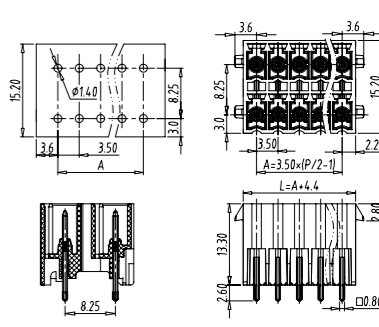

技术数据 Technical data	
Pitch (间距):	3.50mm
Approval (认证):	UL, VDE
Rated voltage (电压):	300V 160V
Rated current (电流):	8A 10A
PCB hole Dia(PCB直径):	Φ 1.4mm

料号 Part Number	
极数 (Poles)	型号 (Model)
04	TLPHDL-007V-04P-HT
:	:
48	TLPHDL-007V-48P-HT

TLPHDC-007R HT

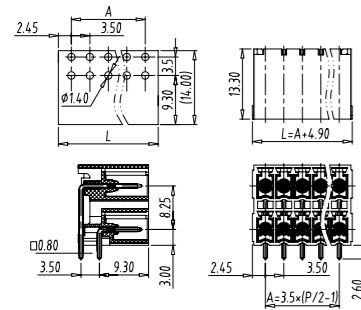

技术数据 Technical data	
Pitch (间距):	3.50mm
Approval (认证):	UL, CE, Ex, SR, CQC
Rated voltage (电压):	300V 160V
Rated current (电流):	8A 10A
PCB hole Dia(PCB直径):	Φ 1.4mm

料号 Part Number	
极数 (Poles)	型号 (Model)
04	TLPHDC-007R-04P-HT
:	:
48	TLPHDC-007R-48P-HT

TLPHDL-007R HT

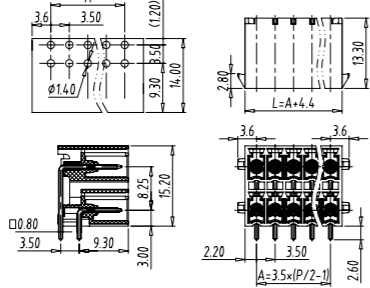

技术数据 Technical data	
Pitch (间距):	3.50mm
Approval (认证):	UL, CE, Ex, SR, CQC
Rated voltage (电压):	300V 160V
Rated current (电流):	8A 10A
PCB hole Dia(PCB直径):	Φ 1.4mm

料号 Part Number	
极数 (Poles)	型号 (Model)
04	TLPHDL-007R-04P-HT
:	:
48	TLPHDL-007R-48P-HT

TLPHDC-010V HT

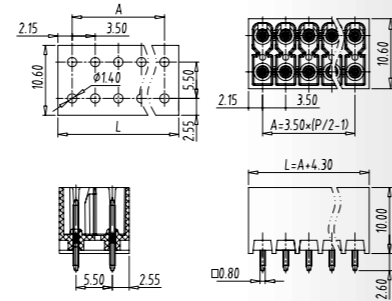

技术数据 Technical data	
Pitch (间距):	3.50mm
Approval (认证):	UL, CE, Ex, SR, CQC
Rated voltage (电压):	300V 160V
Rated current (电流):	8A 10A
PCB hole Dia(PCB直径):	Φ 1.4mm

料号 Part Number	
极数 (Poles)	型号 (Model)
04	TLPHDC-010V-04P-HT
:	:
48	TLPHDC-010V-48P-HT

TLPHDW-010V HT

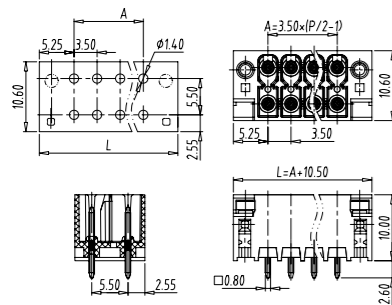

技术数据 Technical data	
Pitch (间距):	3.50mm
Approval (认证):	UL, CE, Ex, SR, CQC
Rated voltage (电压):	300V 160V
Rated current (电流):	8A 10A
PCB hole Dia(PCB直径):	Φ 1.4mm

料号 Part Number	
极数 (Poles)	型号 (Model)
04	TLPHDW-010V-04P-HT
:	:
48	TLPHDW-010V-48P-HT

TLPHDC-010R HT

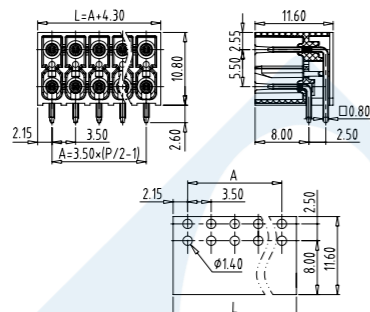

技术数据 Technical data	
Pitch (间距):	3.50mm
Approval (认证):	UL, CE, Ex, SR, CQC
Rated voltage (电压):	300V 160V
Rated current (电流):	8A 10A
PCB hole Dia(PCB直径):	Φ 1.4mm

料号 Part Number	
极数 (Poles)	型号 (Model)
04	TLPHDC-010R-04P-HT
:	:
48	TLPHDC-010R-48P-HT

TLPHDW-010R HT

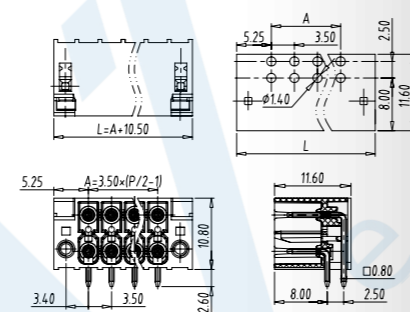

技术数据 Technical data	
Pitch (间距):	3.50mm
Approval (认证):	UL, CE, Ex, SR, CQC
Rated voltage (电压):	300V 160V
Rated current (电流):	8A 10A
PCB hole Dia(PCB直径):	Φ 1.4mm

料号 Part Number	
极数 (Poles)	型号 (Model)
04	TLPHDW-010R-04P-HT
:	:
48	TLPHDW-010R-48P-HT

TLPCK-001-S

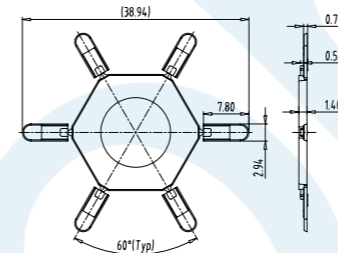

适用产品 Applicable product	
TLPHC/W/L-001 (TLPHC/W/L-100)	
TLPHC/W-004 (TLPHC/W-104)	
TLPHDC/W-005 (TLPHC/W-105)	
TLPHDC/W/L-007	
TLPHDC/W-008 (TLPHDC/W-108)	
TLPHS-100	
TLPHS (W/WA)-112	
TLPHC/W-313	

TLPCK-002-S

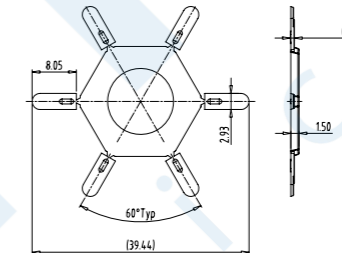
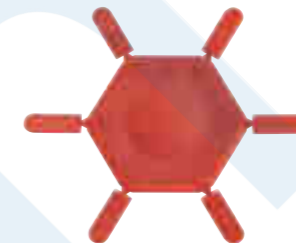

适用产品 Applicable product	
TLPS(W)-200/300/400/500	
TLPS(W)-207	
TLPS(W)-214	
TLPS(W)-215/301	
TLPS(W)-305	
TLPS(W)-201/302	
TLPS(W)-308	
TLPS(W)-309	
TLPS(W)-312	
TLPS(W)-502	

TLPCK-003-S

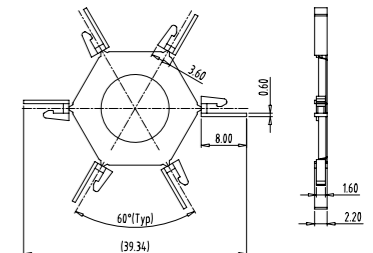
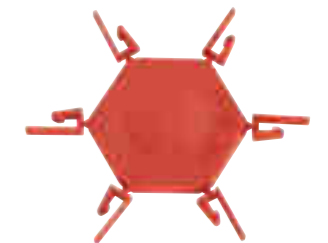

适用产品 Applicable product	
TLPH(C/W)-200/300/400/500	
TLPHDC/W-200	
TLPH-201	
TLPHD(C/W)-203/303	
TLPHS(W/WA)-304	
TLPHW-306	

TLPCK-004-S

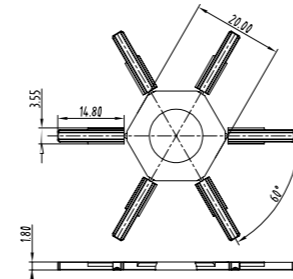

适用产品 Applicable product	
TLPS(W)-501	
TLPHC(W)-501	
TLPS(W)-516	
TLPHC(W)-516	
TLPS(W)-800	
TLPHC(W)-800	

TLPCK-006-S

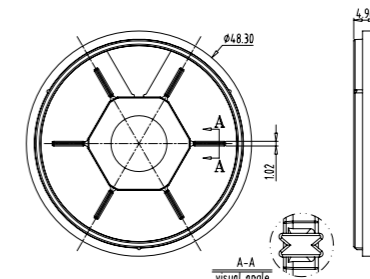

适用产品 Applicable product	
TLPSD(W/L)-010	
TLPHDC(W)-010	

TLC SERIES – Spring-cage Clamp Terminal Block

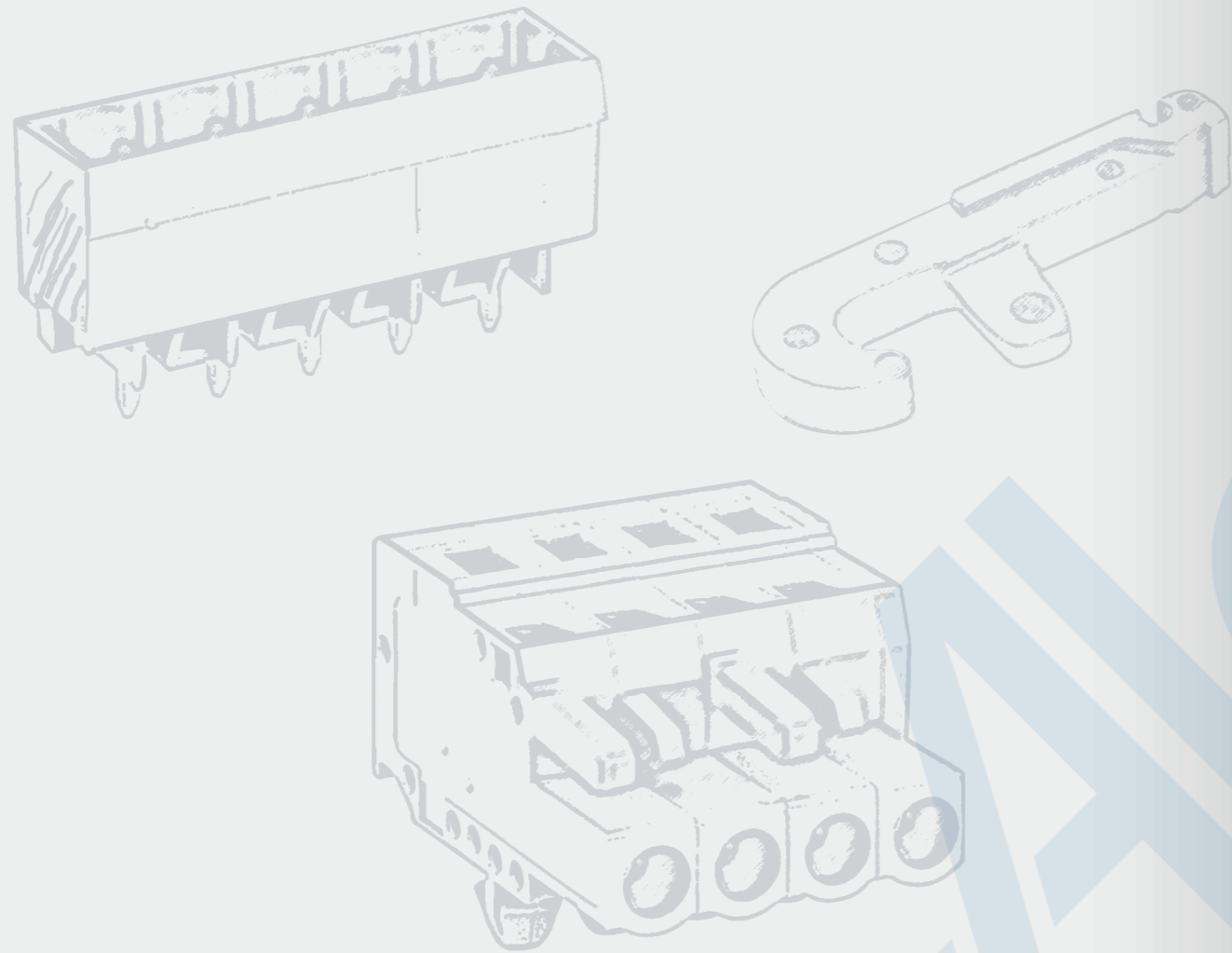

How to order

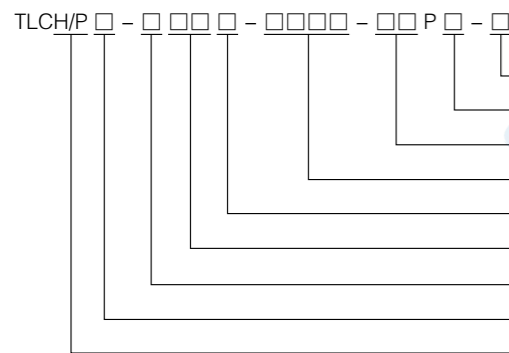

- Color: M=Gray, A=Orange
- 5=Double pitch, None=Standard pitch
- Poles
- Special code
- V=180°, R=90°(A=against mismatch, F=with snap-in mounting feet)
- Series number
- Pitch: 0=2.50 or 3.50, 2=5.0, 3=5.08, 4=7.5, 5=7.62
- M=With fixing hole, W=with flange, L=with locking levers
- H=male headers, P=female plugs

TLCH-002V

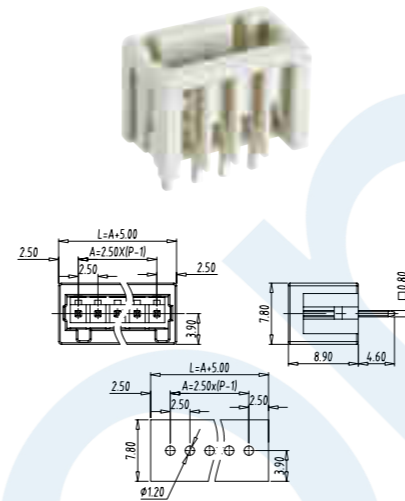

技术数据 Technical data	
Pitch (间距):	2.50mm
Approval (认证):	VDE (Applying)
Rated voltage (电压):	150V 160V
Rated current (电流):	4A 6A
PCB hole Dia(PCB直径):	Φ 1.2mm
料号 Part Number	
极数 (Poles)	型号 (Model)
02	TLCH-002V-02P
:	:
24	TLCH-002V-24P

TLCH-002R

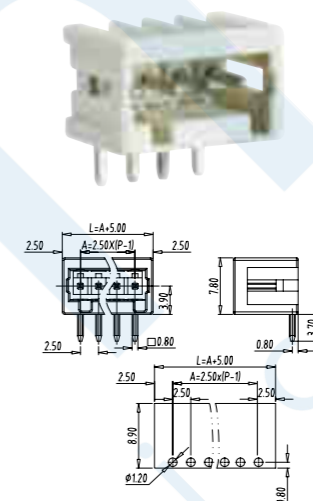

技术数据 Technical data	
Pitch (间距):	2.50mm
Approval (认证):	VDE (Applying)
Rated voltage (电压):	150V 160V
Rated current (电流):	4A 6A
PCB hole Dia(PCB直径):	Φ 1.2mm
料号 Part Number	
极数 (Poles)	型号 (Model)
02	TLCH-002R-02P
:	:
24	TLCH-002R-24P

TLCH-001V(TLCH-100V)

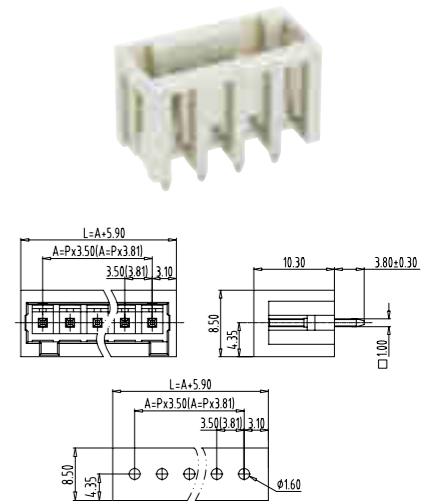

技术数据 Technical data	
Pitch (间距):	3.50mm (3.81mm)
Approval (认证):	VDE (Applying)
Rated voltage (电压):	300V 160V
Rated current (电流):	12A 10A
PCB hole Dia(PCB直径):	Φ 1.6mm
料号 Part Number	
极数 (Poles)	型号 (Model)
02	TLCH-001V-02P(TLCH-100V-02P)
:	:
24	TLCH-001V-24P(TLCH-100V-24P)

TLCH-001R(TLCH-100R)

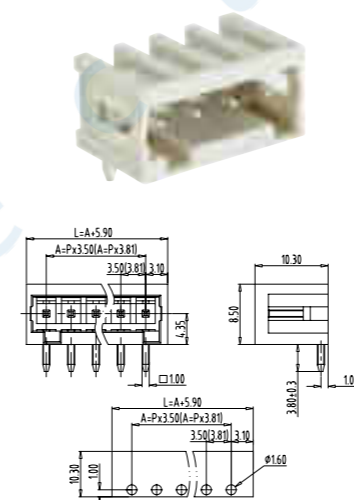

技术数据 Technical data	
Pitch (间距):	3.50mm (3.81mm)
Approval (认证):	VDE (Applying)
Rated voltage (电压):	300V 160V
Rated current (电流):	12A 10A
PCB hole Dia(PCB直径):	Φ 1.6mm
料号 Part Number	
极数 (Poles)	型号 (Model)
02	TLCH-001R-02P(TLCH-100R-02P)
:	:
24	TLCH-001R-24P(TLCH-100R-24P)

TLCH-200V(TLCH-300V)

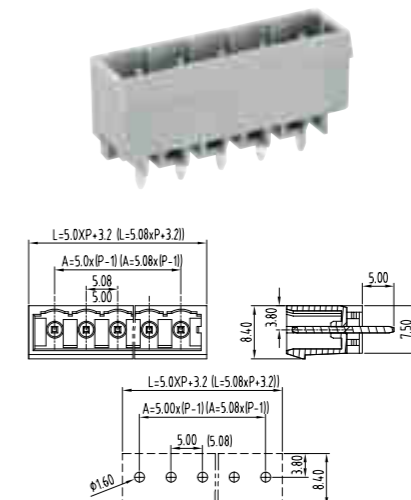

技术数据 Technical data	
Pitch (间距):	5.00mm(5.08mm)
Approval (认证):	VDE (Applying)
Rated voltage (电压):	300V 320V
Rated current (电流):	16A 16A
PCB hole Dia(PCB直径):	Φ 1.6mm
料号 Part Number	
极数 (Poles)	型号 (Model)
02	TLCH-200V-02P(TLCH-300V-02P)
:	:
24	TLCH-200V-24P(TLCH-300V-24P)

TLCH-200VA

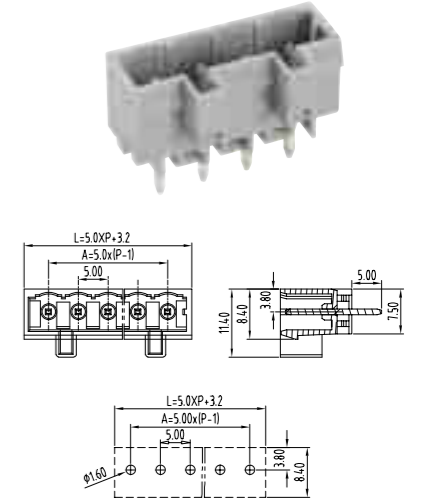

技术数据 Technical data	
Pitch (间距):	5.00mm
Approval (认证):	VDE (Applying)
Rated voltage (电压):	300V 320V
Rated current (电流):	16A 16A
PCB hole Dia(PCB直径):	Φ 1.6
料号 Part Number	
极数 (Poles)	型号 (Model)
02	TLCH-200VA-02P
:	:
24	TLCH-200VA-24P

TLCHM-200V(TLCHM-300V)

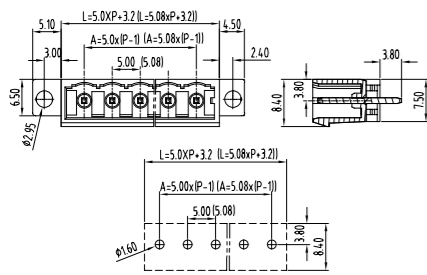
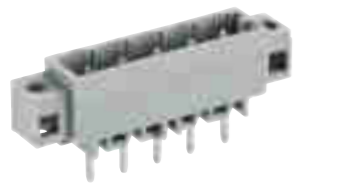

技术数据 Technical data	
Pitch (间距):	5.00mm(5.08mm)
Approval (认证):	
Rated voltage (电压):	300V 320V
Rated current (电流):	16A 16A
PCB hole Dia(PCB 直径):	Φ 1.6

料号 Part Number	
极数 (Poles)	型号 (Model)
02	TLCHM-200V-02P(TLCHM-300V-02P)
:	:
24	TLCHM-200V-24P (TLCHM-300V-24P)

TLCHM-200VA

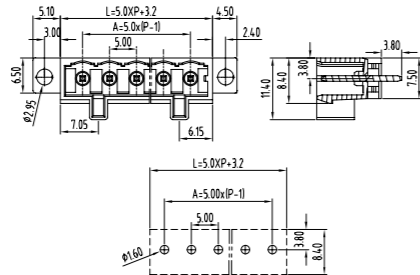
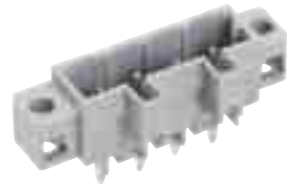

技术数据 Technical data	
Pitch (间距):	5.00mm
Approval (认证):	
Rated voltage (电压):	300V 320V
Rated current (电流):	16A 16A
PCB hole Dia(PCB 直径):	Φ 1.6

料号 Part Number	
极数 (Poles)	型号 (Model)
02	TLCHM-200VA-02P
:	:
24	TLCHM-200VA-24P

TLCH-200R(TLCH-300R)

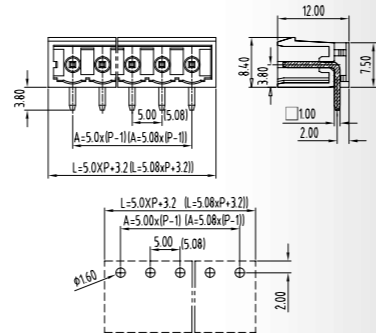

技术数据 Technical data	
Pitch (间距):	5.00mm(5.08mm)
Approval (认证):	
Rated voltage (电压):	300V 320V
Rated current (电流):	16A 16A
PCB hole Dia(PCB 直径):	Φ 1.6

料号 Part Number	
极数 (Poles)	型号 (Model)
02	TLCH-200R-02P(TLCH-300R-02P)
:	:
24	TLCH-200R-24P(TLCH-300R-24P)

TLCH-400V(TLCH-500V)

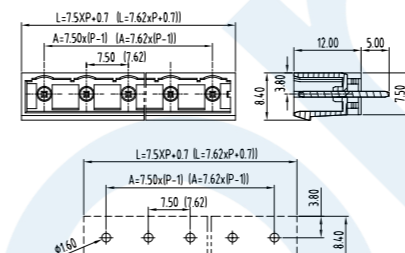

技术数据 Technical data	
Pitch (间距):	7.50mm (7.62mm)
Approval (认证):	
Rated voltage (电压):	300V 630V
Rated current (电流):	16A 16A
PCB hole Dia(PCB 直径):	Φ 1.6

料号 Part Number	
极数 (Poles)	型号 (Model)
02	TLCH-400V-02P(TLCH-500V-02P)
:	:
12	TLCH-400V-12P(TLCH-500V-12P)

TLCH-400VA

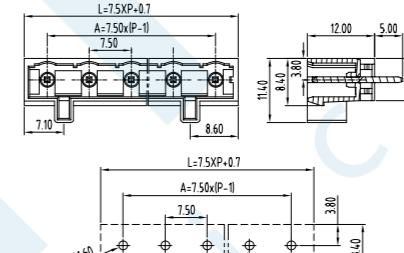

技术数据 Technical data	
Pitch (间距):	7.50mm
Approval (认证):	
Rated voltage (电压):	300V 630V
Rated current (电流):	16A 16A
PCB hole Dia(PCB 直径):	Φ 1.6

料号 Part Number	
极数 (Poles)	型号 (Model)
02	TLCH-400VA-02P
:	:
12	TLCH-400VA-12P

TLCHM-400V(TLCHM-500V)

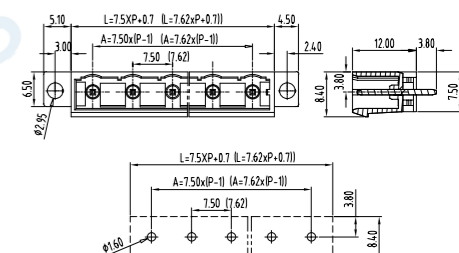

技术数据 Technical data	
Pitch (间距):	7.50mm (7.62mm)
Approval (认证):	
Rated voltage (电压):	300V 630V
Rated current (电流):	16A 16A
PCB hole Dia(PCB 直径):	Φ 1.6

料号 Part Number	
极数 (Poles)	型号 (Model)
02	TLCHM-400V-02P(TLCHM-500V-02P)
:	:
12	TLCHM-400V-12P(TLCHM-500V-12P)

TLCH-200RA

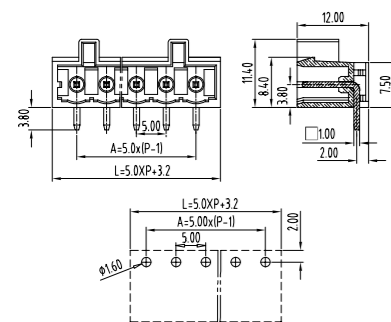
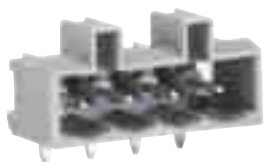

技术数据 Technical data	
Pitch (间距):	5.00mm
Approval (认证):	
Rated voltage (电压):	300V 320V
Rated current (电流):	16A 16A
PCB hole Dia(PCB 直径):	Φ 1.6

料号 Part Number	
极数 (Poles)	型号 (Model)
02	TLCH-200RA-02P
:	:
24	TLCH-200RA-24P

TLCHM-200R(TLCHM-300R)

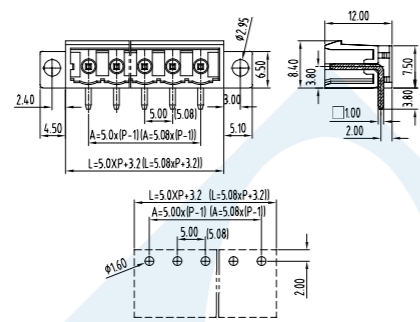
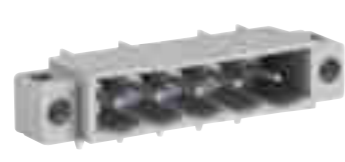

技术数据 Technical data	
Pitch (间距):	5.00mm(5.08mm)
Approval (认证):	
Rated voltage (电压):	300V 320V
Rated current (电流):	16A 16A
PCB hole Dia(PCB 直径):	Φ 1.6

料号 Part Number	
极数 (Poles)	型号 (Model)
02	TLCHM-200R-02P(TLCHM-300R-02P)
:	:
24	TLCHM-200R-24P(TLCHM-300R-24P)

TLCHW-300V

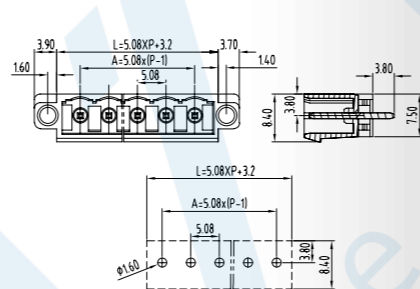
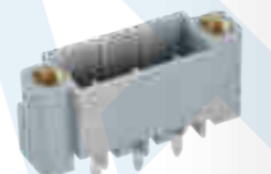

技术数据 Technical data	
Pitch (间距):	5.08mm
Approval (认证):	
Rated voltage (电压):	300V 320V
Rated current (电流):	16A 16A
PCB hole Dia(PCB 直径):	Φ 1.6

料号 Part Number	
极数 (Poles)	型号 (Model)
02	TLCHM-300V-02P
:	:
24	TLCHM-300V-24P

TLCHM-400VA

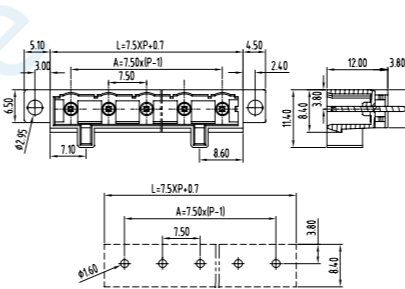

技术数据 Technical data	
Pitch (间距):	7.50mm
Approval (认证):	
Rated voltage (电压):	300V 630V
Rated current (电流):	16A 16A
PCB hole Dia(PCB 直径):	Φ 1.6

料号 Part Number	
极数 (Poles)	型号 (Model)
02	TLCHM-400VA-02P
:	:
12	TLCHM400VA-12P

TLCH-400R(TLCH-500R)

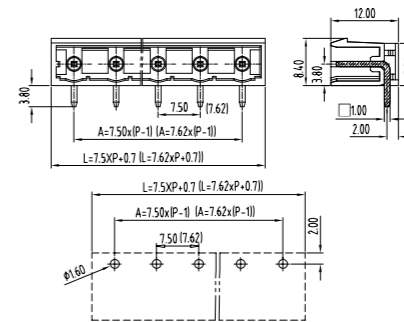

技术数据 Technical data	
Pitch (间距):	7.50mm (7.62mm)
Approval (认证):	
Rated voltage (电压):	300V 630V
Rated current (电流):	16A 16A
PCB hole Dia(PCB 直径):	Φ 1.6

料号 Part Number	
极数 (Poles)	型号 (Model)
02	TLCH-400R-02P(TLCH-500R-02P)
:	:
12	TLCH-400R-12P(TLCH-500R-12P)

TLCH-400RA

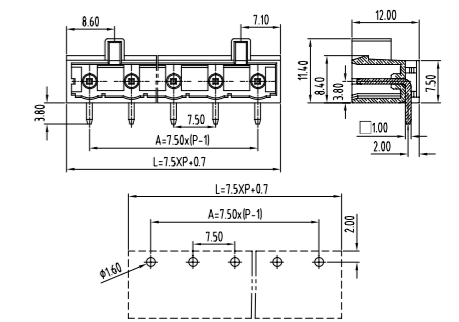

技术数据 Technical data	
Pitch (间距):	7.50mm
Approval (认证):	
Rated voltage (电压):	300V 630V
Rated current (电流):	16A 16A
PCB hole Dia(PCB 直径):	Φ 1.6

料号 Part Number	
极数 (Poles)	型号 (Model)
02	TLCH-400RA-02P
:	:
12	TLCH-400RA-12P

TLCHM-400R(TLCHM-500R)

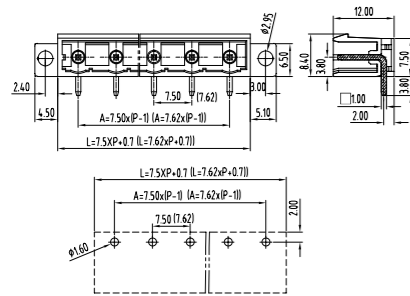

技术数据 Technical data	
Pitch (间距):	7.50mm (7.62mm)
Approval (认证):	UL, CE
Rated voltage (电压):	300V 630V
Rated current (电流):	16A 16A
PCB hole Dia(PCB直径):	Φ 1.6

料号 Part Number	
极数 (Poles)	型号 (Model)
02	TLCHM-400R-02P(TLCHM-500R-02P)
:	:
12	TLCHM-400R-12P(TLCHM-500R-12P)

TLCP-002

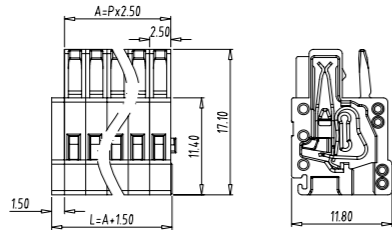

技术数据 Technical data	
Pitch (间距):	2.50mm
Approval (认证):	UL (Applying)
Rated voltage (电压):	150V
Rated current (电流):	4A
Wire range (线径):	28-20AWG

料号 Part Number	
极数 (Poles)	型号 (Model)
02	TLCP-002-02P
:	:
24	TLCP-002-24P

TLCP-001(TLCP-100)

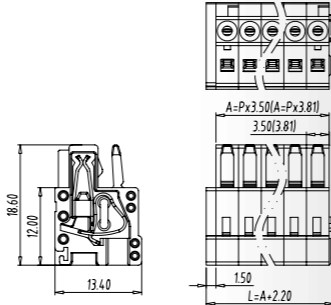

技术数据 Technical data	
Pitch (间距):	3.50mm (3.81mm)
Approval (认证):	UL, CE
Rated voltage (电压):	300V 160V
Rated current (电流):	12A 10A
Wire range (线径):	28-14AWG 0.2-1.5mm ²

料号 Part Number	
极数 (Poles)	型号 (Model)
02	TLCP-001-02P(TLCP-100-02P)
:	:
24	TLCP-001-24P(TLCP-100-24P)

TLCP-200F(TLCP-300F)

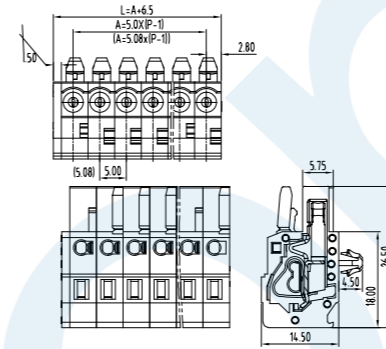

技术数据 Technical data	
Pitch (间距):	5.00mm (5.08mm)
Approval (认证):	UL, CE
Rated voltage (电压):	300V 320V
Rated current (电流):	16A 16A
Wire range (线径):	12-28AWG 0.2-2.5mm ²

料号 Part Number	
极数 (Poles)	型号 (Model)
02	TLCP-200F-02P(TLCP-300F-02P)
:	:
24	TLCP-200F-24P(TLCP-300F-24P)

TLCP-200FA

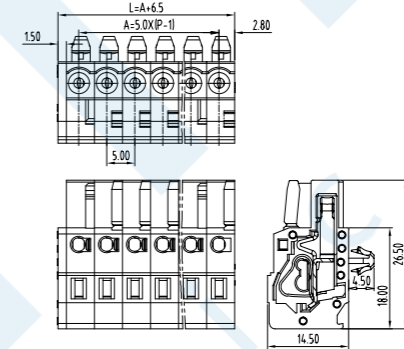
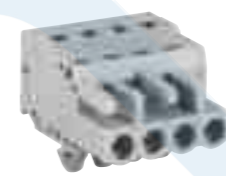

技术数据 Technical data	
Pitch (间距):	5.00mm
Approval (认证):	UL, CE
Rated voltage (电压):	300V 320V
Rated current (电流):	16A 16A
Wire range (线径):	12-28AWG 0.2-2.5mm ²

料号 Part Number	
极数 (Poles)	型号 (Model)
02	TLCP-200FA-02P
:	:
24	TLCP-200FA-24P

TLCPM-200(TLCPM-300)

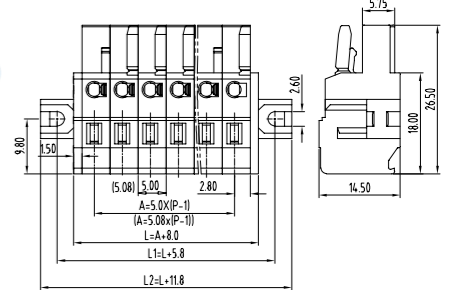
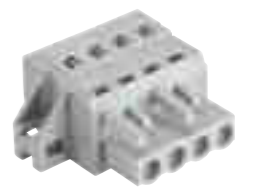

技术数据 Technical data	
Pitch (间距):	5.00mm (5.08mm)
Approval (认证):	UL, CE
Rated voltage (电压):	300V 320V
Rated current (电流):	16A 16A
Wire range (线径):	12-28AWG 0.2-2.5mm ²

料号 Part Number	
极数 (Poles)	型号 (Model)
02	TLCPM-200-02P(TLCPM-300-02P)
:	:
24	TLCPM-200-24P(TLCPM-300-24P)

TLCPL-001(TLCPL-100)

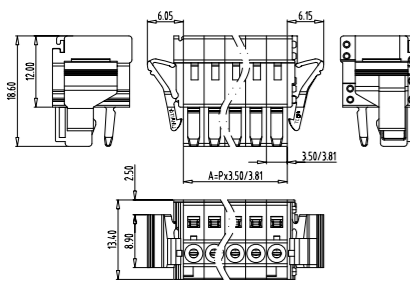

技术数据 Technical data	
Pitch (间距):	3.50mm (3.81mm)
Approval (认证):	UL, CE
Rated voltage (电压):	300V 160V
Rated current (电流):	12A 10A
Wire range (线径):	28-14AWG 0.2-1.5mm ²

料号 Part Number	
极数 (Poles)	型号 (Model)
02	TLCPL-001/100-02P
:	:
24	TLCPL-001/100-24P

TLCP-200(TLCP-300)

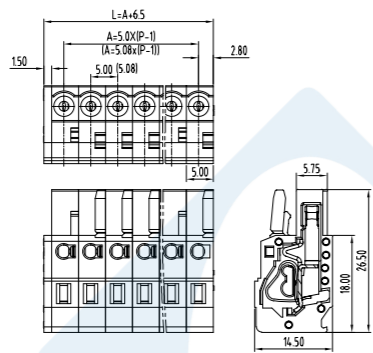

技术数据 Technical data	
Pitch (间距):	5.00mm (5.08mm)
Approval (认证):	UL, CE
Rated voltage (电压):	300V 320V
Rated current (电流):	16A 16A
Wire range (线径):	12-28AWG 0.2-2.5mm ²

料号 Part Number	
极数 (Poles)	型号 (Model)
02	TLCP-200-02P(TLCP-300-02P)
:	:
24	TLCP-200-24P(TLCP-300-24P)

TLCP-200A

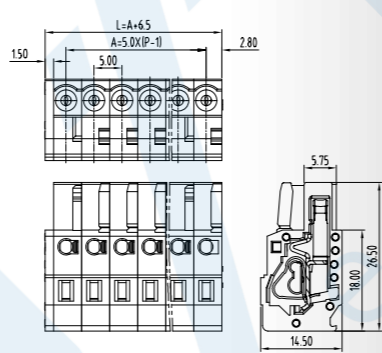

技术数据 Technical data	
Pitch (间距):	5.00mm
Approval (认证):	UL, CE
Rated voltage (电压):	300V 320V
Rated current (电流):	16A 16A
Wire range (线径):	12-28AWG 0.2-2.5mm ²

料号 Part Number	
极数 (Poles)	型号 (Model)
02	TLCP-200A-02P
:	:
24	TLCP-200A-24P

TLCPM-200A

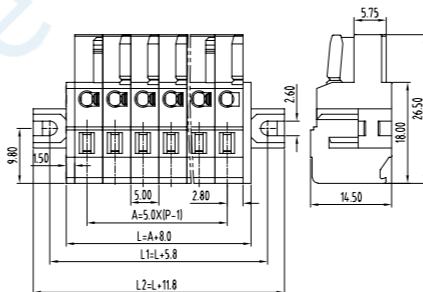
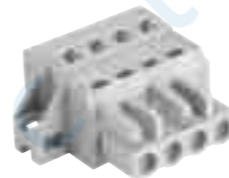

技术数据 Technical data	
Pitch (间距):	5.00mm
Approval (认证):	UL, CE
Rated voltage (电压):	300V 320V
Rated current (电流):	16A 16A
Wire range (线径):	12-28AWG 0.2-2.5mm ²

料号 Part Number	
极数 (Poles)	型号 (Model)
02	TLCPM-200A-02P
:	:
24	TLCPM-200A-24P

TLCPL-200(TLCPL-300)

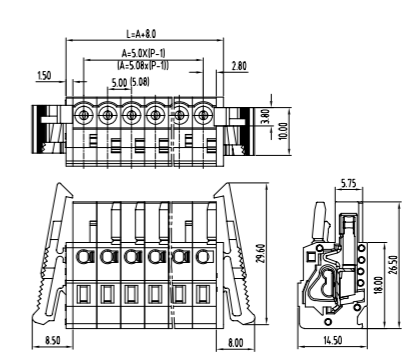

技术数据 Technical data	
Pitch (间距):	5.00mm (5.08mm)
Approval (认证):	UL, CE
Rated voltage (电压):	300V 320V
Rated current (电流):	16A 16A
Wire range (线径):	12-28AWG 0.2-2.5mm ²

料号 Part Number	
极数 (Poles)	型号 (Model)
02	TLCPL-200-02P(TLCPL-300-02P)
:	:
24	TLCPL-200-24P(TLCPL-300-24P)

TLCPL-200A

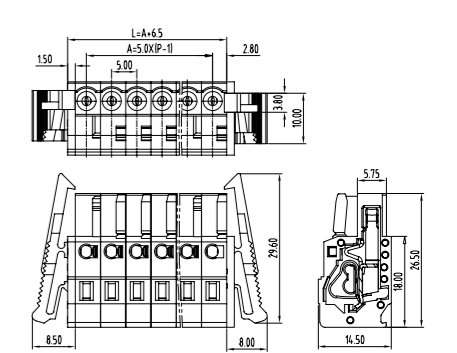

技术数据 Technical data	
Pitch (间距):	5.00mm
Approval (认证):	UL, CE
Rated voltage (电压):	300V 320V
Rated current (电流):	16A 16A
Wire range (线径):	12-28AWG 0.2-2.5mm ²

料号 Part Number	
极数 (Poles)	型号 (Model)
02	TLCPL-200A-02P
:	:
24	TLCPL-200A-24P

TLCPW-300

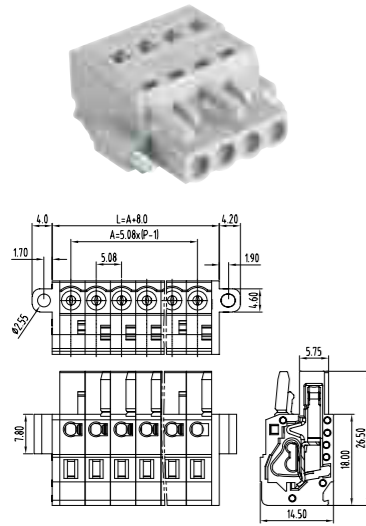

技术数据 Technical data	
Pitch (间距):	5.08mm
Approval (认证):	UL, CE
Rated voltage (电压):	300V 320V
Rated current (电流):	16A 16A
Wire range (线径):	12-28AWG 0.2-2.5mm ²
料号 Part Number	
极数 (Poles)	型号 (Model)
02	TLCPW-300-02P
:	:
24	TLCPW-300-24P

TLCP-400(TLCP-500)

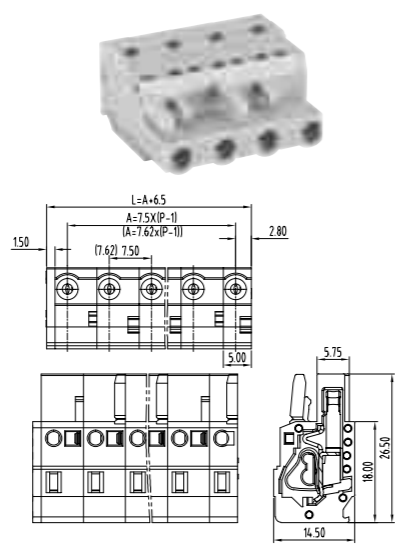

技术数据 Technical data	
Pitch (间距):	7.50mm (7.62mm)
Approval (认证):	UL, CE
Rated voltage (电压):	300V 630V
Rated current (电流):	16A 16A
Wire range (线径):	12-28AWG 0.2-2.5mm ²
料号 Part Number	
极数 (Poles)	型号 (Model)
02	TLCP-400F-02P(TLCP-500F-02P)
:	:
12	TLCP-400F-12P(TLCP-500F-12P)

TLCP-400A

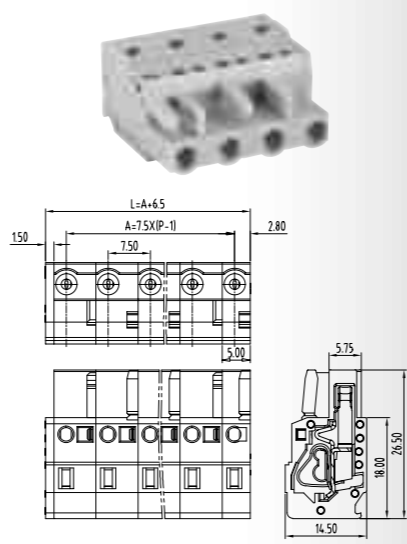

技术数据 Technical data	
Pitch (间距):	7.50mm
Approval (认证):	UL, CE
Rated voltage (电压):	300V 630V
Rated current (电流):	16A 16A
Wire range (线径):	12-28AWG 0.2-2.5mm ²
料号 Part Number	
极数 (Poles)	型号 (Model)
02	TLCP-400A-02P
:	:
12	TLCP-400A-12P

TLCPM-400A

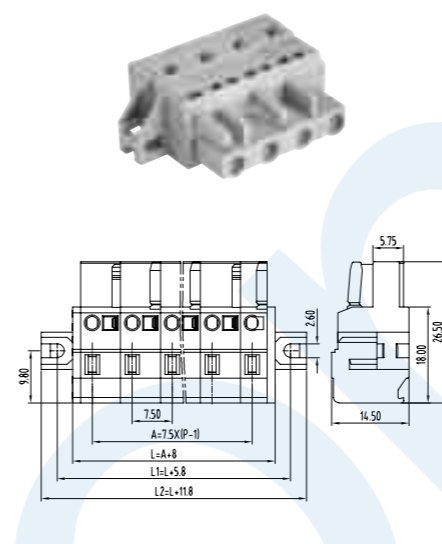

技术数据 Technical data	
Pitch (间距):	7.50mm
Approval (认证):	UL, CE
Rated voltage (电压):	300V 630V
Rated current (电流):	16A 16A
Wire range (线径):	12-28AWG 0.2-2.5mm ²
料号 Part Number	
极数 (Poles)	型号 (Model)
02	TLCPM-400A-02P
:	:
12	TLCPM-400A-12P

TLCPL-400(TLCPL-500)

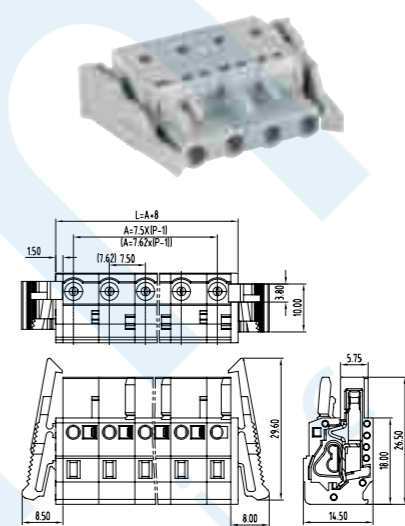

技术数据 Technical data	
Pitch (间距):	7.50mm (7.62mm)
Approval (认证):	UL, CE
Rated voltage (电压):	300V 630V
Rated current (电流):	16A 16A
Wire range (线径):	12-28AWG 0.2-2.5mm ²
料号 Part Number	
极数 (Poles)	型号 (Model)
02	TLCPL-400-02P(TLCPL-500-02P)
:	:
12	TLCPL-400-12P(TLCPL-500-12P)

TLCPL-400A

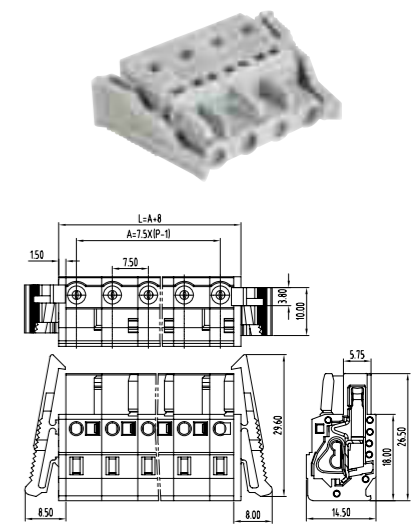

技术数据 Technical data	
Pitch (间距):	7.50mm
Approval (认证):	UL, CE
Rated voltage (电压):	300V 630V
Rated current (电流):	16A 16A
Wire range (线径):	12-28AWG 0.2-2.5mm ²
料号 Part Number	
极数 (Poles)	型号 (Model)
02	TLCPL-400A-02P
:	:
12	TLCPL-400A-12P

TLCP-400F(TLCP-500F)

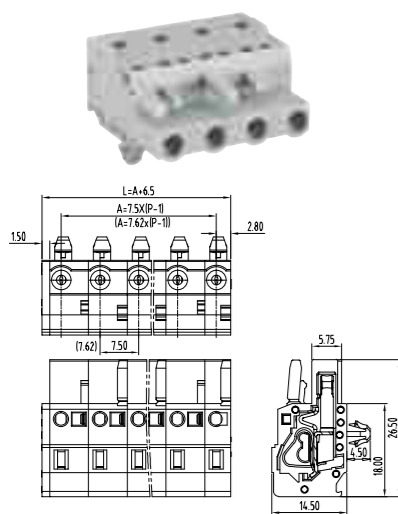

技术数据 Technical data	
Pitch (间距):	7.50mm (7.62mm)
Approval (认证):	UL, CE
Rated voltage (电压):	300V 630V
Rated current (电流):	16A 16A
Wire range (线径):	12-28AWG 0.2-2.5mm ²
料号 Part Number	
极数 (Poles)	型号 (Model)
02	TLCP-400F-02P(TLCP-500F-02P)
:	:
12	TLCP-400F-12P(TLCP-500F-12P)

TLCP-400FA

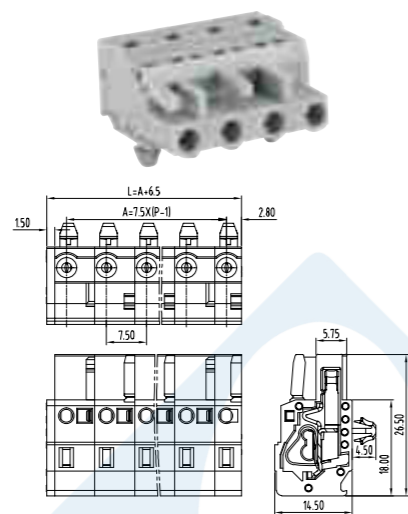

技术数据 Technical data	
Pitch (间距):	7.50mm
Approval (认证):	UL, CE
Rated voltage (电压):	300V 630V
Rated current (电流):	16A 16A
Wire range (线径):	12-28AWG 0.2-2.5mm ²
料号 Part Number	
极数 (Poles)	型号 (Model)
02	TLCP-400FA-02P
:	:
12	TLCP-400FA-12P

TLCPM-400(TLCPM-500)

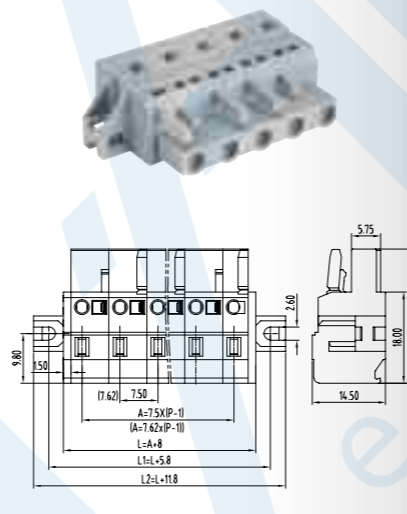

技术数据 Technical data	
Pitch (间距):	7.50mm (7.62mm)
Approval (认证):	UL, CE
Rated voltage (电压):	300V 630V
Rated current (电流):	16A 16A
Wire range (线径):	12-28AWG 0.2-2.5mm ²
料号 Part Number	
极数 (Poles)	型号 (Model)
02	TLCPM-400-02P(TLCPM-500-02P)
:	:
12	TLCPM-400-12P(TLCPM-500-12P)

TLCHP-003

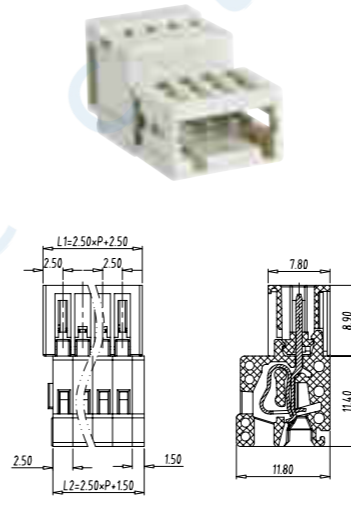

技术数据 Technical data	
Pitch (间距):	2.50mm
Approval (认证):	UL, VDE(Applying)
Rated voltage (电压):	150V 160V
Rated current (电流):	4A 6A
Wire range (线径):	28-20AWG 0.2-0.5mm ²
料号 Part Number	
极数 (Poles)	型号 (Model)
02	TLCHP-003-02P
:	:
24	TLCHP-003-24P

TLCPM-201

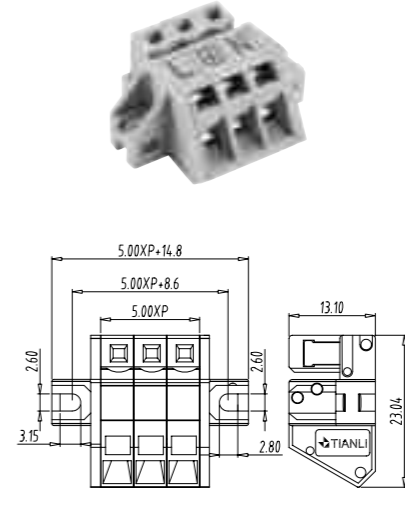

技术数据 Technical data	
Pitch (间距):	5.00mm
Approval (认证):	UL(Applying)
Rated voltage (电压):	300V
Rated current (电流):	16A
Wire range (线径):	22-12AWG
料号 Part Number	
极数 (Poles)	型号 (Model)
02	TLCPM-201-02P
:	:
24	TLCPM-201-24P

TLCHM-202

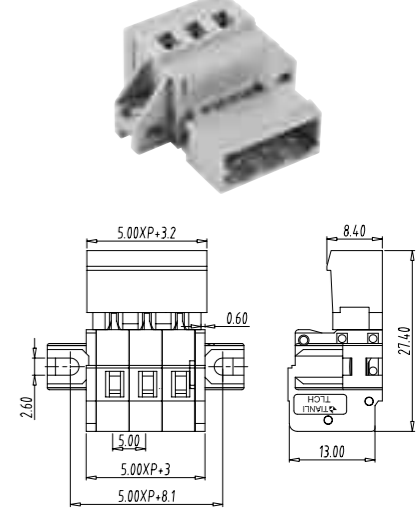

技术数据 Technical data	
Pitch (间距):	5.00mm
Approval (认证):	UL(Applying)
Rated voltage (电压):	300V
Rated current (电流):	16A
Wire range (线径):	22-12AWG
料号 Part Number	
极数 (Poles)	型号 (Model)
02	TLCHM-202-02P
:	:
24	TLCHM-202-24P

TLCP-203

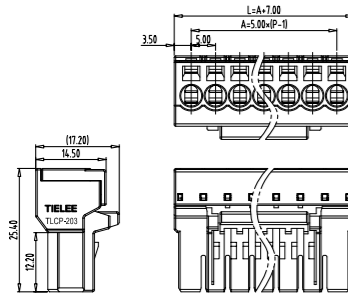

技术数据 Technical data	
Pitch (间距):	5.00mm
Approval (认证):	UL VDE(Applying)
Rated voltage (电压):	300V 320V
Rated current (电流):	14.5A 16A
Wire range (线径):	28-14AWG 0.2-2.5mm ²
料号 Part Number	
极数 (Poles)	型号 (Model)
02	TLCP-203-02P
:	:
14	TLCP-203-14P

TLCH-203

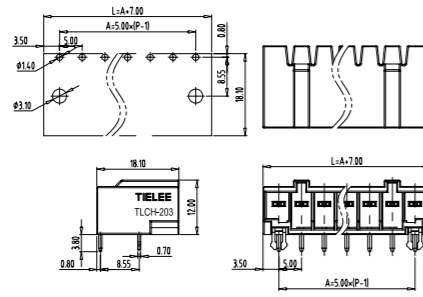

技术数据 Technical data	
Pitch (间距):	5.00mm
Approval (认证):	UL VDE(Applying)
Rated voltage (电压):	300V 320V
Rated current (电流):	14.5A 16A
PCB hole Dia(PCB 直径):	Φ 1.4mm/Φ 3.1mm
料号 Part Number	
极数 (Poles)	型号 (Model)
02	TLCH-203-02P
:	:
14	TLCH-203-14P

TLCP-403

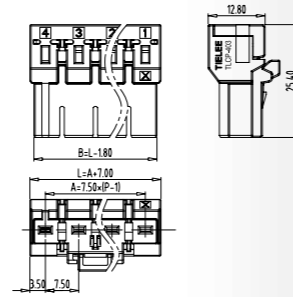

技术数据 Technical data	
Pitch (间距):	7.50mm
Approval (认证):	UL VDE(Applying)
Rated voltage (电压):	300V 630V
Rated current (电流):	16A 16A
Wire range (线径):	28-14AWG 0.2-2.5mm ²
料号 Part Number	
极数 (Poles)	型号 (Model)
03	TLCP-403-03P
:	:
12	TLCP-403-12P

TLCP-403L

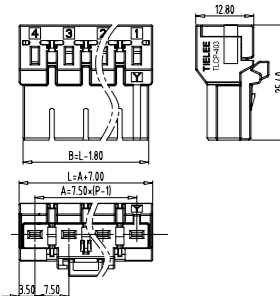

技术数据 Technical data	
Pitch (间距):	7.50mm
Approval (认证):	UL VDE(Applying)
Rated voltage (电压):	300V 630V
Rated current (电流):	16A 16A
Wire range (线径):	28-14AWG 0.2-2.5mm ²
料号 Part Number	
极数 (Poles)	型号 (Model)
03	TLCP-403L-03P
:	:
06	TLCP-403L-06P

TLCH-403

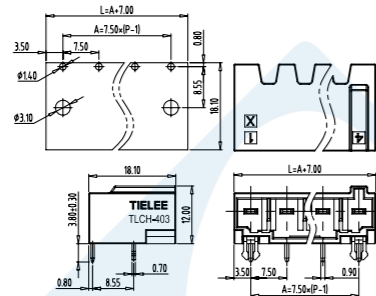

技术数据 Technical data	
Pitch (间距):	7.50mm
Approval (认证):	UL VDE(Applying)
Rated voltage (电压):	300V 630V
Rated current (电流):	16A 16A
PCB hole Dia(PCB 直径):	Φ 1.4mm/Φ 3.1mm
料号 Part Number	
极数 (Poles)	型号 (Model)
03	TLCH-403-03P
:	:
12	TLCH-403-12P

TLCH-403L

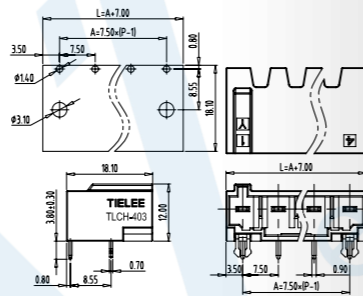

技术数据 Technical data	
Pitch (间距):	7.50mm
Approval (认证):	UL VDE(Applying)
Rated voltage (电压):	300V 630V
Rated current (电流):	16A 16A
PCB hole Dia(PCB 直径):	Φ 1.4mm/Φ 3.1mm
料号 Part Number	
极数 (Poles)	型号 (Model)
04	TLCH-403-04P
:	:
06	TLCH-403-06P

EB-5.0-01

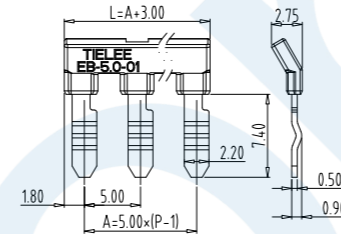

技术数据 Technical data	
Material (材质):	Copper Alloy PA66 UL94V-0
料号 Part Number	
极数 (Poles)	型号 (Model)
02	EB-5.0-01-02P
:	:
10	EB-5.0-01-10P

EB-5.0-02

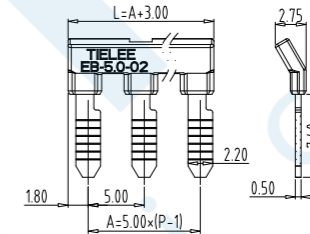

技术数据 Technical data	
Material (材质):	Copper Alloy PA66 UL94V-0
料号 Part Number	
极数 (Poles)	型号 (Model)
02	EB-5.0-02-02P
:	:
10	EB-5.0-02-10P

TLC-A01

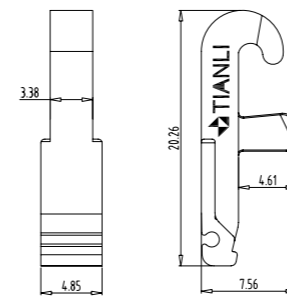

技术数据 Technical data	
Material (材质):	PA66
Part Number (料号):	TLC-A01
适用产品 Apply product	
TLCP/L/MW-200 / 300 / 400 / 500	
TLCP/L/MW-200A / 400A	
TLCP/L/MW-200F / 300F / 400F / 500F	
TLCP/L/MW-200FA / 400FA	

TLC-A02

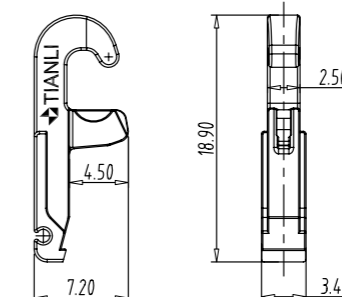

技术数据 Technical data	
Material (材质):	PA66
Part Number (料号):	TLC-A02
适用产品 Apply product	
TLCP-001	
TLCP-100	

TLC-A03

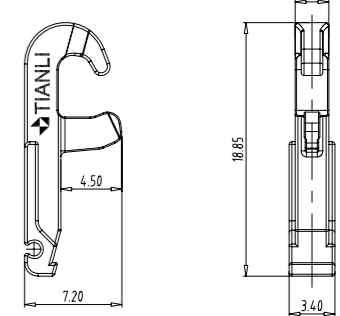

技术数据 Technical data	
Material (材质):	PA66
Part Number (料号):	TLC-A03
适用产品 Apply product	
TLCP-002	
TLCP-003	

TL SERIES – Wire Protector PCB Screw Terminal Block



How to order

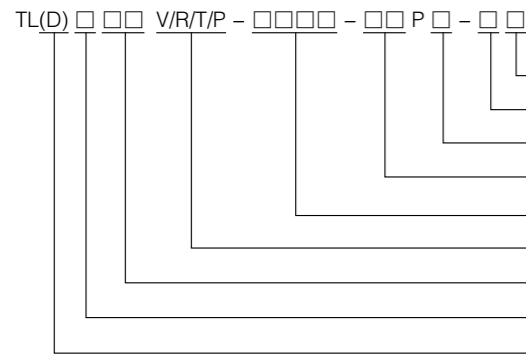

- Screw: S=Slot screw, C=Cross screw
- Color: K=Black, G(G12)=Green, L=Blue, B=Beige...
- 5=Double pitch, None=Standard pitch
- Poles
- Special code
- V=90°, R=180°, T=Header, P=Pin strip
- Series number
- Pitch: 0=3.50, 1=3.81, 2=5.00, 3=5.08, 4=7.50, 5=7.62, 6=9.52, 7=10.00, 8=10.16, 9=6.35
- D=Double row series

TL001V(TL100V)

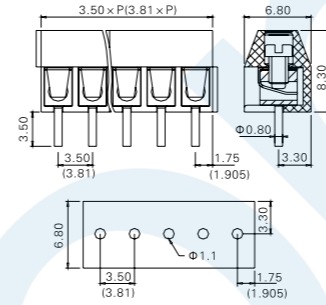
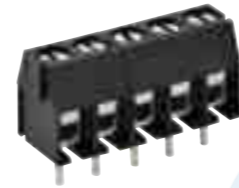

技术数据 Technical data	
Pitch (间距):	3.50mm(3.81mm)
Approval (认证):	UL
Rated voltage (电压):	300V
Rated current (电流):	10A
Wire range (线径):	24-16AWG
PCB hole Dia(PCB直径):	Φ 1.1mm
Screw (螺丝):	M2
料号 Part Number	
极数 (Poles)	型号 (Model)
02	TL001V-02P(TL100V-02P)
:	:
24	TL001V-24P(TL100V-24P)

TL001R(TL100R)

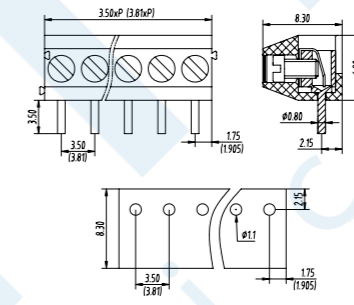

技术数据 Technical data	
Pitch (间距):	3.50mm(3.81mm)
Approval (认证):	UL
Rated voltage (电压):	300V
Rated current (电流):	10A
Wire range (线径):	24-16AWG
PCB hole Dia(PCB直径):	Φ 1.1mm
Screw (螺丝):	M2
料号 Part Number	
极数 (Poles)	型号 (Model)
02	TL001R-02P(TL100R-02P)
:	:
24	TL001R-24P(TL100R-24P)

TL012V

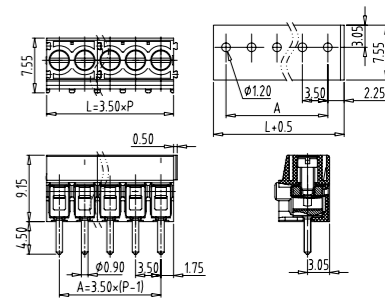
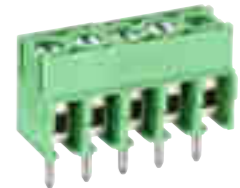

技术数据 Technical data	
Pitch (间距):	3.50mm
Approval (认证):	UL
Rated voltage (电压):	300V 160V
Rated current (电流):	10A 17.5A
Wire range (线径):	26-16AWG 0.2-1.5mm ²
Screw (螺丝):	M2
料号 Part Number	
极数 (Poles)	型号 (Model)
02	TL012V-02P
:	:
24	TL012V-48P

TL012R

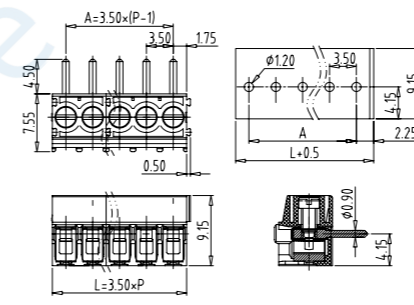
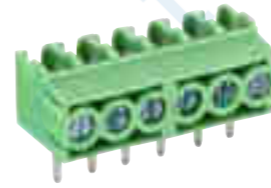

技术数据 Technical data	
Pitch (间距):	3.50mm
Approval (认证):	UL
Rated voltage (电压):	300V 160V
Rated current (电流):	10A 17.5A
Wire range (线径):	26-16AWG 0.2-1.5mm ²
Screw (螺丝):	M2
料号 Part Number	
极数 (Poles)	型号 (Model)
02	TL012R-02P
:	:
48	TL012R-48P

TL012A

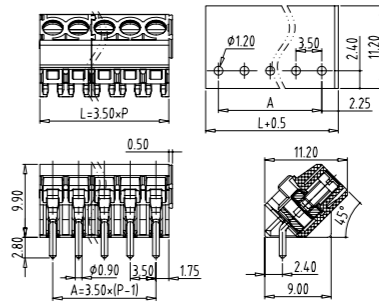
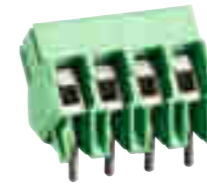

技术数据 Technical data	
Pitch (间距):	3.50mm
Approval (认证):	UL
Rated voltage (电压):	300V 160V
Rated current (电流):	10A 17.5A
Wire range (线径):	26-16AWG 0.2-1.5mm ²
Screw (螺丝):	M2
料号 Part Number	
极数 (Poles)	型号 (Model)
02	TL012A-02P
:	:
48	TL012A-48P

TL012A0

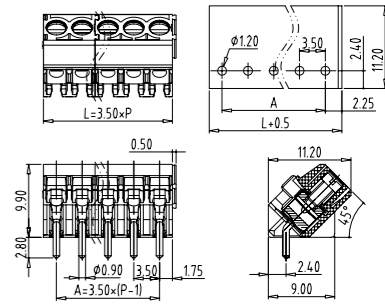
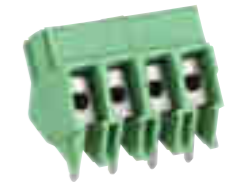

技术数据 Technical data	
Pitch (间距):	3.50mm
Approval (认证):	UL
Rated voltage (电压):	300V 160V
Rated current (电流):	10A 13.5A
Wire range (线径):	22-16AWG(str / sol) 16AWG(sol) 0.34-1mm ²
Screw (螺丝):	M2
料号 Part Number	
极数 (Poles)	型号 (Model)
02	TL012A0-02P
:	:
48	TL012A0-48P

TL200V(TL300V)

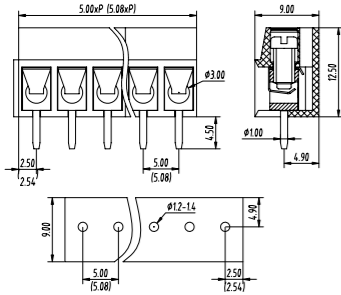
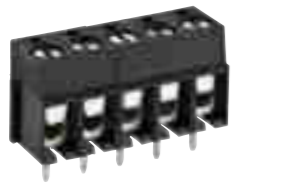

技术数据 Technical data	
Pitch (间距):	5.00mm(5.08mm)
Approval (认证):	
Rated voltage (电压):	300V 250V
Rated current (电流):	15A 24A
Wire range (线径):	22-14AWG 0.5-2.5mm ²
PCB hole Dia(PCB 直径):	Φ1.2-1.4mm
Screw (螺丝):	M3
料号 Part Number	
极数 (Poles)	型号 (Model)
02	TL200V-02P(TL300V-02P)
:	:
24	TL200V-24P(TL300V-24P)

TL200R(TL300R)

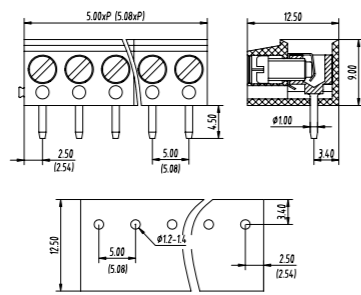
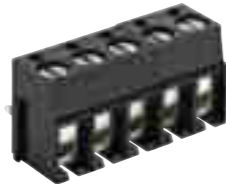

技术数据 Technical data	
Pitch (间距):	5.00mm(5.08mm)
Approval (认证):	
Rated voltage (电压):	300V 250V
Rated current (电流):	15A 24A
Wire range (线径):	22-14AWG 0.5-2.5mm ²
PCB hole Dia(PCB 直径):	Φ1.2-1.4mm
Screw (螺丝):	M3
料号 Part Number	
极数 (Poles)	型号 (Model)
02	TL200R-02P(TL300R-02P)
:	:
24	TL200R-24P(TL300R-24P)

TL201V(TL301V)

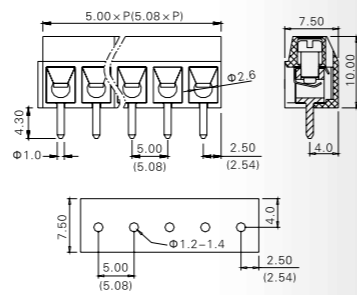

技术数据 Technical data	
Pitch (间距):	5.00mm(5.08mm)
Approval (认证):	
Rated voltage (电压):	300V 250V
Rated current (电流):	16A 16A
Wire range (线径):	20-14AWG 0.34-1.5mm ² 2.5mm ² iso1
PCB hole Dia(PCB 直径):	Φ1.2-1.4mm
Screw (螺丝):	M2.5
料号 Part Number	
极数 (Poles)	型号 (Model)
02	TL201V-02P(TL301V-02P)
:	:
24	TL201V-24P(TL301V-24P)

TL236R

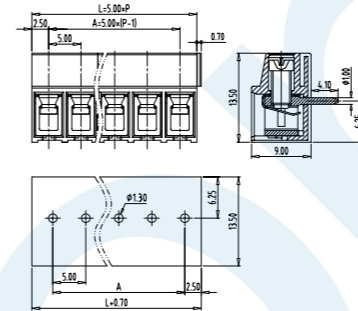
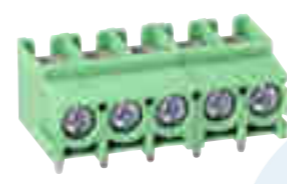

技术数据 Technical data	
Pitch (间距):	5.00mm
Approval (认证):	
Rated voltage (电压):	300V 320V
Rated current (电流):	20A 32A
Wire range (线径):	20-12AWG 0.5-4mm ²
PCB hole Dia(PCB 直径):	Φ1.30mm
Screw (螺丝):	M3
料号 Part Number	
极数 (Poles)	型号 (Model)
02	TL236R-02P
:	:
24	TL236R-24P

TL203V

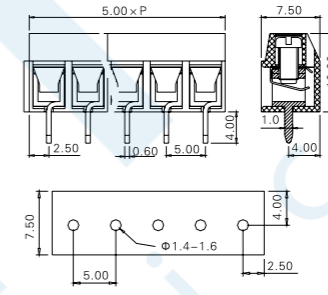

技术数据 Technical data	
Pitch (间距):	5.00mm
Approval (认证):	
Rated voltage (电压):	300V 250V
Rated current (电流):	16A 16A
Wire range (线径):	26-12AWG 0.2-2.5mm ²
PCB hole Dia(PCB 直径):	Φ1.4-1.6mm
Screw (螺丝):	M2.5
料号 Part Number	
极数 (Poles)	型号 (Model)
02	TL203V-02P
:	:
24	TL203V-24P

TL226V

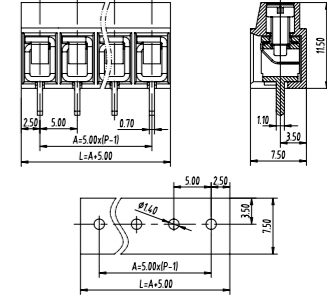
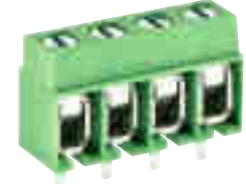

技术数据 Technical data	
Pitch (间距):	5.00mm
Approval (认证):	
Rated voltage (电压):	300V 320V
Rated current (电流):	16A 24A
Wire range (线径):	30-12AWG 0.2-2.5mm ²
PCB hole Dia(PCB 直径):	Φ1.4mm
Screw (螺丝):	M2.5
料号 Part Number	
极数 (Poles)	型号 (Model)
02	TL226V-02P
:	:
24	TL226V-24P

TL201R(TL301R)

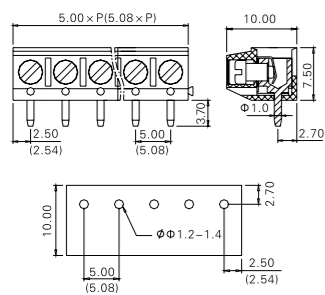

技术数据 Technical data	
Pitch (间距):	5.00mm(5.08mm)
Approval (认证):	
Rated voltage (电压):	300V 130V
Rated current (电流):	16A 16A
Wire range (线径):	20-14AWG 0.34-1.5mm ² 2.5mm ² iso1
PCB hole Dia(PCB 直径):	Φ1.2-1.4mm
Screw (螺丝):	M2.5
料号 Part Number	
极数 (Poles)	型号 (Model)
02	TL201R-02P(TL301R-02P)
:	:
24	TL201R-24P(TL301R-24P)

TL202V

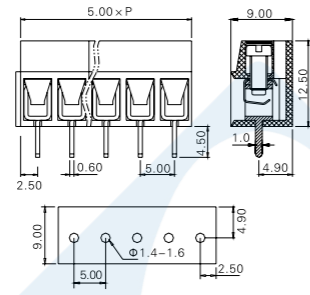
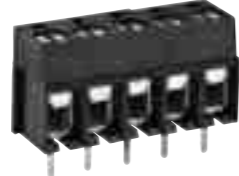

技术数据 Technical data	
Pitch (间距):	5.00mm
Approval (认证):	
Rated voltage (电压):	300V 320V
Rated current (电流):	16A 32A
Wire range (线径):	22-12AWG 1.5-4mm ²
PCB hole Dia(PCB 直径):	Φ1.4-1.6mm
Screw (螺丝):	M2.5
料号 Part Number	
极数 (Poles)	型号 (Model)
02	TL202V-02P
:	:
24	TL202V-24P

TL236V

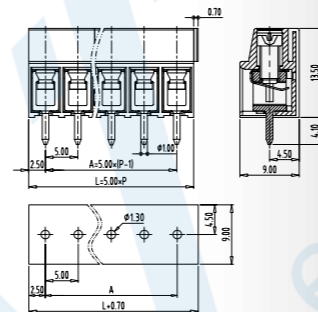
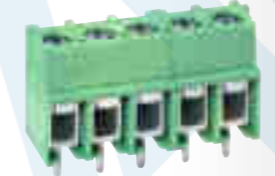

技术数据 Technical data	
Pitch (间距):	5.00mm
Approval (认证):	
Rated voltage (电压):	250V 320V
Rated current (电流):	20A 32A
Wire range (线径):	20-12AWG 0.5-4mm ²
PCB hole Dia(PCB 直径):	Φ1.30mm
Screw (螺丝):	M3
料号 Part Number	
极数 (Poles)	型号 (Model)
02	TL236V-02P
:	:
24	TL236V-24P

TL209V

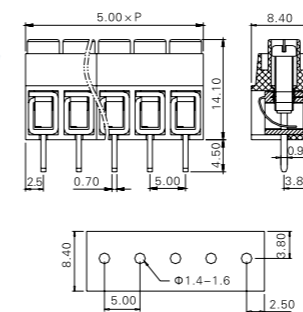

技术数据 Technical data	
Pitch (间距):	5.00mm
Approval (认证):	
Rated voltage (电压):	250V 320V
Rated current (电流):	15A 24A
Wire range (线径):	22-12AWG 0.2-2.5mm ²
PCB hole Dia(PCB 直径):	Φ1.4-1.6mm
Screw (螺丝):	M2.5
料号 Part Number	
极数 (Poles)	型号 (Model)
02	TL209V-02P
:	:
24	TL209V-24P

TL209R

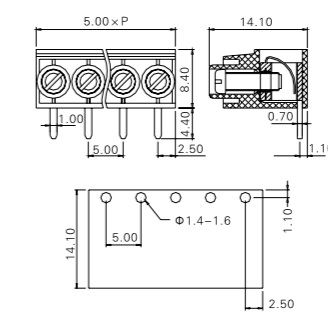

技术数据 Technical data	
Pitch (间距):	5.00mm
Approval (认证):	
Rated voltage (电压):	250V 320V
Rated current (电流):	15A 24A
Wire range (线径):	22-12AWG 0.2-2.5mm ²
PCB hole Dia(PCB 直径):	Φ1.4-1.6mm
Screw (螺丝):	M2.5
料号 Part Number	
极数 (Poles)	型号 (Model)
02	TL209R-02P
:	:
24	TL209R-24P

TL210

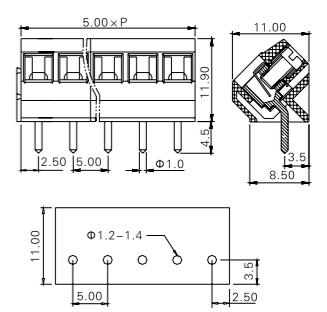

技术数据 Technical data	
Pitch (间距):	5.00mm
Approval (认证):	
Rated voltage (电压):	300V
Rated current (电流):	15A
Wire range (线径):	22-14AWG
CB hole Dia(PCB 直径):	Φ1.2-1.4mm
Screw (螺丝):	M2.5
料号 Part Number	
极数 (Poles)	型号 (Model)
02	TL210-02P
:	:
24	TL210-24P

TL213-5.0

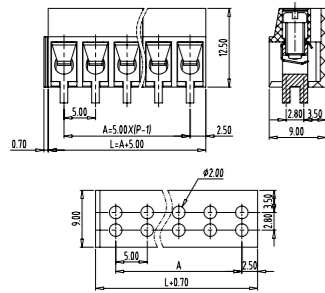
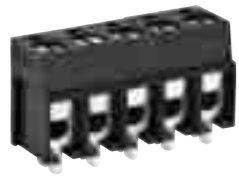

技术数据 Technical data	
Pitch (间距):	5.00mm
Approval (认证):	UL VDE(Applying)
Rated voltage (电压):	300V 320V
Rated current (电流):	20A 24A
Wire range (线径):	24-14AWG 0.5-2.5mm ²
PCB hole Dia(PCB直径):	Φ1.9-2.2mm
Screw (螺丝):	M3
料号 Part Number	
极数 (Poles)	型号 (Model)
02	TL213-5.0-02P
:	:
24	TL213-5.0-24P

TL216

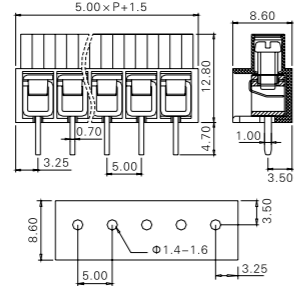
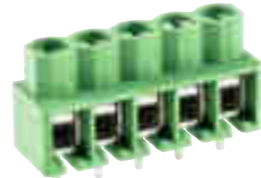

技术数据 Technical data	
Pitch (间距):	5.00mm
Approval (认证):	UL VDE
Rated voltage (电压):	300V 450V
Rated current (电流):	12A 12A
Wire range (线径):	18-12AWG 0.75-4mm ²
PCB hole Dia(PCB直径):	Φ1.4-1.6mm
Screw (螺丝):	M3
料号 Part Number	
极数 (Poles)	型号 (Model)
02	TL216-02P
:	:
24	TL216-24P

TL400V

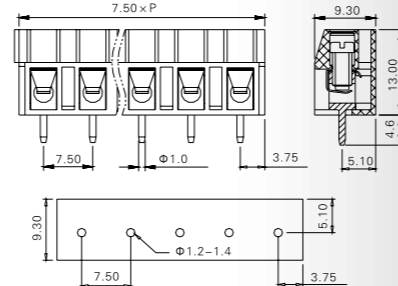

技术数据 Technical data	
Pitch (间距):	7.50mm
Approval (认证):	UL VDE
Rated voltage (电压):	300V 450V
Rated current (电流):	16A 24A
Wire range (线径):	22-14AWG 0.5-2.5mm ²
PCB hole Dia(PCB直径):	Φ1.2-1.4mm
Screw (螺丝):	M3
料号 Part Number	
极数 (Poles)	型号 (Model)
02	TL400V-02P
:	:
24	TL400V-24P

TL006T

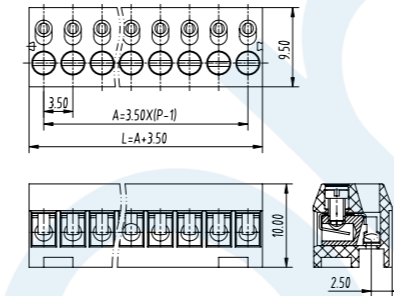

技术数据 Technical data	
Pitch (间距):	3.50mm
Approval (认证):	UL VDE
Rated voltage (电压):	300V
Rated current (电流):	10A
Wire range (线径):	28-16AWG
Screw (螺丝):	M2.0
料号 Part Number	
极数 (Poles)	型号 (Model)
02	TL006T-02P
:	:
24	TL006T-24P

TL008T-HA

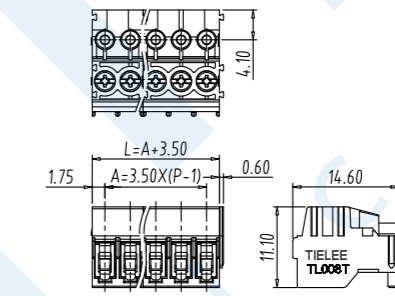

技术数据 Technical data	
Pitch (间距):	3.50mm
Approval (认证):	UL VDE
Rated voltage (电压):	300V 320V
Rated current (电流):	12A 12A
Wire range (线径):	26-16WG 0.2-1.5mm ²
料号 Part Number	
极数 (Poles)	型号 (Model)
02	TL008T-HA-02P
:	:
24	TL008T-HA-24P

TL039

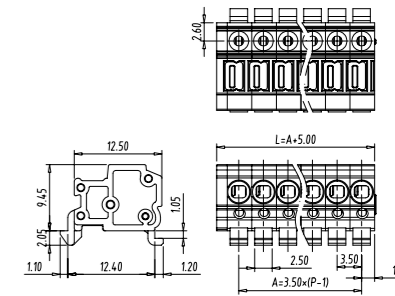
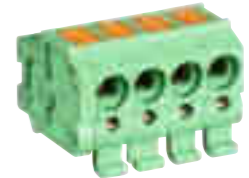

技术数据 Technical data	
Pitch (间距):	3.50mm
Approval (认证):	UL VDE(Applying)
Rated voltage (电压):	150V 160V
Rated current (电流):	7A 10A
Wire range (线径):	28-16WG 0.5-1.5mm ²
料号 Part Number	
极数 (Poles)	型号 (Model)
02	TL039-02P
:	:
24	TL039-24P

TL400R

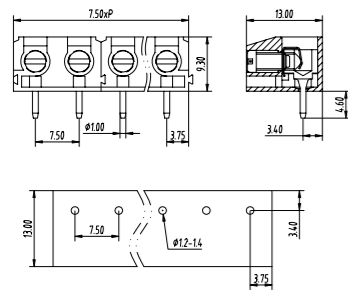

技术数据 Technical data	
Pitch (间距):	7.50mm
Approval (认证):	UL VDE
Rated voltage (电压):	300V 450V
Rated current (电流):	16A 24A
Wire range (线径):	22-14AWG 0.5-2.5mm ²
PCB hole Dia(PCB直径):	Φ1.2-1.4mm
Screw (螺丝):	M3
料号 Part Number	
极数 (Poles)	型号 (Model)
02	TL400R-02P
:	:
24	TL400R-24P

TL523

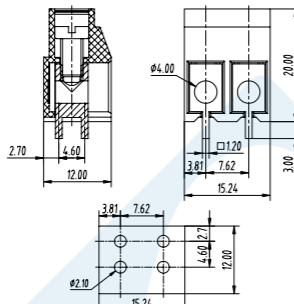

技术数据 Technical data	
Pitch (间距):	7.62mm
Approval (认证):	UL VDE
Rated voltage (电压):	300V 750V
Rated current (电流):	35A 41A
Wire range (线径):	30-8AWG 1-6mm ²
PCB hole Dia(PCB直径):	Φ2.1mm
Screw (螺丝):	M4.0
料号 Part Number	
极数 (Poles)	型号 (Model)
02	TL523-02P

TL509V

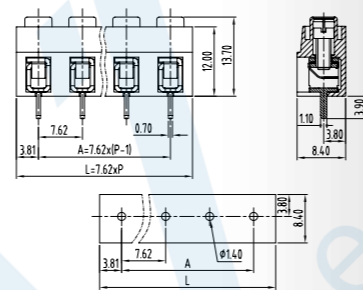

技术数据 Technical data	
Pitch (间距):	7.62mm
Approval (认证):	UL VDE(Applying)
Rated voltage (电压):	300V 630V
Rated current (电流):	16A 24A
Wire range (线径):	30-12AWG 0.5-2.5mm ²
PCB hole Dia(PCB直径):	Φ1.4mm
Screw (螺丝):	M2.5
料号 Part Number	
极数 (Poles)	型号 (Model)
02	TL509V-02P
:	:
16	TL509V-16P

TL039T

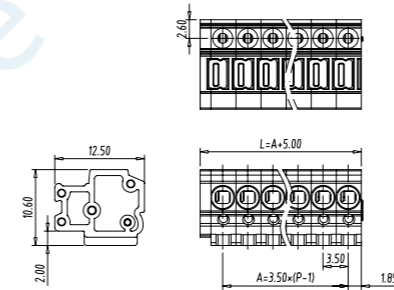

技术数据 Technical data	
Pitch (间距):	3.50mm
Approval (认证):	UL VDE(Applying)
Rated voltage (电压):	150V 160V
Rated current (电流):	7A 10A
Wire range (线径):	28-16WG 0.5-1.5mm ²
料号 Part Number	
极数 (Poles)	型号 (Model)
02	TL039T-02P
:	:
24	TL039T-24P

TL205T

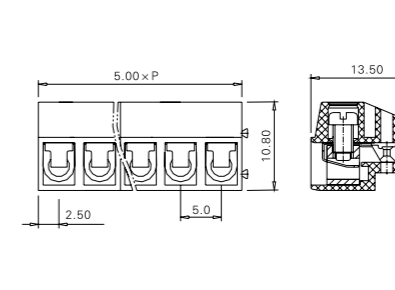

技术数据 Technical data	
Pitch (间距):	5.00mm
Approval (认证):	UL VDE
Rated voltage (电压):	300V 630V
Rated current (电流):	10A 11A
Wire range (线径):	20-14AWG 0.2-1.5mm ² 2.5mm ² sci
Screw (螺丝):	M2.5
料号 Part Number	
极数 (Poles)	型号 (Model)
02	TL205T-02P
:	:
24	TL205T-24P

TL221T

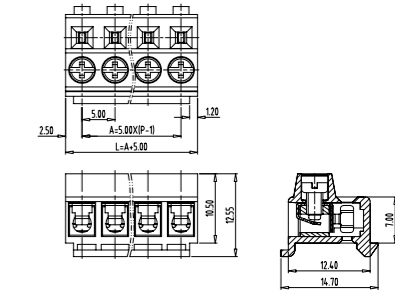

技术数据 Technical data	
Pitch (间距):	5.00mm
Approval (认证):	UL VDE
Rated voltage (电压):	300V 320V
Rated current (电流):	10A 12A
Wire range (线径):	20-14AWG 0.34-2.5mm ²
Screw (螺丝):	M2.5
料号 Part Number	
极数 (Poles)	型号 (Model)
02	TL221T-02P
:	:
24	TL221T-24P

TL222T

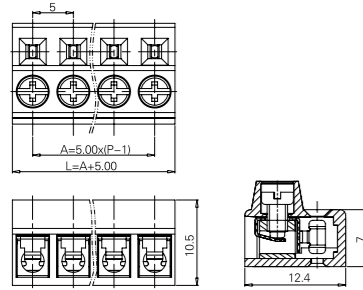

技术数据 Technical data	
Pitch (间距):	5.0mm
Approval (认证):	UL VDE(Applying)
Rated voltage (电压):	300V 320V
Rated current (电流):	10A 12A
Wire range (线径):	24–14AWG 0.34–2.5mm ²
Screw (螺丝):	M2.5

料号 Part Number	
极数 (Poles)	型号 (Model)
02	TL222T-02P
:	:
24	TL222T-24P

TL223T

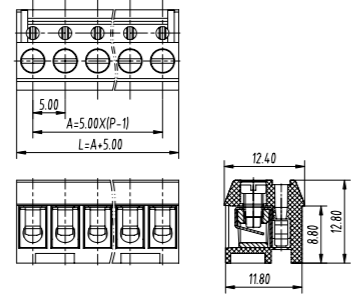

技术数据 Technical data	
Pitch (间距):	5.0mm
Approval (认证):	UL VDE(Applying)
Rated voltage (电压):	300V 320V
Rated current (电流):	12A 12A
Wire range (线径):	26–12AWG
Screw (螺丝):	M3.0

料号 Part Number	
极数 (Poles)	型号 (Model)
02	TL223T-02P
:	:
24	TL223T-24P

TL235T-HA

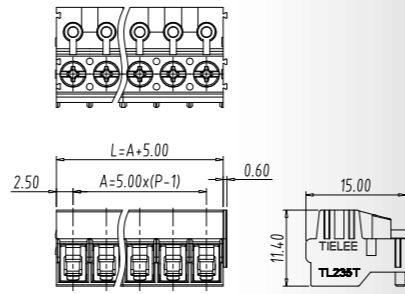

技术数据 Technical data	
Pitch (间距):	5.0mm
Approval (认证):	UL VDE(Applying)
Rated voltage (电压):	300V 630V
Rated current (电流):	15A 19A
Wire range (线径):	26–14AWG 12AWG Sol 0.2–2.5mm ²
Screw (螺丝):	M2.5

料号 Part Number	
极数 (Poles)	型号 (Model)
02	TL235T-02P-HA
:	:
24	TL235T-24P-HA

TL239T

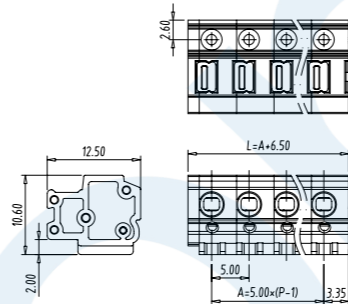
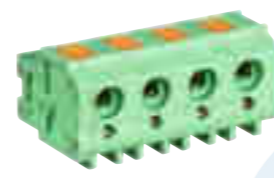

技术数据 Technical data	
Pitch (间距):	5.0mm
Approval (认证):	UL VDE(Applying)
Rated voltage (电压):	300V 320V
Rated current (电流):	7A 10A
Wire range (线径):	28–16WG 0.5–1.5mm ²

料号 Part Number	
极数 (Poles)	型号 (Model)
02	TL239T-02P
:	:
24	TL239T-24P

TL006P

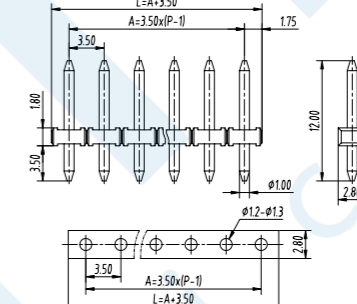
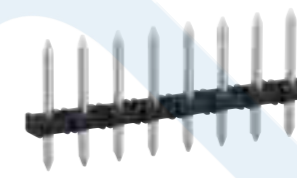

技术数据 Technical data	
Pitch (间距):	3.50mm
Approval (认证):	UL VDE(Applying)
Rated voltage (电压):	300V 250V
Rated current (电流):	10A 12A
PCB hole Dia(PCB直径):	Φ 1.2–1.3mm

料号 Part Number	
极数 (Poles)	型号 (Model)
02	TL006P-02P
:	:
24	TL006P-24P

TL007P

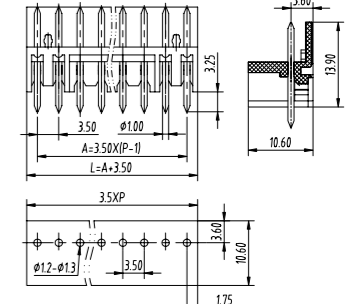

技术数据 Technical data	
Pitch (间距):	3.50mm
Approval (认证):	UL VDE(Applying)
Rated voltage (电压):	300V
Rated current (电流):	10A
PCB hole Dia(PCB直径):	Φ 1.2–1.3mm

料号 Part Number	
极数 (Poles)	型号 (Model)
02	TL007P-02P
:	:
24	TL007P-24P

TL219

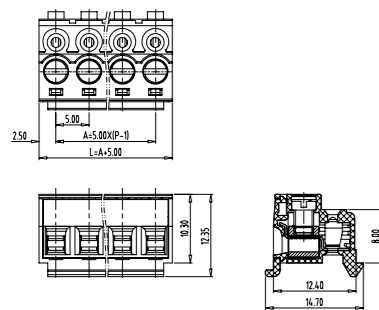

技术数据 Technical data	
Pitch (间距):	5.0mm
Approval (认证):	UL VDE(Applying)
Rated voltage (电压):	300V 630V
Rated current (电流):	12A 12A
Wire range (线径):	28–14AWG 0.2–1.5mm ² 2.5 sol
Screw (螺丝):	M2.5

料号 Part Number	
极数 (Poles)	型号 (Model)
02	TL219-02P
:	:
24	TL219-24P

TL219T

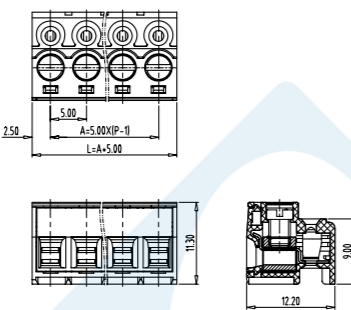

技术数据 Technical data	
Pitch (间距):	5.0mm
Approval (认证):	UL VDE(Applying)
Rated voltage (电压):	300V 630V
Rated current (电流):	12A 12A
Wire range (线径):	28–14AWG 0.2–1.5mm ² 2.5 sol
Screw (螺丝):	M2.5

料号 Part Number	
极数 (Poles)	型号 (Model)
02	TL219T-02P
:	:
24	TL219T-24P

TL239

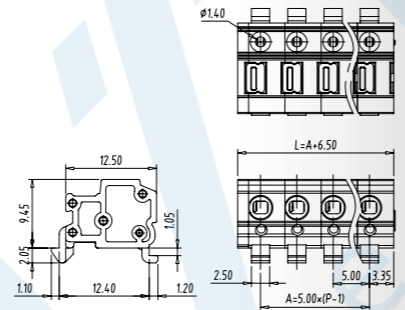

技术数据 Technical data	
Pitch (间距):	5.0mm
Approval (认证):	UL VDE(Applying)
Rated voltage (电压):	300V 320V
Rated current (电流):	7A 10A
Wire range (线径):	28–16WG 0.5–1.5mm ²

料号 Part Number	
极数 (Poles)	型号 (Model)
02	TL239-02P
:	:
24	TL239-24P

TL205P

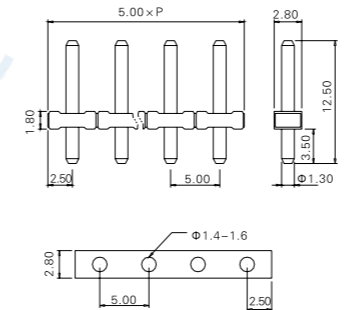

技术数据 Technical data	
Pitch (间距):	5.00mm
Approval (认证):	UL VDE(Applying)
Rated voltage (电压):	300V 320V
Rated current (电流):	10A 19A
PCB hole Dia(PCB直径):	Φ 1.4–1.6mm

料号 Part Number	
极数 (Poles)	型号 (Model)
02	TL205P-02P
:	:
24	TL205P-24P

TL205P-A019

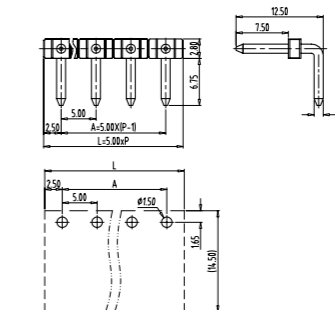

技术数据 Technical data	
Pitch (间距):	5.00mm
Approval (认证):	UL(Applying)
Rated voltage (电压):	300V
Rated current (电流):	10A
PCB hole Dia(PCB直径):	Φ 1.50mm

料号 Part Number	
极数 (Poles)	型号 (Model)
02	TL205P-A019-02P
:	:
24	TL205P-A019-24P

TL205P-1082

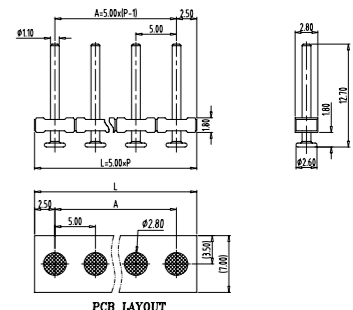

技术数据 Technical data	
Pitch (间距):	5.0mm
Approval (认证):	UL(Applying)
Rated voltage (电压):	300V
Rated current (电流):	10A

料号 Part Number	
极数 (Poles)	型号 (Model)
02	TL205P-1082-02P
:	:
24	TL205P-1082-24P

TL SERIES – Raising Clamp PCB Screw Terminal Block

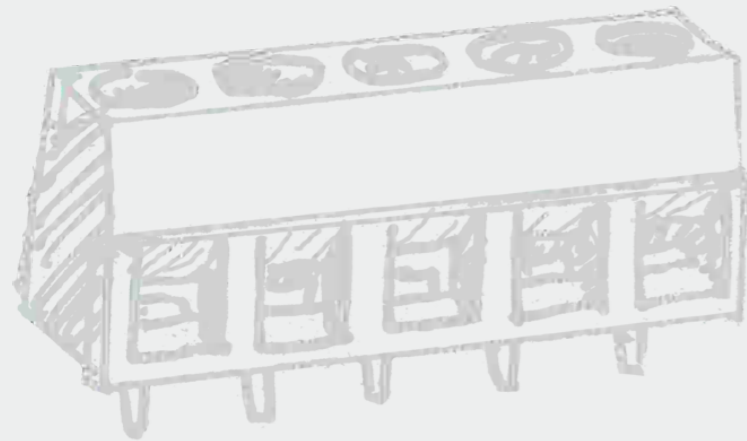

TL Single row series 单层

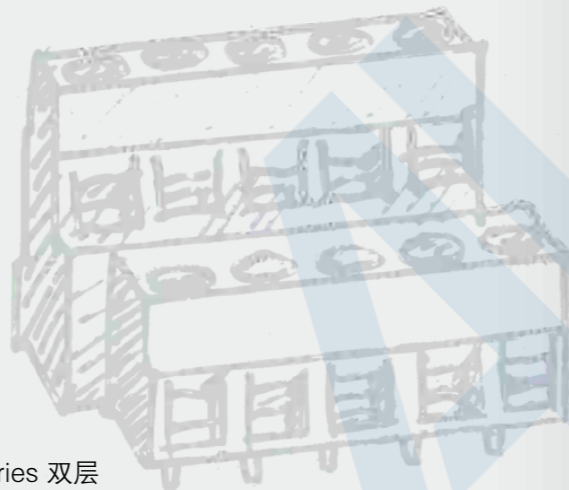

TLD Double row series 双层

How to order

TL(D) □ □ □ V/R/T/P - □ □ □ □ - □ □ P □ - □ □

- Screw: S=Slot screw, C=Cross screw
- Color: K=Black, G(G12)=Green, L=Blue, B=Beige...
- 5=Double pitch, None=Standard pitch
- Poles
- Special code
- V=90°, R=180°, T=Header, P=Pin strip
- Series number
- Pitch: 0=3.50, 1=3.81, 2=5.00, 3=5.08, 4=7.50, 5=7.62, 6=9.52, 7=10.00, 8=10.16, 9=6.35
- D=Double row series

TL011V

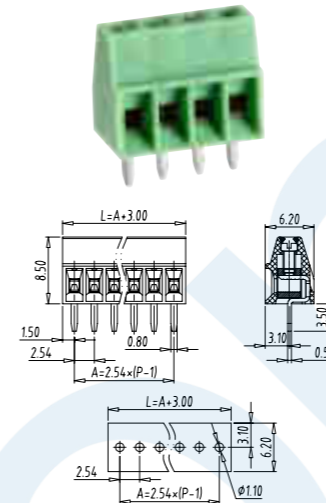

技术数据 Technical data	
Pitch (间距):	2.54mm
Approval (认证):	
Rated voltage (电压):	150V 160V
Rated current (电流):	6A 8A
Wire range (线径):	30-18AWG 0.2-1.0mm ²
PCB hole Dia(PCB直径):	Φ 1.1mm
Screw (螺丝):	M1.6
料号 Part Number	
极数 (Poles)	型号 (Model)
02	TL011V-02P
:	:
24	TL011V-24P

TL002V

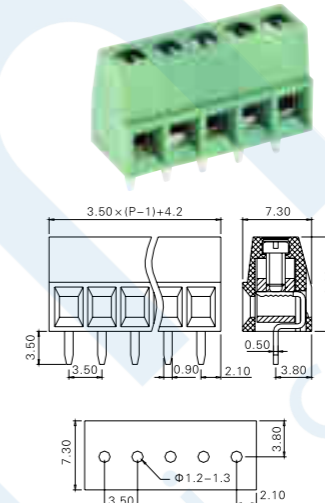

技术数据 Technical data	
Pitch (间距):	3.50mm
Approval (认证):	
Rated voltage (电压):	300V 130V
Rated current (电流):	10A 10A
Wire range (线径):	26-16AWG 0.2-1.5mm ²
PCB hole Dia(PCB直径):	Φ 1.2-1.3mm
Screw (螺丝):	M2
料号 Part Number	
极数 (Poles)	型号 (Model)
02	TL002V-02P
:	:
24	TL002V-24P

TL003V(TL103V)

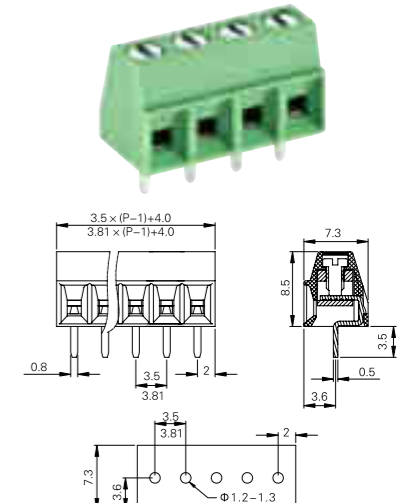

技术数据 Technical data	
Pitch (间距):	3.50mm(3.81mm)
Approval (认证):	
Rated voltage (电压):	300V 160V
Rated current (电流):	10A 16A
Wire range (线径):	26-16AWG 0.2-1.5mm ²
PCB hole Dia(PCB直径):	Φ 1.2-1.3mm
Screw (螺丝):	M2
料号 Part Number	
极数 (Poles)	型号 (Model)
02	TL003V-02P(TL103V-02P)
:	:
24	TL003V-24P(TL103V-24P)

TL004V(TL104V)

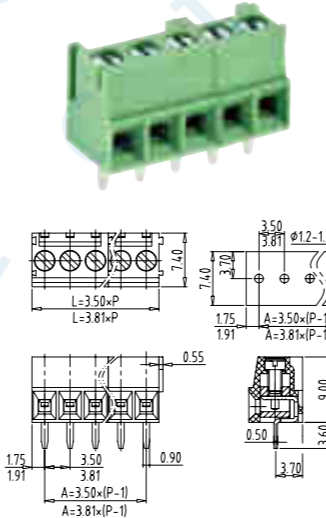

技术数据 Technical data	
Pitch (间距):	3.50mm(3.81mm)
Approval (认证):	
Rated voltage (电压):	300V
Rated current (电流):	10A
Wire range (线径):	26-16AWG
PCB hole Dia(PCB直径):	Φ 1.2-1.3mm
Screw (螺丝):	M2
料号 Part Number	
极数 (Poles)	型号 (Model)
02	TL004V-02P(TL104V-02P)
:	:
24	TL004V-24P(TL104V-24P)

TL004R(TL104R)

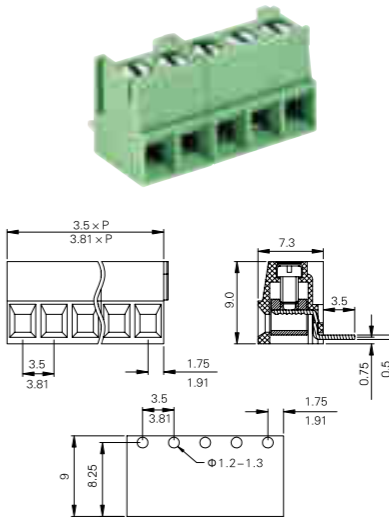

技术数据 Technical data	
Pitch (间距):	3.50mm(3.81mm)
Approval (认证):	
Rated voltage (电压):	300V
Rated current (电流):	10A
Wire range (线径):	26-16AWG
PCB hole Dia(PCB直径):	Φ 1.2-1.3mm
Screw (螺丝):	M2
料号 Part Number	
极数 (Poles)	型号 (Model)
02	TL004R-02P(TL104R-02P)
:	:
24	TL004R-24P(TL104R-24P)

TL009(TL109)

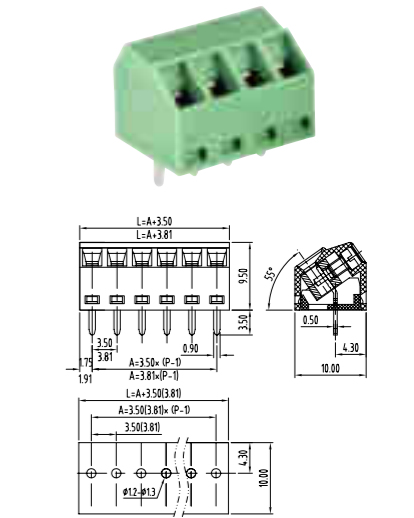

技术数据 Technical data	
Pitch (间距):	3.50mm(3.81mm)
Approval (认证):	
Rated voltage (电压):	300V
Rated current (电流):	12A
Wire range (线径):	30-16AWG
PCB hole Dia(PCB直径):	Φ 1.2-1.3mm
Screw (螺丝):	M2.0
料号 Part Number	
极数 (Poles)	型号 (Model)
02	TL009-02P (TL109-02P)
:	:
24	TL009-24P (TL109-24P)

TL010

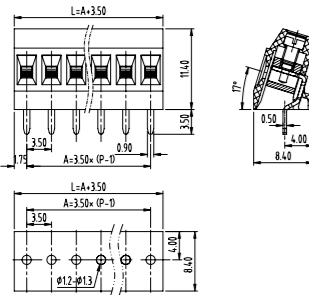
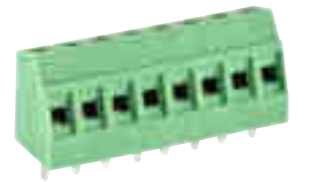

技术数据 Technical data	
Pitch (间距):	3.50mm
Approval (认证):	UL, CE, Ex, CQC
Rated voltage (电压):	300V
Rated current (电流):	10A
Wire range (线径):	26-16AWG
PCB hole Dia(PCB 直径):	Φ 1.2-1.3mm
Screw (螺丝):	M2.0
料号 Part Number	
极数 (Poles)	型号 (Model)
02	TL010-02P
:	:
24	TL010-24P

TL204

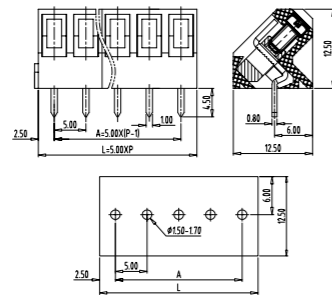
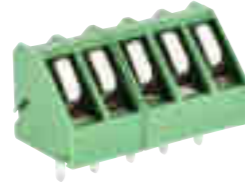

技术数据 Technical data	
Pitch (间距):	5.00mm
Approval (认证):	UL, CE, Ex, CQC
Rated voltage (电压):	250V 320V
Rated current (电流):	16A 24A
Wire range (线径):	26-12AWG 0.34-2.5mm ²
PCB hole Dia(PCB 直径):	Φ 1.5-1.7mm
Screw (螺丝):	M2.5
料号 Part Number	
极数 (Poles)	型号 (Model)
02	TL204-02P
:	:
24	TL204-24P

TL207(TL307)

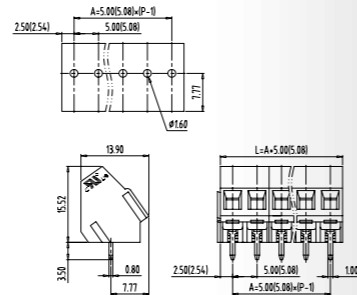

技术数据 Technical data	
Pitch (间距):	5.00mm(5.08mm)
Approval (认证):	UL, CE, Ex, CQC VDE(Applying)
Rated voltage (电压):	320V 300V
Rated current (电流):	24A 20A
Wire range (线径):	24-12AWG 0.2-2.5mm ²
PCB hole Dia(PCB 直径):	Φ 1.60mm
Screw (螺丝):	M3
料号 Part Number	
极数 (Poles)	型号 (Model)
02	TL207-02P(TL307-02P)
:	:
26	TL207-26P(TL307-26P)

TL214V

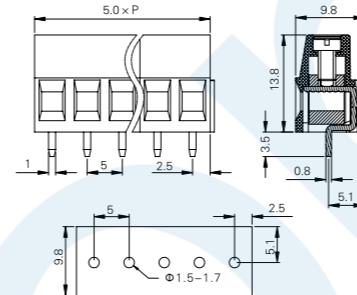

技术数据 Technical data	
Pitch (间距):	5.00mm
Approval (认证):	UL, CE, Ex, CQC
Rated voltage (电压):	300V
Rated current (电流):	20A
Wire range (线径):	24-12AWG
PCB hole Dia(PCB 直径):	Φ 1.5-1.7mm
Screw (螺丝):	M2.5
料号 Part Number	
极数 (Poles)	型号 (Model)
02	TL214V-02P
:	:
24	TL214V-24P

TL214R

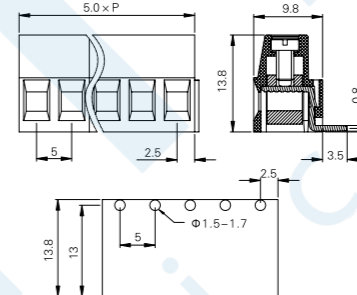
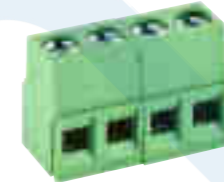

技术数据 Technical data	
Pitch (间距):	5.00mm
Approval (认证):	UL, CE, Ex, CQC
Rated voltage (电压):	300V
Rated current (电流):	20A
Wire range (线径):	24-12AWG
PCB hole Dia(PCB 直径):	Φ 1.5-1.7mm
Screw (螺丝):	M2.5
料号 Part Number	
极数 (Poles)	型号 (Model)
02	TL214R-02P
:	:
24	TL214R-24P

TL208V(TL308V)

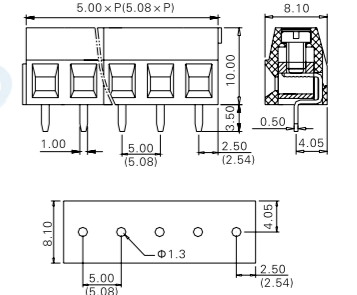
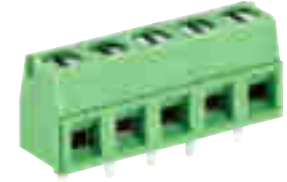

技术数据 Technical data	
Pitch (间距):	5.00mm(5.08mm)
Approval (认证):	UL, CE, Ex, CQC
Rated voltage (电压):	300V 320V
Rated current (电流):	15A 15A
Wire range (线径):	26-14AWG 0.34-1.5mm ²
PCB hole Dia(PCB 直径):	Φ 1.3mm
Screw (螺丝):	M3
料号 Part Number	
极数 (Poles)	型号 (Model)
02	TL208V-02P(TL308V-02P)
:	:
24	TL208V-24P(TL308V-24P)

TL231(TL331)

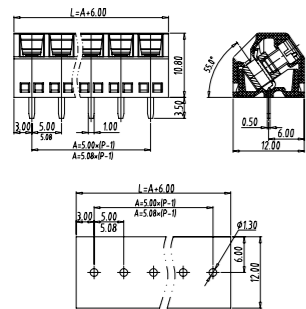
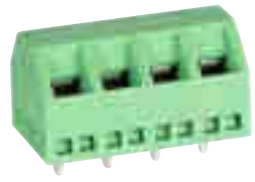

技术数据 Technical data	
Pitch (间距):	5.00mm(5.08mm)
Approval (认证):	UL, CE, Ex, CQC
Rated voltage (电压):	300V 320V
Rated current (电流):	13.5A 15A
Wire range (线径):	26-14AWG 0.2-1.5mm ²
Screw (螺丝):	M3
料号 Part Number	
极数 (Poles)	型号 (Model)
02	TL231-02P(TL331-02P)
:	:
24	TL231-02P(TL331-24P)

TL206V(TL306V)

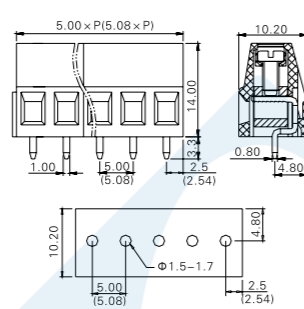

技术数据 Technical data	
Pitch (间距):	5.00mm(5.08mm)
Approval (认证):	UL, CE, Ex, CQC
Rated voltage (电压):	300V 320V
Rated current (电流):	20A 24A
Wire range (线径):	24-12AWG 0.2-2.5mm ² sol / str 4mm ² sol
PCB hole Dia(PCB 直径):	Φ 1.5-1.7mm
Screw (螺丝):	M3
料号 Part Number	
极数 (Poles)	型号 (Model)
02	TL206V-02P(TL306V-02P)
:	:
24	TL206V-24P(TL306V-24P)

TL206R(TL306R)

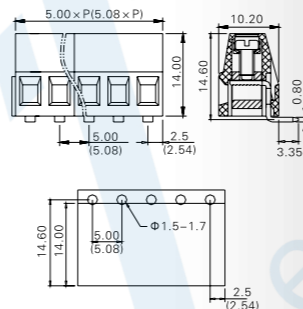
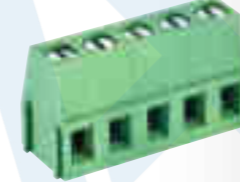

技术数据 Technical data	
Pitch (间距):	5.00mm(5.08mm)
Approval (认证):	UL, CE, Ex, CQC
Rated voltage (电压):	300V 320V
Rated current (电流):	20A 24A
Wire range (线径):	24-12AWG 0.2-2.5mm ² sol / str 4mm ² sol
PCB hole Dia(PCB 直径):	Φ 1.5-1.7mm
Screw (螺丝):	M3
料号 Part Number	
极数 (Poles)	型号 (Model)
02	TL206R-02P(TL306R-02P)
:	:
24	TL206R-24P(TL306R-24P)

TL215V

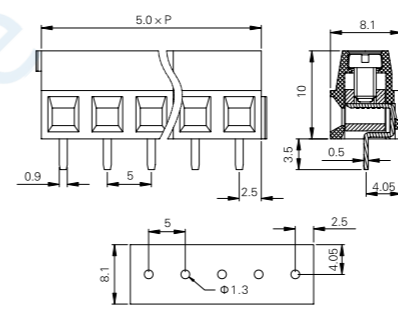

技术数据 Technical data	
Pitch (间距):	5.00mm
Approval (认证):	UL, CE, Ex, CQC
Rated voltage (电压):	300V
Rated current (电流):	15A
Wire range (线径):	26-14AWG
PCB hole Dia(PCB 直径):	Φ 1.3mm
Screw (螺丝):	M3
料号 Part Number	
极数 (Poles)	型号 (Model)
02	TL215V-02P
:	:
24	TL215V-24P

TL215R

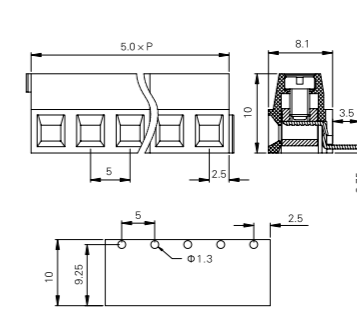

技术数据 Technical data	
Pitch (间距):	5.00mm
Approval (认证):	UL, CE, Ex, CQC
Rated voltage (电压):	300V
Rated current (电流):	15A
Wire range (线径):	26-14AWG
PCB hole Dia(PCB 直径):	Φ 1.3mm
Screw (螺丝):	M3
料号 Part Number	
极数 (Poles)	型号 (Model)
02	TL215R-02P
:	:
24	TL215R-24P

TL211V

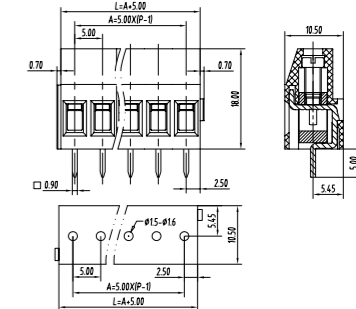

技术数据 Technical data	
Pitch (间距):	5.00mm
Approval (认证):	UL, CE, Ex, CQC
Rated voltage (电压):	300V 320V
Rated current (电流):	25A 32A
Wire range (线径):	22-12AWG 0.24-4mm ²
PCB hole Dia(PCB 直径):	Φ 1.5-1.6mm
Screw (螺丝):	M3
料号 Part Number	
极数 (Poles)	型号 (Model)
02	TL211V-02P
:	:
24	TL211V-24P

TL211VH

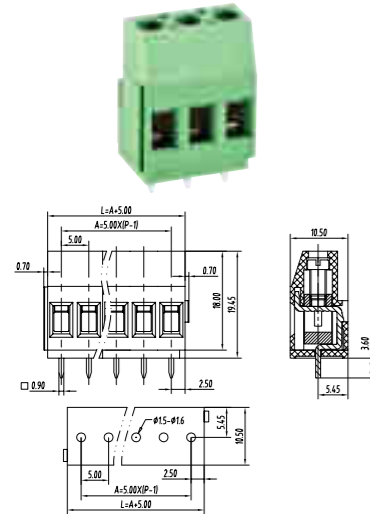

技术数据 Technical data	
Pitch (间距):	5.00mm
Approval (认证):	UL CE
Rated voltage (电压):	300V 320V
Rated current (电流):	25A 32A
Wire range (线径):	22-12AWG 0.24-4mm ²
PCB hole Dia(PCB直径):	Φ 1.5-1.6mm
Screw (螺丝):	M3
料号 Part Number	
极数 (Poles)	型号 (Model)
02	TL211VH-02P
:	:
24	TL211VH-24P

TL212V(TL312V)

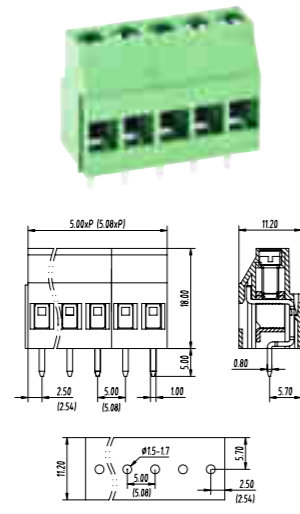

技术数据 Technical data	
Pitch (间距):	5.00mm(5.08mm)
Approval (认证):	UL CE
Rated voltage (电压):	300V 300V
Rated current (电流):	20A 20A
Wire range (线径):	24-12AWG 0.34-4mm ²
PCB hole Dia(PCB直径):	Φ 1.5-1.7mm
Screw (螺丝):	M2.5
料号 Part Number	
极数 (Poles)	型号 (Model)
02	TL212V-02P(TL312V-02P)
:	:
24	TL212V-24P(TL312V-24P)

TL217VA

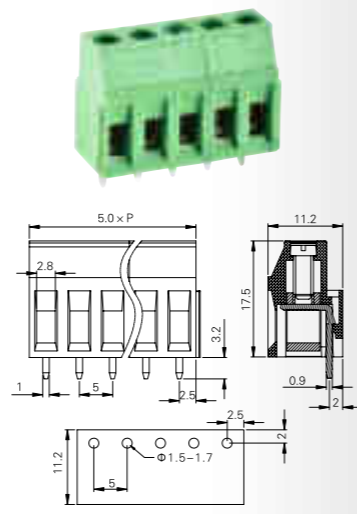

技术数据 Technical data	
Pitch (间距):	5.00mm
Approval (认证):	UL CE
Rated voltage (电压):	300V 320V
Rated current (电流):	20A 24A
Wire range (线径):	24-12AWG 0.34-2.5mm ²
PCB hole Dia(PCB直径):	Φ 1.5-1.7mm
Screw (螺丝):	M2.5
料号 Part Number	
极数 (Poles)	型号 (Model)
02	TL217VA-02P
:	:
24	TL217VA-24P

TL220VA

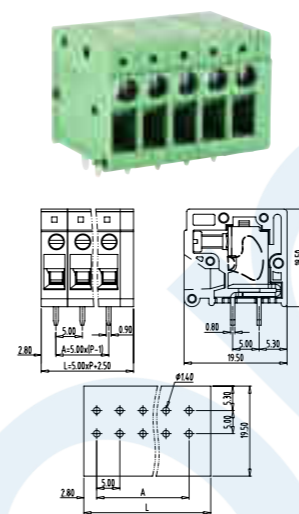

技术数据 Technical data	
Pitch (间距):	5.00mm
Approval (认证):	UL CE
Rated voltage (电压):	300V 320V
Rated current (电流):	20A 24A
Wire range (线径):	28-12AWG 0.34-2.5mm ²
PCB hole Dia(PCB直径):	Φ 1.40mm
Screw (螺丝):	M2.5
料号 Part Number	
极数 (Poles)	型号 (Model)
02	TL220VA-02P
:	:
24	TL220VA-24P

TL220RA

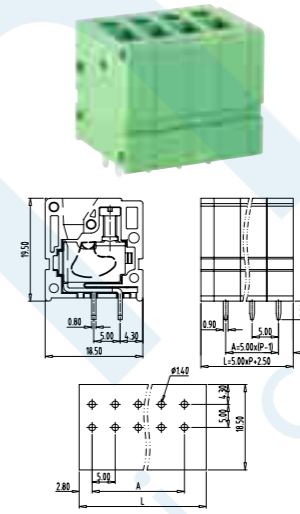

技术数据 Technical data	
Pitch (间距):	5.00mm
Approval (认证):	UL CE
Rated voltage (电压):	300V 320V
Rated current (电流):	20A 24A
Wire range (线径):	28-12AWG 0.34-2.5mm ²
PCB hole Dia(PCB直径):	Φ 1.40mm
Screw (螺丝):	M2.5
料号 Part Number	
极数 (Poles)	型号 (Model)
02	TL220RA-02P
:	:
24	TL220RA-24P

TL220VA-00P3

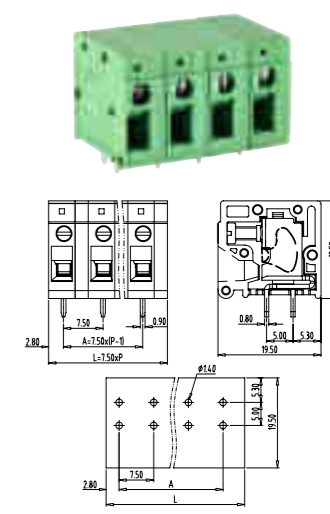

技术数据 Technical data	
Pitch (间距):	7.50mm
Approval (认证):	UL CE
Rated voltage (电压):	300V 630V
Rated current (电流):	20A 24A
Wire range (线径):	28-12AWG 0.34-2.5mm ²
PCB hole Dia(PCB直径):	Φ 1.40mm
Screw (螺丝):	M2.5
料号 Part Number	
极数 (Poles)	型号 (Model)
02	TL220VA-00P3-02P
:	:
24	TL220VA-00P3-24P

TL217V

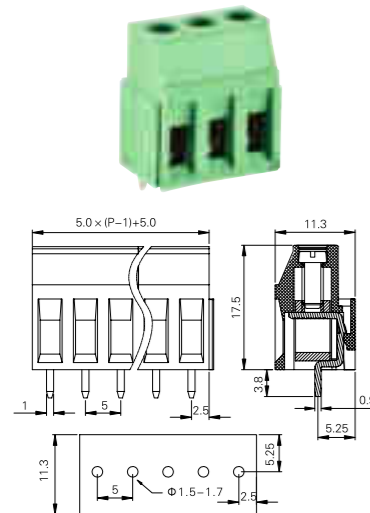

技术数据 Technical data	
Pitch (间距):	5.00mm
Approval (认证):	UL CE
Rated voltage (电压):	300V
Rated current (电流):	20A
Wire range (线径):	24-12AWG
PCB hole Dia(PCB直径):	Φ 1.5-1.7mm
Screw (螺丝):	M3
料号 Part Number	
极数 (Poles)	型号 (Model)
02	TL217V-02P
:	:
24	TL217V-24P

TL217R

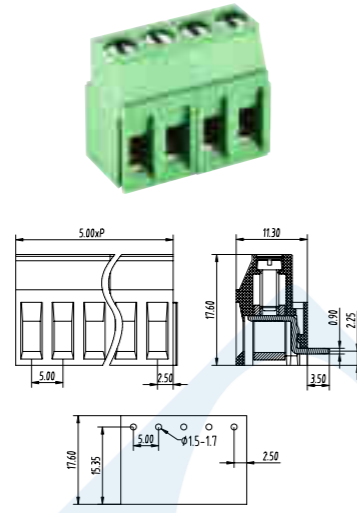

技术数据 Technical data	
Pitch (间距):	5.00mm
Approval (认证):	UL CE
Rated voltage (电压):	300V
Rated current (电流):	20A
Wire range (线径):	24-12AWG
PCB hole Dia(PCB直径):	Φ 1.5-1.7mm
Screw (螺丝):	M3
料号 Part Number	
极数 (Poles)	型号 (Model)
02	TL217R-02P
:	:
24	TL217R-24P

TL217RA

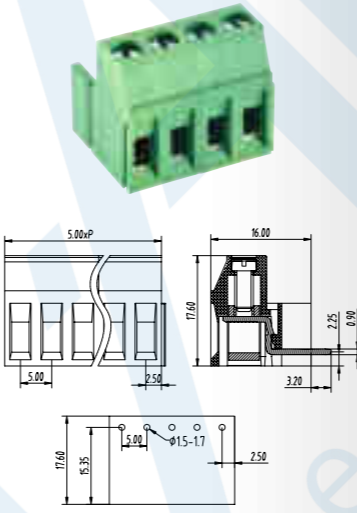

技术数据 Technical data	
Pitch (间距):	5.00mm
Approval (认证):	UL CE
Rated voltage (电压):	300V
Rated current (电流):	20A
Wire range (线径):	24-12AWG
PCB hole Dia(PCB直径):	Φ 1.5-1.7mm
Screw (螺丝):	M3
料号 Part Number	
极数 (Poles)	型号 (Model)
02	TL217RA-02P
:	:
24	TL217RA-24P

TL220RA-00P3

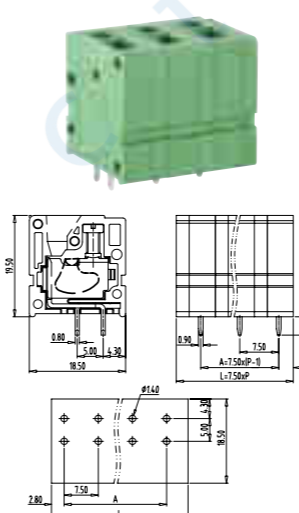

技术数据 Technical data	
Pitch (间距):	7.50mm
Approval (认证):	UL CE
Rated voltage (电压):	300V 630V
Rated current (电流):	20A 24A
Wire range (线径):	28-12AWG 0.34-2.5mm ²
PCB hole Dia(PCB直径):	Φ 1.40mm
Screw (螺丝):	M2.5
料号 Part Number	
极数 (Poles)	型号 (Model)
02	TL220RA-00P3-02P
:	:
24	TL220RA-00P3-24P

TL225V

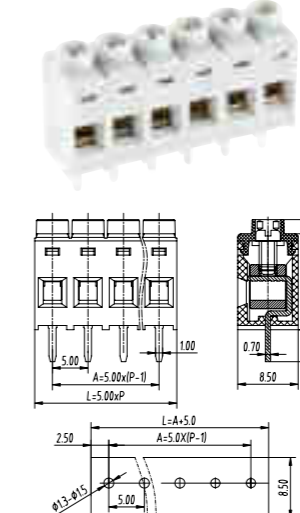

技术数据 Technical data	
Pitch (间距):	5.00mm
Approval (认证):	UL CE
Rated voltage (电压):	300V 320V
Rated current (电流):	16A 24A
Wire range (线径):	28-12AWG 0.2-2.5mm ² 4mm ² Sol
PCB hole Dia(PCB直径):	Φ 1.3-1.5mm
Screw (螺丝):	M2.5
料号 Part Number	
极数 (Poles)	型号 (Model)
02	TL225V-02P
:	:
24	TL225V-24P

TL225R

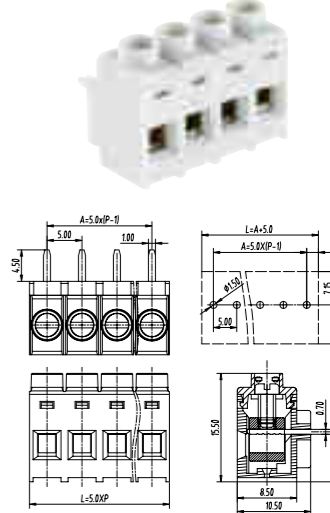

技术数据 Technical data	
Pitch (间距):	5.00mm
Approval (认证):	UL CE
Rated voltage (电压):	300V 320V
Rated current (电流):	16A 24A
Wire range (线径):	28-12AWG 0.2-2.5mm ² 4mm ² Sol
PCB hole Dia(PCB直径):	Φ 1.3-1.5mm
Screw (螺丝):	M2.5
料号 Part Number	
极数 (Poles)	型号 (Model)
02	TL225R-02P
:	:
24	TL225R-24P

TL414V-1511

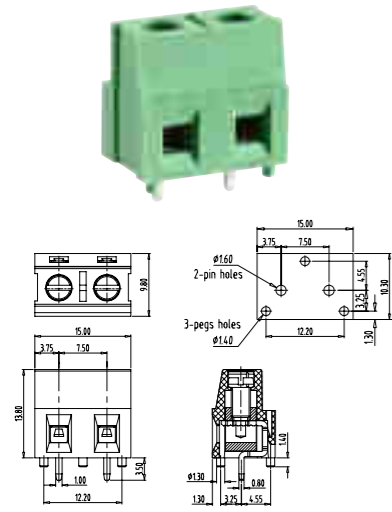

技术数据 Technical data	
Pitch (间距):	7.50mm
Approval (认证):	UL, CE, Ex, SR, CQC
Rated voltage (电压):	300V
Rated current (电流):	20A
Wire range (线径):	24-12AWG
Screw (螺丝):	M3

料号 Part Number	
极数 (Poles)	型号 (Model)
02	TL414V-1511-02P-02P
:	:
:	:

TL414R

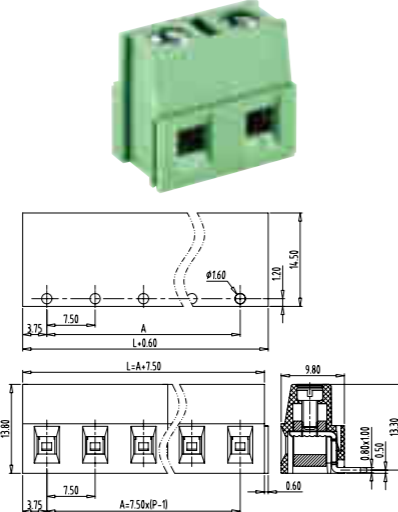

技术数据 Technical data	
Pitch (间距):	7.50mm
Approval (认证):	UL, CE, Ex, SR, CQC
Rated voltage (电压):	300V
Rated current (电流):	20A
Wire range (线径):	24-12AWG
Screw (螺丝):	M2.5

料号 Part Number	
极数 (Poles)	型号 (Model)
02	TL414R-02P
:	:
16	TL414R-16P

TL506V

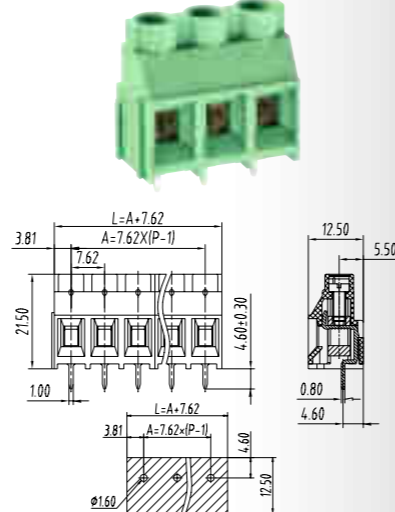

技术数据 Technical data	
Pitch (间距):	7.62mm
Approval (认证):	UL, CE, Ex, SR, CQC
Rated voltage (电压):	300V 630V
Rated current (电流):	30A 32A
Wire range (线径):	26-10AWG 4.0mm ²
PCB hole Dia(PCB直径):	Φ1.6mm
Screw (螺丝):	M3

料号 Part Number	
极数 (Poles)	型号 (Model)
02	TL506V-02P
:	:
24	TL506V-24P

TL802

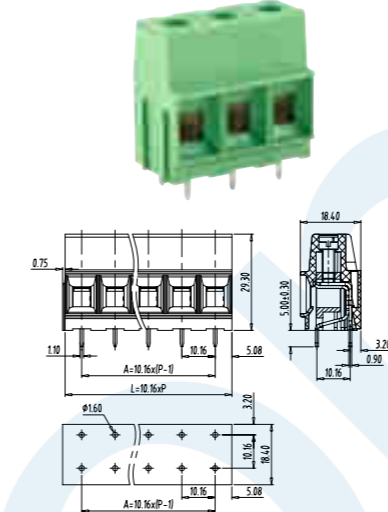

技术数据 Technical data	
Pitch (间距):	10.16mm
Approval (认证):	UL, CE, Ex, SR, CQC
Rated voltage (电压):	300V 630V
Rated current (电流):	65A 76A
Wire range (线径):	20-6AWG 0.5-16mm ²
PCB hole Dia(PCB直径):	Φ1.6mm
Screw (螺丝):	M4

料号 Part Number	
极数 (Poles)	型号 (Model)
02	TL802-02P
:	:
16	TL802-16P

TL802H

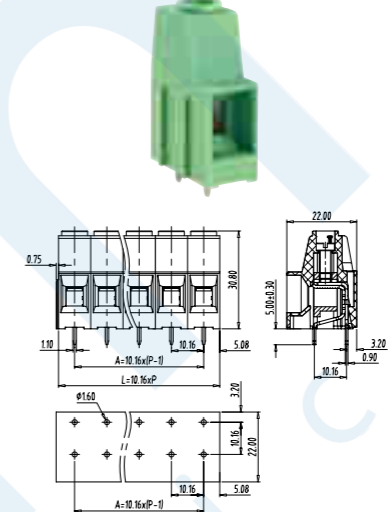

技术数据 Technical data	
Pitch (间距):	10.16mm
Approval (认证):	UL, CE, Ex, SR, CQC
Rated voltage (电压):	300V 630V
Rated current (电流):	65A 76A
Wire range (线径):	20-6AWG 0.5-16mm ²
PCB hole Dia(PCB直径):	Φ1.6mm
Screw (螺丝):	M4

料号 Part Number	
极数 (Poles)	型号 (Model)
02	TL802H-02P
:	:
16	TL802H-16P

TL802HS

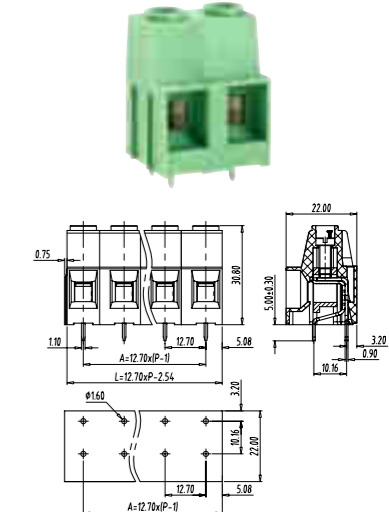

技术数据 Technical data	
Pitch (间距):	12.70mm
Approval (认证):	UL, CE, Ex, SR, CQC
Rated voltage (电压):	600V 1000V
Rated current (电流):	65A 76A
Wire range (线径):	20-6AWG 0.5-16mm ²
PCB hole Dia(PCB直径):	Φ1.6mm
Screw (螺丝):	M4

料号 Part Number	
极数 (Poles)	型号 (Model)
02	TL802HS-02P
:	:
16	TL802HS-16P

TL606V

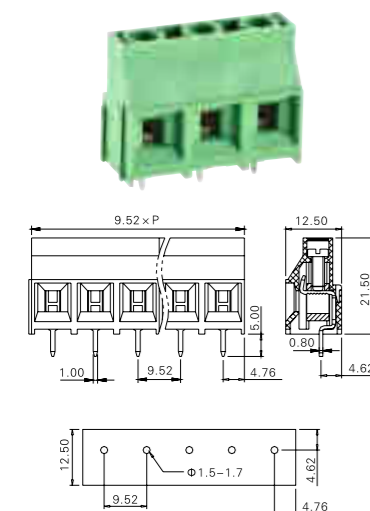

技术数据 Technical data	
Pitch (间距):	9.52mm
Approval (认证):	UL, CE, Ex, SR, CQC
Rated voltage (电压):	300V 1000V
Rated current (电流):	30A 32A
Wire range (线径):	26-10AWG 0.2-6.0mm ²
PCB hole Dia(PCB直径):	Φ1.5-1.7mm
Screw (螺丝):	M3

料号 Part Number	
极数 (Poles)	型号 (Model)
02	TL606V-02P
:	:
24	TL606V-24P

TL616

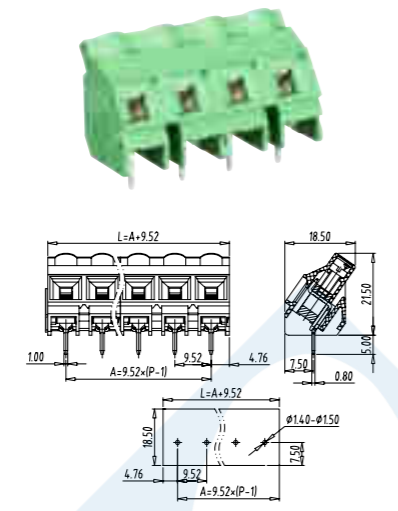

技术数据 Technical data	
Pitch (间距):	9.52mm
Approval (认证):	UL, CE, Ex, SR, CQC, VDE(Applying)
Rated voltage (电压):	300V 1000V
Rated current (电流):	30A 32A
Wire range (线径):	28-10AWG 0.2-4mm ² sol / str 6.0mm ² sol
PCB hole Dia(PCB直径):	Φ1.4-1.5mm
Screw (螺丝):	M3.0

料号 Part Number	
极数 (Poles)	型号 (Model)
02	TL616-02P
:	:
24	TL616-24P

TL800

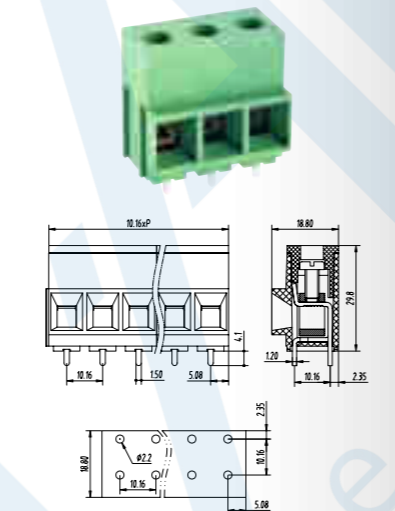

技术数据 Technical data	
Pitch (间距):	10.16mm
Approval (认证):	UL, CE, Ex, SR, CQC
Rated voltage (电压):	300V
Rated current (电流):	50A
Wire range (线径):	22-6AWG
PCB hole Dia(PCB直径):	Φ2.2mm
Screw (螺丝):	M4

料号 Part Number	
极数 (Poles)	型号 (Model)
02	TL800-02P
:	:
12	TL800-12P

TL804

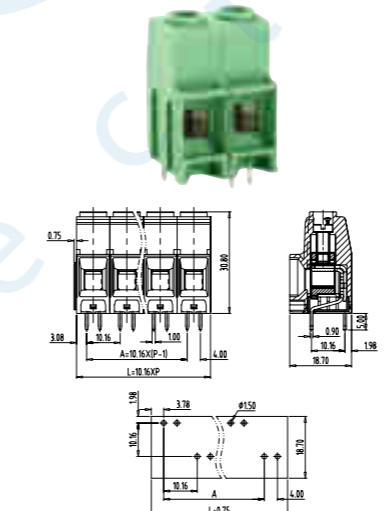

技术数据 Technical data	
Pitch (间距):	10.16mm
Approval (认证):	UL, CE, Ex, SR, CQC
Rated voltage (电压):	600V 1000V
Rated current (电流):	65A 76A
Wire range (线径):	20-6AWG 0.5-16mm ²
PCB hole Dia(PCB直径):	Φ1.5mm
Screw (螺丝):	M4

料号 Part Number	
极数 (Poles)	型号 (Model)
02	TL804-02P
:	:
16	TL804-16P

TL804S

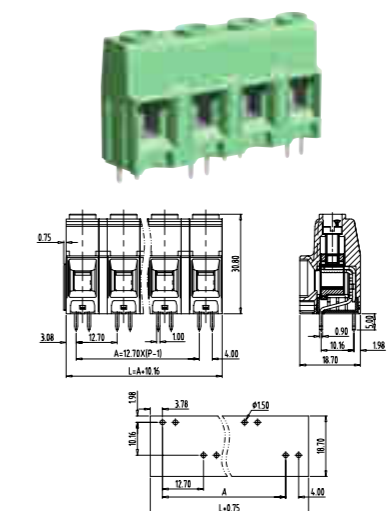

技术数据 Technical data	
Pitch (间距):	12.70mm
Approval (认证):	UL, CE, Ex, SR, CQC
Rated voltage (电压):	600V 1000V
Rated current (电流):	65A 76A
Wire range (线径):	20-6AWG 0.5-16mm ²
PCB hole Dia(PCB直径):	Φ1.5mm
Screw (螺丝):	M4

料号 Part Number	
极数 (Poles)	型号 (Model)
02	TL804S-02P
:	:
16	TL804S-16P

TL804S2

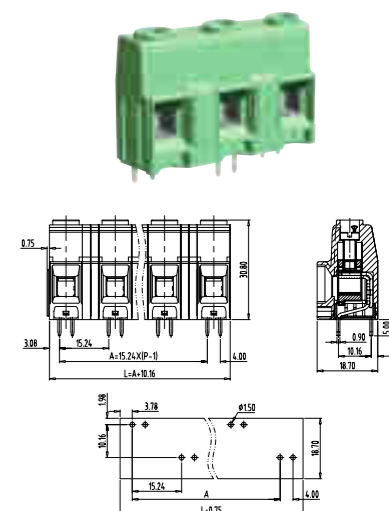

技术数据 Technical data	
Pitch (间距):	15.24mm
Approval (认证):	UL, CE, Ex, SR, CQC
Rated voltage (电压):	600V 1000V
Rated current (电流):	65A 76A
Wire range (线径):	20-6AWG 0.5-16mm ²
PCB hole Dia(PCB直径):	Φ1.5mm
Screw (螺丝):	M4

料号 Part Number	
极数 (Poles)	型号 (Model)
02	TL804S2-02P
:	:
16	TL804S2-16P

TL905

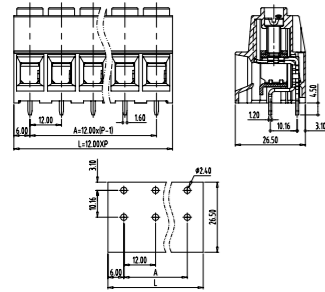

技术数据 Technical data	
Pitch (间距):	12.00mm
Approval (认证):	UL VDE(Applying)
Rated voltage (电压):	600V 1000V
Rated current (电流):	85A 101A
Wire range (线径):	20-4AWG 0.5-25mm ²
PCB hole Dia(PCB 直径):	Φ 2.40mm
Screw (螺丝):	M5
料号 Part Number	
极数 (Poles)	型号 (Model)
02	TL905-02P
:	:
16	TL905-16P

TL903

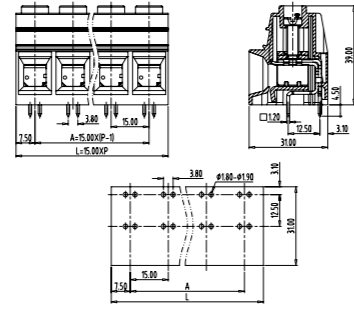

技术数据 Technical data	
Pitch (间距):	15.00mm
Approval (认证):	UL VDE
Rated voltage (电压):	600V 1000V
Rated current (电流):	120A 125A
Wire range (线径):	20-2AWG 0.5-35mm ²
PCB hole Dia(PCB 直径):	Φ 1.8mm-Φ 1.9mm
Screw (螺丝):	M5
料号 Part Number	
极数 (Poles)	型号 (Model)
02	TL903-02P
:	:
12	TL903-12P

TL903M

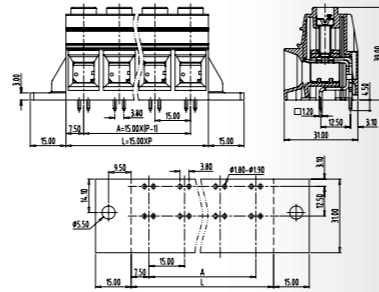

技术数据 Technical data	
Pitch (间距):	15.00mm
Approval (认证):	UL VDE
Rated voltage (电压):	600V 1000V
Rated current (电流):	120A 125A
Wire range (线径):	20-2AWG 0.5-35mm ²
PCB hole Dia(PCB 直径):	Φ 1.8mm-1.9mm
Screw (螺丝):	M5
料号 Part Number	
极数 (Poles)	型号 (Model)
02	TL903M-02P
:	:
10	TL903M-10P

TLD200(TLD300)

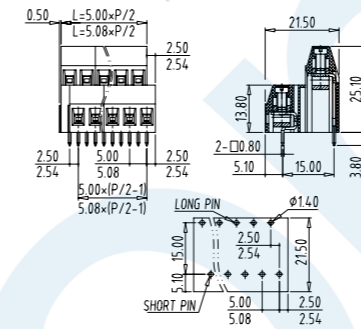

技术数据 Technical data	
Pitch (间距):	5.00mm(5.08mm)
Approval (认证):	UL VDE
Rated voltage (电压):	300V
Rated current (电流):	10A
Wire range (线径):	30-14AWG
PCB hole Dia(PCB 直径):	Φ 1.4-1.5mm
Screw (螺丝):	M3
料号 Part Number	
极数 (Poles)	型号 (Model)
04	TLD200-04P(TLD300-04P)
:	:
48	TLD200-48P(TLD300-48P)

TLD201(TLD301)

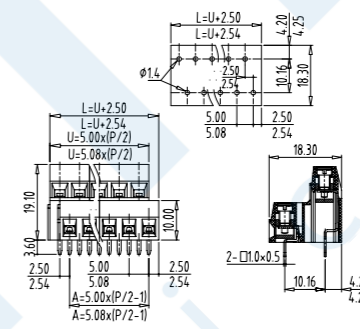

技术数据 Technical data	
Pitch (间距):	5.00mm(5.08mm)
Approval (认证):	UL VDE
Rated voltage (电压):	300V 320V
Rated current (电流):	10A 14A
Wire range (线径):	30-14AWG
PCB hole Dia(PCB 直径):	Φ 1.4-1.5mm
Screw (螺丝):	M3
料号 Part Number	
极数 (Poles)	型号 (Model)
04	TLD201-04P(TLD301-04P)
:	:
48	TLD201-48P(TLD301-48P)

TL324V

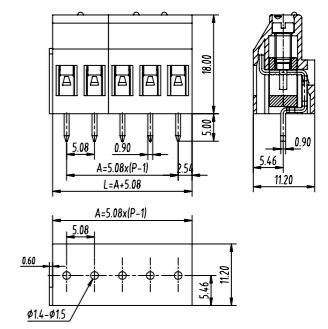
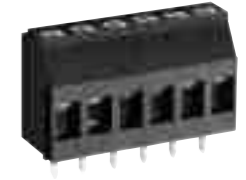

技术数据 Technical data	
Pitch (间距):	5.08mm
Approval (认证):	UL VDE
Rated voltage (电压):	300V
Rated current (电流):	25A
Wire range (线径):	28-10AWG
PCB hole Dia(PCB 直径):	Φ 1.4-1.5mm
Screw (螺丝):	M3
料号 Part Number	
极数 (Poles)	型号 (Model)
02	TL324V-02P
:	:
24	TL324V-24P

TL903ML

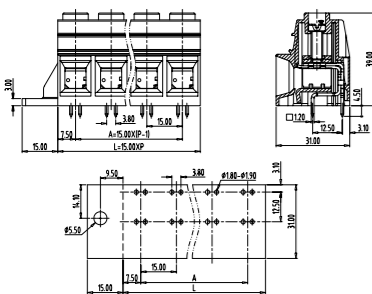

技术数据 Technical data	
Pitch (间距):	15.00mm
Approval (认证):	UL VDE
Rated voltage (电压):	600V 1000V
Rated current (电流):	120A 125A
Wire range (线径):	20-2AWG 0.5-35mm ²
PCB hole Dia(PCB 直径):	Φ 1.8mm-1.9mm
Screw (螺丝):	M5
料号 Part Number	
极数 (Poles)	型号 (Model)
01	TL903ML-01P
:	:
10	TL903ML-10P

TL903MR

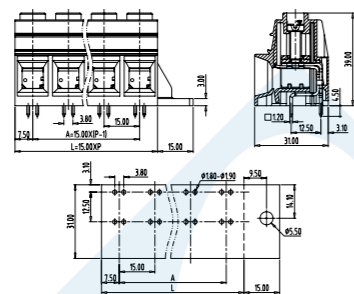

技术数据 Technical data	
Pitch (间距):	15.00mm
Approval (认证):	UL VDE
Rated voltage (电压):	600V 1000V
Rated current (电流):	120A 125A
Wire range (线径):	20-2AWG 0.5-35mm ²
PCB hole Dia(PCB 直径):	Φ 1.8mm-1.9mm
Screw (螺丝):	M5
料号 Part Number	
极数 (Poles)	型号 (Model)
01	TL903MR-01P
:	:
10	TL903MR-10P

TLD001(TLD100)

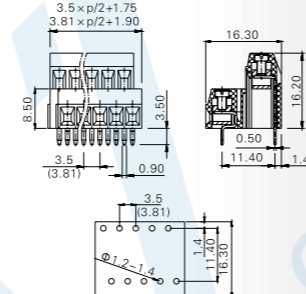

技术数据 Technical data	
Pitch (间距):	3.50mm(3.81mm)
Approval (认证):	UL VDE
Rated voltage (电压):	300V
Rated current (电流):	10A
Wire range (线径):	22-14AWG
PCB hole Dia(PCB 直径):	Φ 1.2-1.4mm
Screw (螺丝):	M2
料号 Part Number	
极数 (Poles)	型号 (Model)
04	TLD001-04P(TLD100-04P)
:	:
48	TLD001-48P(TLD100-48P)

TL324VM

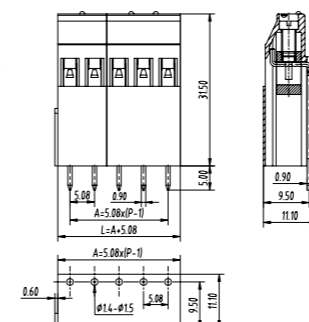

技术数据 Technical data	
Pitch (间距):	5.08mm
Approval (认证):	UL VDE
Rated voltage (电压):	300V
Rated current (电流):	25A
Wire range (线径):	28-10AWG
PCB hole Dia(PCB 直径):	Φ 1.4-1.5mm
Screw (螺丝):	M3
料号 Part Number	
极数 (Poles)	型号 (Model)
02	TL324VM-02P
:	:
24	TL324VM-24P

TL324VH

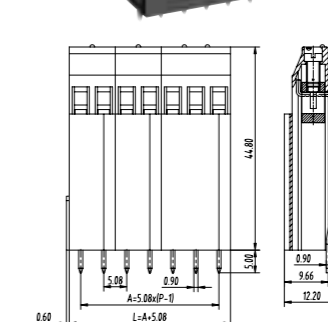

技术数据 Technical data	
Pitch (间距):	5.08mm
Approval (认证):	UL VDE
Rated voltage (电压):	300V
Rated current (电流):	25A
Wire range (线径):	28-10AWG
PCB hole Dia(PCB 直径):	Φ 1.4-1.5mm
Screw (螺丝):	M3
料号 Part Number	
极数 (Poles)	型号 (Model)
02	TL324VH-02P
:	:
24	TL324VH-24P

TL324VM2

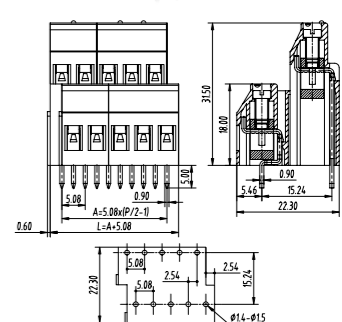

技术数据 Technical data	
Pitch (间距):	5.08mm
Approval (认证):	UL VDE
Rated voltage (电压):	300V
Rated current (电流):	25A
Wire range (线径):	28-10AWG
PCB hole Dia(PCB 直径):	Φ 1.4-1.5mm
Screw (螺丝):	M3
料号 Part Number	
极数 (Poles)	型号 (Model)
04	TL324VM2-04P
:	:
48	TL324VM2-48P

TL324VH2

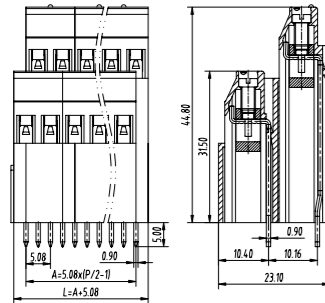

技术数据 Technical data	
Pitch (间距):	5.08mm
Approval (认证):	UL, VDE(Applying)
Rated voltage (电压):	300V
Rated current (电流):	25A
Wire range (线径):	28–10AWG
PCB hole Dia(PCB 直径):	Φ 1.4–1.5mm
Screw (螺丝):	M3.0
料号 Part Number	
极数 (Poles)	型号 (Model)
04	TL324VH2–04P
:	:
48	TL324VH2–48P

TL324VH3

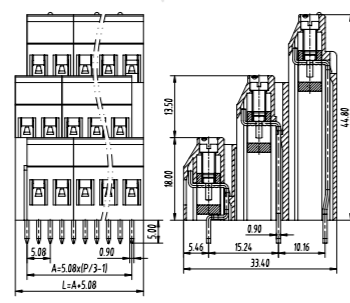

技术数据 Technical data	
Pitch (间距):	5.08mm
Approval (认证):	UL, VDE(Applying)
Rated voltage (电压):	300V
Rated current (电流):	25A
Wire range (线径):	28–10AWG
PCB hole Dia(PCB 直径):	Φ 1.4–1.5mm
Screw (螺丝):	M3.0
料号 Part Number	
极数 (Poles)	型号 (Model)
06	TL324VH3–06P
:	:
72	TL324VH3–72P

TL332VM

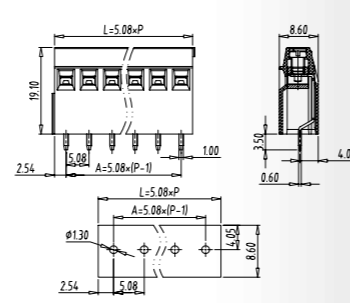

技术数据 Technical data	
Pitch (间距):	5.08mm
Approval (认证):	UL, VDE(Applying)
Rated voltage (电压):	300V 320V
Rated current (电流):	12A 14A
Wire range (线径):	30–14AWG 0.2–1.5mm ²
Screw (螺丝):	M3
料号 Part Number	
极数 (Poles)	型号 (Model)
02	TL332VM–02P
:	:
24	TL332VM–24P

TL338VM

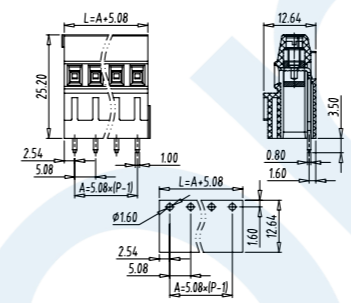

技术数据 Technical data	
Pitch (间距):	5.08mm
Approval (认证):	UL, VDE(Applying)
Rated voltage (电压):	300V 320V
Rated current (电流):	20A 24A
Wire range (线径):	28–12AWG 0.2–2.5mm ²
Screw (螺丝):	M3
料号 Part Number	
极数 (Poles)	型号 (Model)
02	TL338VM–02P
:	:
24	TL338VM–24P

TL338VH

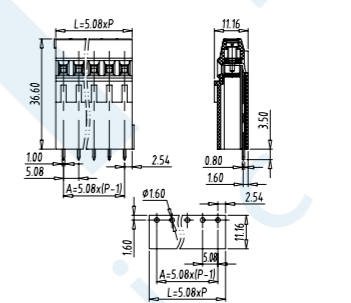

技术数据 Technical data	
Pitch (间距):	5.08mm
Approval (认证):	UL, VDE(Applying)
Rated voltage (电压):	300V 320V
Rated current (电流):	20A 24A
Wire range (线径):	28–12AWG 0.2–2.5mm ²
Screw (螺丝):	M3.0
料号 Part Number	
极数 (Poles)	型号 (Model)
02	TL338VH–02P
:	:
24	TL338VH–24P

TL338VM2L

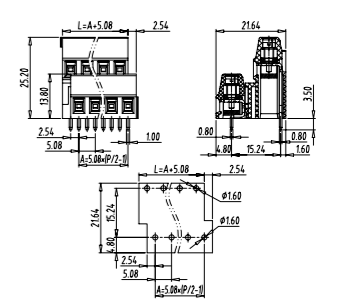
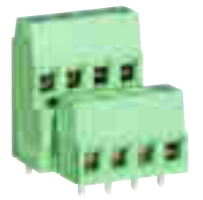

技术数据 Technical data	
Pitch (间距):	5.08mm
Approval (认证):	UL, VDE(Applying)
Rated voltage (电压):	300V 320V
Rated current (电流):	20A 18A
Wire range (线径):	28–12AWG 0.2–2.5mm ²
Screw (螺丝):	M3.0
料号 Part Number	
极数 (Poles)	型号 (Model)
04	TL338VM2L–04P
:	:
48	TL338VM2L–48P

TL332VH2

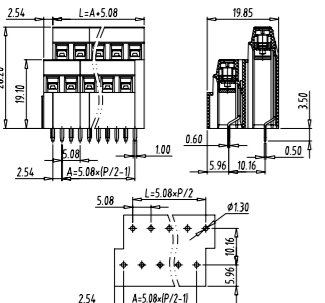

技术数据 Technical data	
Pitch (间距):	5.08mm
Approval (认证):	UL, VDE(Applying)
Rated voltage (电压):	300V 320V
Rated current (电流):	12A 10A
Wire range (线径):	30–14AWG 0.2–1.5mm ²
Screw (螺丝):	M3
料号 Part Number	
极数 (Poles)	型号 (Model)
04	TL332VH2–04P
:	:
48	TL332VH2–48P

TL332VH3

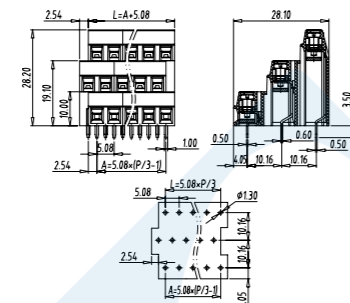

技术数据 Technical data	
Pitch (间距):	5.08mm
Approval (认证):	UL, VDE(Applying)
Rated voltage (电压):	300V 320V
Rated current (电流):	12A 10A
Wire range (线径):	30–14AWG 0.2–1.5mm ²
Screw (螺丝):	M3
料号 Part Number	
极数 (Poles)	型号 (Model)
06	TL332VH3–06P
:	:
72	TL332VH3–72P

TL338V

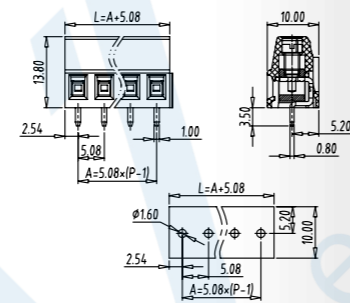

技术数据 Technical data	
Pitch (间距):	5.08mm
Approval (认证):	UL, VDE(Applying)
Rated voltage (电压):	300V 320V
Rated current (电流):	20A 24A
Wire range (线径):	28–12AWG 0.2–2.5mm ²
Screw (螺丝):	M3
料号 Part Number	
极数 (Poles)	型号 (Model)
02	TL338V–02P
:	:
24	TL338V–24P

TL338VM2R

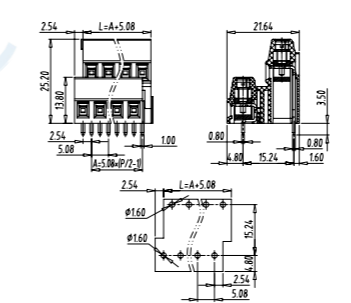
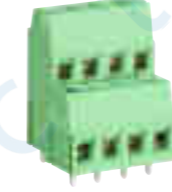

技术数据 Technical data	
Pitch (间距):	5.08mm
Approval (认证):	UL, VDE(Applying)
Rated voltage (电压):	300V 320V
Rated current (电流):	20A 18A
Wire range (线径):	28–12AWG 0.2–2.5mm ²
Screw (螺丝):	M3.0
料号 Part Number	
极数 (Poles)	型号 (Model)
04	TL338VM2R–04P
:	:
48	TL338VM2R–48P

TL338VH2L

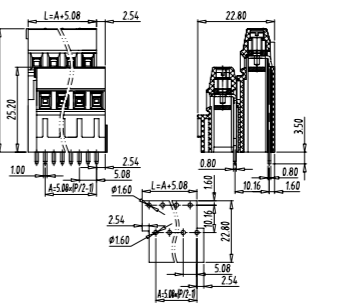

技术数据 Technical data	
Pitch (间距):	5.08mm
Approval (认证):	UL, VDE(Applying)
Rated voltage (电压):	300V 320V
Rated current (电流):	20A 18A
Wire range (线径):	28–12AWG 0.2–2.5mm ²
Screw (螺丝):	M3.0
料号 Part Number	
极数 (Poles)	型号 (Model)
04	TL338VH2L–04P
:	:
48	TL338VH2L–48P

TL338VH2R

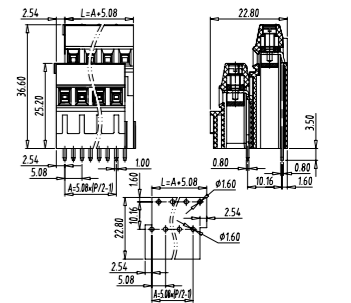

技术数据 Technical data	
Pitch (间距):	5.08mm
Approval (认证):	UL, VDE(Applying)
Rated voltage (电压):	300V 320V
Rated current (电流):	20A 18A
Wire range (线径):	28–12AWG 0.2–2.5mm ²
Screw (螺丝):	M3.0
料号 Part Number	
极数 (Poles)	型号 (Model)
04	TL338VH2R–04P
:	:
48	TL338VH2R–48P

TL338VH3L

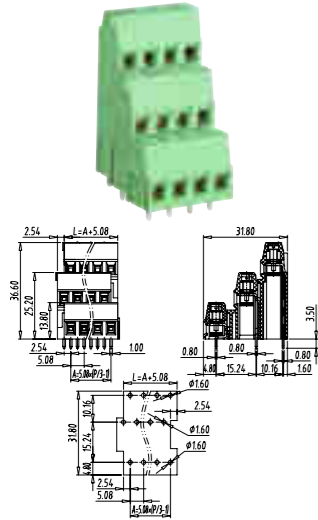

技术数据 Technical data	
Pitch (间距):	5.08mm
Approval (认证):	UL VDE(Applying)
Rated voltage (电压):	300V 320V
Rated current (电流):	20A 18A
Wire range (线径):	28-12AWG 0.2-2.5mm ²
Screw (螺丝):	M3.0

料号 Part Number	
极数 (Poles)	型号 (Model)
06	TL338VH3L-06P
:	:
72	TL338VH3L-72P

TL338VH3R

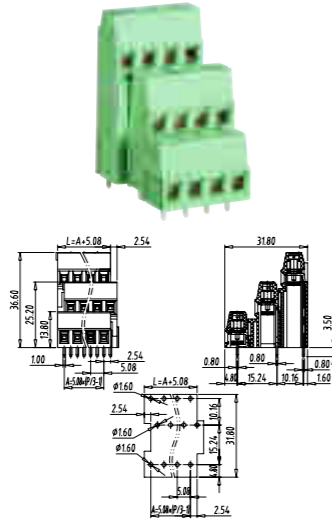

技术数据 Technical data	
Pitch (间距):	5.08mm
Approval (认证):	UL VDE(Applying)
Rated voltage (电压):	300V 320V
Rated current (电流):	20A 18A
Wire range (线径):	28-12AWG 0.2-2.5mm ²
Screw (螺丝):	M3.0

料号 Part Number	
极数 (Poles)	型号 (Model)
06	TL338VH3R-06P
:	:
72	TL338VH3R-72P

TLB21-001

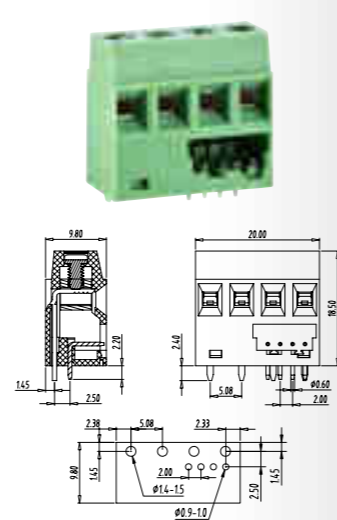

技术数据 Technical data	
Pitch (间距):	2.0mm, 5.08mm
Rated voltage (电压):	50V
Rated current (S.S):	10A/3A
Wire range (线径):	26-16AWG
PCB hole Dia(PCB 直径):	Φ1.4-1.5mm/Φ1.0mm
Screw (螺丝):	M2.5

料号 Part Number	
极数 (Poles)	型号 (Model)
-	TLB21-001

TLB21-003

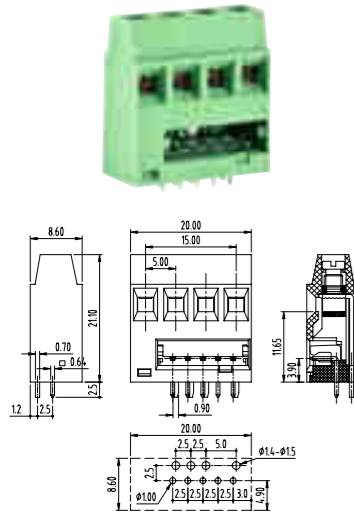

技术数据 Technical data	
Pitch (间距):	2.50mm, 5.0mm
Rated voltage (电压):	150V
Rated current (电流):	15A/5A
Wire range (线径):	26-14AWG
PCB hole Dia(PCB 直径):	Φ1.4-1.5mm/Φ1.0mm
Screw (螺丝):	M3.0

料号 Part Number	
极数 (Poles)	型号 (Model)
-	TLB21-003

TLM SERIES – PCB Spring Terminal Block

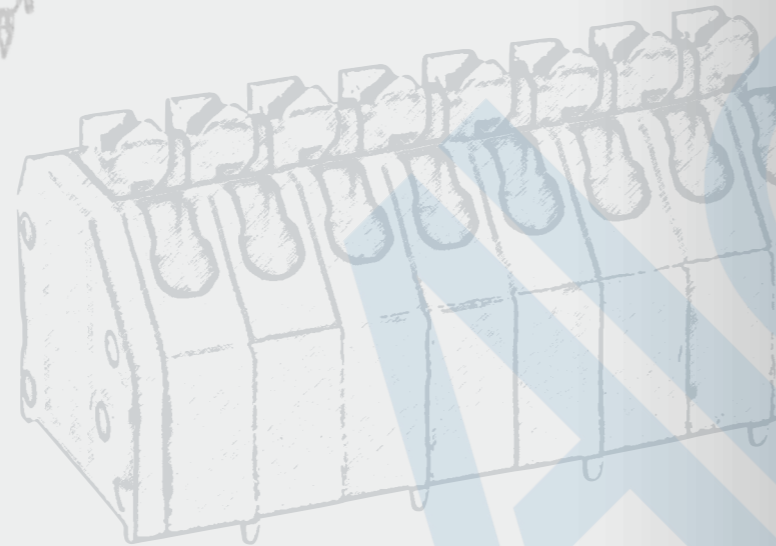
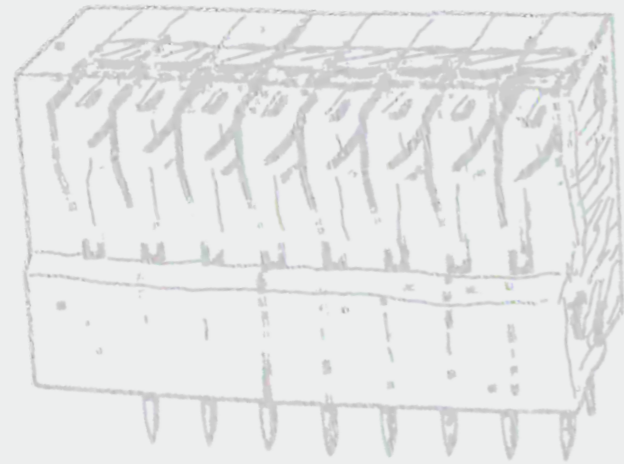

How to order

TLM C/D/V/R - - P -

- Color: M=Gray, G(G12)=Green
- 5=Double pitch, None=Standard pitch
- Poles
- Special code
- C=Long pin near to side cover, D=Short pin near to side cover, V=180°, R=90°
- Series number
- Pitch: 0=3.50, 1=3.81, 2=5.00, 3=5.08, 4=7.50, 5=7.62, 6=9.52, 7=10.00, 8=10.16, 9=2.54

TLM-004VT-3.50(TLM-004VT-3.81)

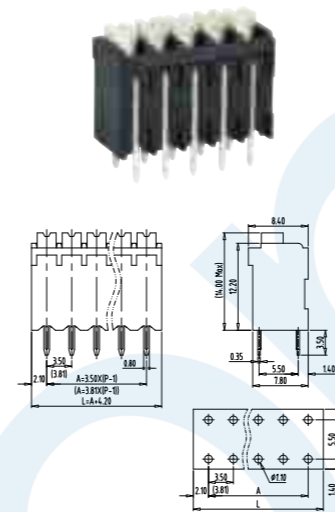

技术数据 Technical data	
Pitch (间距):	3.50mm(3.81mm)
Approval (认证):	
Rated voltage (电压):	300V 160V
Rated current (电流):	12A 17.5A
Wire range (线径):	28-16AWG 0.2-1.5mm ²
PCB holeDia(PCB直径):	Φ 1.1mm
料号 Part Number	
极数 (Poles)	型号 (Model)
02	TLM-004VT-3.50-02P(TLM-004VT-3.81-02P)
:	:
24	TLM-004VT-3.50-24P(TLM-004VT-3.81-24P)

TLM-004VT-5.00(TLM-004VT-5.08)

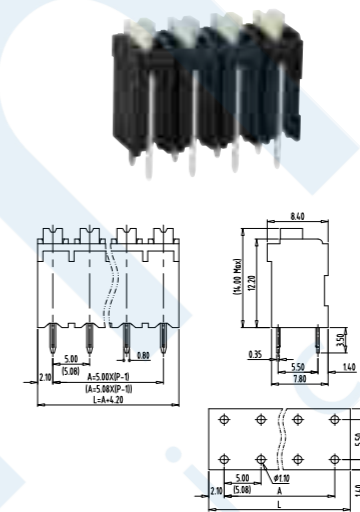

技术数据 Technical data	
Pitch (间距):	5.00mm(5.08mm)
Approval (认证):	
Rated voltage (电压):	300V 320V
Rated current (电流):	12A 17.5A
Wire range (线径):	28-16AWG 0.2-1.5mm ²
PCB holeDia(PCB直径):	Φ 1.1mm
料号 Part Number	
极数 (Poles)	型号 (Model)
02	TLM-004VT-5.00-02P(TLM-004VT-5.08-02P)
:	:
24	TLM-004VT-5.00-24P(TLM-004VT-5.08-24P)

TLM-004VT-7.62

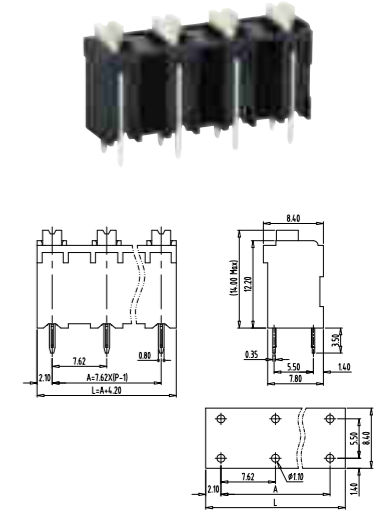

技术数据 Technical data	
Pitch (间距):	7.62mm
Approval (认证):	
Rated voltage (电压):	300V 630V
Rated current (电流):	12A 17.5A
Wire range (线径):	28-16AWG 0.2-1.5mm ²
PCB holeDia(PCB直径):	Φ 1.1mm
料号 Part Number	
极数 (Poles)	型号 (Model)
02	TLM-004VT-7.62-02P
:	:
16	TLM-004VT-7.62-16P

TLM-004RT-3.50(TLM-004RT-3.81)

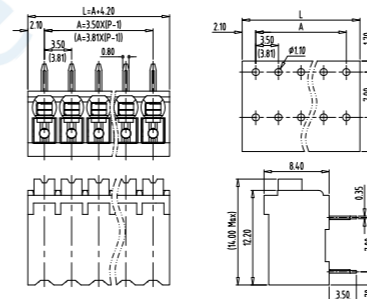

技术数据 Technical data	
Pitch (间距):	3.50mm(3.81mm)
Approval (认证):	
Rated voltage (电压):	300V 160V
Rated current (电流):	10A 17.5A
Wire range (线径):	28-16AWG 0.2-1.5mm ²
PCB hole Dia(PCB直径):	Φ 1.1mm
料号 Part Number	
极数 (Poles)	型号 (Model)
02	TLM-004RT-3.50-02P(TLM-004RT-3.81-02P)
:	:
24	TLM-004RT-3.50-24P(TLM-004RT-3.81-24P)

TLM-004RT-5.00(TLM-004RT-5.08)

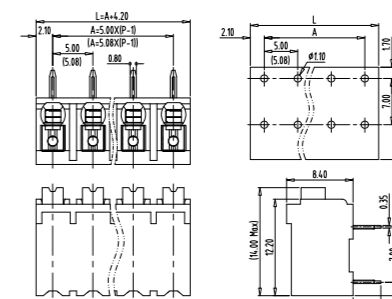

技术数据 Technical data	
Pitch (间距):	5.00mm(5.08mm)
Approval (认证):	
Rated voltage (电压):	300V 320V
Rated current (电流):	12A 17.5A
Wire range (线径):	28-16AWG 0.2-1.5mm ²
PCB hole Dia(PCB直径):	Φ 1.1mm
料号 Part Number	
极数 (Poles)	型号 (Model)
02	TLM-004RT-5.00-02P(TLM-004RT-5.08-02P)
:	:
24	TLM-004RT-5.00-24P(TLM-004RT-5.08-24P)

TLM-004RT-7.62 THR

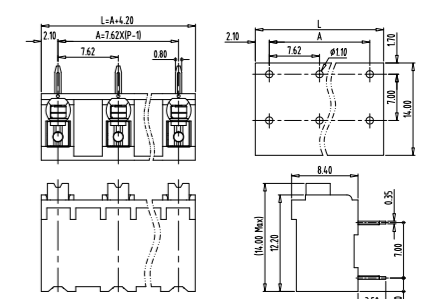
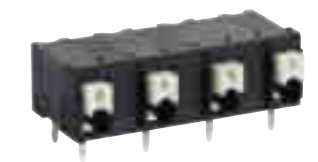

技术数据 Technical data	
Pitch (间距):	7.62mm
Approval (认证):	
Rated voltage (电压):	300V 630V
Rated current (电流):	12A 17.5A
Wire range (线径):	28-16AWG 0.2-1.5mm ²
PCB hole Dia(PCB直径):	Φ 1.1mm
料号 Part Number	
极数 (Poles)	型号 (Model)
02	TLM-004RT-7.62-02P
:	:
16	TLM-004RT-7.62-16P

TLM-004AT-3.50(TLM-004AT-3.81)

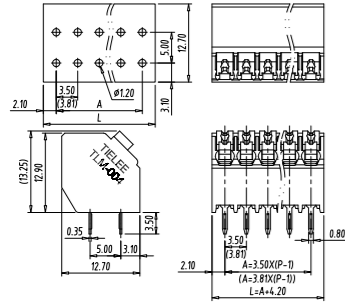

技术数据 Technical data	
Pitch (间距):	3.50mm(3.81mm)
Approval (认证):	
Rated voltage (电压):	300V 160V
Rated current (电流):	12A 17.5A
Wire range (线径):	28-16AWG 0.2-1.5mm ²
PCB hole Dia(PCB直径):	Φ 1.2mm
料号 Part Number	
极数 (Poles)	型号 (Model)
02	TLM-004AT-3.50-02P(TLM-004AT-3.81-02P)
:	:
24	TLM-004AT-3.50-24P(TLM-004AT-3.81-24P)

TLM-004AT-5.00(TLM-004AT-5.08)

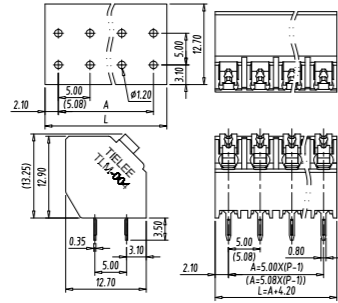

技术数据 Technical data	
Pitch (间距):	5.00mm(5.08mm)
Approval (认证):	
Rated voltage (电压):	300V 320V
Rated current (电流):	12A 17.5A
Wire range (线径):	28-16AWG 0.2-1.5mm ²
PCB hole Dia(PCB直径):	Φ 1.2mm
料号 Part Number	
极数 (Poles)	型号 (Model)
02	TLM-004AT-5.00-02P(TLM-004AT-5.08-02P)
:	:
24	TLM-004AT-5.00-24P(TLM-004AT-5.08-24P)

TLM-004AT-7.62

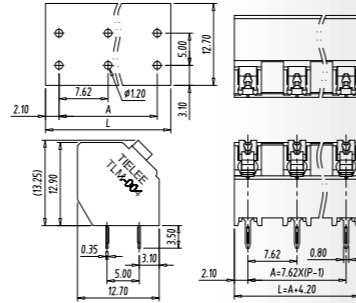

技术数据 Technical data	
Pitch (间距):	7.62mm
Approval (认证):	
Rated voltage (电压):	300V 630V
Rated current (电流):	12A 17.5A
Wire range (线径):	28-16AWG 0.2-1.5mm ²
PCB hole Dia(PCB直径):	Φ 1.2mm
料号 Part Number	
极数 (Poles)	型号 (Model)
02	TLM-004AT-7.62-02P
:	:
16	TLM-004AT-7.62-16P

TLM-004RS-3.50(TLM-004RS-3.81)

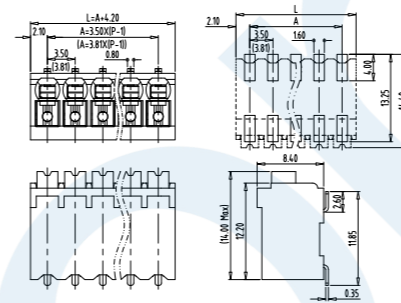

技术数据 Technical data	
Pitch (间距):	3.50mm(3.81mm)
Approval (认证):	
Rated voltage (电压):	300V 160V
Rated current (电流):	12A 17.5A
Wire range (线径):	28-16AWG 0.2-1.5mm ²
料号 Part Number	
极数 (Poles)	型号 (Model)
02	TLM-004RS-3.50-02P(TLM-004RS-3.81-02P)
:	:
24	TLM-004RS-3.50-24P(TLM-004RS-3.81-24P)

TLM-004RS-5.00(TLM-004RS-5.08)

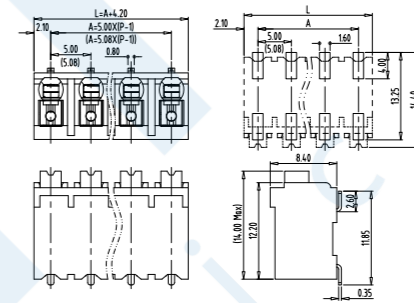

技术数据 Technical data	
Pitch (间距):	5.00mm(5.08mm)
Approval (认证):	
Rated voltage (电压):	300V 320V
Rated current (电流):	12A 17.5A
Wire range (线径):	28-16AWG 0.2-1.5mm ²
料号 Part Number	
极数 (Poles)	型号 (Model)
02	TLM-004RS-5.00-02P(TLM-004RS-5.08-02P)
:	:
24	TLM-004RS-5.00-24P(TLM-004RS-5.08-24P)

TLM-004RS-7.62

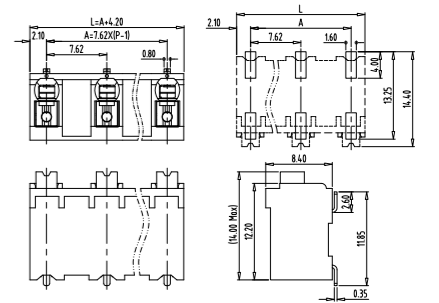

技术数据 Technical data	
Pitch (间距):	7.62mm
Approval (认证):	
Rated voltage (电压):	300V 630V
Rated current (电流):	12A 17.5A
Wire range (线径):	28-16AWG 0.2-1.5mm ²
料号 Part Number	
极数 (Poles)	型号 (Model)
02	TLM-004RS-7.62-02P
:	:
16	TLM-004RS-7.62-16P

TLM-004VS-3.50(TLM-004VS-3.81)

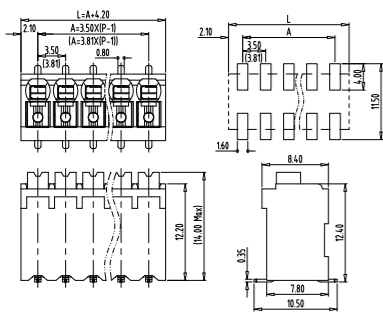

技术数据 Technical data	
Pitch (间距):	3.50mm(3.81mm)
Approval (认证):	
Rated voltage (电压):	300V 320V
Rated current (电流):	12A 17.5A
Wire range (线径):	28-16AWG 0.2-1.5mm ²
料号 Part Number	
极数 (Poles)	型号 (Model)
02	TLM-004VS-3.50-02P(TLM-004VS-3.81-02P)
:	:
24	TLM-004VS-3.50-24P(TLM-004VS-3.81-24P)

TLM-004VS-5.00(TLM-004VS-5.08)

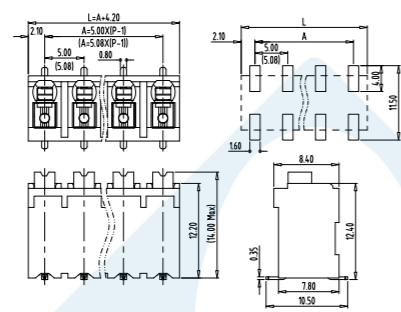

技术数据 Technical data	
Pitch (间距):	5.00mm(5.08mm)
Approval (认证):	
Rated voltage (电压):	300V 320V
Rated current (电流):	12A 17.5A
Wire range (线径):	28-16AWG 0.2-1.5mm ²
料号 Part Number	
极数 (Poles)	型号 (Model)
02	TLM-004VS-5.00-02P(TLM-004VS-5.08-02P)
:	:
24	TLM-004VS-5.00-24P(TLM-004VS-5.08-24P)

TLM-004VS-7.62

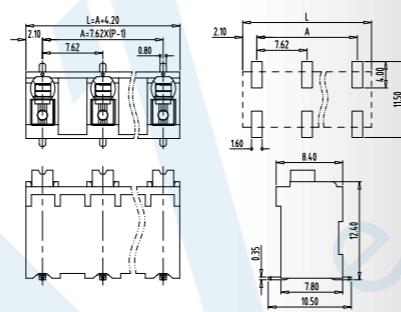

技术数据 Technical data	
Pitch (间距):	7.62mm
Approval (认证):	
Rated voltage (电压):	300V 630V
Rated current (电流):	12A 17.5A
Wire range (线径):	28-16AWG 0.2-1.5mm ²
料号 Part Number	
极数 (Poles)	型号 (Model)
02	TLM-004VS-7.62-02P
:	:
24	TLM-004VS-7.62-24P

TLM-004AS-3.50(TLM-004AS-3.81)

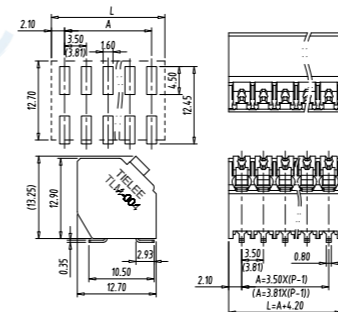

技术数据 Technical data	
Pitch (间距):	3.50mm(3.81mm)
Approval (认证):	
Rated voltage (电压):	300V 160V
Rated current (电流):	12A 17.5A
Wire range (线径):	28-16AWG 0.2-1.5mm ²
料号 Part Number	
极数 (Poles)	型号 (Model)
02	TLM-004AS-3.50-02P(TLM-004AS-3.81-02P)
:	:
24	TLM-004AS-3.50-24P(TLM-004AS-3.81-24P)

TLM-004AS-5.00(TLM-004AS-5.08)

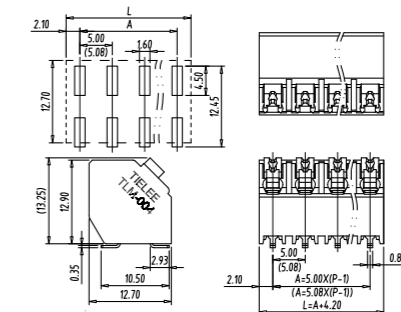

技术数据 Technical data	
Pitch (间距):	5.00mm(5.08mm)
Approval (认证):	
Rated voltage (电压):	300V 320V
Rated current (电流):	12A 17.5A
Wire range (线径):	28-16AWG 0.2-1.5mm ²
料号 Part Number	
极数 (Poles)	型号 (Model)
02	TLM-004AS-5.00-02P(TLM-004AS-5.08-02P)
:	:
24	TLM-004AS-5.00-24P(TLM-004AS-5.08-24P)

TLM-004AS-7.62

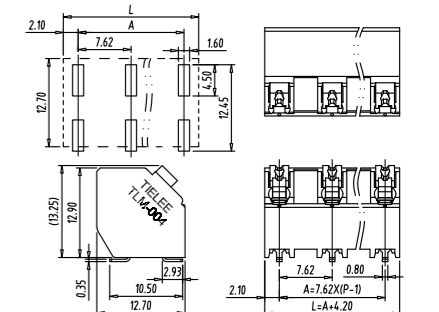

技术数据 Technical data	
Pitch (间距):	7.62mm
Approval (认证):	
Rated voltage (电压):	300V 630V
Rated current (电流):	12A 17.5A
Wire range (线径):	28-16AWG 0.2-1.5mm ²
料号 Part Number	
极数 (Poles)	型号 (Model)
02	TLM-004AS-7.62-02P
:	:
16	TLM-004AS-7.62-16P

TLM-006-3.50

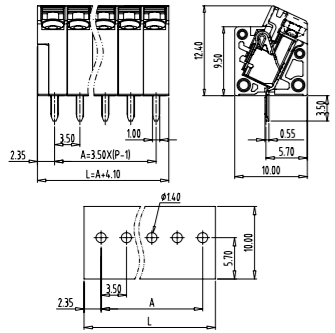
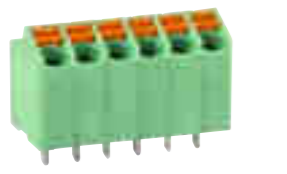

技术数据 Technical data	
Pitch (间距):	3.50mm
Approval (认证):	
Rated voltage (电压):	300V 160V
Rated current (电流):	10A 17.5A
Wire range (线径):	26-16AWG 0.2-1.5mm ²
PCB hole Dia(PCB直径):	Φ 1.4mm
料号 Part Number	
极数 (Poles)	型号 (Model)
02	TLM-006-3.50-02P
:	:
24	TLM-006-3.50-24P

TLM-006-5.00

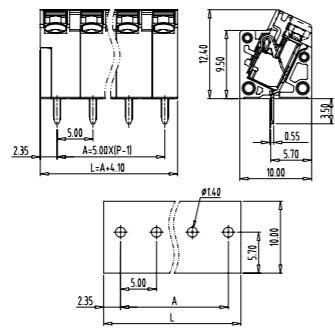
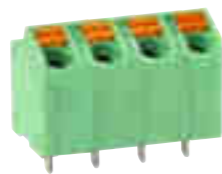

技术数据 Technical data	
Pitch (间距):	5.00mm
Approval (认证):	
Rated voltage (电压):	300V 320V
Rated current (电流):	10A 17.5A
Wire range (线径):	26-16AWG 0.2-1.5mm ²
PCB hole Dia(PCB直径):	Φ 1.4mm
料号 Part Number	
极数 (Poles)	型号 (Model)
02	TLM-006-5.00-02P
:	:
16	TLM-006-5.00-16P

TLM-006A-3.81

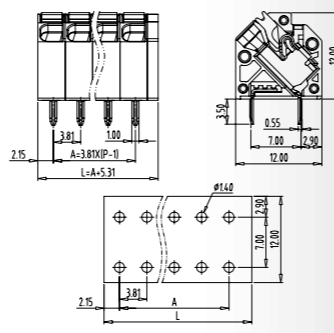
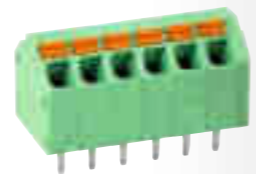

技术数据 Technical data	
Pitch (间距):	3.81mm
Approval (认证):	
Rated voltage (电压):	300V 160V
Rated current (电流):	10A 17.5A
Wire range (线径):	26-16AWG 0.2-1.5mm ²
PCB hole Dia(PCB直径):	Φ 1.4mm
料号 Part Number	
极数 (Poles)	型号 (Model)
02	TLM-006A-3.81-02P
:	:
16	TLM-006A-3.81-16P

TLM-212V

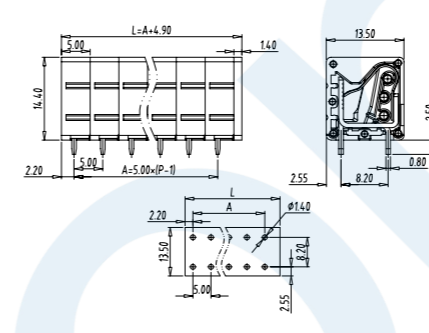
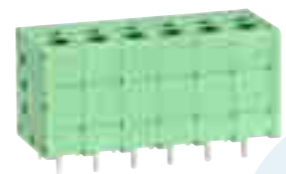

技术数据 Technical data	
Pitch (间距):	5.00mm
Approval (认证):	
Rated voltage (电压):	300V 320V
Rated current (电流):	20A 24A
Wire range (线径):	26-12AWG 0.2-2.5mm ² 4.0mm ² sol
料号 Part Number	
极数 (Poles)	型号 (Model)
01	TLM-212V-01P
:	:
24	TLM-212V-24P

TLM-212R

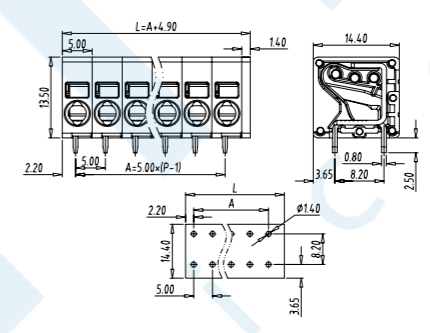

技术数据 Technical data	
Pitch (间距):	5.00mm
Approval (认证):	
Rated voltage (电压):	300V 320V
Rated current (电流):	20A 24A
Wire range (线径):	26-12AWG 0.2-2.5mm ² 4.0mm ² sol
料号 Part Number	
极数 (Poles)	型号 (Model)
01	TLM-212R-01P
:	:
24	TLM-212R-24P

TLM-212V-A175

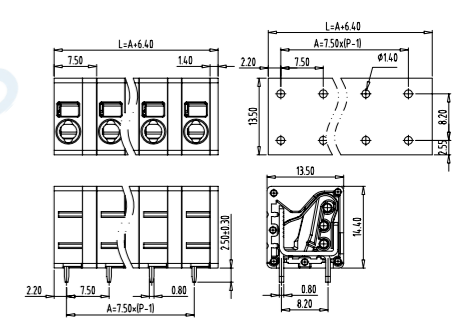
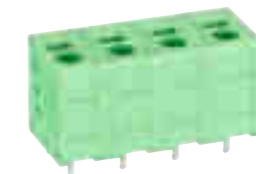

技术数据 Technical data	
Pitch (间距):	10.00mm
Approval (认证):	
Rated voltage (电压):	300V 320V
Rated current (电流):	20A 24A
Wire range (线径):	26-12AWG 0.2-2.5mm ² 4.0mm ² sol
PCB hole Dia(PCB直径):	Φ 1.4mm
料号 Part Number	
极数 (Poles)	型号 (Model)
02	TLM-212V-A175-02P
:	:
12	TLM-212V-A175-12P

TLM-006A-5.08

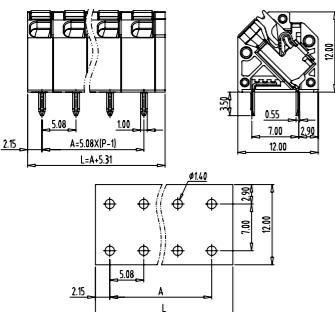
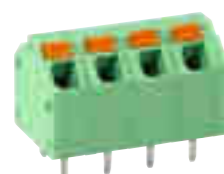

技术数据 Technical data	
Pitch (间距):	5.08mm
Approval (认证):	
Rated voltage (电压):	300V 320V
Rated current (电流):	10A 17.5A
Wire range (线径):	26-16AWG 0.2-1.5mm ²
PCB hole Dia(PCB直径):	Φ 1.4mm
料号 Part Number	
极数 (Poles)	型号 (Model)
02	TLM-006A-5.08-02P
:	:
16	TLM-006A-5.08-16P

TLM-012V

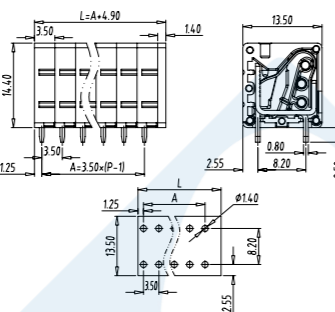
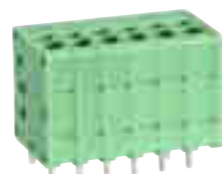

技术数据 Technical data	
Pitch (间距):	3.50mm
Approval (认证):	
Rated voltage (电压):	300V 160V
Rated current (电流):	10A 17.5A
Wire range (线径):	26-16AWG 0.2-1.5mm ²
料号 Part Number	
极数 (Poles)	型号 (Model)
01	TLM-012V-01P
:	:
24	TLM-012V-24P

TLM-012R

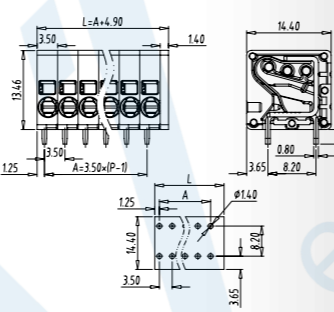

技术数据 Technical data	
Pitch (间距):	3.50mm
Approval (认证):	
Rated voltage (电压):	300V 160V
Rated current (电流):	10A 17.5A
Wire range (线径):	26-16AWG 0.2-1.5mm ²
料号 Part Number	
极数 (Poles)	型号 (Model)
01	TLM-012R-01P
:	:
24	TLM-012R-24P

TLM-212R-A175

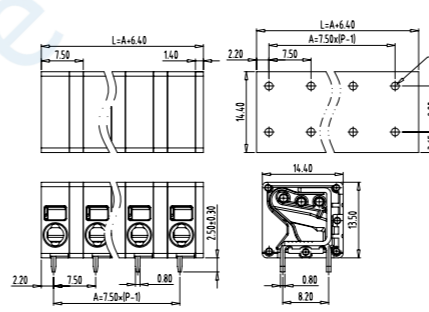

技术数据 Technical data	
Pitch (间距):	10.00mm
Approval (认证):	
Rated voltage (电压):	300V 320V
Rated current (电流):	20A 24A
Wire range (线径):	26-12AWG 0.2-2.5mm ² 4.0mm ² sol
PCB hole Dia(PCB直径):	Φ 1.4mm
料号 Part Number	
极数 (Poles)	型号 (Model)
02	TLM-212R-A175-02P
:	:
12	TLM-212R-A175-12P

TLM-212V-9999

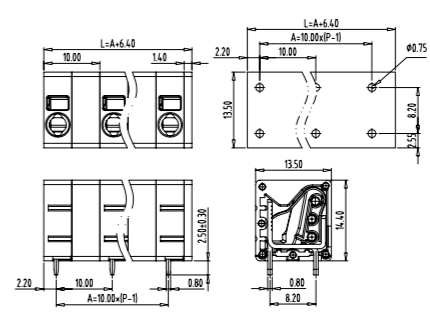
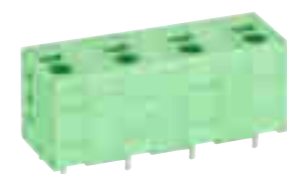

技术数据 Technical data	
Pitch (间距):	10.00mm
Approval (认证):	
Rated voltage (电压):	300V 320V
Rated current (电流):	20A 24A
Wire range (线径):	26-12AWG 0.2-2.5mm ² 4.0mm ² sol
PCB hole Dia(PCB直径):	Φ 1.4mm
料号 Part Number	
极数 (Poles)	型号 (Model)
02	TLM-212V-9999-02P
:	:
12	TLM-212V-9999-12P

TLM-212R-9999

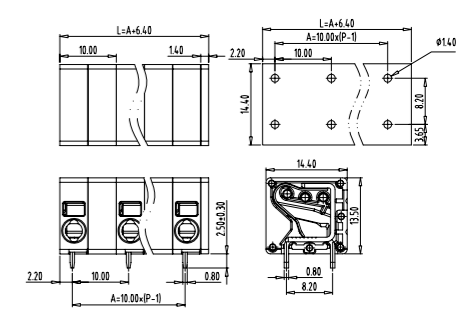

技术数据 Technical data	
Pitch (间距):	10.00mm
Approval (认证):	
Rated voltage (电压):	300V 320V
Rated current (电流):	20A 24A
Wire range (线径):	26-12AWG 0.2-2.5mm ² 4.0mm ² sol
PCB hole Dia(PCB直径):	Φ 1.4mm
料号 Part Number	
极数 (Poles)	型号 (Model)
02	TLM-212R-9999-02P
:	:
12	TLM-212R-9999-12P

TLM-405AA

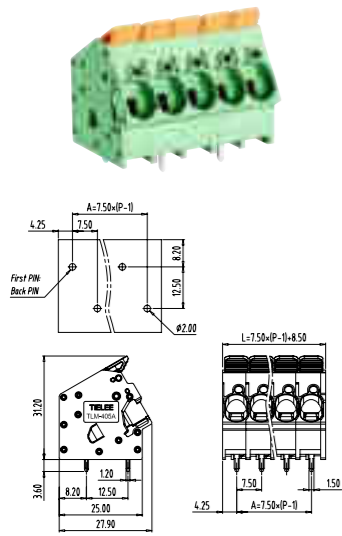

TLM-405AB

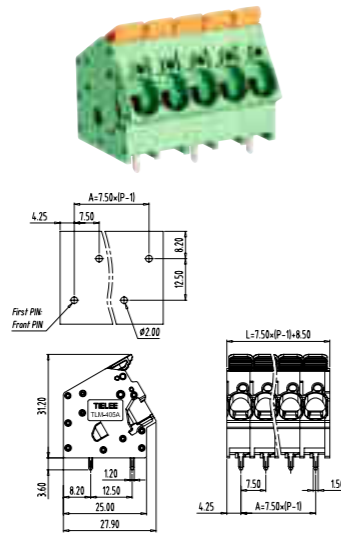

TLM-705A

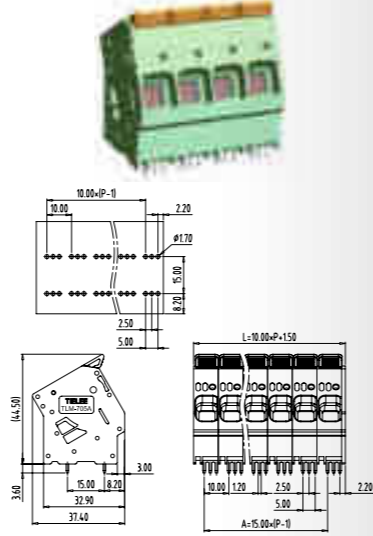

技术数据 Technical data	
Pitch (间距):	7.50mm
Approval (认证):	UL, VDE
Rated voltage (电压):	600V 1000V
Rated current (电流):	38A 41A
Wire range (线径):	24-8AWG 0.2-6mm ² 10mm ² str
PCB hole Dia(PCB直径):	Φ2.00mm
料号 Part Number	
极数 (Poles)	型号 (Model)
02	TLM-405AA-02P
:	:
12	TLM-405AA-12P

技术数据 Technical data	
Pitch (间距):	7.50mm
Approval (认证):	UL, VDE
Rated voltage (电压):	600V 1000V
Rated current (电流):	38A 41A
Wire range (线径):	24-8AWG 0.2-6mm ² 10mm ² str
PCB hole Dia(PCB直径):	Φ2.00mm
料号 Part Number	
极数 (Poles)	型号 (Model)
02	TLM-405AB-02P
:	:
12	TLM-405AB-12P

技术数据 Technical data	
Pitch (间距):	10.00mm
Approval (认证):	UL(Applying) VDE(Applying)
Rated voltage (电压):	600V(01P) 300V(≥02P) 1000V(01P) 400V(≥02P)
Rated current (电流):	72A 76A
Wire range (线径):	18-4AWG 0.75-25mm ²
PCB hole Dia(PCB直径):	Φ1.70mm
料号 Part Number	
极数 (Poles)	型号 (Model)
01	TLM-705A-01P
:	:
12	TLM-705A-12P

TLM-705AA-15.00

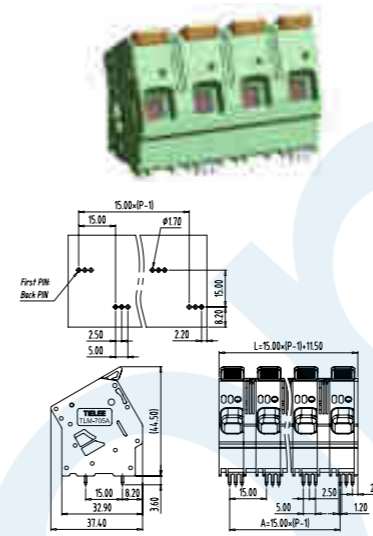

TLM-705AB-15.00

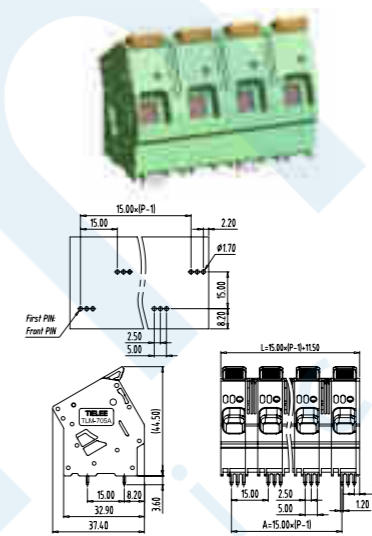

TLM-250C(TLM-250C-9999)

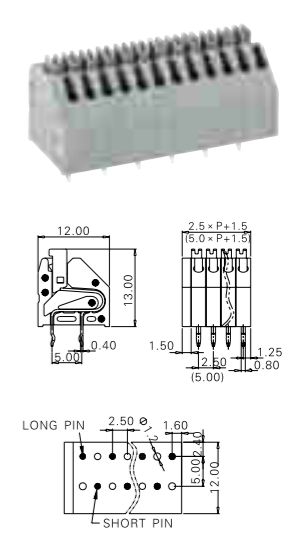

技术数据 Technical data	
Pitch (间距):	15.00mm
Approval (认证):	UL(Applying) VDE(Applying)
Rated voltage (电压):	1000V 1000V
Rated current (电流):	66A 76A
Wire range (线径):	18-4AWG 0.75-25mm ²
PCB hole Dia(PCB直径):	Φ1.70mm
料号 Part Number	
极数 (Poles)	型号 (Model)
02	TLM-705AA-15.00-02P
:	:
12	TLM-705AA-15.00-12P

技术数据 Technical data	
Pitch (间距):	15.00mm
Approval (认证):	UL(Applying) VDE(Applying)
Rated voltage (电压):	1000V 1000V
Rated current (电流):	66A 76A
Wire range (线径):	18-4AWG 0.75-25mm ²
PCB hole Dia(PCB直径):	Φ1.70mm
料号 Part Number	
极数 (Poles)	型号 (Model)
02	TLM-705AB-15.00-02P
:	:
12	TLM-705AB-15.00-12P

技术数据 Technical data	
Pitch (间距):	2.5mm(5.00mm)
Approval (认证):	UL, VDE
Rated voltage (电压):	250V 250V
Rated current (电流):	2A 2A
Wire range (线径):	20AWG 0.2-0.5mm ²
PCB hole Dia(PCB直径):	Φ1.2mm
料号 Part Number	
极数 (Poles)	型号 (Model)
02	TLM-250C-02P(TLM-250C-9999-02P)
:	:
24	TLM-250C-24P(TLM-250C-9999-24P)

TLM-705AA

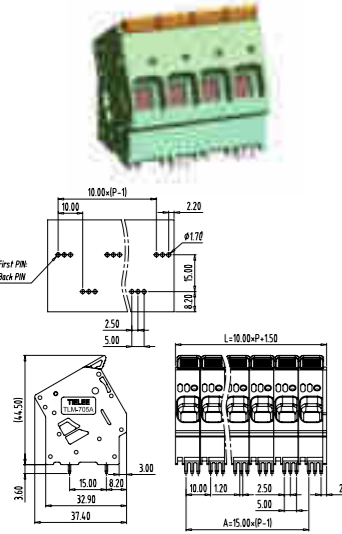

TLM-705AB

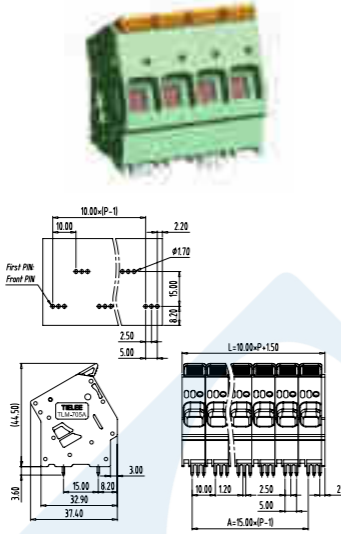

TLM-705A-15.00

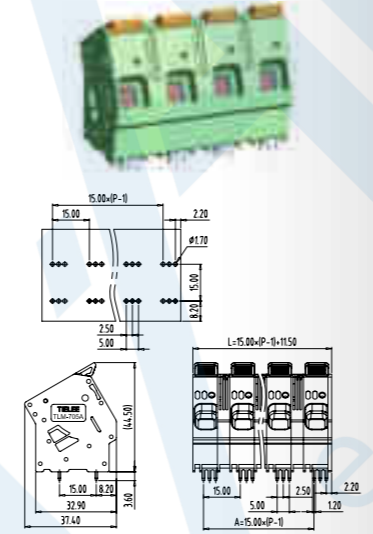

技术数据 Technical data	
Pitch (间距):	10.00mm
Approval (认证):	UL(Applying) VDE(Applying)
Rated voltage (电压):	600V 1000V
Rated current (电流):	66A 76A
Wire range (线径):	18-4AWG 0.75-25mm ²
PCB hole Dia(PCB直径):	Φ1.70mm
料号 Part Number	
极数 (Poles)	型号 (Model)
02	TLM-705AA-02P
:	:
12	TLM-705AA-12P

技术数据 Technical data	
Pitch (间距):	10.00mm
Approval (认证):	UL(Applying) VDE(Applying)
Rated voltage (电压):	600V 1000V
Rated current (电流):	66A 76A
Wire range (线径):	18-4AWG 0.75-25mm ²
PCB hole Dia(PCB直径):	Φ1.70mm
料号 Part Number	
极数 (Poles)	型号 (Model)
02	TLM-705AB-02P
:	:
12	TLM-705AB-12P

技术数据 Technical data	
Pitch (间距):	15.00mm
Approval (认证):	UL(Applying) VDE(Applying)
Rated voltage (电压):	300V 1000V
Rated current (电流):	72A 76A
Wire range (线径):	18-4AWG 0.75-25mm ²
PCB hole Dia(PCB直径):	Φ1.70mm
料号 Part Number	
极数 (Poles)	型号 (Model)
02	TLM-705A-15.00-02P
:	:
12	TLM-705A-15.00-12P

TLM-250D(TLM-250D-9999)

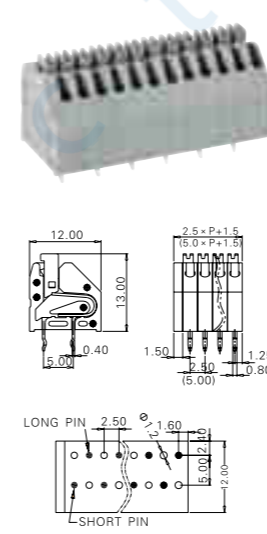

TLM-002C(TLM-002C-9999)

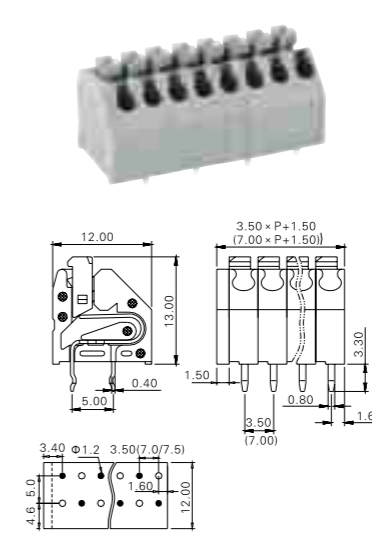

TLM-002D(TLM-002D-9999)

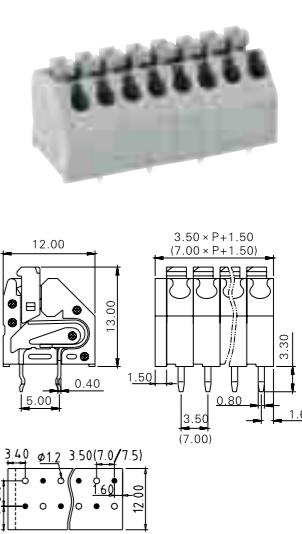

技术数据 Technical data	
Pitch (间距):	2.5mm(5.00mm)
Approval (认证):	UL, VDE
Rated voltage (电压):	250V 250V
Rated current (电流):	2A 2A
Wire range (线径):	20AWG 0.2-0.5mm ²
PCB hole Dia(PCB直径):	Φ1.2mm
料号 Part Number	
极数 (Poles)	型号 (Model)
02	TLM-250D-02P(TLM-250D-9999-02P)
:	:
24	TLM-250D-24P(TLM-250D-9999-24P)

技术数据 Technical data	
Pitch (间距):	3.50mm(7.0mm)
Approval (认证):	UL, VDE
Rated voltage (电压):	300V 250V
Rated current (电流):	8A 2A
Wire range (线径):	28-16AWG 14AWG sol 0.5-0.75mm ²
PCB hole Dia(PCB直径):	Φ1.2mm
料号 Part Number	
极数 (Poles)	型号 (Model)
02	TLM-002C-02P(TLM-002C-9999-02P)
:	:
24	TLM-002C-24P(TLM-002C-9999-24P)

技术数据 Technical data	
Pitch (间距):	3.50mm(7.0mm)
Approval (认证):	UL, VDE
Rated voltage (电压):	300V 250V
Rated current (电流):	8A 2A
Wire range (线径):	28-16AWG 14AWG sol 0.5-0.75mm ²
PCB hole Dia(PCB直径):	Φ1.2mm
料号 Part Number	
极数 (Poles)	型号 (Model)
02	TLM-002D-02P(TLM-002D-9999-02P)
:	:
24	TLM-002D-24P(TLM-002D-9999-24P)

TLM-900V

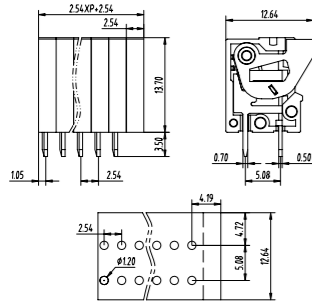
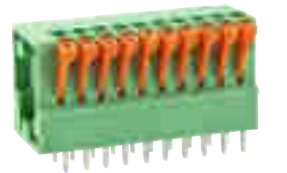

技术数据 Technical data	
Pitch (间距):	2.54mm
Approval (认证):	UL
Rated voltage (电压):	150V
Rated current (电流):	2A
Wire range (线径):	26-20AWG
PCB hole Dia(PCB 直径):	Φ 1.2mm
料号 Part Number	
极数 (Poles)	型号 (Model)
02	TLM-900V-02P
:	:
24	TLM-900V-24P

TLM-900R

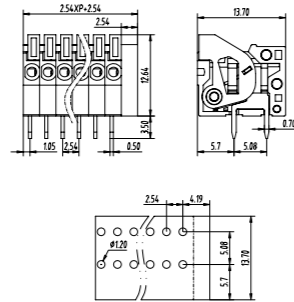
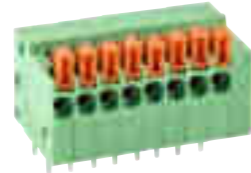

技术数据 Technical data	
Pitch (间距):	2.54mm
Approval (认证):	UL
Rated voltage (电压):	150V
Rated current (电流):	2A
Wire range (线径):	26-20AWG
PCB hole Dia(PCB 直径):	Φ 1.2mm
料号 Part Number	
极数 (Poles)	型号 (Model)
02	TLM-900R-02P
:	:
24	TLM-900R-24P

TLM-200V(TLM-300V)

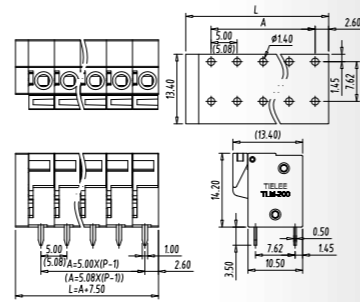
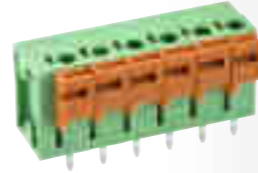

技术数据 Technical data	
Pitch (间距):	5.00mm(5.08mm)
Approval (认证):	UL
Rated voltage (电压):	300V 320V
Rated current (电流):	10A 17.5A
Wire range (线径):	22-14AWG 0.2-1.5mm ²
PCB hole Dia(PCB 直径):	Φ 1.4mm
料号 Part Number	
极数 (Poles)	型号 (Model)
02	TLM-200V-02P(TLM-300V-02P)
:	:
24	TLM-200V-24P(TLM-300V-24P)

TLM-210A(TLM-210A-9999)

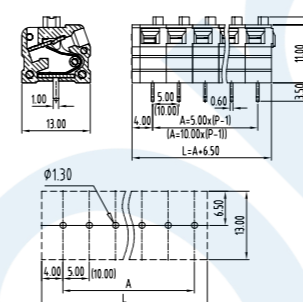

技术数据 Technical data	
Pitch (间距):	5.00mm(10.00mm)
Approval (认证):	UL(Applying)
Rated voltage (电压):	300V
Rated current (电流):	10A
Wire range (线径):	22-14AWG
PCB hole Dia(PCB 直径):	Φ 1.3mm
料号 Part Number	
极数 (Poles)	型号 (Model)
02(02)	TLM-210A-02P(TLM-210A-9999-02P)
:	:
20(12)	TLM-210A-20P(TLM-210A-9999-12P)

TLM-210B(TLM-210B-9999)

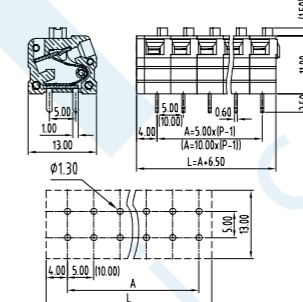

技术数据 Technical data	
Pitch (间距):	5.00mm(10.00mm)
Approval (认证):	UL(Applying)
Rated voltage (电压):	300V
Rated current (电流):	10A
Wire range (线径):	22-14AWG
PCB hole Dia(PCB 直径):	Φ 1.3mm
料号 Part Number	
极数 (Poles)	型号 (Model)
02(02)	TLM-210B-02P(TLM-210B-9999-02P)
:	:
20(12)	TLM-210B-20P(TLM-210B-9999-12P)

TLM-207

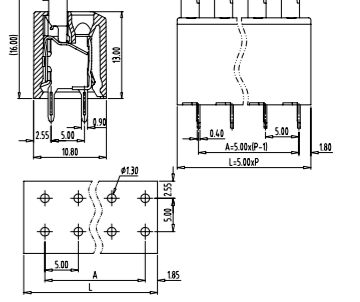

技术数据 Technical data	
Pitch (间距):	5.00mm
Approval (认证):	UL VDE(Applying)
Rated voltage (电压):	300V 320V
Rated current (电流):	10A 17.5A
Wire range (线径):	20-16AWG 0.5-1.5mm ²
PCB hole Dia(PCB 直径):	Φ 1.3mm
料号 Part Number	
极数 (Poles)	型号 (Model)
02	TLM207-02P
:	:
24	TLM207-24P

TLM-300R

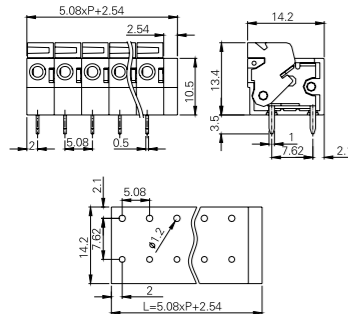
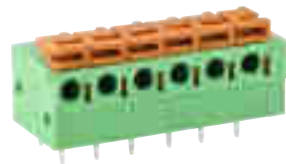

技术数据 Technical data	
Pitch (间距):	5.08mm
Approval (认证):	UL
Rated voltage (电压):	300V 320V
Rated current (电流):	10A 17.5A
Wire range (线径):	22-14AWG 0.2-1.5mm ²
PCB hole Dia(PCB 直径):	Φ 1.2mm
料号 Part Number	
极数 (Poles)	型号 (Model)
02	TLM-300R-02P
:	:
24	TLM-300R-24P

TLM-003

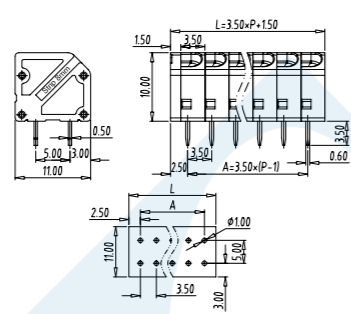

技术数据 Technical data	
Pitch (间距):	3.50mm
Approval (认证):	UL VDE(Applying)
Rated voltage (电压):	300V 160V
Rated current (电流):	10A 15A
Wire range (线径):	26-16AWG 0.34-1.5mm ²
料号 Part Number	
极数 (Poles)	型号 (Model)
02	TLM-003-02P
:	:
24	TLM-003-24P

TLM-211

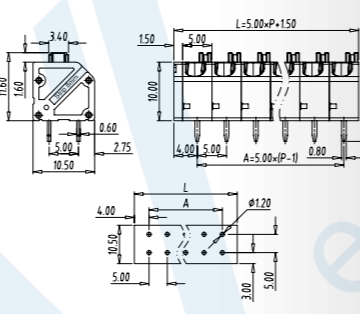

技术数据 Technical data	
Pitch (间距):	5.00mm
Approval (认证):	UL VDE(Applying)
Rated voltage (电压):	300V 320V
Rated current (电流):	13.5A 17.5A
Wire range (线径):	26-14AWG 0.34-1.5mm ²
料号 Part Number	
极数 (Poles)	型号 (Model)
02	TLM-211-02P
:	:
24	TLM-211-24P

TLM-214R

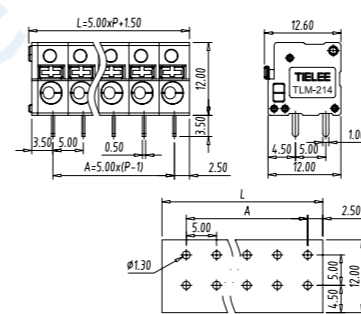

技术数据 Technical data	
Pitch (间距):	5.00mm
Approval (认证):	UL VDE(Applying)
Rated voltage (电压):	300V 320V
Rated current (电流):	8A 17.5A
Wire range (线径):	26-14AWG 0.2-1.5mm ²
PCB hole Dia(PCB 直径):	Φ 1.3mm
料号 Part Number	
极数 (Poles)	型号 (Model)
02	TLM-214R-02P
:	:
24	TLM-214R-24P

TLM-201R(TLM-301R)

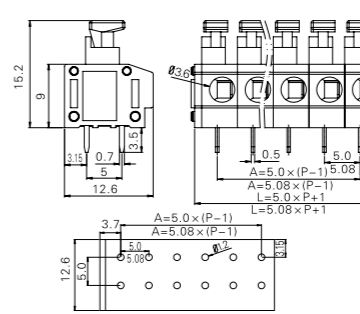
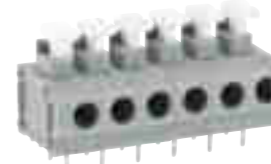

技术数据 Technical data	
Pitch (间距):	5.00mm(5.08mm)
Approval (认证):	UL
Rated voltage (电压):	300V 320V
Rated current (电流):	10A 24A
Wire range (线径):	20-14AWG 0.2-1.5mm ²
PCB hole Dia(PCB 直径):	Φ 1.2mm
料号 Part Number	
极数 (Poles)	型号 (Model)
02	TLM-201R-02P(TLM-301R-02P)
:	:
24	TLM-201R-24P(TLM-301R-24P)

TLM-202R(TLM-302R)

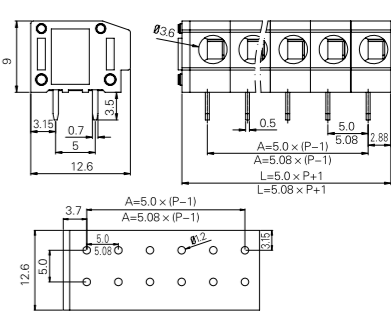
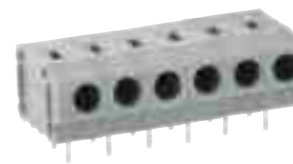

技术数据 Technical data	
Pitch (间距):	5.00mm(5.08mm)
Approval (认证):	UL
Rated voltage (电压):	300V 320V
Rated current (电流):	10A 24A
Wire range (线径):	20-14AWG 0.2-1.5mm ²
PCB hole Dia(PCB 直径):	Φ 1.2mm
料号 Part Number	
极数 (Poles)	型号 (Model)
02	TLM-202R-02P(TLM-302R-02P)
:	:
24	TLM-202R-24P(TLM-302R-24P)

TLM-203(TLM-303)(TLM-403)

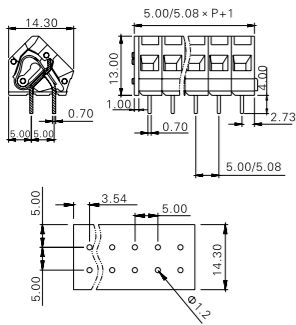
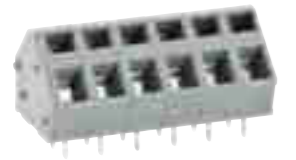

技术数据 Technical data	
Pitch (间距):	5.00mm(5.08mm)(7.50mm)
Approval (认证):	UL, CE, Ex
Rated voKage (电压):	300V 320V
Rated current (电流):	15A 16A
Wire range (线径):	28-12AWG 2.5mm ²
PCB hole Dia(PCB直径):	Φ1.2mm
料号 Part Number	
极数 (Poles)	型号 (Model)
02	TLM-203-02P(TLM-303-02P)(TLM-403-02P)
:	:
24	TLM-203-24P(TLM-303-24P)(TLM-403-24P)

TLM-203B-5.0

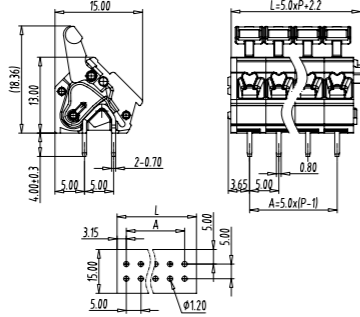
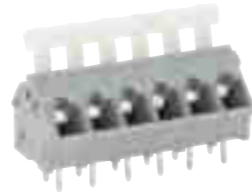

技术数据 Technical data	
Pitch (间距):	5.00mm
Approval (认证):	UL, CE, Ex
Rated voKage (电压):	300V 320V
Rated current (电流):	15A 16A
Wire range (线径):	28-12AWG 0.2-2.5mm ²
PCB hole Dia(PCB直径):	Φ1.2mm
料号 Part Number	
极数 (Poles)	型号 (Model)
02	TLM-203B-5.0-02P
:	:
24	TLM-203B-5.0-24P

TLM-203B-7.5

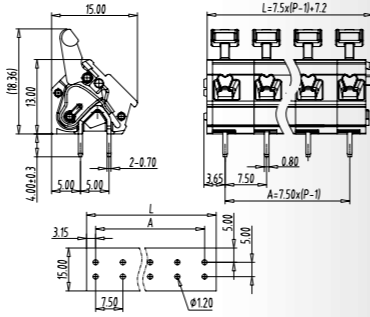

技术数据 Technical data	
Pitch (间距):	7.50mm
Approval (认证):	UL, CE, Ex
Rated voKage (电压):	300V 630V
Rated current (电流):	15A 16A
Wire range (线径):	28-12AWG 0.2-2.5mm ²
PCB hole Dia(PCB直径):	Φ1.2mm
料号 Part Number	
极数 (Poles)	型号 (Model)
02	TLM-203B-7.5-02P
:	:
24	TLM-203B-7.5-24P

TLM-213-10.0

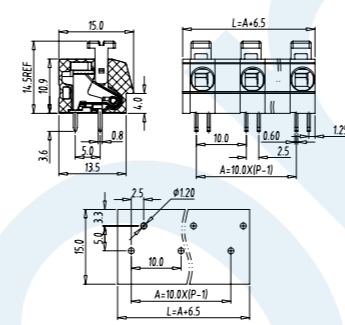

技术数据 Technical data	
Pitch (间距):	10.0mm
Approval (认证):	UL, CE, Ex
Rated voltage (电压):	300V 1000V
Rated current (电流):	16A 16A
Wire range (线径):	20-12AWG 0.2-2.5mm ²
料号 Part Number	
极数 (Poles)	型号 (Model)
02	TLM-213-10.0-02P
:	:
12	TLM-213-10.0-12P

TLM-304

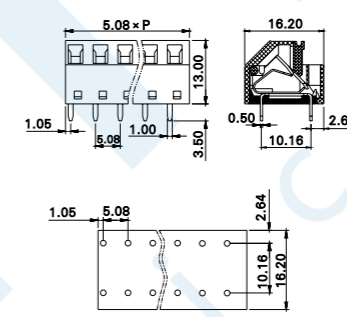

技术数据 Technical data	
Pitch (间距):	5.08mm
Approval (认证):	UL, CE, Ex
Rated voltage (电压):	300V
Rated current (电流):	15A
Wire range (线径):	24-14AWG
PCB hole Dia(PCB直径):	Φ1.2mm
料号 Part Number	
极数 (Poles)	型号 (Model)
02	TLM-304-02P
:	:
24	TLM-304-24P

TLM-203B-10.0

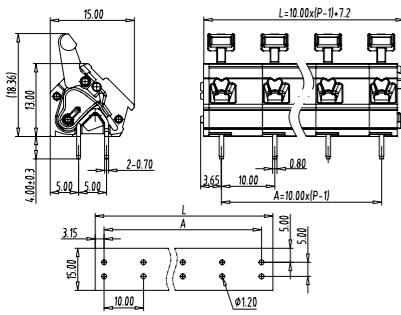
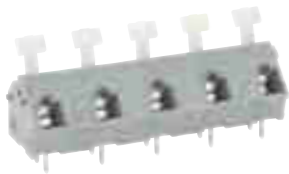

技术数据 Technical data	
Pitch (间距):	10.0mm
Approval (认证):	UL, CE, Ex
Rated voKage (电压):	300V 1000V
Rated current (电流):	15A 16A
Wire range (线径):	28-12AWG 0.2-2.5mm ²
PCB hole Dia(PCB直径):	Φ1.2mm
料号 Part Number	
极数 (Poles)	型号 (Model)
02	TLM-203B-10.0-02P
:	:
24	TLM-203B-10.0-24P

TLM-213

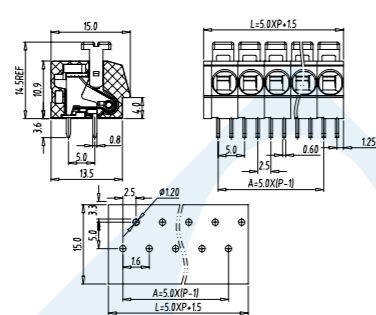

技术数据 Technical data	
Pitch (间距):	5.00mm
Approval (认证):	UL, CE, Ex
Rated voltage (电压):	300V 320V
Rated current (电流):	16A 16A
Wire range (线径):	20-12AWG 0.2-2.5mm ²
料号 Part Number	
极数 (Poles)	型号 (Model)
02	TLM-213-02P
:	:
24	TLM-213-24P

TLM-213-7.5

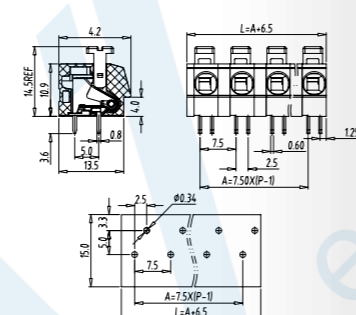

技术数据 Technical data	
Pitch (间距):	7.50mm
Approval (认证):	UL, CE, Ex
Rated voltage (电压):	300V 630V
Rated current (电流):	16A 16A
Wire range (线径):	20-12AWG 0.2-2.5mm ²
料号 Part Number	
极数 (Poles)	型号 (Model)
02	TLM-213-7.5-02P
:	:
16	TLM-213-7.5-16P

TLB SERIES – Terminal Strip

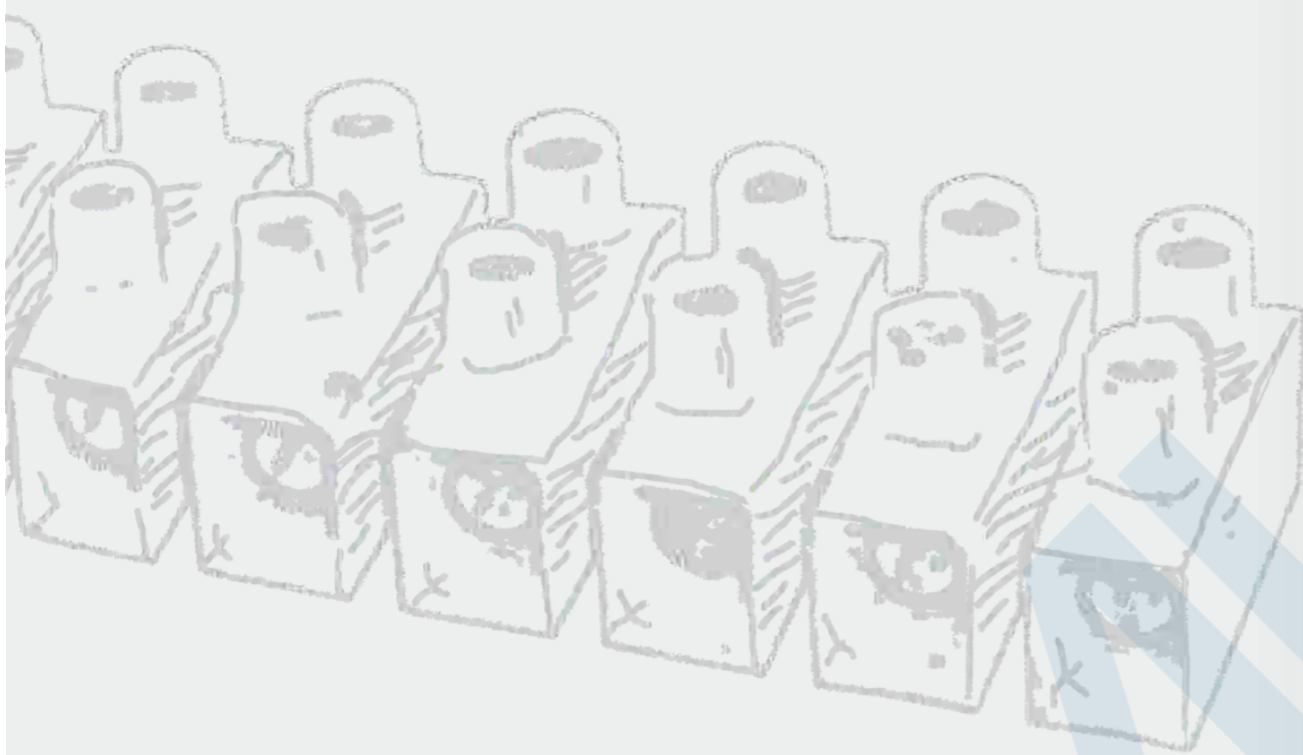

How to order

TLB-□□□(H)(W)-□-□□□□-□□P-□□

Screw: S=Slot screw, C=Cross screw

Color: T=Natural, W=White

Poles

Special code

A=High temperature material

H=High base, W=Wire protector

Series number

Pitch: 1=8.00, 2=10.00, 3=12.00, 4=13.50, 5=14.50, 6=16.50, 7=11.00, 8=14.00, 9=18.50

TLB-100(TLB-100H)

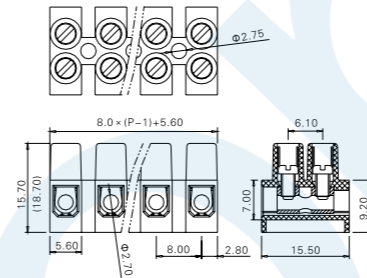

技术数据 Technical data	
Pitch (间距):	8.00mm
Approval (认证):	UL CE
Rated voltage (电压):	250V 450V
Rated current (电流):	20A 32A
Wire range (线径):	24-12AWG 1-4mm ²
Screw (螺丝):	M2.5
料号 Part Number	
极数 (Poles)	型号 (Model)
01	TLB-100-01P(TLB-100H-01P)
:	:
12	TLB-100-12P(TLB-100H-12P)

TLB-100W(TLB-100HW)

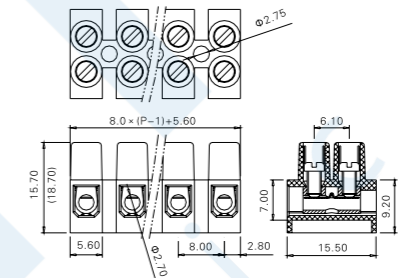
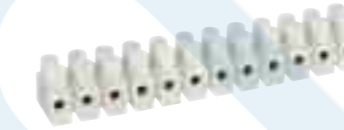

技术数据 Technical data	
Pitch (间距):	8.00mm
Approval (认证):	UL CE
Rated voltage (电压):	300V 450V
Rated current (电流):	20A 24A
Wire range (线径):	24-14AWG 12AWG sol 0.75-2.5mm ²
Screw (螺丝):	M2.5
料号 Part Number	
极数 (Poles)	型号 (Model)
01	TLB-100W-01P(TLB-100HW-01P)
:	:
12	TLB-100W-12P(TLB-100HW-12P)

TLB-200(TLB-200H)

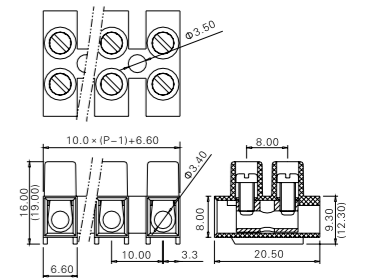

技术数据 Technical data	
Pitch (间距):	10.00mm
Approval (认证):	UL CE
Rated voltage (电压):	250V 450V
Rated current (电流):	30A 41A
Wire range (线径):	22-10AWG 2.5-6mm ²
Screw (螺丝):	M3
料号 Part Number	
极数 (Poles)	型号 (Model)
02	TLB-200-02P(TLB-200H-02P)
:	:
12	TLB-200-12P(TLB-200H-12P)

TLB-200W(TLB-200HW)

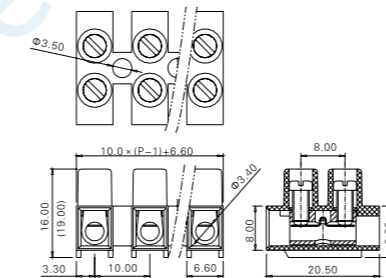

技术数据 Technical data	
Pitch (间距):	10.00mm
Approval (认证):	UL CE
Rated voltage (电压):	250V 450V
Rated current (电流):	30A 32A
Wire range (线径):	24-12AWG 10AWG sol 0.75-4mm ²
Screw (螺丝):	M3
料号 Part Number	
极数 (Poles)	型号 (Model)
02	TLB-200W-02P(TLB-200HW-02P)
:	:
12	TLB-200W-12P(TLB-200HW-12P)

TLB-300(TLB-300H)

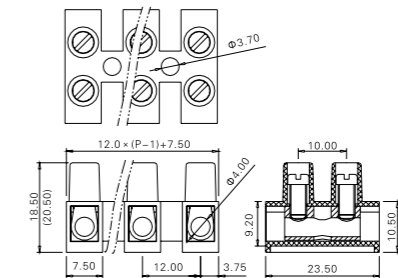

技术数据 Technical data	
Pitch (间距):	12.00mm
Approval (认证):	UL CE
Rated voltage (电压):	300V 750V
Rated current (电流):	30A 57A
Wire range (线径):	22-10AWG 4-6mm ² 10mm ² sol
Screw (螺丝):	M3.5
料号 Part Number	
极数 (Poles)	型号 (Model)
02	TLB-300-02P(TLB-300H-02P)
:	:
12	TLB-300-12P(TLB-300H-12P)

TLB-300W(TLB-300HW)

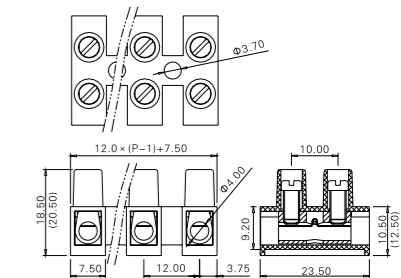

技术数据 Technical data	
Pitch (间距):	12.00mm
Approval (认证):	UL CE
Rated voltage (电压):	300V 750V
Rated current (电流):	30A 41A
Wire range (线径):	22-10AWG 1.5-6mm ²
Screw (螺丝):	M3.5
料号 Part Number	
极数 (Poles)	型号 (Model)
02	TLB-300W-02P(TLB-300HW-02P)
:	:
12	TLB-300W-12P(TLB-300HW-12P)

TLB-400

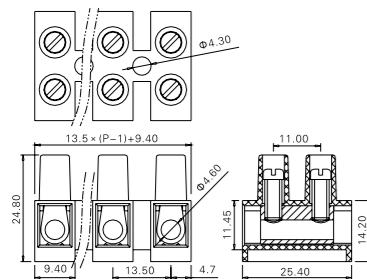
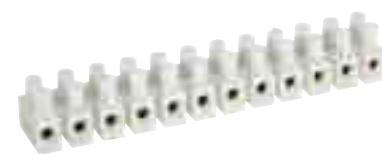

技术数据 Technical data	
Pitch (间距):	13.50mm
Approval (认证):	
Rated voltage (电压):	300V 750V
Rated current (电流):	50A 76A
Wire range (线径):	20-8AWG 6-10mm ² / 16mm ² Sol
Screw (螺丝):	M4
料号 Part Number	
极数 (Poles)	型号 (Model)
02	TLB-400-02P
:	:
12	TLB-400-12P

TLB-400W

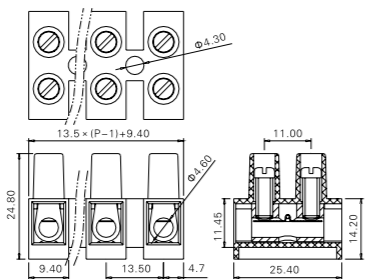

技术数据 Technical data	
Pitch (间距):	13.50mm
Approval (认证):	
Rated voltage (电压):	300V 750V
Rated current (电流):	50A 57A
Wire range (线径):	22-12AWG 10AWG Sol 2.5-10mm ²
Screw (螺丝):	M4
料号 Part Number	
极数 (Poles)	型号 (Model)
02	TLB-400W-02P
:	:
12	TLB-400W-12P

TLB-500

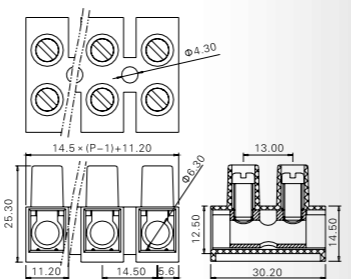

技术数据 Technical data	
Pitch (间距):	14.50mm
Approval (认证):	
Rated voltage (电压):	300V 750V
Rated current (电流):	65A 76A
Wire range (线径):	18-6AWG 6-16mm ²
Screw (螺丝):	M5
料号 Part Number	
极数 (Poles)	型号 (Model)
01	TLB-500-01P
:	:
12	TLB-500-12P

TLB-100-T(TLB-100H-T)

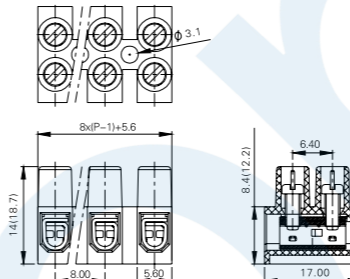

技术数据 Technical data	
Pitch (间距):	8.00mm
Approval (认证):	
Rated voltage (电压):	250V 450V
Rated current (电流):	20A 32A
Wire range (线径):	24-12AWG 1-4mm ²
Screw (螺丝):	
料号 Part Number	
极数 (Poles)	型号 (Model)
02	TLB-100-T-02P(TLB-100H-T-02P)
:	:
12	TLB-100-T-12P(TLB-100H-T-12P)

TLB-200-T(TLB-200H-T)

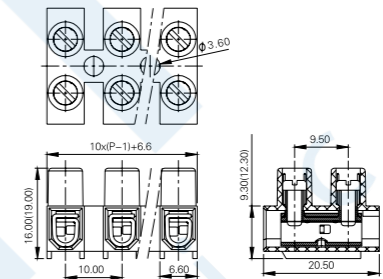

技术数据 Technical data	
Pitch (间距):	10.00mm
Approval (认证):	
Rated voltage (电压):	250V 450V
Rated current (电流):	30A 41A
Wire range (线径):	22-10AWG 2.5-6mm ²
Screw (螺丝):	
料号 Part Number	
极数 (Poles)	型号 (Model)
02	TLB-200-T-02P(TLB-200H-T-02P)
:	:
12	TLB-200-T-12P(TLB-200H-T-12P)

TLB-700-1P

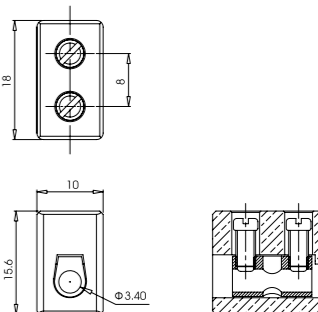

技术数据 Technical data	
Pitch (间距):	-
Approval (认证):	UL(Applying) VDE(Applying)
Rated voltage (电压):	300V 450V
Rated current (电流):	20A 32A
Wire range (线径):	22-12AWG 1.5-4.0mm ² Sol 6mm ²
Screw (螺丝):	M3.0
料号 Part Number	
极数 (Poles)	型号 (Model)
01	TLB-700-1P

TLB-500W

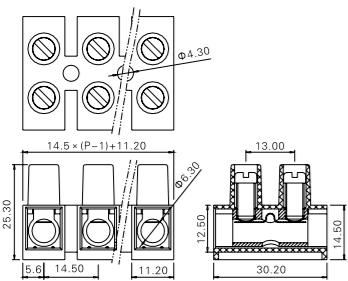

技术数据 Technical data	
Pitch (间距):	14.50mm
Approval (认证):	
Rated voltage (电压):	300V 750V
Rated current (电流):	65A 76A
Wire range (线径):	18-6AWG 4-16mm ²
Screw (螺丝):	M5
料号 Part Number	
极数 (Poles)	型号 (Model)
01	TLB-500W-01P
:	:
12	TLB-500W-12P

TLB-600

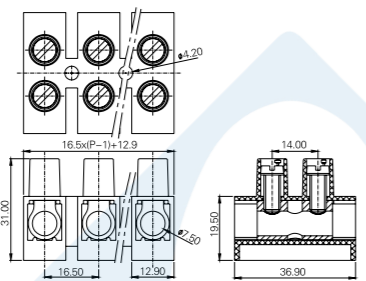
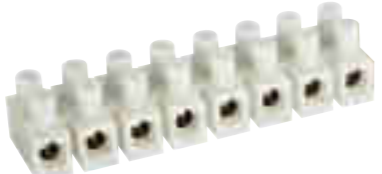

技术数据 Technical data	
Pitch (间距):	16.50mm
Approval (认证):	
Rated voltage (电压):	600V 750V
Rated current (电流):	85A 101A
Wire range (线径):	16-4AWG 4-25mm ²
Screw (螺丝):	M5
料号 Part Number	
极数 (Poles)	型号 (Model)
02	TLB-600-02P
:	:
12	TLB-600-12P

TLB-600W

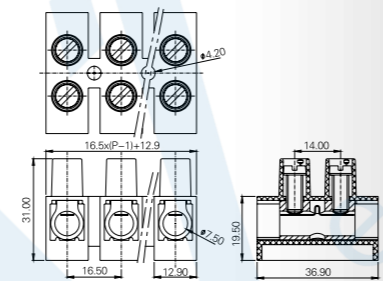

技术数据 Technical data	
Pitch (间距):	16.50mm
Approval (认证):	
Rated voltage (电压):	600V 750V
Rated current (电流):	85A 76A
Wire range (线径):	16-4AWG 4-25mm ²
Screw (螺丝):	M5
料号 Part Number	
极数 (Poles)	型号 (Model)
02	TLB-600W-02P
:	:
12	TLB-600W-12P

TLB-700-2P

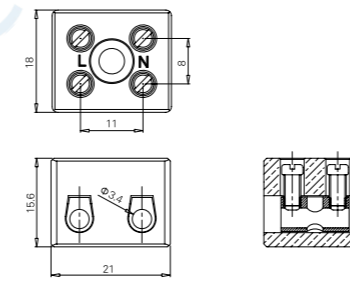

技术数据 Technical data	
Pitch (间距):	11.00mm
Approval (认证):	UL(Applying) VDE(Applying)
Rated voltage (电压):	300V 450V
Rated current (电流):	20A 32A
Wire range (线径):	22-12AWG 1.5-4.0mm ² / 6mm ² Sol
Screw (螺丝):	M3.0
料号 Part Number	
极数 (Poles)	型号 (Model)
02	TLB-700-2P

TLB-700-3P

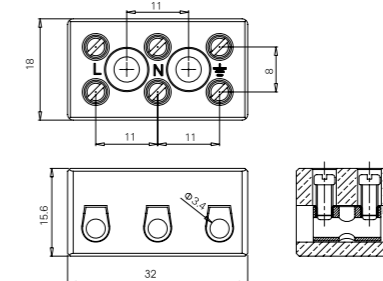

技术数据 Technical data	
Pitch (间距):	11.00mm
Approval (认证):	UL(Applying) VDE(Applying)
Rated voltage (电压):	300V 450V
Rated current (电流):	20A 32A
Wire range (线径):	22-12AWG 1.5-4.0mm ² / 6mm ² Sol
Screw (螺丝):	M3.0
料号 Part Number	
极数 (Poles)	型号 (Model)
03	TLB-700-3P

TLB-700-4P

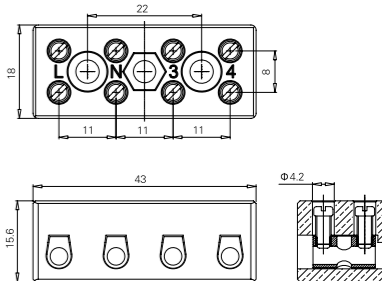

技术数据 Technical data	
Pitch (间距):	11.00mm
Approval (认证):	UL(Applying) VDE(Applying)
Rated voltage (电压):	300V 450V
Rated current (电流):	20A 32A
Wire range (线径):	22-12AWG 1.5-4.0mm ² / 6mm ² Sol
Screw (螺丝):	M3.0
料号 Part Number	
极数 (Poles)	型号 (Model)
04	TLB-700-4P

TLB-800-1P

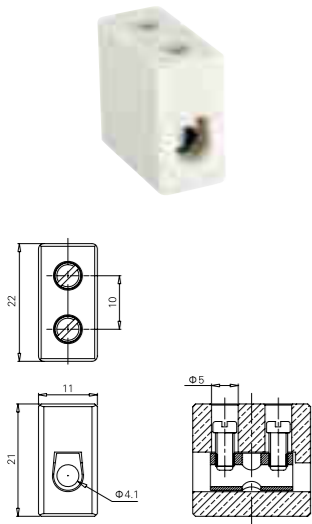

技术数据 Technical data	
Pitch (间距):	-
Approval (认证):	UL(Applying) VDE(Applying)
Rated voltage (电压):	300V 750V
Rated current (电流):	30A 41A
Wire range (线径):	22-10AWG 1.5-6.0mm ² 10mm ² Sol
Screw (螺丝):	M3.5
料号 Part Number	
极数 (Poles)	型号 (Model)
01	TLB-800-1P

TLB-800-2P

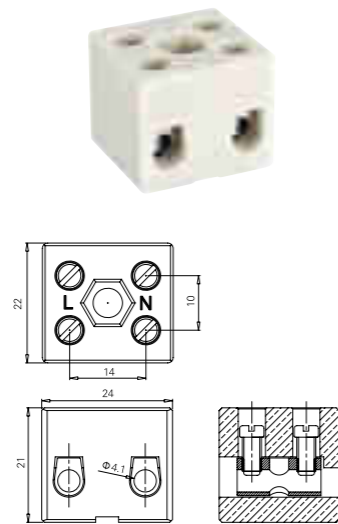

技术数据 Technical data	
Pitch (间距):	14.00mm
Approval (认证):	UL(Applying) VDE(Applying)
Rated voltage (电压):	300V 750V
Rated current (电流):	30A 41A
Wire range (线径):	22-10AWG 1.5-6.0mm ² 10mm ² Sol
Screw (螺丝):	M3.5
料号 Part Number	
极数 (Poles)	型号 (Model)
02	TLB-800-2P

TLB-800-3P

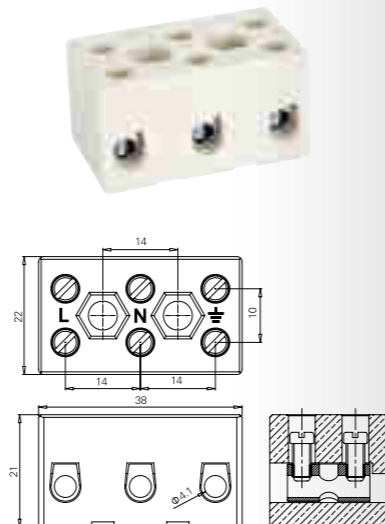

技术数据 Technical data	
Pitch (间距):	14.00mm
Approval (认证):	UL(Applying) VDE(Applying)
Rated voltage (电压):	300V 750V
Rated current (电流):	30A 41A
Wire range (线径):	22-10AWG 1.5-6.0mm ² 10mm ² Sol
Screw (螺丝):	M3.5
料号 Part Number	
极数 (Poles)	型号 (Model)
03	TLB-800-3P

TLB-800-4P

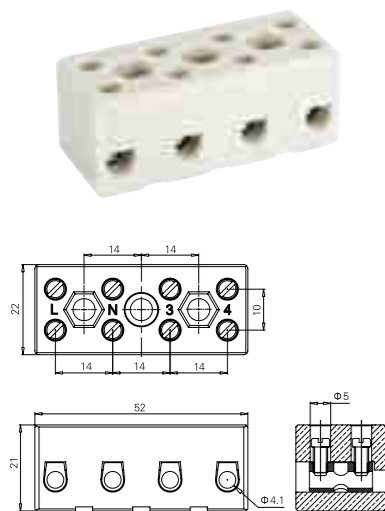

技术数据 Technical data	
Pitch (间距):	14.00mm
Approval (认证):	UL(Applying) VDE(Applying)
Rated voltage (电压):	300V 750V
Rated current (电流):	30A 41A
Wire range (线径):	22-10AWG 1.5-6.0mm ² 10mm ² Sol
Screw (螺丝):	M3.5
料号 Part Number	
极数 (Poles)	型号 (Model)
04	TLB-800-4P

TLB-900-2P

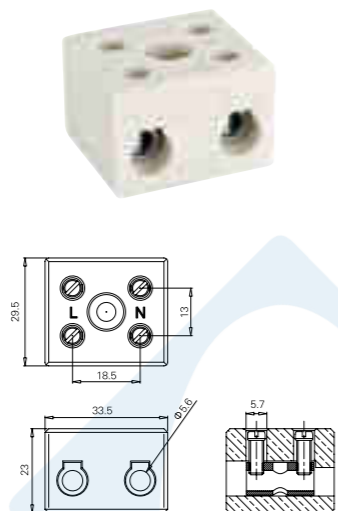

技术数据 Technical data	
Pitch (间距):	18.50mm
Approval (认证):	UL(Applying) VDE (Applying)
Rated voltage (电压):	600V 750V
Rated current (电流):	50A 57A
Wire range (线径):	18-8AWG 2.5-10mm ² 16mm ² Sol
Screw (螺丝):	M4.0
料号 Part Number	
极数 (Poles)	型号 (Model)
02	TLB-900-2P

TLB-900-3P

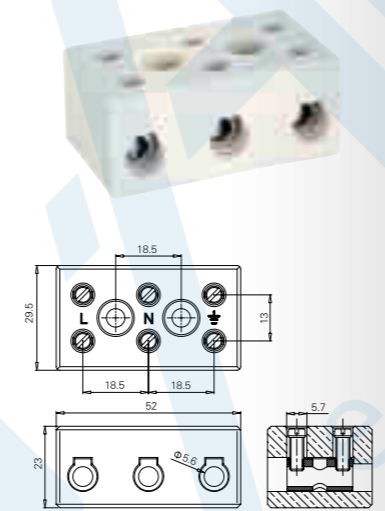

技术数据 Technical data	
Pitch (间距):	18.50mm
Approval (认证):	UL(Applying) VDE(Applying)
Rated voltage (电压):	600V 750V
Rated current (电流):	50A 57A
Wire range (线径):	18-8AWG 2.5-10mm ² 16mm ² Sol
Screw (螺丝):	M4.0
料号 Part Number	
极数 (Poles)	型号 (Model)
03	TLB-900-3P

TLB-01

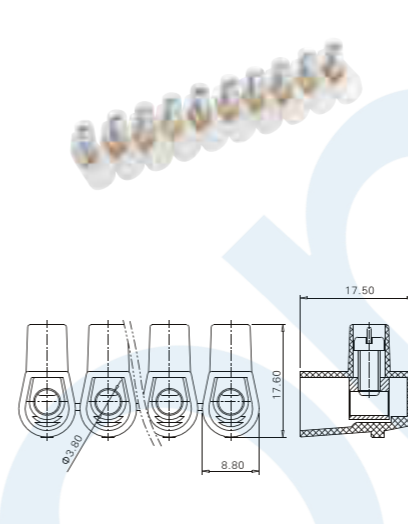

技术数据 Technical data	
Approval (认证):	VDE(Applying)
Rated voltage (电压):	450V
Rated current (电流):	24A
Wire range (线径):	2.5mm ²
Screw (螺丝):	M2
料号 Part Number	
极数 (Poles)	型号 (Model)
01	TLB-01-01P
:	:
10	TLB-01-10P

TLB-02

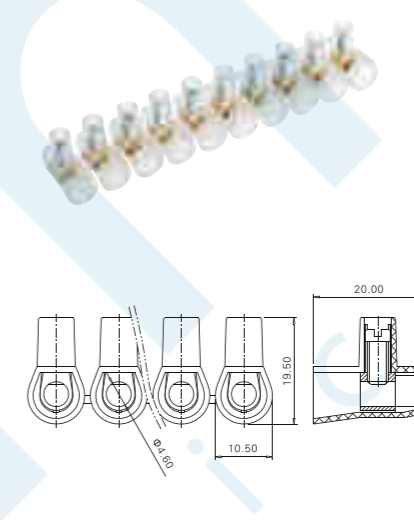

技术数据 Technical data	
Approval (认证):	VDE(Applying)
Rated voltage (电压):	450V
Rated current (电流):	32A
Wire range (线径):	4.0mm ²
Screw (螺丝):	M4
料号 Part Number	
极数 (Poles)	型号 (Model)
01	TLB-02-01P
:	:
10	TLB-02-10P

TLB-03

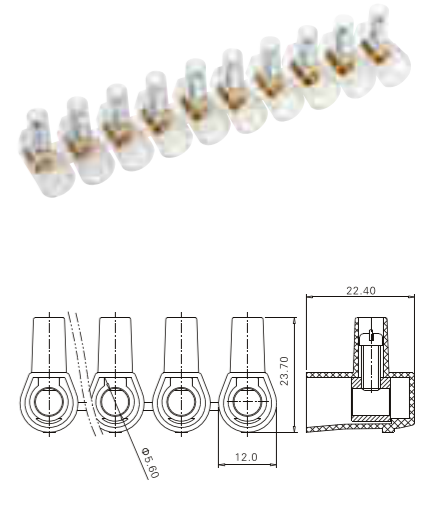

技术数据 Technical data	
Approval (认证):	VDE(Applying)
Rated voltage (电压):	450V
Rated current (电流):	41A
Wire range (线径):	6.0mm ²
Screw (螺丝):	M4
料号 Part Number	
极数 (Poles)	型号 (Model)
01	TLB-03-01P
:	:
10	TLB-03-10P

TLB-B001-02P

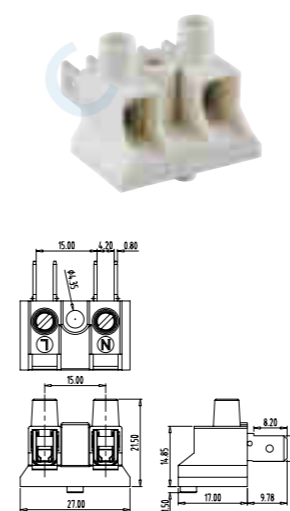

技术数据 Technical data	
Pitch (间距):	15.00mm
Approval (认证):	UL(Applying) VDE(Applying)
Rated voltage (电压):	300V 320V
Rated current (电流):	16A 16A
Wire range (线径):	22-12AWG 0.5-4mm ²
Screw (螺丝):	M3.5
料号 Part Number	
极数 (Poles)	型号 (Model)
02	TLB-B001-02P

TLB-B001-04P

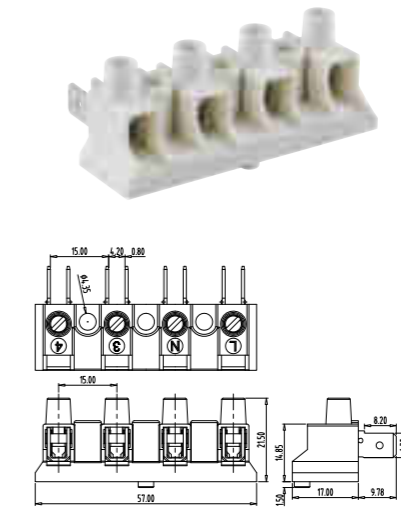

技术数据 Technical data	
Pitch (间距):	15.00mm
Approval (认证):	UL(Applying) VDE(Applying)
Rated voltage (电压):	300V 320V
Rated current (电流):	16A 16A
Wire range (线径):	22-12AWG 0.5-4mm ²
Screw (螺丝):	M3.5
料号 Part Number	
极数 (Poles)	型号 (Model)
04	TLB-B001-04P

TPK SERIES – Panel Feed – through Terminal Blocks

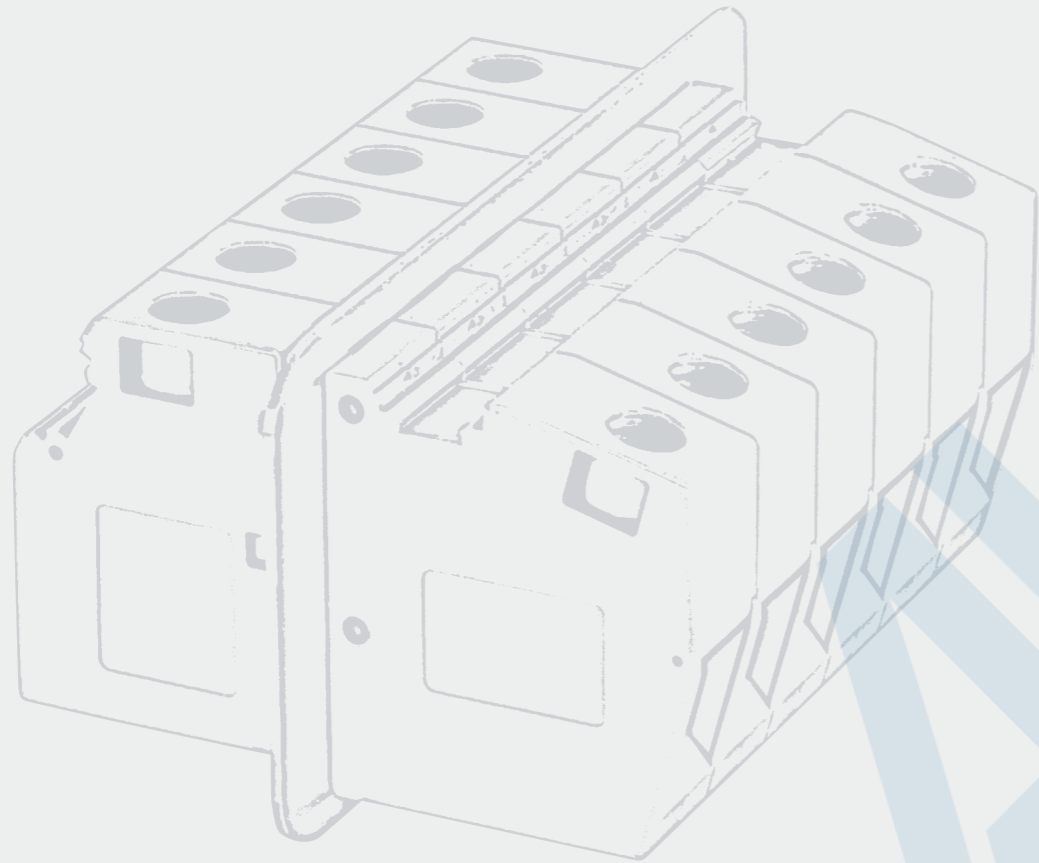

How to order

TPK □ □ □ □ - (VP) - □ □ □ □ - □ □

- Screw: S=Slot screw, C=Cross screw
- Color: G(G12)=Green, M=Gray
- Special code
- VP=Internal part with solder connection or screw connection
- Z=Splicing column, None=Without splicing column
- Max wire range: 4=4mm², 10=10mm², 16=16mm² ...
- V=Vertical, None=Horizontal

TPK 4

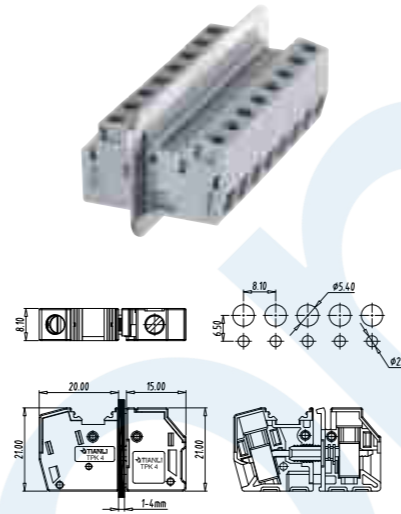

技术数据 Technical data	
Approval (认证):	UL VDE(Applying)
Rated voltage (电压):	300V 500V
Rated current (电流):	30A 32A 41A (6mm ² sol)
Wire range (线径):	30-10AWG 0.2-4mm ² sol / str 6mm ² sol
Screw (螺丝):	M3
料号 Part Number	
型号 (Model)	TPK 4

TPKV 4

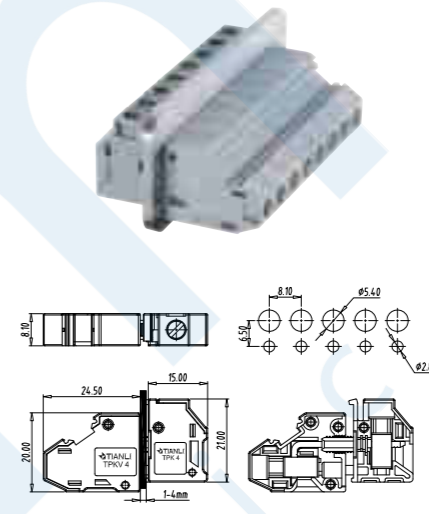

技术数据 Technical data	
Approval (认证):	UL VDE(Applying)
Rated voltage (电压):	300V 500V
Rated current (电流):	30A 32A 41A (6mm ² sol)
Wire range (线径):	30-10AWG 0.2-4mm ² sol / str 6mm ² sol
Screw (螺丝):	M3
料号 Part Number	
型号 (Model)	TPKV 4

TPK 10

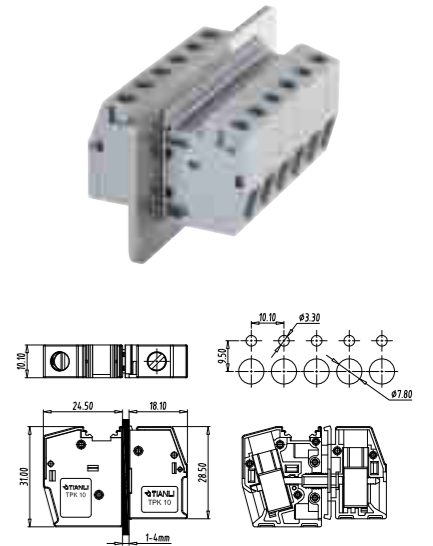

技术数据 Technical data	
Approval (认证):	UL VDE(Applying)
Rated voltage (电压):	300V 500V
Rated current (电流):	65A 57A 76A (16mm ² sol)
Wire range (线径):	20-6AWG 0.5-10mm ² sol / str 16mm ² sol
Screw (螺丝):	M4
料号 Part Number	
型号 (Model)	TPK 10

TPK 10-VP

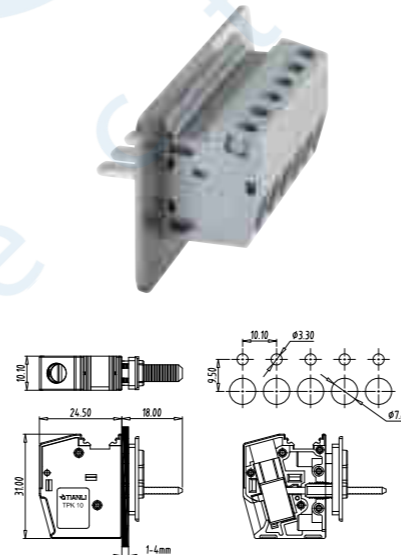

技术数据 Technical data	
Approval (认证):	UL VDE(Applying)
Rated voltage (电压):	300V 500V
Rated current (电流):	65A 57A 76A (16mm ² sol)
Wire range (线径):	20-6AWG 0.5-10mm ² sol / str 16mm ² sol
Screw (螺丝):	M4
料号 Part Number	
型号 (Model)	TPK 10-VP

TPKV 10

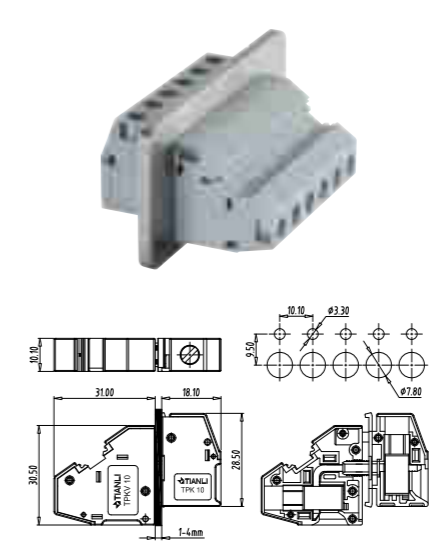

技术数据 Technical data	
Approval (认证):	UL VDE(Applying)
Rated voltage (电压):	300V 500V
Rated current (电流):	65A 57A 76A (16mm ² sol)
Wire range (线径):	20-6AWG 0.5-10mm ² sol / str 16mm ² sol
Screw (螺丝):	M4
料号 Part Number	
型号 (Model)	TPKV 10

TPKV 10-VP

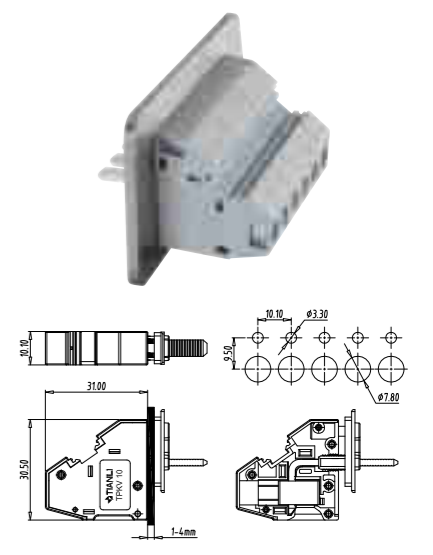

技术数据 Technical data	
Approval (认证):	UL VDE(Applying)
Rated voltage (电压):	300V 500V
Rated current (电流):	65A 57A 76A (16mm ² sol)
Wire range (线径):	20-6AWG 0.5-10mm ² sol / str 16mm ² sol
Screw (螺丝):	M4
料号 Part Number	
型号 (Model)	TPKV 10-VP

TPK 16

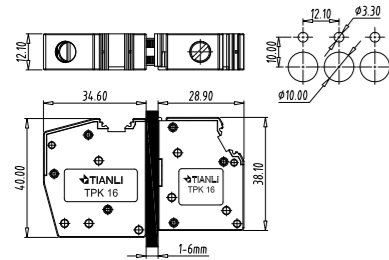

技术数据 Technical data	
Approval (认证):	UL VDE(Applying)
Rated voltage (电压):	600V 800V
Rated current (电流):	85A 76A 101A (25mm² sol)
Wire range (线径):	20-4AWG 0.5-16mm² sol / str 25mm² sol
Screw (螺丝):	M5
料号 Part Number	
型号 (Model)	TPK 16

TPK 16-VP

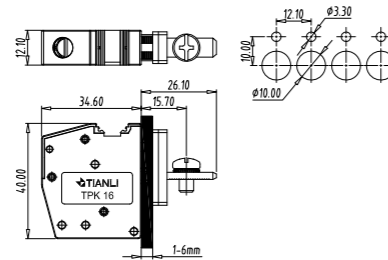

技术数据 Technical data	
Approval (认证):	UL VDE(Applying)
Rated voltage (电压):	600V 800V
Rated current (电流):	85A 76A 101A (25mm² sol)
Wire range (线径):	20-4AWG 0.5-16mm² sol / str 25mm² sol
Screw (螺丝):	M5
料号 Part Number	
型号 (Model)	TPK 16-VP

TPKV 16

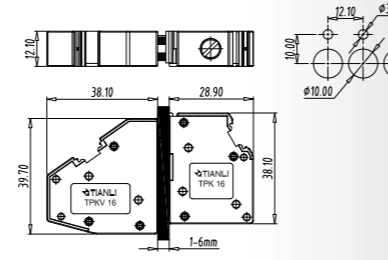

技术数据 Technical data	
Approval (认证):	UL VDE(Applying)
Rated voltage (电压):	600V 800V
Rated current (电流):	85A 76A 101A (25mm² sol)
Wire range (线径):	20-4AWG 0.5-16mm² sol / str 25mm² sol
Screw (螺丝):	M5
料号 Part Number	
型号 (Model)	TPKV 16

TPKV 25

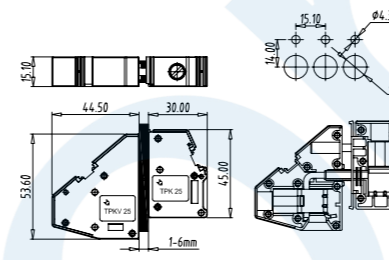

技术数据 Technical data	
Approval (认证):	UL VDE(Applying)
Rated voltage (电压):	600V 800V
Rated current (电流):	115A 76A 101A (25mm² sol)
Wire range (线径):	10-2AWG 6-25mm² sol / str 35mm² sol
Screw (螺丝):	M5
料号 Part Number	
型号 (Model)	TPKV 25

TPKV 25-VP

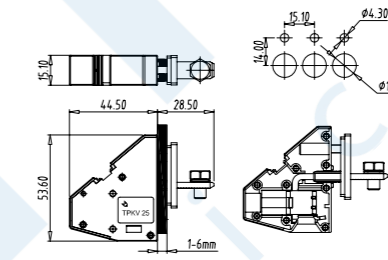
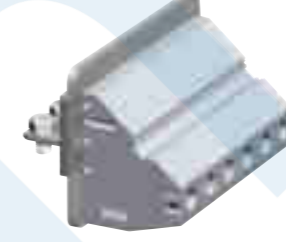

技术数据 Technical data	
Approval (认证):	UL VDE(Applying)
Rated voltage (电压):	600V 800V
Rated current (电流):	115A 76A 101A (25mm² sol)
Wire range (线径):	10-2AWG 6-25mm² sol / str 35mm² sol
Screw (螺丝):	M5
料号 Part Number	
型号 (Model)	TPKV 25-VP

TPKV 16-VP

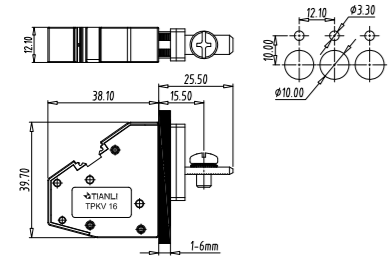

技术数据 Technical data	
Approval (认证):	UL VDE(Applying)
Rated voltage (电压):	600V 800V
Rated current (电流):	85A 76A 101A (25mm² sol)
Wire range (线径):	20-4AWG 0.5-16mm² sol / str 25mm² sol
Screw (螺丝):	M5
料号 Part Number	
型号 (Model)	TPKV 16-VP

TPK 25

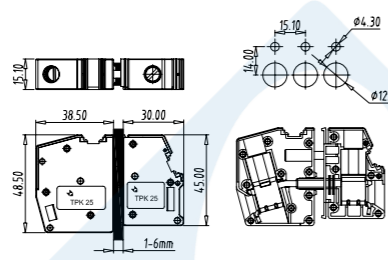

技术数据 Technical data	
Approval (认证):	UL VDE(Applying)
Rated voltage (电压):	600V 800V
Rated current (电流):	115A 76A 101A (25mm² sol)
Wire range (线径):	10-2AWG 6-25mm² sol / str 35mm² sol
Screw (螺丝):	M5
料号 Part Number	
型号 (Model)	TPK 25

TPK 25-VP

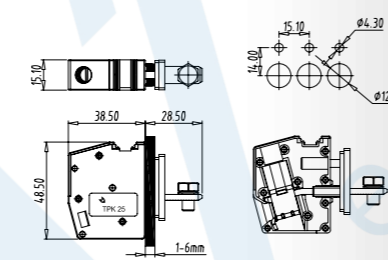
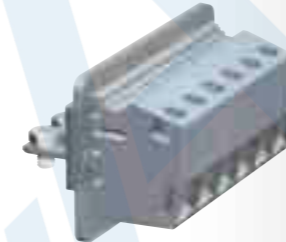

技术数据 Technical data	
Approval (认证):	UL VDE(Applying)
Rated voltage (电压):	600V 800V
Rated current (电流):	115A 76A 101A (25mm² sol)
Wire range (线径):	10-2AWG 6-25mm² sol / str 35mm² sol
Screw (螺丝):	M5
料号 Part Number	
型号 (Model)	TPK 25-VP

TLF SERIES – Fuse Terminal Block

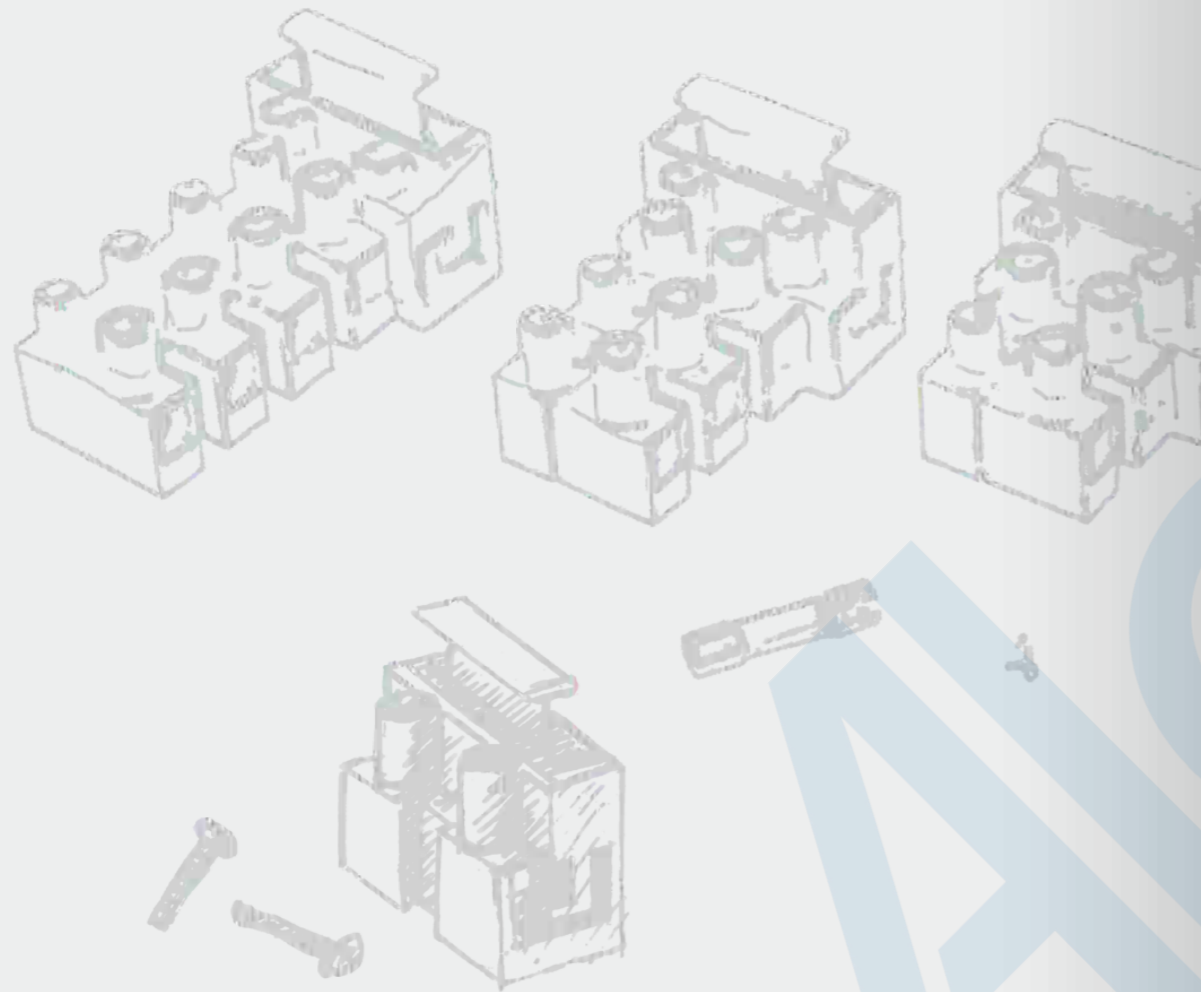

How to order

TLF □□□ E/SW - □□ P- □□

- Screw: S=Slot screw, C=Cross screw
- Color: M=Gray...
- Poles
- E=Earth screw thread, S=Earth screw, W=Wire protector
- Series number

TLF-100-01P

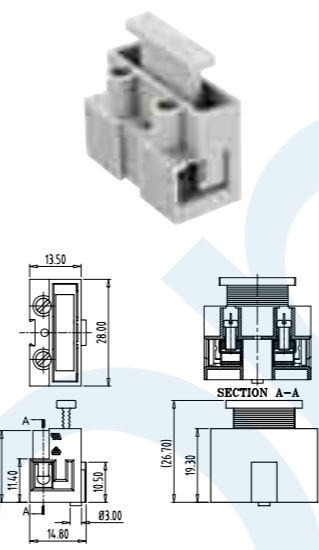

技术数据 Technical data	
Approval (认证):	UL Fuse
Rated voltage (电压):	300V 250V
Rated current (电流):	13A 6.3A
Wire range (线径):	20-14AWG 0.5-2.5mm ²
Screw (螺丝):	M3
料号 Part Number	
极数 (Poles)	型号 (Model)
01	TLF-100-01P

TLF-100(TLF-100E/TLF-100W/TLF-100S/TLF-100EW/TLF-100SW)

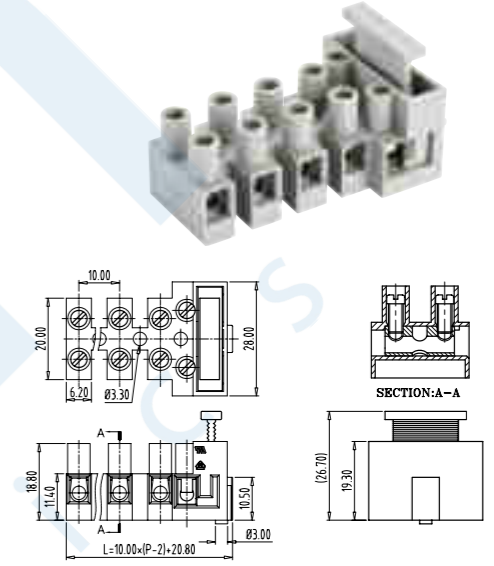

技术数据 Technical data					
Approval (认证):	UL Terminal block	UL Fuse	UL Fuse	UL Fuse	UL Fuse
Rated voltage (电压):	300V	450V	300V	250V	250V
Rated current (电流):	30A	20A(with W)	24A	13A	6.3A
Wire range (线径):	18-10AWG	18-12AWG(with W)	0.5-2.5mm ²	20-14AWG	0.5-2.5mm ²
Screw (螺丝):	M3				
料号 Part Number					
极数 (Poles)	型号 (Model)				
02	TLF-100(TLF-100E)-02P				
:	:				
06	TLF-100(TLF-100E)-06P				

TLF-100-01P+TLF-100-01P

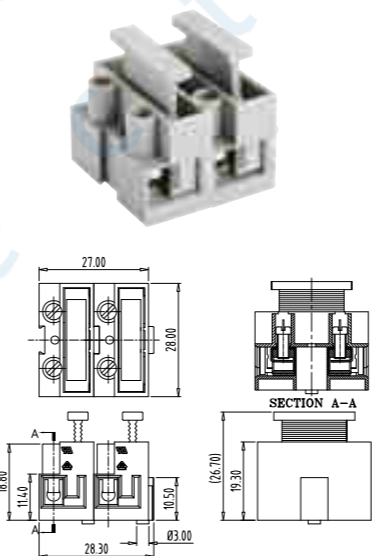

技术数据 Technical data	
Approval (认证):	UL Fuse
Rated voltage (电压):	300V 250V
Rated current (电流):	13A 6.3A
Wire range (线径):	20-14AWG 0.5-2.5mm ²
Screw (螺丝):	M3
型号 (Model)	
TLF-100-01P+TLF-100-01P	

TLF-100-01P+TLF-100(TLF-100E)

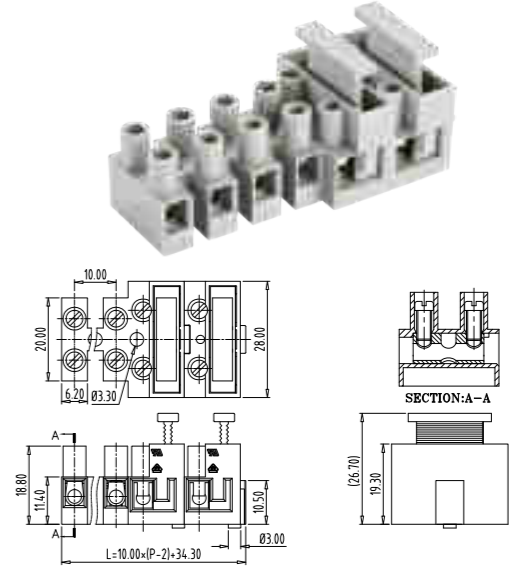

技术数据 Technical data					
Pitch (间距):	10.00mm				
Approval (认证):	UL Terminal block	UL Fuse	UL Fuse	UL Fuse	UL Fuse
Rated voltage (电压):	300V	450V	300V	250V	250V
Rated current (电流):	30A	24A	13A	6.3A	6.3A
Wire range (线径):	18-10AWG	0.5-2.5mm ²	20-14AWG	0.5-2.5mm ²	0.5-2.5mm ²
Screw (螺丝):	M3				
型号 (Model)					
TLF-100-01P+TLF-100(TLF-100E)-02P					
:	:				
TLF-100-01P+TLF-100(TLF-100E)-06P					

FH SERIES – Fuse Holder

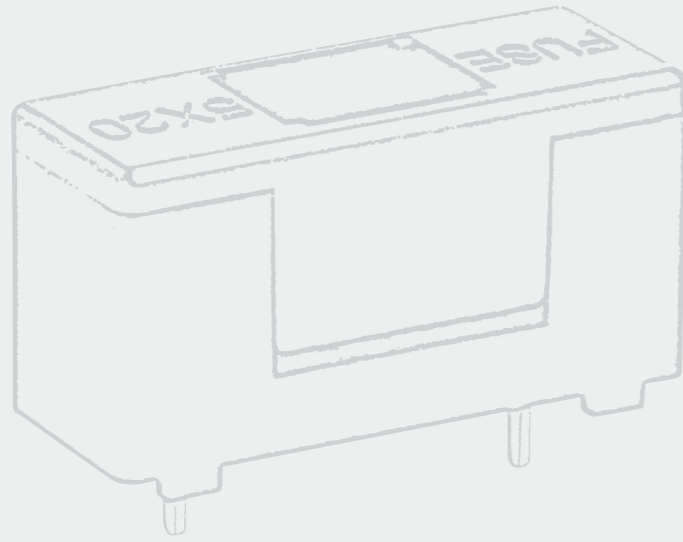

FH-278-A

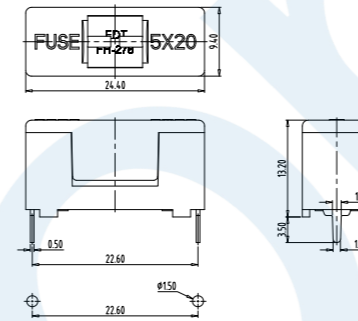

技术数据 Technical data		
Fuse link (保险丝):	Φ5.0*20	
Approval (认证):	UL	VDE
Rated voltage (电压):	250V	250V
Rated current (电流):	10A	6.3A
Rated Power (功率):	1.6W	

FH-278-NA

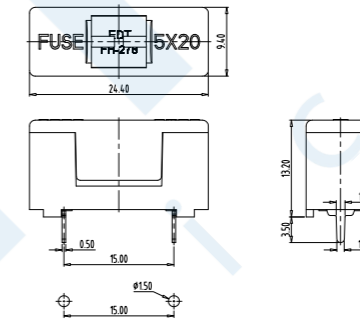

技术数据 Technical data		
Fuse link (保险丝):	Φ5.0*20	
Approval (认证):	UL(Applying)	VDE(Applying)
Rated voltage (电压):	250V	250V
Rated current (电流):	10A	6.3A
Rated Power (功率):	1.6W	

FH-145-A

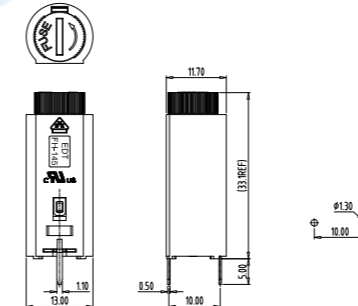

技术数据 Technical data		
Fuse link (保险丝):	Φ5.0*20	
Approval (认证):	UL	VDE
Rated voltage (电压):	250V	250V
Rated current (电流):	10A	10A
Rated Power (功率):	2.5W	

FH-150-A

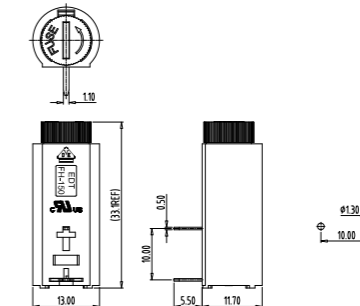

技术数据 Technical data		
Fuse link (保险丝):	Φ5.0*20	
Approval (认证):	UL	VDE
Rated voltage (电压):	250V	250V
Rated current (电流):	10A	10A
Rated Power (功率):	2.5W	

TQQ & TQS SERIES – PCB Fast Connector

TQQ-A-2.8-XXP-X Pitch 5.08mm
 TQQ-B-2.8-XXP-X Pitch 7.62mm
 TQQ-C-2.8-XXP-X Pitch 10.16mm
 TQQ-D-2.8-XXP-X Pitch 12.70mm
 TQQ-E-2.8-XXP-X Pitch 15.24mm

TQQ-A-5.0-XXP-X Pitch 5.08mm
 TQQ-B-5.0-XXP-X Pitch 7.62mm
 TQQ-C-5.0-XXP-X Pitch 10.16mm
 TQQ-D-5.0-XXP-X Pitch 12.70mm
 TQQ-E-5.0-XXP-X Pitch 15.24mm

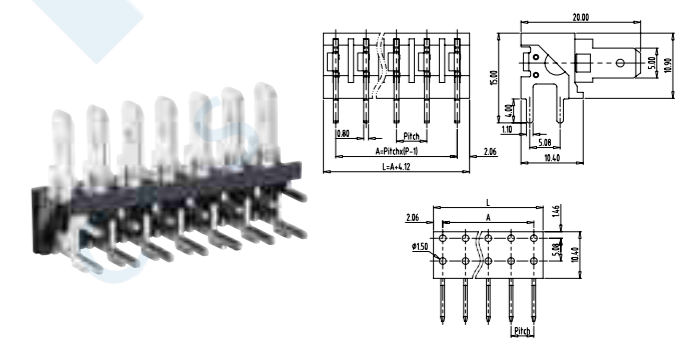
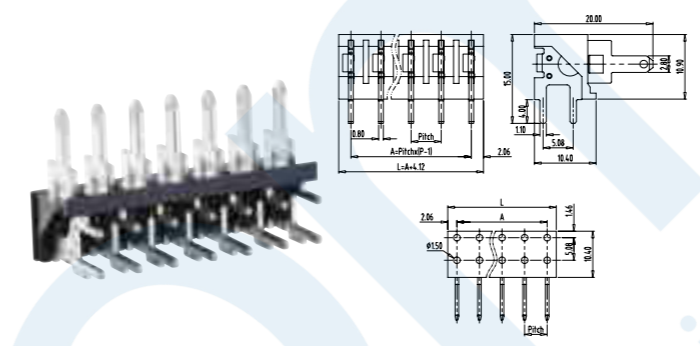

技术数据 Technical data	
Approval (认证):	UL
Housing (材料):	PC UL94V0
Admissible ambient air temperature (适应温度):	-30°C to 125°C
Wire range (端子适用线径 AWG):	18AWG
Standard color (标准颜色):	Black
Rated Current (额定电流):	6A
Rated Voltage (额定电压):	300V AC
Product pitch & poles (产品间距及位数):	5.08 (2P~17P) / 7.62 (2P~11P) / 10.16 (2P~9P) / 12.70 (2P~7P) / 15.24 (2P~6P)

技术数据 Technical data	
Approval (认证):	UL
Housing (材料):	PC UL94V0
Admissible ambient air temperature (适应温度):	-30°C to 125°C
Wire range (端子适用线径 AWG):	16AWG
Standard color (标准颜色):	Black
Rated Current (额定电流):	10A
Rated Voltage (额定电压):	300V AC
Product pitch & poles (产品间距及位数):	5.08 (2P~17P) / 7.62 (2P~11P) / 10.16 (2P~9P) / 12.70 (2P~7P) / 15.24 (2P~6P)

TQQ-A-6.3-XXP-X Pitch 5.08mm
 TQQ-B-6.3-XXP-X Pitch 7.62mm
 TQQ-C-6.3-XXP-X Pitch 10.16mm
 TQQ-D-6.3-XXP-X Pitch 12.70mm
 TQQ-E-6.3-XXP-X Pitch 15.24mm

TQQ-A-2863-XXP-X Pitch 5.08mm
 TQQ-B-2863-XXP-X Pitch 7.62mm
 TQQ-C-2863-XXP-X Pitch 10.16mm
 TQQ-D-2863-XXP-X Pitch 12.70mm
 TQQ-E-2863-XXP-X Pitch 15.24mm

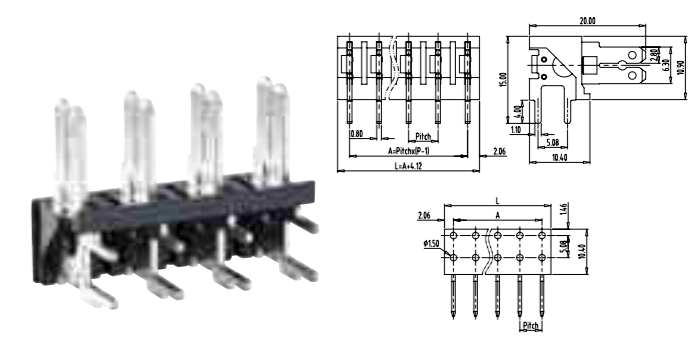
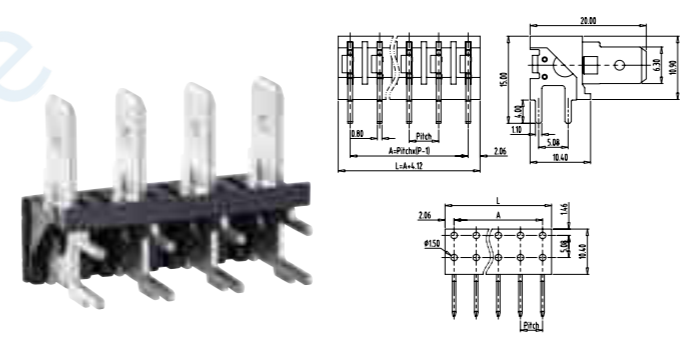

技术数据 Technical data	
Approval (认证):	UL
Housing (材料):	PC UL94V0
Admissible ambient air temperature (适应温度):	-30°C to 125°C
Wire range (端子适用线径 AWG):	14AWG
Standard color (标准颜色):	Black
Rated Current (额定电流):	16A
Rated Voltage (额定电压):	300V AC
Product pitch & poles (产品间距及位数):	5.08 (2P~17P) / 7.62 (2P~11P) / 10.16 (2P~9P) / 12.70 (2P~7P) / 15.24 (2P~6P)

技术数据 Technical data	
Approval (认证):	UL
Housing (材料):	PC UL94V0
Admissible ambient air temperature (适应温度):	-30°C to 125°C
Wire range (端子适用线径 AWG):	14AWG
Standard color (标准颜色):	Black
Rated Current (额定电流):	16A
Rated Voltage (额定电压):	300V AC
Product pitch & poles (产品间距及位数):	5.08 (2P~17P) / 7.62 (2P~11P) / 10.16 (2P~9P) / 12.70 (2P~7P) / 15.24 (2P~6P)

How to order

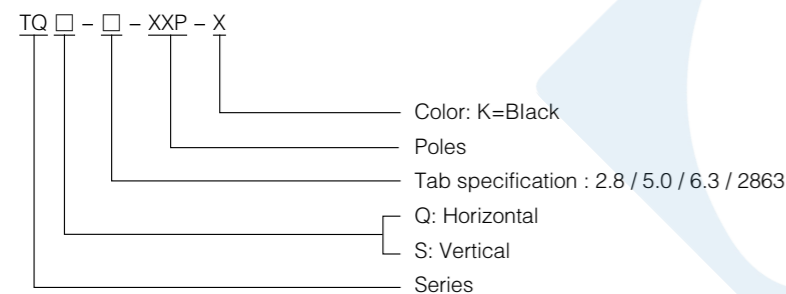

TAB SPECIFICATION

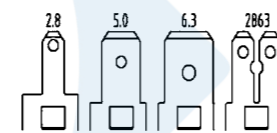

PITCH CODE P

Code/代号	A	B	C	D	E
Pitch/P距	5.08	7.62	10.16	12.70	15.24

TQS-A-2.8-XXP-X Pitch 5.08mm
 TQS-B-2.8-XXP-X Pitch 7.62mm
 TQS-C-2.8-XXP-X Pitch 10.16mm
 TQS-D-2.8-XXP-X Pitch 12.70mm
 TQS-E-2.8-XXP-X Pitch 15.24mm

TQS-A-5.0-XXP-X Pitch 5.08mm
 TQS-B-5.0-XXP-X Pitch 7.62mm
 TQS-C-5.0-XXP-X Pitch 10.16mm
 TQS-D-5.0-XXP-X Pitch 12.70mm
 TQS-E-5.0-XXP-X Pitch 15.24mm

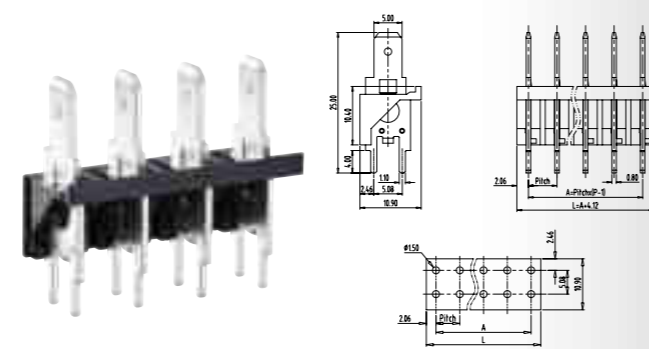
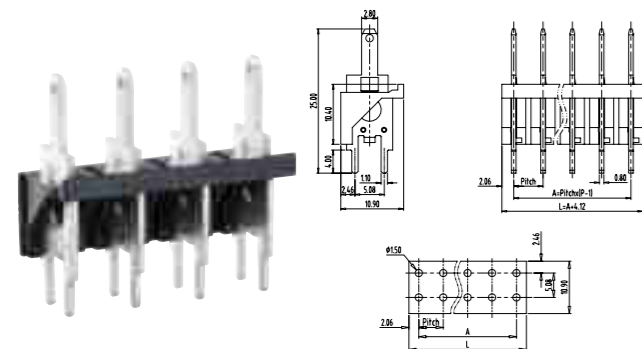

技术数据 Technical data	
Approval (认证):	UL
Housing (材料):	PC UL94V0
Admissible ambient air temperature (适应温度):	-30°C to 125°C
Wire range (端子适用线径 AWG):	18AWG
Standard color (标准颜色):	Black
Rated Current (额定电流):	6A
Rated Voltage (额定电压):	300V AC
Product pitch & poles (产品间距及位数):	5.08 (2P~17P) / 7.62 (2P~11P) / 10.16 (2P~9P) / 12.70 (2P~7P) / 15.24 (2P~6P)

技术数据 Technical data	
Approval (认证):	UL
Housing (材料):	PC UL94V0
Admissible ambient air temperature (适应温度):	-30°C to 125°C
Wire range (端子适用线径 AWG):	16AWG
Standard color (标准颜色):	Black
Rated Current (额定电流):	10A
Rated Voltage (额定电压):	300V AC
Product pitch & poles (产品间距及位数):	5.08 (2P~17P) / 7.62 (2P~11P) / 10.16 (2P~9P) / 12.70 (2P~7P) / 15.24 (2P~6P)

TQS-A-6.3-XXP-X Pitch 5.08mm
 TQS-B-6.3-XXP-X Pitch 7.62mm
 TQS-C-6.3-XXP-X Pitch 10.16mm
 TQS-D-6.3-XXP-X Pitch 12.70mm
 TQS-E-6.3-XXP-X Pitch 15.24mm

TQS-A-2863-XXP-X Pitch 5.08mm
 TQS-B-2863-XXP-X Pitch 7.62mm
 TQS-C-2863-XXP-X Pitch 10.16mm
 TQS-D-2863-XXP-X Pitch 12.70mm
 TQS-E-2863-XXP-X Pitch 15.24mm

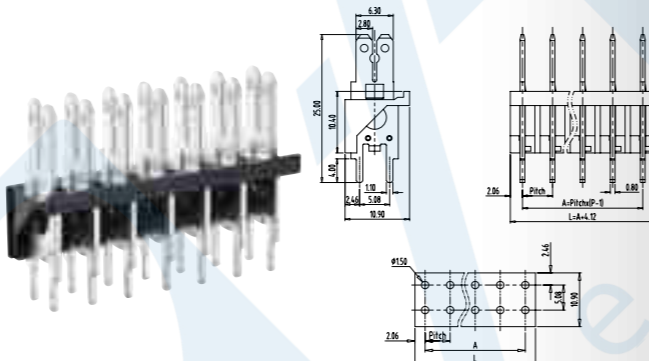
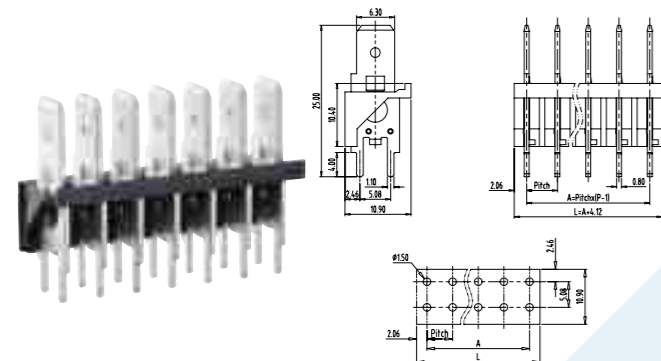

技术数据 Technical data	
Approval (认证):	UL
Housing (材料):	PC UL94V0
Admissible ambient air temperature (适应温度):	-30°C to 125°C
Wire range (端子适用线径 AWG):	14AWG
Standard color (标准颜色):	Black
Rated Current (额定电流):	16A
Rated Voltage (额定电压):	300V AC
Product pitch & poles (产品间距及位数):	5.08 (2P~17P) / 7.62 (2P~11P) / 10.16 (2P~9P) / 12.70 (2P~7P) / 15.24 (2P~6P)

技术数据 Technical data	
Approval (认证):	UL
Housing (材料):	PC UL94V0
Admissible ambient air temperature (适应温度):	-30°C to 125°C
Wire range (端子适用线径 AWG):	14AWG
Standard color (标准颜色):	Black
Rated Current (额定电流):	16A
Rated Voltage (额定电压):	300V AC
Product pitch & poles (产品间距及位数):	5.08 (2P~17P) / 7.62 (2P~11P) / 10.16 (2P~9P) / 12.70 (2P~7P) / 15.24 (2P~6P)

Customized products

At Tianli, we are continually developing various kinds of products to provide more choices for our customers.

Tianli can also offer the manufacture of special products according to a customer's own design. We have a large Design Department, equipped with the latest design aids, and we also have our own assembly and moulding machinery in-house. Based on these, we can maximumly reduce our development cost.

Because we deem quality as the most important service we can offer to our customers, both the present and future clients can be assured of complete satisfaction.

Terminal Project



Plastic Molding / Injection



Stamping Project



Plugs 接线母端	PCB Headers 接线公端	TLPH-400V TLPHC-400V TLPH-400R TLPHC-400R	TLPHW-400V TLPHW-400R	TLPH-500V TLPHC-500V TLPH-500R TLPHC-500R TLPH-500RL TLPHC-500RL	TLPHW-500V TLPHW-500R TLPHW-500RL	TLPHC-501V TLPHC-501R TLPHC-501RL	TLPHW-501V TLPHW-501R TLPHW-501RL
TLPS-400V		•					
TLPS-400R		•					
TLPS-400RL		•					
TLPSW-400V			•				
TLPSW-400R			•				
TLPSW-400RL			•				
TLPS-500V				•			
TLPS-500R				•			
TLPS-500RL				•			
TLPSW-500V					•		
TLPSW-500R					•		
TLPSW-500RL					•		
TLPS-501						•	
TLPSW-501							•
TLPS-502				•			
TLPS-505V				•			
TLPS-505R				•			
TLPSW-505V					•		
TLPSW-505R					•		
TLPS-516V							
TLPSW-516V							
TLPS-800V							
TLPSW-800V							
TLPS-900V							
TLPSW-900V							

TLPHC-516V TLPHC-516R	TLPHW-516V TLPHW-516R	TLPHC-800V TLPHC-800R TLPHC-800RL	TLPHW-800V TLPHW-800R TLPHW-800RL	TLPHC-900V TLPHC-900R	TLPHW-900V TLPHW-900R
•					
	•				
		•			
			•		
				•	
					•

TLC series cross reference list

Plugs 接线母端	Headers 接线公端	TLCP-002	TLCP-001	TLCPL-001	TLCP-100	TLCPL-100	TLCP-200	TLCP-200A	TLCP-200F	TLCP-200FA	TLCPM-200	TLCPM-200A	TLCPL-200	TLCPL-200A	TLCP-300	TLCP-300F	TLCPM-300	TLCPW-300	
TLCH-002V	•																		
TLCH-002R	•																		
TLCH-003	•																		
TLCH-001V		•	•																
TLCH-001R		•	•																
TLCH-100V				•	•														
TLCH-100R				•	•														
TLCH-200V						•		•					•						
TLCH-200R						•		•					•						
TLCH-200VA							•		•				•						
TLCH-200RA								•		•			•						
TLCHM-200V											•								
TLCHM-200R											•								
TLCHM-200VA												•							
TLCH-300V													•		•				
TLCH-300R													•		•				
TLCHM-300V														•					
TLCHM-300R														•					
TLCHW-300V																	•		
TLCH-400V															•				
TLCH-400R															•				
TLCH-400VA															•				
TLCH-400RA															•				
TLCHM-400V																•			
TLCHM-400R																•			
TLCHM-400VA																	•		
TLCH-500V																		•	
TLCH-500R																		•	
TLCHM-500V																			•
TLCHM-500R																			•
TLCHM-202																			•
TLCH-203																			•
TLCH-403																			•
TLCH-403L																			•

TLCPL-300	TLCP-400	TLCP-400A	TLCP-400F	TLCP-400FA	TLCPM-400	TLCPM-400A	TLCPL-400	TLCPL-400A	TLCP-500	TLCP-500F	TLCPM-500	TLCPL-500	TLCPM-201	TLCP-203	TLCP-403	TLCP-403L
•																
•																
	•															
	•															
		•														
		•														
			•													
			•													
				•												
					•											
						•										
							•									
								•								
									•							
										•						
											•					
												•				
													•			
														•		
															•	
																•