



# GW1N series of FPGA Products

## Data Sheet

**DS100-3.2.2E, 02/02/2024**

**Copyright © 2024 Guangdong Gowin Semiconductor Corporation. All Rights Reserved.**

**GOWIN**高云, Gowin, and LittleBee are trademarks of Guangdong Gowin Semiconductor Corporation and are registered in China, the U.S. Patent and Trademark Office, and other countries. All other words and logos identified as trademarks or service marks are the property of their respective holders. No part of this document may be reproduced or transmitted in any form or by any means, electronic, mechanical, photocopying, recording or otherwise, without the prior written consent of GOWINSEMI.

### **Disclaimer**

GOWINSEMI assumes no liability and provides no warranty (either expressed or implied) and is not responsible for any damage incurred to your hardware, software, data, or property resulting from usage of the materials or intellectual property except as outlined in the GOWINSEMI Terms and Conditions of Sale. GOWINSEMI may make changes to this document at any time without prior notice. Anyone relying on this documentation should contact GOWINSEMI for the current documentation and errata.



ALCOB  
e - e - c - t - r - o - n - i - c - s

## Revision History

Date	Version	Description
03/31/2016	1.05E	Initial version published.
07/31/2018	1.2E	<ul style="list-style-type: none"> <li>● PLL Structure diagram updated.</li> <li>● User Flash timing parameters added.</li> <li>● Description of GPIO status for blank chips added.</li> </ul>
09/08/2018	1.3E	The UG256 package added.
11/27/2018	1.4E	<ul style="list-style-type: none"> <li>● B version devices added.</li> <li>● Bank0 and Bank2 of GW1N-6 and GW1N-9 support I3C OpenDrain/PushPull conversion.</li> <li>● The step delay of IODELAY changed from 25ps to 30 ps.</li> </ul>
01/09/2019	1.5E	Oscillator frequency updated.
02/14/2019	1.6E	<ul style="list-style-type: none"> <li>● Power supplies for UV devices updated;</li> <li>● Recommended Operating Conditions for UV devices updated.</li> <li>● Part naming figures updated.</li> </ul>
06/04/2019	1.7E	<ul style="list-style-type: none"> <li>● Operating temperature changed to Junction temperature.</li> <li>● GW1N-1S added.</li> <li>● Power supply restrictions of Bank0/1/3 in GW1N-6/9 added.</li> <li>● Description of User Flash in GW1N-2/2B/4/4B/6/9 added.</li> </ul>
07/02/2019	1.8E	<ul style="list-style-type: none"> <li>● GW1N-6/9 MG196, UG169, and EQ144 added.</li> <li>● GW1N-1S CS30 added.</li> </ul>
10/10/2019	1.9E	<ul style="list-style-type: none"> <li>● GW1N-1 LQ100X-LV and LQ100X-UV added.</li> <li>● BSRAMs in GW1N-1S do not support Dual port mode.</li> <li>● The package sizes of LQ100 / LQ144 / EQ144 / LQ176 / EQ176 fixed.</li> <li>● Junction temperature of automotive operation added.</li> <li>● Power supply ramp rates updated.</li> </ul>
11/15/2019	2.0E	<ul style="list-style-type: none"> <li>● The number of Maximum I/Os updated.</li> <li>● Automotive grade description added to 5.1 Part Name.</li> <li>● IODELAY description added.</li> </ul>
01/15/2020	2.1E	<ul style="list-style-type: none"> <li>● The package name of LQ100X-LV and LQ100X-UV updated.</li> <li>● GW1N-4 MG132X added.</li> </ul>
03/16/2020	2.2E	<ul style="list-style-type: none"> <li>● GW1N-9 CS81M added.</li> <li>● Description of PLL CLKIN frequency updated.</li> </ul>
04/16/2020	2.3E	<ul style="list-style-type: none"> <li>● GW1N-2/GW1N-2B/GW1N-6 removed.</li> <li>● CFU view updated.</li> <li>● GW1N-9C added.</li> </ul>
09/30/2020	2.4E	<ul style="list-style-type: none"> <li>● GW1N-2 added.</li> <li>● GW1N-9 MG100 added.</li> <li>● GW1N-9 QN48F added.</li> </ul>
04/06/2021	2.5E	GW1N-1P5 added.
05/27/2021	2.6E	<ul style="list-style-type: none"> <li>● GW1N-1P5 LQ100 added.</li> <li>● GW1N-2 MG132/LQ100/LQ144 added. MG132 renamed to MG132H, QN48M renamed to QN48H.</li> <li>● GW1N-9 MG100T added.</li> <li>● GW1N-1 LQ100X removed.</li> </ul>

Date	Version	Description
		<ul style="list-style-type: none"> <li>● "Table 2-3 Configuration Modes Supported by Different Packages" added.</li> </ul>
05/20/2022	2.7E	<ul style="list-style-type: none"> <li>● GW1N-4 UG169 added.</li> <li>● GW1N-2 CS42H updated.</li> <li>● The drive strength of MIPI IOs updated.</li> <li>● Recommended I/O operating conditions updated.</li> <li>● On-chip oscillator frequency updated.</li> <li>● Gearbox internal timing parameters updated.</li> </ul>
06/02/2022	2.7.1E	GW1N-1 QN32/QN48/LQ100/LQ144 added.
06/23/2022	2.7.2E	GW1N-1 CS30/FN32 removed.
07/01/2022	2.7.3E	GW1N-1 CS30 added.
07/21/2022	2.8E	<ul style="list-style-type: none"> <li>● GW1N-2 QN32 added.</li> <li>● GW1N-2 CS100H added.</li> <li>● GW1N-2 LQ144F added.</li> <li>● The maximum value of the differential input threshold <math>V_{THD}</math> updated.</li> <li>● Note about loading frequency for the GW1N-2 device added.</li> <li>● Description of configuration modes supported by GW1N-1 CS30 added.</li> <li>● GW1N-1S CS30/FN32 removed.</li> </ul>
08/18/2022	2.8.1E	GW1N-1 QN32/QN48/LQ100/LQ144 removed.
09/29/2022	2.9E	<ul style="list-style-type: none"> <li>● Note about DC current limit added.</li> <li>● Table 3-2 Recommended Operating Conditions updated.</li> <li>● Note about Vcc of GW1N-4/GW1N-9 UV version devices added.</li> <li>● Architecture overviews updated.</li> <li>● Table 3-5 POR Parameters updated.</li> <li>● Table 3-9 Static Current updated.</li> <li>● 3.4 Switching Characteristics updated.</li> </ul>
11/11/2022	2.9.1E	<ul style="list-style-type: none"> <li>● Table 3-3 Power Supply Ramp Rates updated.</li> <li>● Table 3-8 DC Electrical Characteristics over Recommended Operating Conditions updated.</li> <li>● Description of configuration Flash added.</li> <li>● Note about byte-enable added.</li> </ul>
11/21/2022	2.9.2E	<ul style="list-style-type: none"> <li>● Table 3-1 Absolute Max. Ratings updated.</li> <li>● Table 3-9 Static Current updated.</li> <li>● Description of the background upgrade feature in section 2.12 Programming &amp; Configuration updated.</li> </ul>
12/08/2022	2.9.3E	<ul style="list-style-type: none"> <li>● Table 3-1 Absolute Max. Ratings updated.</li> <li>● Table 3-22 GW1N-1/1S User Flash DC Characteristics updated.</li> <li>● Table 3-23 GW1N-2/4/9 User Flash DC Characteristics(I) added.</li> <li>● Table 3-24 GW1N-2/4/9 User Flash DC Characteristics<sup>(1)(1), [4]</sup> updated.</li> <li>● Note for Table 2-4 Memory Size Configuration modified.</li> </ul>
12/19/2022	2.9.4E	GW1N-1P5 QN48XF added.
01/12/2023	2.9.5E	<ul style="list-style-type: none"> <li>● Table 1-2 Device-Package Combinations, Maximum User I/Os, and (True LVDS Pairs updated.</li> </ul>

Date	Version	Description
		<ul style="list-style-type: none"> <li>● Table 3-8 DC Electrical Characteristics over Recommended Operating Conditions updated.</li> </ul>
02/22/2023	2.9.6E	<ul style="list-style-type: none"> <li>● Information on Slew Rate removed.</li> <li>● Table 3-26 GW1N-1P5/2/4/9 User Flash Parameters updated.</li> <li>● Description added to 2.5User Flash(GW1N-1/1S) and 2.6User Flash(GW1N-1P5/2/4/9).</li> <li>● Description of true LVDS design modified.</li> </ul>
04/13/2023	2.9.7E	<ul style="list-style-type: none"> <li>● Note about the default state of GPIOs modified.</li> <li>● Note for Figure 2-5 CFU Structure View modified.</li> <li>● Table 3-3 Power Supply Ramp Rates updated.</li> <li>● The I/O logic output diagram and the I/O logic input diagram combined into Figure 2-13 I/O Logic Input and Output.</li> <li>● Description of MIPI input/output updated.</li> </ul>
04/27/2023	2.9.8E	<ul style="list-style-type: none"> <li>● Description of Flash resources updated.</li> <li>● Note for Table 2-4 Memory Size Configuration modified.</li> <li>● Description of the <math>V_{CCIO}</math> power supply restrictions of the GW1N-9 device updated.</li> </ul>
05/25/2023	2.9.9E	Section 2.4.2 Memory Configuration Modes added.
06/09/2023	3.0E	Table 2-8 List of GW1N series of FPGA Products that Support MIPI IO Mode added.
08/18/2023	3.1E	<ul style="list-style-type: none"> <li>● Note for Table 1-2 Device-Package Combinations, Maximum User I/Os, and (True LVDS Pairs) optimized.</li> <li>● Note for Table 3-8 DC Electrical Characteristics over Recommended Operating Conditions modified.</li> <li>● Table 3-26 GW1N-1P5/2/4/9 User Flash Parameters updated.</li> <li>● Figure 4-3 Package Marking Examples updated.</li> <li>● Note about the default state of GPIOs optimized.</li> <li>● Editorial updates.</li> </ul>
11/30/2023	3.2E	<ul style="list-style-type: none"> <li>● GW1N-1 QN32/QN48/LQ100/LQ144 removed.</li> <li>● Table 1-1 Product Resources updated.</li> <li>● Section 2.4.7 Power up Conditions removed.</li> <li>● Note added to Table 2-1 Output I/O Standards and Configuration Options and Table 3-12 Single-ended I/O DC Characteristics.</li> <li>● Note added to Table 3-2 Recommended Operating Conditions.</li> <li>● Table 3-17 Gearbox Timing Parameters optimized.</li> <li>● Description of the <math>V_{CCIO}</math> power supply restrictions of the GW1N-9 device optimized.</li> <li>● Description of Flash resources updated.</li> </ul>
12/14/2023	3.2.1E	Table 1-2 Device-Package Combinations, Maximum User I/Os, and (True LVDS Pairs) updated, correcting the numbers of maximum user IOs of the GW1N-2 device in CS42H and CS100H packages.
02/02/2024	3.2.2E	<ul style="list-style-type: none"> <li>● “Table 1-2 Device-Package Combinations, Maximum User I/Os, and (True LVDS Pairs)” updated, correcting size information of GW1N-1 CS30.</li> <li>● Added note to “Table 2-4 Memory Size Configuration” , adding information on devices that do not support ROM mode.</li> <li>● “Table 3-1 Absolute Max. Ratings” and “Table 3-2 Recommended Operating Conditions” updated, adding voltage</li> </ul>

Date	Version	Description
		information for hard core MIPI D-PHY.



# Contents

<b>Contents .....</b>	<b>i</b>
<b>List of Figures .....</b>	<b>iv</b>
<b>List of Tables .....</b>	<b>vi</b>
<b>1 General Description.....</b>	<b>1</b>
1.1 Features.....	1
1.2 Product Resources .....	3
1.3 Package Information.....	4
<b>2 Architecture.....</b>	<b>7</b>
2.1 Architecture Overview.....	7
2.2 Configurable Function Units .....	10
2.3 Input/Output Blocks .....	11
2.3.1 I/O Standards.....	12
2.3.2 True LVDS Design .....	20
2.3.3 I/O Logic .....	20
2.3.4 I/O Logic Modes.....	23
2.4 Block SRAM.....	23
2.4.1 Introduction.....	23
2.4.2 Memory Configuration Modes .....	24
2.4.3 Mixed Data Width Configuration.....	25
2.4.4 Byte-enable.....	26
2.4.5 Parity Bit .....	26
2.4.6 Synchronous Operation.....	26
2.4.7 BSRAM Operation Modes .....	27
2.4.8 Clock Mode.....	28
2.5 User Flash(GW1N-1/1S) .....	30
2.6 User Flash(GW1N-1P5/2/4/9) .....	30
2.7 Digital Signal Processing.....	31
2.7.1 Macro.....	31
2.7.2 DSP Operation Modes.....	32
2.8 MIPI D-PHY .....	32
2.8.1 Hard MIPI D-PHY RX core(GW1N-2).....	32

2.8.2 GPIOs support MIPI D-PHY RX/TX.....	32
2.9 Clocks .....	33
2.9.1 Global Clocks.....	33
2.9.2 PLLs.....	33
2.9.3 High-speed Clocks.....	34
2.10 Long Wires.....	36
2.11 Global Set/Reset.....	36
2.12 Programming & Configuration .....	37
2.13 On-chip Oscillator .....	37
<b>3 AC/DC Characteristics .....</b>	<b>40</b>
3.1 Operating Conditions.....	40
3.1.1 Absolute Max. Ratings.....	40
3.1.2 Recommended Operating Conditions .....	40
3.1.3 Power Supply Ramp Rates .....	41
3.1.4 Hot Socketing Specifications .....	42
3.1.5 POR Specifications.....	42
3.2 ESD performance .....	43
3.3 DC Characteristics.....	46
3.3.1 DC Electrical Characteristics over Recommended Operating Conditions .....	46
3.3.2 Static Current.....	47
3.3.3 Programming Current .....	48
3.3.4 Recommended I/O Operating Conditions .....	49
3.3.5 Single-ended I/O DC Characteristics.....	50
3.3.6 Differential I/O DC Characteristics.....	51
3.4 Switching Characteristics .....	52
3.4.1 CFU Switching Characteristics.....	52
3.4.2 BSRAM Switching Characteristics.....	53
3.4.3 DSP Switching Characteristics .....	54
3.4.4 Gearbox Switching Characteristics.....	55
3.4.5 Clock and I/O Switching Characteristics.....	56
3.4.6 On-chip Oscillator Switching Characteristics.....	57
3.4.7 PLL Switching Characteristics .....	58
3.5 User Flash Characteristics .....	59
3.5.1 DC Characteristics.....	59
3.5.2 Timing Parameters.....	61
3.5.3 Timing Diagrams (GW1N-1/ GW1N-1S).....	64
3.5.4 Timing Diagrams (GW1N-1P5/2/4/9).....	65
3.6 Configuration Interface Timing Specification .....	66
<b>4 Ordering Information.....</b>	<b>67</b>



---

4.1 Part Naming .....	67
4.2 Package Markings .....	69
<b>5 About This Guide .....</b>	<b>70</b>
5.1 Purpose .....	70
5.2 Related Documents .....	70
5.3 Terminology and Abbreviations.....	70
5.4 Support and Feedback .....	72

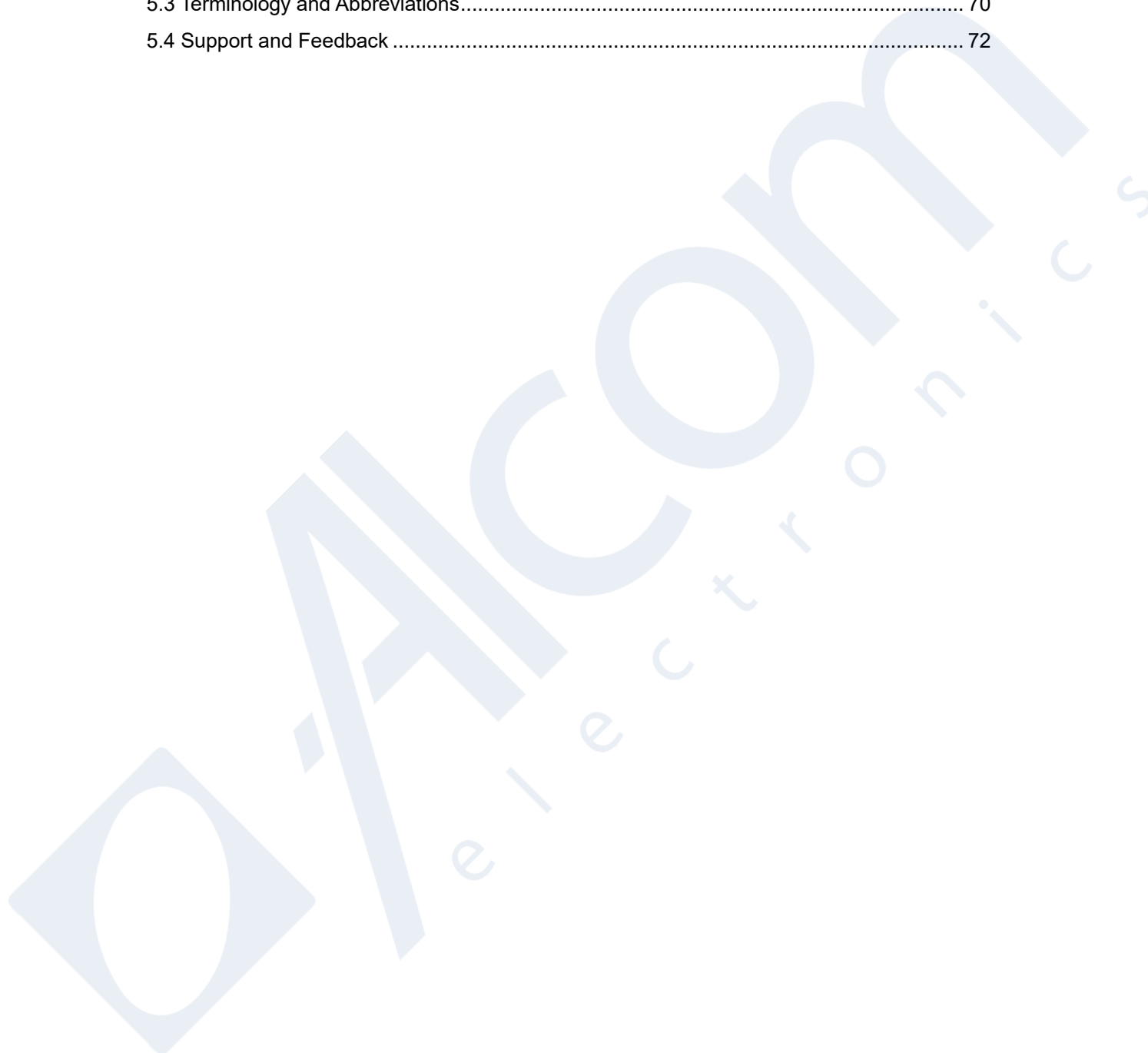

# List of Figures

Figure 2-1 Architecture Overview of GW1N-9 .....	7
Figure 2-2 Architecture Overview of GW1N-4.....	8
Figure 2-3 Architecture Overview of GW1N-1 .....	8
Figure 2-4 Architecture Overview of GW1N-2 .....	9
Figure 2-5 CFU Structure View .....	11
Figure 2-6 IOB Structure View .....	12
Figure 2-7 I/O Bank Distribution View of GW1N-1/4.....	13
Figure 2-8 I/O Bank Distribution View of GW1N-1S .....	13
Figure 2-9 I/O Bank Distribution View of GW1N-1P5 .....	13
Figure 2-10 I/O Bank Distribution View of GW1N-2.....	14
Figure 2-11 I/O Bank Distribution View of GW1N-9.....	14
Figure 2-12 True LVDS Design .....	20
Figure 2-13 I/O Logic Input and Output .....	21
Figure 2-14 IODELAY Diagram.....	22
Figure 2-15 I/O Register Diagram.....	22
Figure 2-16 IEM Diagram.....	23
Figure 2-17 Pipeline Mode in Single Port Mode, Dual Port Mode, and Semi-dual Port Mode .....	27
Figure 2-18 Independent Clock Mode .....	29
Figure 2-19 Read/Write Clock Mode.....	29
Figure 2-20 Single Port Clock Mode .....	29
Figure 2-21 GW1N-1 HCLK Distribution .....	34
Figure 2-22 GW1N-1P5/2 HCLK Distribution .....	35
Figure 2-23 GW1N-4 HCLK Distribution .....	35
Figure 2-24 GW1N-9 HCLK Distribution .....	36
Figure 2-25 GW1N-1S HCLK Distribution .....	36
Figure 3-1 Read Mode .....	64
Figure 3-2 Write Page Latch Mode .....	64
Figure 3-3 Clear Page Latch Mode.....	64
Figure 3-4 High Level Cycles.....	64
Figure 3-5 Read Timing .....	65
Figure 3-6 Program Timing .....	65
Figure 3-7 Erase Timing .....	65

Figure 4-1 Part Naming Examples – ES..... 67  
Figure 4-2 Part Naming Examples – Production ..... 68  
Figure 4-3 Package Marking Examples..... 69



# List of Tables

Table 1-1 Product Resources.....	3
Table 1-2 Device-Package Combinations, Maximum User I/Os, and (True LVDS Pairs).....	4
Table 1-3 Configuration Modes Supported by Different Packages(GW1N-1P5, GW1N2).....	5
Table 2-1 Output I/O Standards and Configuration Options.....	16
Table 2-2 Input I/O Standards and Configuration Options.....	18
Table 2-3 Port Description.....	21
Table 2-4 Memory Size Configuration.....	24
Table 2-5 Dual Port Mixed Read/Write Data Width Configuration <sup>[1],[2]</sup> .....	25
Table 2-6 Semi-dual Port Mixed Read/Write Data Width Configuration.....	26
Table 2-7 Clock Modes in Different BSRAM Modes.....	28
Table 2-8 List of GW1N series of FPGA Products that Support MIPI IO Mode.....	33
Table 2-9 Output Frequency Options of the On-chip Oscillator of GW1N-4.....	38
Table 2-10 Output Frequency Options of the On-chip Oscillator of GW1N-1P5/2/9.....	38
Table 2-11 Output Frequency Options of the On-chip Oscillator of GW1N-1/1S.....	39
Table 3-1 Absolute Max. Ratings.....	40
Table 3-2 Recommended Operating Conditions.....	40
Table 3-3 Power Supply Ramp Rates.....	41
Table 3-4 Hot Socketing Specifications.....	42
Table 3-5 POR Parameters.....	42
Table 3-6 GW1N ESD - HBM.....	43
Table 3-7 GW1N ESD - CDM.....	45
Table 3-8 DC Electrical Characteristics over Recommended Operating Conditions.....	46
Table 3-9 Static Current.....	47
Table 3-10 Programming Current.....	48
Table 3-11 Recommended I/O Operating Conditions.....	49
Table 3-12 Single-ended I/O DC Characteristics.....	50
Table 3-13 Differential I/O DC Characteristics.....	51
Table 3-14 CFU Internal Timing Parameters <sup>[1],[2]</sup> .....	52
Table 3-15 BSRAM Timing Parameters.....	53
Table 3-16 DSP Timing Parameters.....	54
Table 3-17 Gearbox Timing Parameters.....	55
Table 3-18 Single-ended IO Fmax.....	56

Table 3-19 External Switching Characteristics.....	56
Table 3-20 On-chip Oscillator Parameters.....	57
Table 3-21 PLL Parameters .....	58
Table 3-22 GW1N-1/1S User Flash DC Characteristics .....	60
Table 3-23 GW1N-2/4/9 User Flash DC Characteristics(I) .....	60
Table 3-24 GW1N-2/4/9 User Flash DC Characteristics(II) <sup>[1], [4]</sup> .....	60
Table 3-25 GW1N-1/1S User Flash Parameters.....	62
Table 3-26 GW1N-1P5/2/4/9 User Flash Parameters <sup>[1], [4], [5]</sup> .....	62
Table 5-1 Terminology and Abbreviations .....	70

# 1 General Description

The GW1N series of FPGA products are the first generation products in the LittleBee® family. They offer abundant logic resources, multiple I/O standards, embedded BSRAMs, DSPs, PLLs, and built-in Flashes. They are non-volatile FPGA products featuring low power, instant-on, low-cost, enhanced security, small footprint, various packaging options, and flexible usage.

GOWINSEMI provides a new generation of FPGA hardware development environment that supports FPGA synthesis, placement & routing, bitstream generation and download, etc.

## 1.1 Features

- Lower power consumption
  - 55nm embedded flash technology
  - LV<sup>[1]</sup>: Supports 1.2V core voltage
  - UV: Supports unique power supplies for V<sub>CC</sub>/ V<sub>CCIO</sub>/ V<sub>CCX</sub>
- User Flash (GW1N-1, GW1N-1S)
  - NOR Flash
  - 100,000 write cycles
  - Greater than 10 years of data retention at +85°C
  - Selectable input/output data widths of 8/16/32 bits
  - Page size: 256 bytes
- Standby current: 3μA
- Page write time: 8.2ms
- User Flash (GW1N-1P5/2/4/9)
  - NOR Flash
  - 10,000 write cycles
  - Greater than 10 years of data retention at +85°C
  - Data width: 32 bits
  - Capacity in GW1N-1P5/2: 96 Kbits
  - Capacity in GW1N-4: 256 Kbits
  - Capacity in GW1N-9: 608 Kbits
  - Page Erase Capability: 2,048 bytes per page
  - Word Program Time: ≤16μs
  - Page Erase Time: ≤120ms
- Configuration Flash (GW1N-1,

### Note!

GW1N-1S supports LV version only.

- Supports dynamically turning on/off the clock

- GW1N-1S)
- NOR Flash
  - 100,000 write cycles
  - Greater than 10 years of data retention at +85°C
- Configuration Flash (GW1N-1P5/2/4/9)
    - NOR Flash
    - 10,000 write cycles
    - Greater than 10 years of data retention at +85°C
  - Hard MIPI D-PHY RX core(GW1N-2)
    - Supports MIPI DSI and MIPI CSI-2 RX
    - IO Bank6 in CS42, CS42H, QN48H, QN88, and MG132H packages supports MIPI D-PHY RX
    - MIPI data rate up to 2Gbps per lane
    - Supports up to 4 data lanes and 1 clock lane
  - GPIOs support MIPI D-PHY RX/TX
    - Supports MIPI CSI-2 and MIPI DSI RX/TX with a data rate of up to 1.2Gbps per lane
- Note!**  
The GPIOs of the GW1N series of FPGA products support MIPI transmission by using the MIPI IO mode, see Table 2-8 for more details.
- Multiple I/O standards
    - LVCMOS33/25/18/15/12; LVTTTL33, SSTL33/25/18 I, SSTL33/25/18 II, SSTL15; HSTL18 I, HSTL18 II, HSTL15 I; PCI, LVDS25, RSDS, LVDS25E, BLVDSE, MLVDSE,
  - LVPECLE, RSDSE
    - Input hysteresis options
    - Drive strength options
    - Individual Bus Keeper, Pull-up/Pull-down, and Open Drain options
    - Hot socketing
  - High-performance DSP blocks(GW1N-4/9)
    - High-performance digital signal processing
    - Supports 9 x 9, 18 x 18, 36 x 36 bit multipliers and 54-bit accumulators
    - Supports cascading of multipliers
    - Supports pipeline mode and bypass mode
    - Pre-addition operation for the filter function
    - Supports barrel shifters
  - Abundant basic logic cells
    - 4-input LUTs (LUT4s)
    - Supports shift registers and shadow SRAMs
  - Block SRAMs with multiple modes
    - Supports Dual Port mode, Single Port mode, and Semi-Dual Port mode
    - Supports byte-enable
  - Flexible PLLs
    - Frequency adjustment (multiplication and division) and phase adjustment
    - Supports global clocks
  - Built-in Flash programming
    - Instant-on
    - Supports security bit operation

- Supports AUTO BOOT and DUAL BOOT
- Configuration
  - JTAG configuration
  - Supports background upgrade
- Supports up to seven GowinCONFIG configuration modes: AUTOBOOT, SSPI, MSPI, CPU, SERIAL, DUAL BOOT, I2C Slave

## 1.2 Product Resources

Table 1-1 Product Resources

Device	GW1N-1	GW1N-1P5	GW1N-2	GW1N-4	GW1N-9	GW1N-1S
LUT4s	1,152	1,584	2,304	4,608	8,640	1,152
Flip-Flops (FFs)	864	1,584	2,016	3,456	6,480	864
Shadow SRAM(SSRAM) Capacity (bits)	0	12K	18K	0	16K	0
Block SRAM(BSRAM) Capacity(bits)	72K	72K	72K	180K	468K	72K
Number of BSRAMs	4	4	4	10	26	4
User Flash(bits)	96K	96K	96K	256K	608K	96K
Multipliers(18 x 18 Multipliers)	0	0	0	16	20	0
PLLs	1	1	1	2	2	1
I/O Banks	4	6	6 <sup>[2]</sup>	4	4	3
Maximum GPIOs	120	125	125	218	276	44
Core Voltage (LV Version)	1.2V	1.2V	1.2V	1.2V	1.2V	1.2V
Core Voltage (UV Version)	1.8V/2.5V/3.3V <sup>[1]</sup>	1.8V/2.5V/3.3V		1.8V <sup>[3]</sup> /2.5V/3.3V		–

**Note!**

- <sup>[1]</sup> For the GW1N-1 device, only the LQ100X package supports the UV version at present.
- <sup>[2]</sup> The GW1N-2 device in the CS42/QN48H/MG132H/QN88/CS42H packages has seven IO banks.
- <sup>[3]</sup> For UV version GW1N-4/GW1N-9 devices, if V<sub>CC</sub> and V<sub>CCX</sub> share a pin in a package, the V<sub>CCX</sub> range (2.5V~3.3V) of GW1N-4/GW1N-9 will limit the V<sub>CC</sub> range to 2.5 V~3.3V, in this case V<sub>CC</sub> does not support 1.8V.



## 1.3 Package Information

Table 1-2 Device-Package Combinations, Maximum User I/Os, and (True LVDS Pairs)

Package	Pitch(mm)	Size(mm)	GW1N-1S	GW1N-1	GW1N-1P5	GW1N-2	GW1N-4	GW1N-9
CM64	0.5	4.1 x 4.1	-	-	-	-	-	55 (16)
CS100H	0.4	4 x 4	-	-	-	79 (21)	-	-
CS30	0.4	2.3 x 2.2	-	24	-	-	-	-
CS42	0.4	2.4 x 2.9	-	-	-	24 (7)	-	-
CS42H	0.4	2.4 x 2.9	-	-	-	21 (3)	-	-
CS72	0.4	3.6 x 3.3	-	-	-	-	58 (19)	-
CS81M	0.4	4.1 x 4.1	-	-	-	-	-	55 (15)
EQ144	0.5	20 x 20	-	-	-	-	-	121 (28)
EQ176	0.4	20 x 20	-	-	-	-	-	148 (37)
FN32	0.4	4 x 4	-	-	-	-	-	-
LQ100	0.5	14 x 14	-	-	80 (16)	80 (15)	80 (13)	80 (20)
LQ100X	0.5	14 x 14	-	-	80 (16)	80 (15)	-	-
LQ144	0.5	20 x 20	-	-	-	113 (28)	120 (22)	121 (28)
LQ144F	0.5	20 x 20	-	-	-	115 (27)	-	-
LQ144X	0.5	20 x 20	-	-	-	113 (28)	-	-
LQ176	0.4	20 x 20	-	-	-	-	-	147 (37)
MG100	0.5	5 x 5	-	-	-	-	-	87 (25)
MG100T	0.5	5 x 5	-	-	-	-	-	87 (17)
MG121	0.5	6 x 6	-	-	-	100 (28)	-	-
MG121X	0.5	6 x 6	-	-	-	100 (28)	-	-
MG132	0.5	8 x 8	-	-	-	104 (29)	-	-
MG132H	0.5	8 x 8	-	-	-	95 (29)	-	-
MG132X	0.5	8 x 8	-	-	-	104 (29)	105 (23)	-
MG160	0.5	8 x 8	-	-	-	-	132 (25)	132 (38)
MG196	0.5	8 x 8	-	-	-	-	-	113 (35)
MG49	0.5	3.8 x 3.8	-	-	-	42 (11)	-	-
PG256	1.0	17 x 17	-	-	-	-	208 (32)	208 (36)
PG256M	1.0	17 x 17	-	-	-	-	208 (32)	-

Package	Pitch(mm)	Size(mm)	GW1N-1S	GW1N-1	GW1N-1P5	GW1N-2	GW1N-4	GW1N-9
QN32	0.5	5 x 5	-	-	-	21 (1)	24 (3)	-
QN32X	0.5	5 x 5	-	-	-	21 (1)	-	-
QN48	0.4	6 x 6	-	-	-	41 (12)	40 (9)	40 (12)
QN48F	0.4	6 x 6	-	-	-	-	-	40 (11)
QN48H	0.4	6 x 6	-	-	-	31 (8)	-	-
QN48X	0.5	7 x 7	-	-	39 (10)	-	-	-
QN48XF	0.5	7 x 7	-	-	40 (11)	-	-	-
QN88	0.4	10 x 10	-	-	-	58 (17)	71 (11)	71 (19)
UG169	0.8	11 x 11	-	-	-	-	129 (27)	129 (38)
UG256	0.8	14 x 14	-	-	-	-	-	207 (36)
UG332	0.8	17 x 17	-	-	-	-	-	274 (43)

**Note!**

- JTAGSEL\_N and JTAG pins cannot be used as GPIOs simultaneously. However, when mode [2:0] = 001, the JTAGSEL\_N pin is always a GPIO, in other words the JTAGSEL\_N pin and the four JTAG pins (TCK, TMS, TDI, TDO) can be used as GPIOs simultaneously. See [UG103, GW1N series of FPGA Products Package and Pinout](#) for more details.
- The package types in this manual are referred to by abbreviations, see [4.1 Part Naming](#) for more information.
- GW1N-1 CS30 only supports SSPI mode.

**Table1-3 Configuration Modes Supported by Different Packages(GW1N-1P5, GW1N2)**

Device	Package	Mode[2:0]	Configuration Mode	Notes
GW1N-2 <sup>[1]</sup>	QN32 CS42 LQ100 LQ144 LQ144F MG121 MG132	000	JTAG Autoboot	-

Device	Package	Mode[2:0]	Configuration Mode	Notes
	LQ100X LQ144X MG121X MG132X MG49 QN32X CS42H	100	JTAG I <sup>2</sup> C Autoboot	When I <sup>2</sup> C is supported, the SDA and SCL pins need to be pulled up externally. When Mode[2,0] is configured as 100 and Autoboot is used, the SDA pin needs to be pulled up externally.
	QN48 QN48H	00X	JTAG Autoboot SSPI	–
	MG132H CS100H	X0X	JTAG I <sup>2</sup> C Autoboot SSPI	When I <sup>2</sup> C is supported, the SDA and SCL pins need to be pulled up externally. When Mode[2,0] is configured as 100 and Autoboot is used, the SDA pin needs to be pulled up externally.
	QN88	XXX	JTAG I <sup>2</sup> C Autoboot SSPI MSPI DUAL BOOT SERIAL CPU	–
GW1N-1P5	LQ100X QN48X	100	JTAG I <sup>2</sup> C Autoboot	When I <sup>2</sup> C is supported, the SDA and SCL pins need to be pulled up externally. When Mode[2,0] is configured as 100 and Autoboot is used, the SDA pin needs to be pulled up externally.
	LQ100 QN48XF	000	JTAG Autoboot	–

**Note!**

<sup>[1]</sup> For the GW1N-2 device, if its MODE[2] value is fixed to 1, its loading frequency can only be 2.5MHz.

# 2 Architecture

## 2.1 Architecture Overview

Figure 2-1 Architecture Overview of GW1N-9

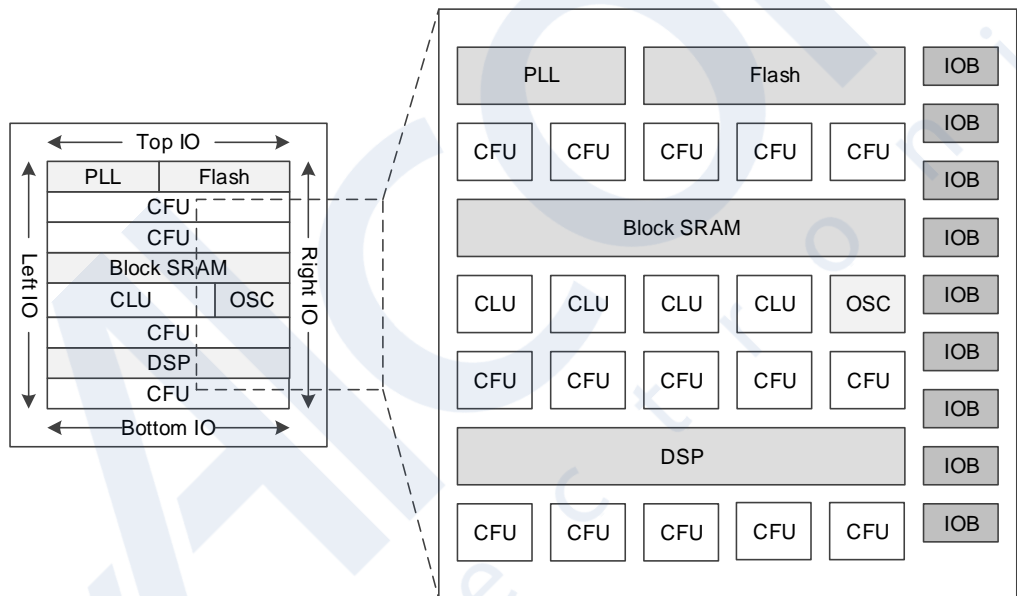

Figure 2-2 Architecture Overview of GW1N-4

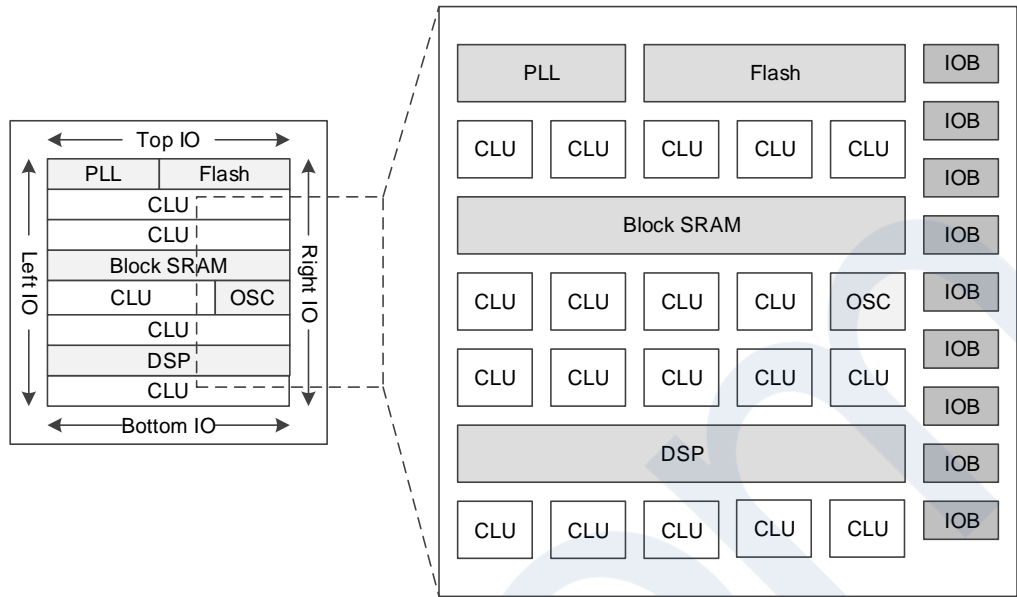

Figure 2-3 Architecture Overview of GW1N-1

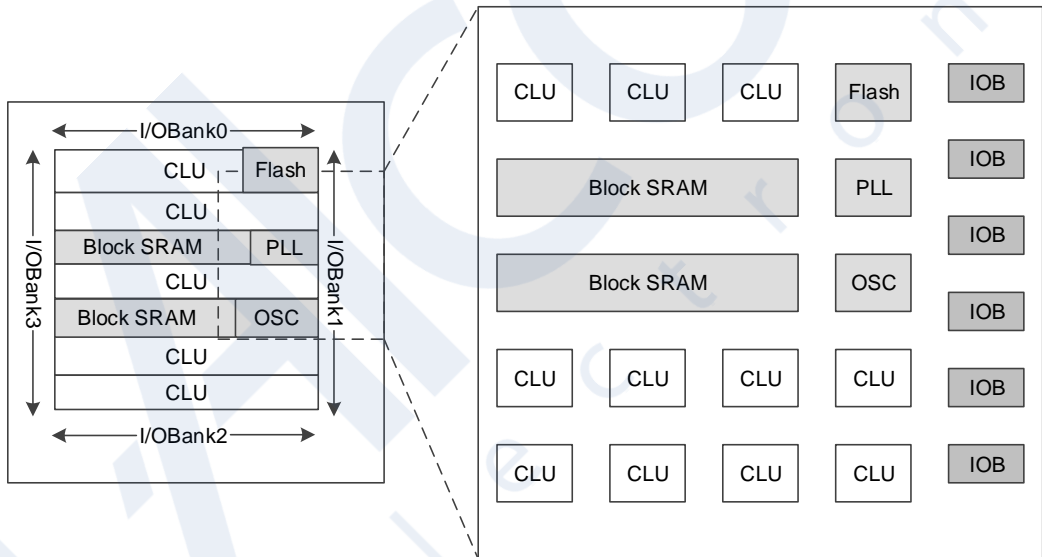
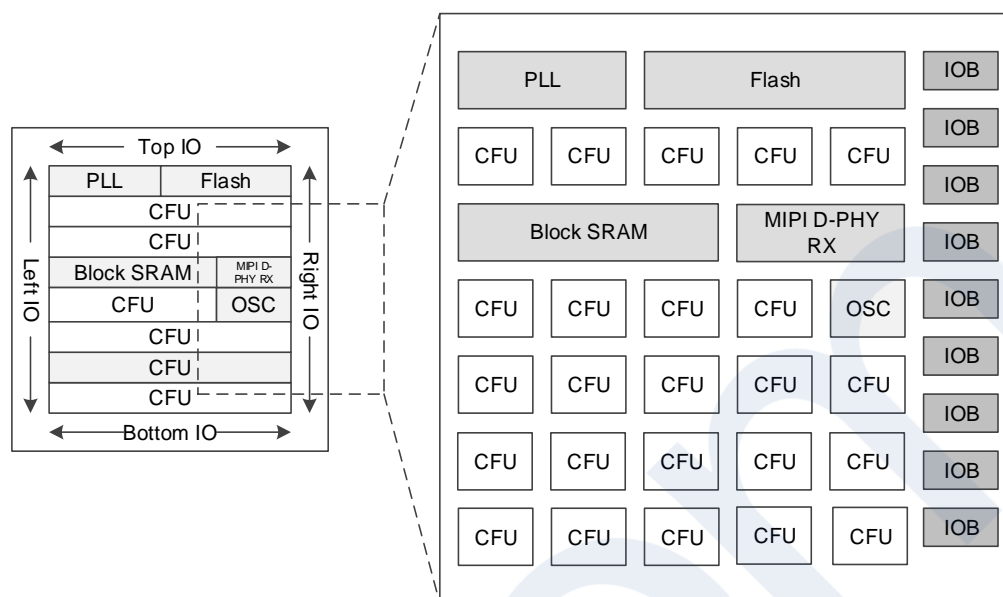

Figure 2-4 Architecture Overview of GW1N-2



As shown in Figure 2-1 to Figure 2-3, the core of the FPGA is an array of logic cells surrounded by IO blocks. Besides, BSRAMs, DSP blocks, PLLs, an on-chip oscillator, and Flash resources that support instant-on are provided. As shown in Figure 2-4, the GW1N-2 device is further embedded with a hard MIPI D-PHY RX core compared with other GW1N devices. See Table 1-1 for more information on the resources provided.

The Configurable Function Unit (CFU) and the Configurable Logic Unit (CLU) are the two kinds of basic logic blocks that form the core of Gowin FPGAs. Devices with different capacities have different numbers of rows and columns of CFUs/CLUs. The CFU can be configured into LUT4 mode, ALU mode, and memory mode. For more information, see [2.2 Configurable Function Units](#).

The I/O resources in the GW1N series of FPGA products are arranged around the periphery of the devices in groups referred to as banks. The I/O resources support multiple I/O standards and can be used for regular mode, SDR mode, and generic DDR mode. For more information, see [2.3 Input/Output Blocks](#).

BSRAMs are embedded as a row in the GW1N series of FPGA products. Each BSRAM has a capacity of 18 Kbits and supports multiple configuration modes and operation modes. For more information, see [2.4 Block SRAM](#).

GW1N-1/1S/1P5/2, GW1N-4, and GW1N-9 feature embedded Flash resources with capacities of 1 Mbits, 2 Mbits, and 4 Mbits respectively. The Flash memory resources consist of configuration Flash resources and user Flash resources. Configuration Flash resources are used for internal Flash programming, see [2.12 Programming & Configuration](#) for more information. User Flash resources are used for user storage, see [2.5 User Flash\(GW1N-1/1S\)](#) and [2.6 User Flash\(GW1N-1P5/2/4/9\)](#) for more information.

GW1N-4 and GW1N-9 provide DSP blocks. Each DSP block contains two macros, and each macro contains two pre-adders, two 18 x 18 bit multipliers, and one three-input ALU. For more information, see [2.7 Digital Signal Processing](#).

**Note!**

GW1N-1, GW1N-2, and GW1N-1S do not support DSP resources currently.

The GW1N series of FPGA products have embedded PLL resources. PLL blocks provide the ability to synthesize clock frequencies. Frequency adjustment (multiplication and division), phase adjustment, and duty cycle adjustment can be realized by the configuration of parameters. In addition, an programmable on-chip oscillator is provided, see [2.9 Clock](#) and [2.13 On-chip Oscillator](#) for more information.

The GW1N-2 device contains a hard MIPI D-PHY RX core, see [2.8 MIPI D-PHY](#) for more information.

There are also abundant Configurable Routing Units (CRUs) that interconnect all the resources within the FPGA. For example, routing resources distributed in CFUs and IOBs interconnect resources in them. Routing resources can be automatically generated by the Gowin software. In addition, the GW1N series of FPGA products also provide abundant dedicated clock resources, long wires (LWs), global set/reset (GSR) resources, programming options, etc. For more information, see [2.9 Clock](#), [2.10 Long Wires](#), and [2.11 Global Set/Reset](#).

## 2.2 Configurable Function Units

Configurable Function Units (CFUs) and/or Configurable Logic Units (CLUs) are the basic cells that make up the core of Gowin FPGAs. Each basic cell consists of four Configurable Logic Sections (CLSs) and their routing resource Configurable Routing Units (CRUs), with three of the CLSs each containing two 4-input LUTs and two registers, and the remaining one only containing two 4-input LUTs, as shown in Figure 2-5 .

The CLSs in the CLUs cannot be configured as SRAMs, but can be configured as basic LUTs, ALUs, and ROMs. The CLSs in the CFUs can be configured as basic LUTs, ALUs, SRAMs, and ROMs according to application scenarios.

For more information on the CFUs, see [UG288, Gowin Configurable Function Unit \(CFU\) User Guide](#).

Figure 2-5 CFU Structure View

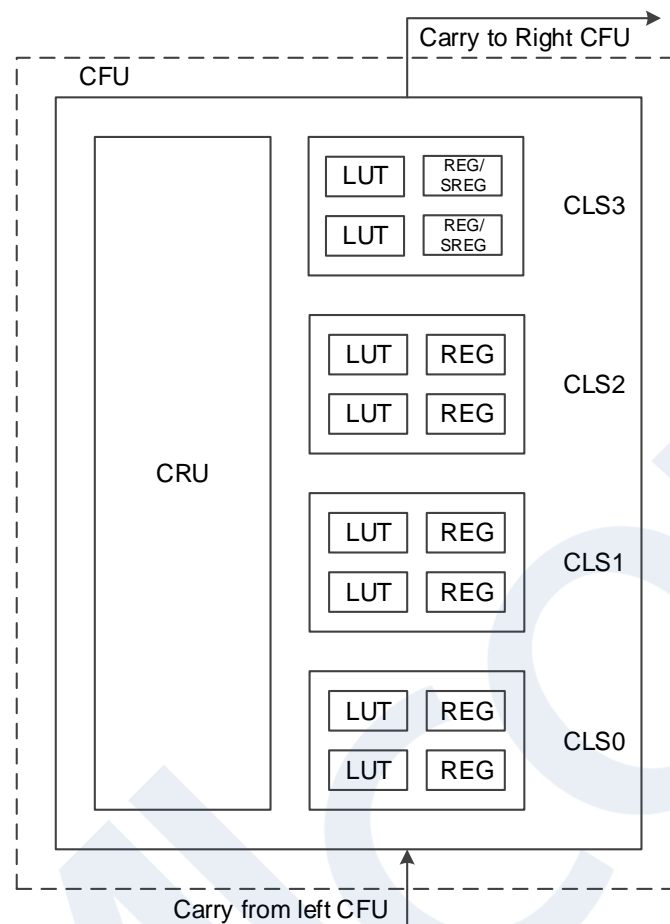
**Note!**

- The SREGs need special patch support. Please contact Gowin's technical support or local office for this patch.
- Only GW1N-1P5 and GW1N-2 support the REGs in CLS3 currently, and the CLK, CE, and SR of CLS3 and CLS2 are driven by the same source.

## 2.3 Input/Output Blocks

The Input/Output Block (IOB) in the GW1N series of FPGA products consists a buffer pair, IO logic, and corresponding routing units. As shown in Figure 2-6 , each IOB connects to two pins (marked as A and B), which



can be used as a differential pair or as two single-ended inputs/outputs.

Figure 2-6 IOB Structure View

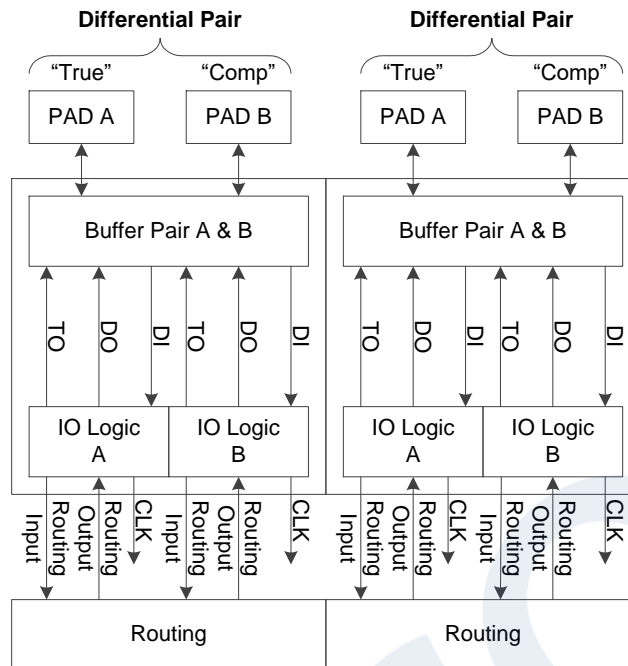

The features of the IOB include:

- $V_{CCIO}$  supplied with each bank
- LVCMOS, PCI, LVTTTL, LVDS, SSTL, HSTL, etc.
- Input hysteresis options
- Drive strength options
- Individual Bus Keeper, Pull-up/Pull-down, and Open Drain options
- Hot socketing
- IO logic supports basic mode, SDR mode, DDR mode, etc.

**Note!**

- The GPIOs of the GW1N series of FPGA products support MIPI transmission by using the MIPI IO mode, see Table 2-8 for more details.
- GW1N-1 and GW1N-1S do not support true LVDS output.
- 2.3.1~ 2.3.4 describe I/O standards, true LVDS design, I/O logic, and I/O logic modes. For more information about the IOB, please refer to [UG289, Gowin Programmable IO \(GPIO\) User Guide](#).

## 2.3.1 I/O Standards

Each Bank has its own I/O power supply  $V_{CCIO}$ .

To support SSTL, HSTL, etc., each bank also has one independent voltage source ( $V_{REF}$ ) as the reference voltage. You can choose to use the internal  $V_{REF}$  ( $0.5 \times V_{CCIO}$ ) or the external  $V_{REF}$  input via any IO from the bank.

There are four IO banks in the GW1N-1/4 devices, as shown in Figure 2-7.

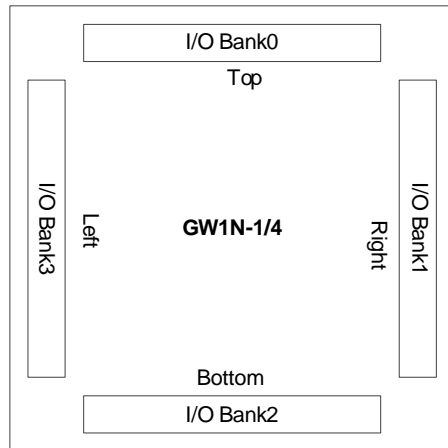
**Figure 2-7 I/O Bank Distribution View of GW1N-1/4**

There are three IO banks in the GW1N-1S device, as shown in Figure 2-8.

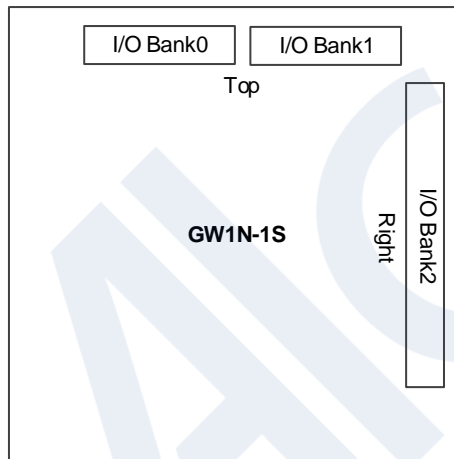
**Figure 2-8 I/O Bank Distribution View of GW1N-1S**

There are six IO banks in the GW1N-1P5 device, as shown in Figure 2-9.

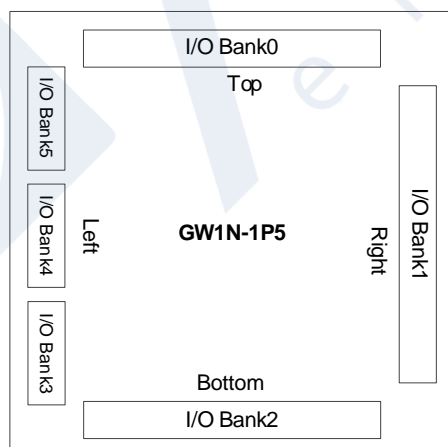
**Figure 2-9 I/O Bank Distribution View of GW1N-1P5**

There are six banks in the GW1N-2 device, while in the case of GW1N-2 in the CS42, QN48H, MG132H, QN88, and CS42H packages,

there are 7 banks, as shown in Figure 2-10.

**Figure 2-10 I/O Bank Distribution View of GW1N-2**

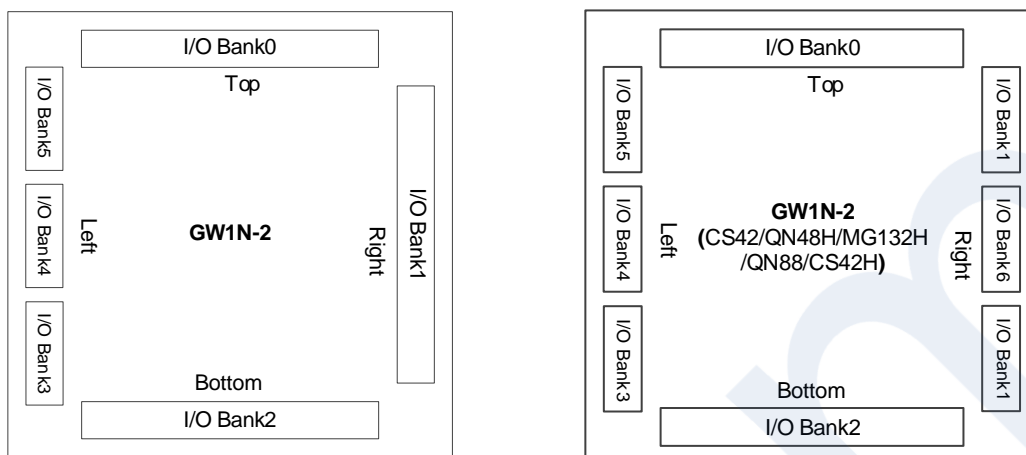

There are four IO banks in the GW1N-9 device, as shown in Figure 2-11.

**Figure 2-11 I/O Bank Distribution View of GW1N-9**

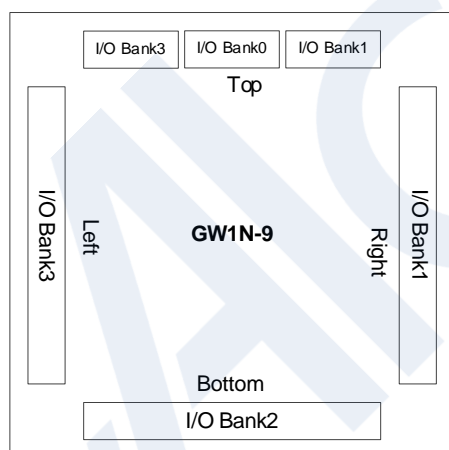

The GW1N series of FPGA products support LV version and UV version, except for GW1N-1S, which only support only LV version.

The LV version devices support 1.2V  $V_{CC}$  for low power consumption.  $V_{CCIO}$  can be set to 1.2V, 1.5V, 1.8V, 2.5V, or 3.3V as needed. GW1N-1S does not support  $V_{CCX}$ , while other devices support 2.5V or 3.3V  $V_{CCX}$ .

The UV version devices support 1.8V, 2.5V, and 3.3V  $V_{CC}$ , and a linear voltage regulator is integrated to facilitate a single power supply.

The GPIOs of the GW1N series of FPGA products support MIPI IO mode, see Table 2-8 for more information.

**Note!**

- During configuration, all GPIOs of the device are high-impedance with internal weak pull-ups. After the configuration is complete, the I/O states are controlled by user programs and constraints. The states of configuration-related I/Os differ depending on the configuration mode.
- For the recommended operating conditions of different devices, please refer to 3.1 Operating Conditions.
- When the I/Os of Bank0/Bank1 of GW1N-1S are used as MIPI input,  $V_{CCIO0}/V_{CCIO1}$  need to be supplied with a 1.2V power supply.
- When the I/Os of Bank0/Bank3/Bank4/Bank5 of GW1N-2/GW1N-1P5 are used as MIPI output,  $V_{CCIO0}/V_{CCIO3}/V_{CCIO4}/V_{CCIO5}$  need to be supplied with a 1.2V power supply.
- When the I/Os of Bank2 of GW1N-2/GW1N-1P5 are used as MIPI input,  $V_{CCIO2}$  needs to be supplied with a 1.2V power supply.
- When the I/Os of Bank0 of GW1N-9 are used as MIPI input,  $V_{CCIO0}$  needs to be supplied with a 1.2V power supply.
- When the I/Os in Bank2 of GW1N-9 are used as MIPI output,  $V_{CCIO2}$  needs to be supplied with a 1.2V power supply.
- The I/O power supply restrictions of Bank0/Bank1/Bank3 in GW1N-9 are as follows (the C version of the GW1N-9 device does not have these power supply restrictions):
  - When  $V_{CCIO0}$  is greater than or equal to 1.8V,  $V_{CCIO1}$  and  $V_{CCIO3}$  support 1.2V, 1.5V, 1.8V, 2.5V, and 3.3V.
  - When  $V_{CCIO0}$  is 1.5V,  $V_{CCIO1}$  and  $V_{CCIO3}$  support 1.2V, 1.5V, 1.8V, and 2.5V.
  - When  $V_{CCIO0}$  is 1.2V,  $V_{CCIO1}$  and  $V_{CCIO3}$  support 1.2V, 1.5V, and 1.8V.

For the  $V_{CCIO}$  requirements of different I/O standards, see Table 2-1 and Table 2-2.

**Table 2-1 Output I/O Standards and Configuration Options**

I/O Type (output)	Single-ended/Differential	Bank $V_{CCIO}(V)$	Drive Strength (mA)	Typical Applications
MIP1 <sup>[1]</sup>	Differential(TLVDS)	1.2	3.5	Mobile Industry Processor Interface
LVDS25 <sup>[2]</sup>	Differential(TLVDS)	2.5/3.3	3.5/2.5/2/1.25	High-speed point-to-point data transmission
RSDS <sup>[2]</sup>	Differential(TLVDS)	2.5/3.3	2	High-speed point-to-point data transmission
MINILVDS <sup>[2]</sup>	Differential(TLVDS)	2.5/3.3	2	LCD timing driver interface and column driver interface
PPLVDS <sup>[2]</sup>	Differential(TLVDS)	2.5/3.3	1.25/2.0/2.5/3.5	LCD row/column driver
LVDS25E	Differential	2.5	8	High-speed point-to-point data transmission
BLVDS25E	Differential	2.5	16	Multi-point high-speed data transmission
MLVDS25E	Differential	2.5	16	LCD timing driver interface and column driver interface
RSDS25E	Differential	2.5	8	High-speed point-to-point data transmission
LVPECL33E	Differential	3.3	16	Universal interface
HSTL18D_I	Differential	1.8	8	Memory interface
HSTL18D_II	Differential	1.8	8	Memory interface
HSTL15D_I	Differential	1.5	8	Memory interface
SSTL15D	Differential	1.5	8	Memory interface
SSTL18D_I	Differential	1.8	8	Memory interface
SSTL18D_II	Differential	1.8	8	Memory interface
SSTL25D_I	Differential	2.5	8	Memory interface
SSTL25D_II	Differential	2.5	8	Memory interface

I/O Type (output)	Single-ended/Differential	Bank V <sub>CCIO</sub> (V)	Drive Strength (mA)	Typical Applications
SSTL33D_I	Differential	3.3	8	Memory interface
SSTL33D_II	Differential	3.3	8	Memory interface
LVC MOS12D	Differential	1.2	4/8	Universal interface
LVC MOS15D	Differential	1.5	4/8	Universal interface
LVC MOS18D	Differential	1.8	4/8/12	Universal interface
LVC MOS25D	Differential	2.5	4/8/12/16	Universal interface
LVC MOS33D	Differential	3.3	4/8/12/16/24 <sup>[3]</sup>	Universal interface
HSTL15_I	Single-ended	1.5	8	Memory interface
HSTL18_I	Single-ended	1.8	8	Memory interface
HSTL18_II	Single-ended	1.8	8	Memory interface
SSTL15	Single-ended	1.5	8	Memory interface
SSTL18_I	Single-ended	1.8	8	Memory interface
SSTL18_II	Single-ended	1.8	8	Memory interface
SSTL25_I	Single-ended	2.5	8	Memory interface
SSTL25_II	Single-ended	2.5	8	Memory interface
SSTL33_I	Single-ended	3.3	8	Memory interface
SSTL33_II	Single-ended	3.3	8	Memory interface
LVC MOS12	Single-ended	1.2	4/8	Universal interface
LVC MOS15	Single-ended	1.5	4/8	Universal interface
LVC MOS18	Single-ended	1.8	4/8/12	Universal interface
LVC MOS25	Single-ended	2.5	4/8/12/16	Universal interface
LVC MOS33/ LV TTL33	Single-ended	3.3	4/8/12/16/24 <sup>[3]</sup>	Universal interface
PCI33	Single-ended	3.3	4/8	PC and embedded system

**Note!**

- <sup>[1]</sup> Bank0/Bank3/Bank4/Bank5 of GW1N-2/GW1N-1P5 and Bank2 of GW1N-9 support MIPI I/O output.
- <sup>[2]</sup> GW1N-1/GW1N-1S do not support this I/O type.
- <sup>[3]</sup> GW1N-1P5 and GW1N-2 do not support 24mA.

Table 2-2 Input I/O Standards and Configuration Options

I/O Type(input)	Single-ended/Differential	Bank V <sub>CCIO</sub> (V)	Supports Hysteresis Options?	Needs V <sub>REF</sub> ?
MIP1 <sup>[1]</sup>	Differential(TLVDS)	1.2	No	No
LVDS25 <sup>[2]</sup>	Differential(TLVDS)	2.5/3.3	No	No
RSDS <sup>[2]</sup>	Differential(TLVDS)	2.5/3.3	No	No
MINILVDS <sup>[2]</sup>	Differential(TLVDS)	2.5/3.3	No	No
PPLVDS <sup>[2]</sup>	Differential(TLVDS)	2.5/3.3	No	No
LVDS25E	Differential	2.5/3.3	No	No
BLVDS25E	Differential	2.5/3.3	No	No
MLVDS25E	Differential	2.5/3.3	No	No
RSDS25E	Differential	2.5/3.3	No	No
LVPECL33E	Differential	3.3	No	No
HSTL18D_I	Differential	1.8/2.5/3.3	No	No
HSTL18D_II	Differential	1.8/2.5/3.3	No	No
HSTL15D_I	Differential	1.5/1.8/2.5/3.3	No	No
SSTL15D	Differential	1.5/1.8/2.5/3.3	No	No
SSTL18D_I	Differential	1.8/2.5/3.3	No	No
SSTL18D_II	Differential	1.8/2.5/3.3	No	No
SSTL25D_I	Differential	2.5/3.3	No	No
SSTL25D_II	Differential	2.5/3.3	No	No
SSTL33D_I	Differential	3.3	No	No
SSTL33D_II	Differential	3.3	No	No
LVC MOS12D	Differential	1.2/1.5/1.8/2.5/3.3	No	No
LVC MOS15D	Differential	1.5/1.8/2.5/3.3	No	No
LVC MOS18D	Differential	1.8/2.5/3.3	No	No
LVC MOS25D	Differential	2.5/3.3	No	No
LVC MOS33D	Differential	3.3	No	No
HSTL15_I	Single-ended	1.5 or 1.5/1.8/2.5/3.3 <sup>[3]</sup>	No	Yes

I/O Type(input)	Single-ended/Differential	Bank V <sub>CCIO</sub> (V)	Supports Hysteresis Options?	Needs V <sub>REF</sub> ?
HSTL18_I	Single-ended	1.8 or 1.8/2.5/3.3 <sup>[4]</sup>	No	Yes
HSTL18_II	Single-ended	1.8 or 1.8/2.5/3.3 <sup>[4]</sup>	No	Yes
SSTL15	Single-ended	1.5 or 1.5/1.8/2.5/3.3 <sup>[3]</sup>	No	Yes
SSTL18_I	Single-ended	1.8 or 1.8/2.5/3.3 <sup>[4]</sup>	No	Yes
SSTL18_II	Single-ended	1.8 or 1.8/2.5/3.3 <sup>[4]</sup>	No	Yes
SSTL25_I	Single-ended	2.5 or 2.5/3.3 <sup>[5]</sup>	No	Yes
SSTL25_II	Single-ended	2.5 or 2.5/3.3 <sup>[5]</sup>	No	Yes
SSTL33_I	Single-ended	3.3	No	Yes
SSTL33_II	Single-ended	3.3	No	Yes
LVC MOS12	Single-ended	1.2/1.5/1.8/2.5/3.3	Yes	No
LVC MOS15	Single-ended	1.2/1.5/1.8/2.5/3.3	Yes	No
LVC MOS18	Single-ended	1.2/1.5/1.8/2.5/3.3	Yes	No
LVC MOS25	Single-ended	1.2/1.5/1.8/2.5/3.3	Yes	No
LVC MOS33/ LV TTL33	Single-ended	1.2/1.5/1.8/2.5/3.3	Yes	No
PCI33	Single-ended	3.3	Yes	No
LVC MOS33OD25	Single-ended	2.5	No	No
LVC MOS33OD18	Single-ended	1.8	No	No
LVC MOS33OD15	Single-ended	1.5	No	No
LVC MOS25OD18	Single-ended	1.8	No	No
LVC MOS25OD15	Single-ended	1.5	No	No
LVC MOS18OD15	Single-ended	1.5	No	No
LVC MOS15OD12	Single-ended	1.2	No	No
LVC MOS25UD33	Single-ended	3.3	No	No
LVC MOS18UD25	Single-ended	2.5	No	No
LVC MOS18UD33	Single-ended	3.3	No	No
LVC MOS15UD18	Single-ended	1.8	No	No
LVC MOS15UD25	Single-ended	2.5	No	No
LVC MOS15UD33	Single-ended	3.3	No	No
LVC MOS12UD15	Single-ended	1.5	No	No
LVC MOS12UD18	Single-ended	1.8	No	No



I/O Type(input)	Single-ended/Differential	Bank $V_{CCIO}$ (V)	Supports Hysteresis Options?	Needs $V_{REF}$ ?
LVC MOS12UD25	Single-ended	2.5	No	No
LVC MOS12UD33	Single-ended	3.3	No	No

**Note!**

- <sup>[1]</sup> Bank2 of GW1N-2/GW1N-1P5, Bank6 (Hard core) of GW1N-2, Bank0 of GW1N-9, and Bank0/ Bank1 of GW1N-1S support MIPI I/O input.
- <sup>[2]</sup> GW1N-1S does not support this I/O type.
- <sup>[3]</sup> When  $V_{REF}$  is INTERNAL,  $V_{CCIO}$  of this I/O type is 1.5V; when  $V_{REF}$  is  $V_{REF1\_LOAD}$ ,  $V_{CCIO}$  of this I/O type is 1.5V/1.8V/2.5V/3.3V.
- <sup>[4]</sup> When  $V_{REF}$  is INTERNAL,  $V_{CCIO}$  of this I/O type is 1.8V; when  $V_{REF}$  is  $V_{REF1\_LOAD}$ ,  $V_{CCIO}$  of this I/O type is 1.8V/2.5V/3.3V.
- <sup>[5]</sup> When  $V_{REF}$  is INTERNAL,  $V_{CCIO}$  of this I/O type is 2.5V; when  $V_{REF}$  is  $V_{REF1\_LOAD}$ ,  $V_{CCIO}$  of this I/O type is 2.5V/3.3V.

## 2.3.2 True LVDS Design

The GW1N series of FPGA products (except GW1N-1/GW1N-1S) support true LVDS output. In addition, the GW1N series of FPGA products support LVDS25E, MLVDS25E, BLVDS25E, etc.

For more information about true LVDS, see [UG174, GW1N-1P5 Pinout](#), [UG171, GW1N-2 Pinout](#), [UG105, GW1N-4 Pinout](#), and [UG114, GW1N-9 Pinout](#).

True LVDS input needs a 100Ω termination resistor, see Figure 2-12 for the reference design. Specific banks of the GW1N series of FPGA products support programmable on-chip 100Ω input differential termination resistors, see [UG289, Gowin Programmable IO User Guide](#).

Figure 2-12 True LVDS Design

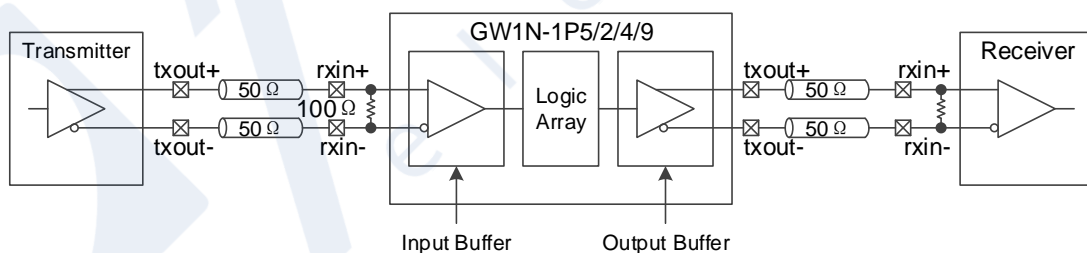

For information about termination for LVDS25E, MLVDS25E, and BLVDS25E, please refer to [UG289, Gowin Programmable IO User Guide](#).

## 2.3.3 I/O Logic

Figure 2-13 shows the I/O logic input and output of the GW1N series

of FPGA products.

Figure 2-13 I/O Logic Input and Output

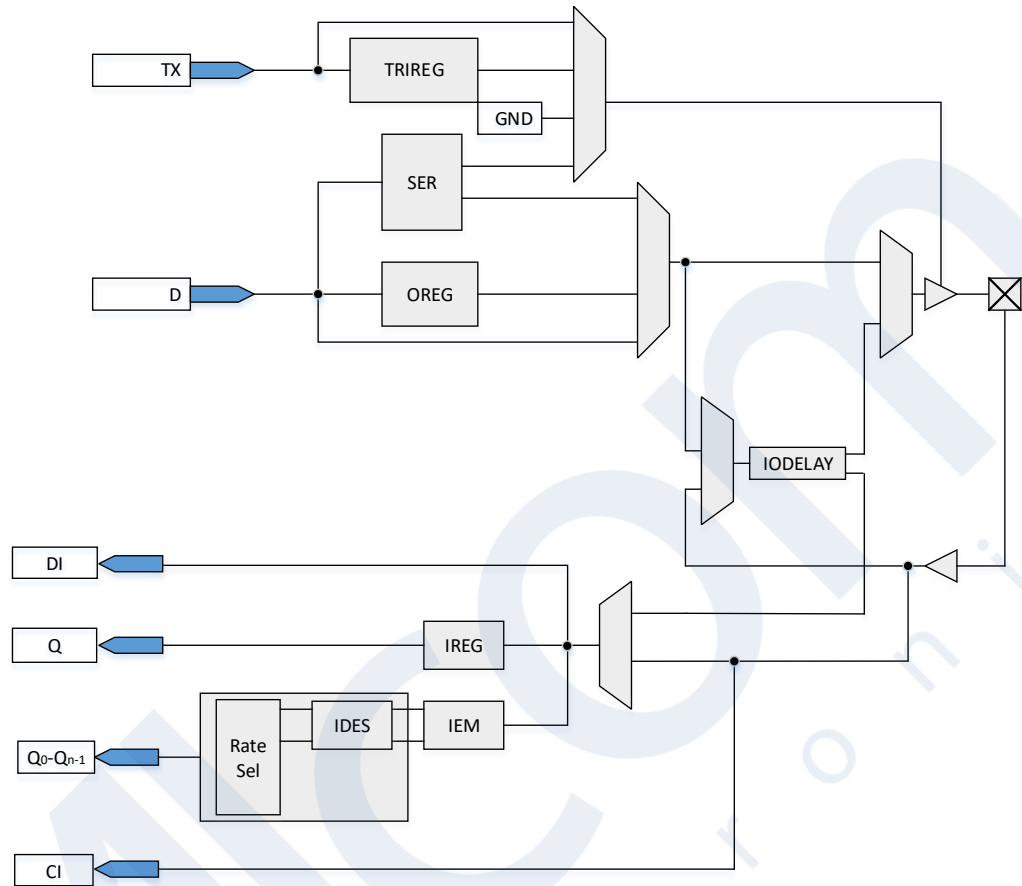

Table 2-3 Port Description

Port	I/O	Description
C <sup>[1]</sup>	Input	GCLK input signal. For the number of GCLK input signals, please refer to <a href="#">UG107, GW1N-1 Pinout</a> , <a href="#">UG169, GW1N-1S Pinout</a> , <a href="#">UG171, GW1N-2 Pinout</a> , <a href="#">UG174, GW1N-1P5 Pinout</a> , <a href="#">UG105, GW1N-4 Pinout</a> , and <a href="#">UG114, GW1N-9 Pinout</a> .
DI	Input	IO port low-speed input signal input into the fabric directly.
Q	Output	IREG output signal in the SDR module.
Q <sub>0</sub> -Q <sub>n-1</sub>	Output	IDES output signal in the DDR module.

**Note!**

When CI is used as GCLK input, DI, Q, and Q<sub>0</sub>-Q<sub>n-1</sub> cannot be used as I/O input and output.

Descriptions of the I/O logic modules of the GW1N series of FPGA products are presented below.

## IODELAY

See Figure 2-14 for an overview of the IODELAY module. Each I/O of the GW1N series of FPGA products has an IODELAY module, providing a total of 128(0~127) steps of delay, with one step of delay time being about 30 ps.

Figure 2-14 IODELAY Diagram

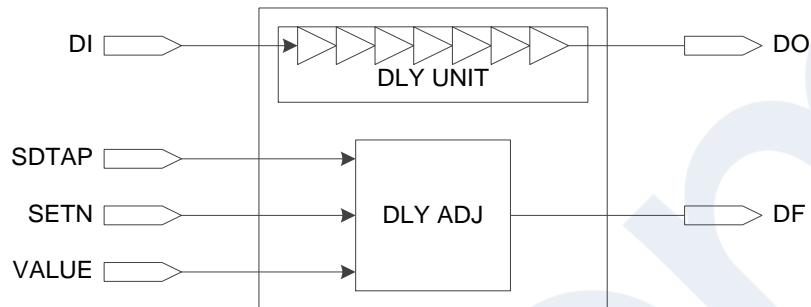

There are two ways to control the delay:

- Static control.
- Dynamic control: can be used with the IEM module to adjust the dynamic sampling window. The IODELAY module cannot be used for both input and output at the same time

## I/O Register

See Figure 2-15 for the I/O register in the GW1N series of FPGA products. Each I/O provides one input register (IREG), one output register (OREG), and one tristate register (TRIREG).

Figure 2-15 I/O Register Diagram

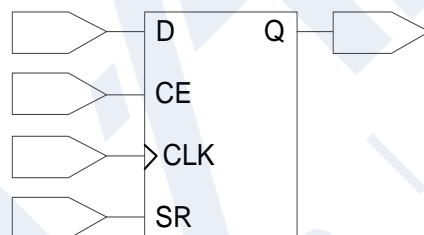

### Note!

- CE can be programmed as either active low (0: enable) or active high (1: enable).
- CLK can be programmed as either rising edge triggering or falling edge triggering.
- SR can be programmed as either synchronous/asynchronous SET/RESET or disabled.
- The register can be programmed as a register or a latch.

## IEM

The IEM(Input Edge Monitor) module is used to sample data edges and is used in generic DDR mode, as shown in Figure 2-16.

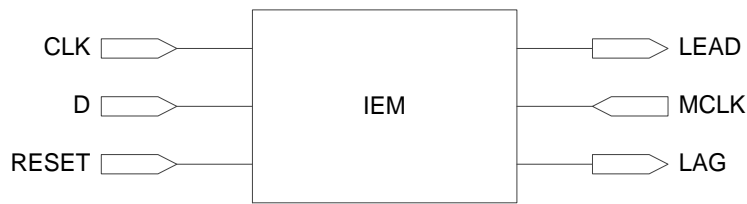
**Figure 2-16 IEM Diagram****DES**

The GW1N series of FPGA products provide a simple deserializer(DES) for input I/O logic to support advanced I/O protocols.

**SER**

The GW1N series of FPGA products provide a simple serializer(SER) for output I/O logic to support advanced I/O protocols.

**2.3.4 I/O Logic Modes**

The I/O Logic of the GW1N series of FPGA products supports several operation modes. In each operation mode, the I/O (or I/O differential pair) can be configured as output, input, INOUT or tristate output (output signal with tristate control).

All pins of GW1N-1S and GW1N-9 support I/O logic. The pins of GW1N-1(except IOL6(A, B,C....J) and IOR6(A,B,C....J)) support IO logic. The pins of GW1N-4(except IOL10(A, B,C....J) and IOR10(A,B,C....J)) support IO logic. The pins of GW1N-1P5/GW1N-2(except IOT2(A, B), IOT3A) support IO logic.

**2.4 Block SRAM****2.4.1 Introduction**

The GW1N series of FPGA products provide abundant block SRAM resources. These memory resources are distributed as blocks throughout the FPGA array in the form of rows. Therefore, they are called block static random access memories (BSRAMs). The capacity of each BSRAM can be up to 18,432 bits (18 Kbits). There are four operation modes: Single Port mode, Dual Port mode, Semi-Dual Port mode, and ROM mode.

An abundance of BSRAM resources provide a guarantee for the user's high-performance design. The features of BSRAMs include:

- Up to 18,432 bits per BSRAM
- Clock frequency up to 190MHz
- Supports Single Port mode
- Supports Dual Port mode
- Supports Semi-Dual Port mode
- Provides parity bits
- Supports ROM Mode

- Data widths from 1 to 36 bits
- Mixed clock mode
- Mixed data width mode
- Byte Enable function for 2-byte and above data widths
- Normal read and write
- Read-before-write
- Write-through

## 2.4.2 Memory Configuration Modes

BSRAMs in the GW1N series of FPGA products support various data widths, see Table 2-4.

Table 2-4 Memory Size Configuration

Single Port Mode	Dual Port Mode <sup>[1]</sup>	Semi-Dual Port Mode	ROM Mode <sup>[2]</sup>
16K x 1	16K x 1	16K x 1	16K x 1
8K x 2	8K x 2	8K x 2	8K x 2
4K x 4	4K x 4	4K x 4	4K x 4
2K x 8	2K x 8	2K x 8	2K x 8
1K x 16	1K x 16	1K x 16	1K x 16
512 x 32	-	512 x 32	512 x 32
2K x 9	2K x 9	2K x 9	2K x 9
1K x 18	1K x 18	1K x 18	1K x 18
512 x 36	-	512 x 36	512 x 36

### Note!

- <sup>[1]</sup> GW1N-1S does not support dual port mode; For the GW1N-9 devices, only the C version supports dual port mode.
- <sup>[2]</sup> For the GW1N-4 devices, only the D version supports ROM mode.

### Single Port Mode

The single port mode supports 2 read modes (bypass mode and pipeline mode) and 3 write modes (normal mode, write-through mode, and read-before-write mode). In single port mode, writing to or reading from one port at one clock edge is supported. During the write operation, the written data will be transferred to the output of the BSRAM. When the output register is bypassed, the new data will show up at the same write clock rising edge.

For more information on single port mode, please refer to [UG285, Gowin BSRAM & SSRAM User Guide](#).

### Dual Port Mode

The dual port mode supports 2 read modes (bypass mode and

pipeline mode) and 2 write modes (normal mode and write-through mode). The applicable operations are as follows:

- Two independent read operations
- Two independent write operations
- An independent read operation and an independent write operation

**Note!**

It is not recommended to perform simultaneous read access from one port and write access from the other port to the same memory address.

For more information on dual port mode, please refer to [UG285, Gowin BSRAM & SSRAM User Guide](#).

### Semi-Dual Port Mode

The semi-dual port mode supports 2 read modes (bypass mode and pipeline mode) and 1 write mode (normal mode). Semi-dual port mode supports simultaneous read and write operations in the form of writing to port A and reading from port B.

**Note!**

It is not recommended to perform simultaneous read access from one port and write access from the other port to the same memory address.

For more information on semi-dual port mode, please refer to [UG285, Gowin BSRAM & SSRAM User Guide](#).

### ROM Mode

BSRAMs can be configured as ROMs. The ROM can be initialized during the device configuration stage, and the ROM data needs to be provided in the initialization file. Initialization is completed during the device power-on process.

Each BSRAM can be configured as one 16 Kbit ROM. For more information on ROM mode, please refer to [UG285, Gowin BSRAM & SSRAM User Guide](#).

## 2.4.3 Mixed Data Width Configuration

The BSRAMs in the GW1N series of FPGA products support mixed data width operations. In dual port and semi-dual port mode, the data widths for read and write can be different, see Table 2-5 and Table 2-6.

Table 2-5 Dual Port Mixed Read/Write Data Width Configuration<sup>[1],[2]</sup>

Read Port	Write Port						
	16K x 1	8K x 2	4K x 4	2K x 8	1K x 16	2K x 9	1K x 18
16K x 1	*	*	*	*	*		
8K x 2	*	*	*	*	*		
4K x 4	*	*	*	*	*		
2K x 8	*	*	*	*	*		

Read Port	Write Port						
	16K x 1	8K x 2	4K x 4	2K x 8	1K x 16	2K x 9	1K x 18
1K x 16	*	*	*	*	*		
2K x 9						*	*
1K x 18						*	*

**Note!**

- <sup>[1]</sup> GW1N-1S does not support dual port mode; For the GW1N-9 devices, only the C version supports dual port mode.
- <sup>[2]</sup> "\*" denotes the modes supported.

**Table 2-6 Semi-dual Port Mixed Read/Write Data Width Configuration**

Read Port	Write Port								
	16K x 1	8K x 2	4K x 4	2K x 8	1K x 16	512 x 32	2K x 9	1K x 18	512 x 36
16K x 1	*	*	*	*	*	*			
8K x 2	*	*	*	*	*	*			
4K x 4	*	*	*	*	*	*			
2K x 8	*	*	*	*	*	*			
1K x 16	*	*	*	*	*	*			
512x32	*	*	*	*	*	*			
2K x 9							*	*	*
1K x 18							*	*	*

**Note!**

"\*" denotes the modes supported.

## 2.4.4 Byte-enable

BSRAMs support the byte-enable function. For data longer than a byte, the additional bits can be blocked, allowing only the selected portion to be written into the memory. The blocked bits will be retained for future operation. Read/write enable ports (WREA, WREB) and byte-enable parameter options can be used to control the BSRAM write operation.

**Note!**

For the GW1N series, only GW1N-1P5, GW1N-1P5B, GW1N-1P5C, GW1N-2, GW1N-2B, GW1N-2C, and GW1N-4D support the byte-enable function.

## 2.4.5 Parity Bit

There are parity bits in BSRAMs. The 9th bit in each byte can be used as a parity bit to check the correctness of data transmission. It can also be used for data storage.

## 2.4.6 Synchronous Operation

- All the input registers of BSRAMs support synchronous write.

- The output registers can be used as pipeline registers to improve design performance.
- The output registers are bypass-able.

### 2.4.7 BSRAM Operation Modes

The BSRAM supports five different operations, including two read modes (Bypass Mode and Pipeline Mode) and three write modes (Normal Mode, Write-Through Mode, and Read-before-Write Mode).

#### Read Mode

The following two read modes are supported.

##### PIPELINE MODE

When a synchronous write cycles into a memory array with pipeline registers enabled, the data can be read from pipeline registers in the next clock cycle. The data bus can be up to 36 bits in this mode.

##### BYPASS MODE

When a synchronous write cycles into a memory array with pipeline registers bypassed, the outputs are registered at the memory array.

**Figure 2-17 Pipeline Mode in Single Port Mode, Dual Port Mode, and Semi-dual Port Mode**

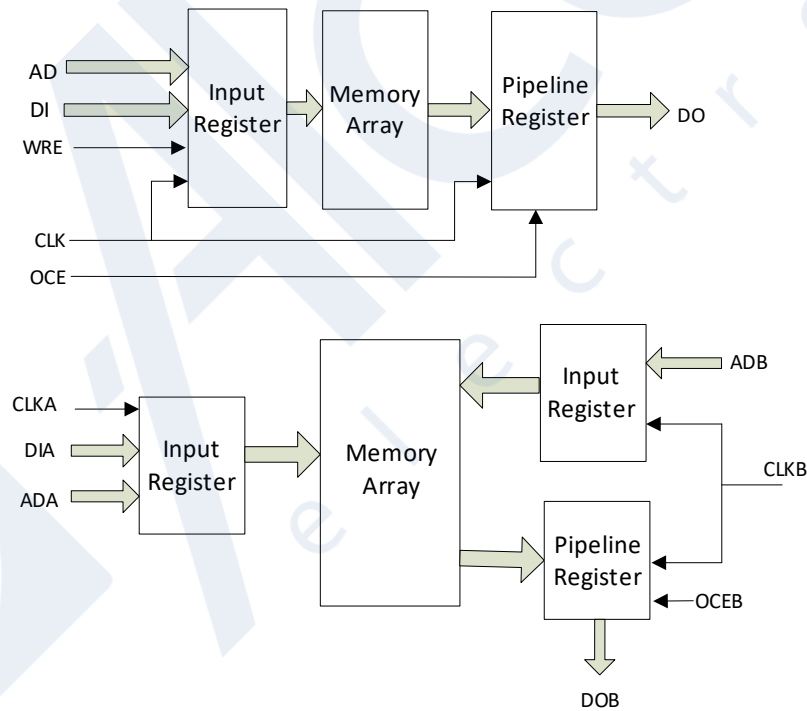



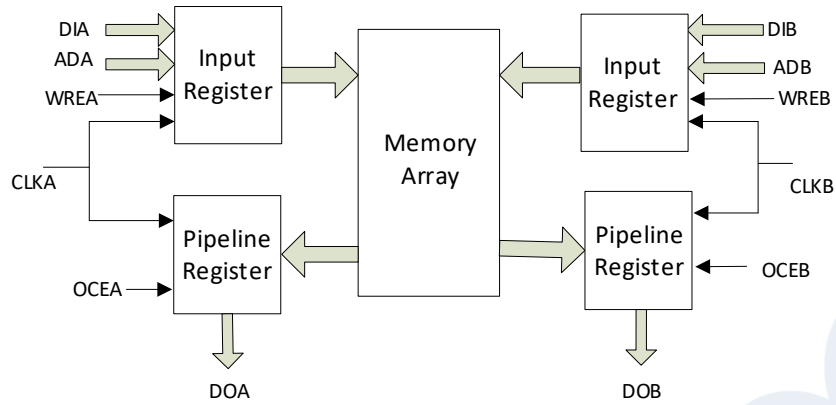

**Write Mode**

**NORMAL WRITE MODE**

In this mode, when you write data to one port, the output data of this port does not change. The written data will not appear at the read port.

**WRITE-THROUGH MODE**

In this mode, when you write data to one port, the written data will appear at the output of this port.

**READ-BEFORE-WRITE MODE**

In this mode, when you write data to one port, the written data will be stored in the memory according to the address, and the original data in this address will appear at the output of this port.

**2.4.8 Clock Mode**

Table 2-7 lists the clock modes in different BSRAM modes:

**Table 2-7 Clock Modes in Different BSRAM Modes**

Clock Mode	Dual Port Mode <sup>[1]</sup>	Semi-Dual Port Mode	Single Port Mode
Independent Clock Mode	Yes	No	No
Read/Write Clock Mode	Yes	Yes	No
Single Port Clock Mode	No	No	Yes

**Note!**

<sup>[1]</sup> GW1N-1S does not support dual port mode.

**Independent Clock Mode**

Figure 2-18 shows the independent clock operation in dual port mode with one clock at each port. CLKA controls all the registers at Port A; CLKB controls all the registers at Port B.

**Figure 2-18 Independent Clock Mode**

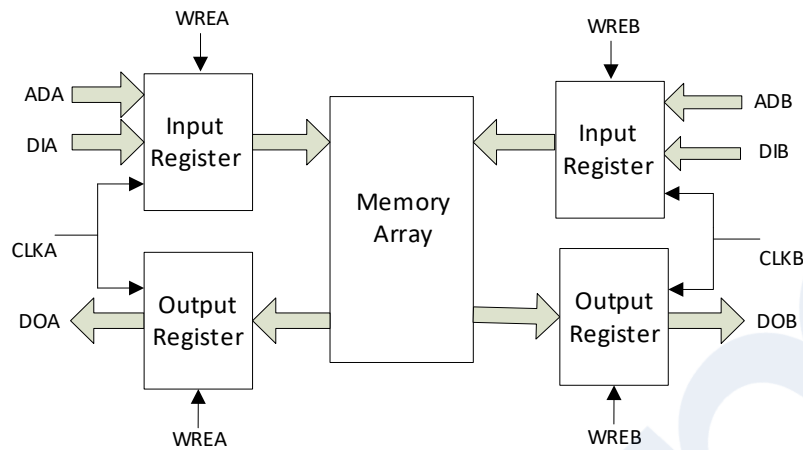

**Read/Write Clock Mode**

Figure 2-19 shows the read/write clock operation in semi-dual port mode with one clock at each port. The write clock (CLKA) controls data inputs, write addresses and read/write enable signals of Port A. The read clock (CLKB) controls data outputs, read addresses, and read enable signals of Port B.

**Figure 2-19 Read/Write Clock Mode**

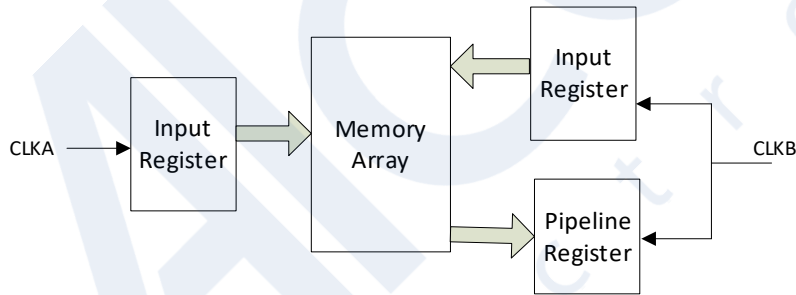

**Single Port Clock Mode**

Figure 2-20 shows the clock operation in single port mode.

**Figure 2-20 Single Port Clock Mode**

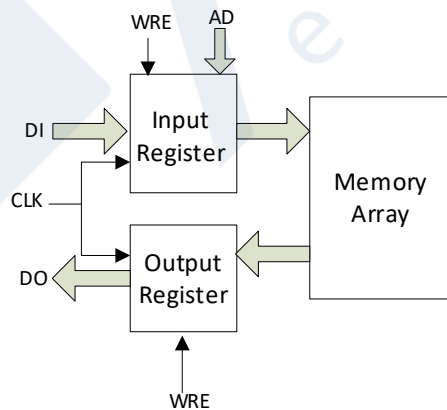

## 2.5 User Flash(GW1N-1/1S)

GW1N-1 and GW1N-1S provide a User Flash with 12 Kbytes (48 pages x 256 bytes). The key features include:

- NOR Flash
- 100,000 write cycles
- Greater than 10 years of data retention at +85°C
- Selectable input/output data widths of 8/16/32 bits
- Page size: 256 bytes
- Standby current: 3μA
- Page write time: 8.2ms

For more information about the User Flash in GW1N-1/1S, please refer to [UG295, Gowin User Flash User Guide](#). For the correspondence between User Flash primitives and devices supported, please refer to Table 3-1 Devices Supported of [UG295, Gowin User Flash User Guide](#).

## 2.6 User Flash(GW1N-1P5/2/4/9)

GW1N-1P5/2/4/9 provide a User Flash. The capacity of the User Flash in GW1N-1P5/2 is 96 Kbits. The capacity of the User Flash in GW1N-4 is 256 Kbits. The capacity of the User Flash in GW1N-9 is 608 Kbits. The User Flash consists of row memories and column memories. One row memory consists of 64 column memories. The capacity of one column memory is 32 bits, and the capacity of one row memory is  $64 \times 32 = 2048$  bits. Page erase is supported, and the capacity of one page is 2048 bytes, that is, one page contains 8 rows. The key features include:

- NOR Flash
- 10,000 write cycles
- Greater than 10 years of data retention at +85°C
- Data width: 32 bits
- Capacity in GW1N-1P5/2 : 48 rows x 64 columns x 32 = 96 Kbits
- Capacity in GW1N-4 : 128 rows x 64 columns x 32 = 256 Kbits
- Capacity in GW1N-9 : 304 rows x 64 columns x 32 = 608 Kbits
- Page erase capability: 2,048 bytes per page
- Fast Page Erase/Word Program Operation
- Clock frequency: 40 MHz
- Word Programming Time:  $\leq 16\mu\text{s}$
- Page Erase Time:  $\leq 120\text{ms}$
- Current
  - Read current/duration: 2.19mA/25ns ( $V_{CC}$ ) & 0.5mA/25ns ( $V_{CCX}$ )(MAX)
  - Program/erase operation: 12/12mA(MAX)

For more information about the User Flash in GW1N-1P5/2/4/9,

please refer to [UG295, Gowin User Flash User Guide](#). For the correspondence between User Flash primitives and devices supported, please refer to Table 3-1 Devices Supported of [UG295, Gowin User Flash User Guide](#).

## 2.7 Digital Signal Processing

GW1N-4/9 provide abundant DSP resources. Gowin's DSP solutions can address high-performance digital signal processing needs such as FIR and FFT designs. The DSP resources have the advantages of stable timing performance, high resource utilization, and low power consumption.

The DSP resources offer the following functions:

- Multipliers with three widths: 9-bit, 18-bit, 36-bit
- 54-bit ALU
- Multipliers cascading to support wider data widths
- Barrel shifters
- Adaptive filtering through signal feedback
- Computing with options to round to a positive number or a prime number
- Supports pipeline mode and bypass mode.

### 2.7.1 Macro

The DSP blocks are distributed throughout the FPGA array in the form of rows. Each DSP block occupies 9 CFU locations. Each DSP block contains two macros, and each macro contains two pre-adders, two 18 x 18 bit multipliers, and one three-input ALU.

#### Pre-adder

Each DSP macro contains two pre-adders for implementing pre-addition, pre-subtraction, and shifting.

The pre-adders are located at the first stage with two input ports:

- Parallel 18-bit input B or SIB
- Parallel 18-bit input A or SIA

#### Note!

Each input port supports pipeline mode and bypass mode.

Gowin's pre-adders can be used independently as function blocks, which support 9-bit and 18-bit width.

#### Multiplier

The multipliers are located after the pre-adders. The multipliers can be configured as 9 x 9, 18 x 18, 36 x 18, or 36 x 36. Register mode and bypass mode are supported in both input and output ports. The configuration modes that a macro supports include:

- One 18 x 36 multiplier

- Two 18 x 18 multipliers
- Four 9 x 9 multipliers

**Note!**

Two macros can form one 36 x 36 multiplier

**Arithmetic Logic Unit**

Each DSP macro contains one 54-bit ALU, which can further enhance multipliers' functions. Register mode and bypass mode are supported in both input and output ports. The functions include:

- Addition/subtraction operations of multiplier output data/0, data A, and data B.
- Addition/subtraction operations of multiplier output data/0, data B, and carry C.
- Addition/subtraction operations of data A, data B, and carry C.

**2.7.2 DSP Operation Modes**

- Multiplier mode
- Multiply accumulator mode
- Multiply-add accumulator mode

For more information on the DSP resources, see [UG287, Gowin Digital Signal Processing \(DSP\) User Guide](#).

**2.8 MIPI D-PHY****2.8.1 Hard MIPI D-PHY RX core(GW1N-2)**

GW1N-2 provides a hard MIPI D-PHY RX core that supports the “MIPI Alliance Standard for D-PHY Specification(Version 2.1)”. The dedicated D-PHY core supports MIPI DSI and CSI-2 mobile video interfaces for cameras and displays. The key features include:

- High Speed RX at up to 8Gbps per quad(four data lanes)
- Supports up to 4 data lanes and 1 clock lane
- Supports bidirectional low-power (LP) mode at up to 10Mbps per lane
- Supports built-in HS Sync, bit and lane alignment
- Supports MIPI D-PHY RX 1:8 and 1:16 deserialization modes
- Supports MIPI DSI and MIPI CSI-2 link layers
- Available on Bank6

For more information, see [IPUG778, Gowin GW1N-2 Hardened MIPI D-PHY RX User Guide](#).

**2.8.2 GPIOs support MIPI D-PHY RX/TX**

The GPIOs support MIPI IO mode. MIPI D-PHY RX/TX implemented by using MIPI IO mode supports MIPI DSI and CSI-2 interfaces for cameras and displays in both transmit and receive modes. The support for MIPI IO mode in the GW1N series of FPGA products is shown in the table

below.

**Table 2-8 List of GW1N series of FPGA Products that Support MIPI IO Mode**

MIPI Input/Output	GW1N-1S	GW1N-1P5	GW1N-2	GW1N-9
MIPI Input	Bank0/1	Bank2(with dynamic ODT)	Bank2(with dynamic ODT)	Bank0(with dynamic ODT)
MIPI Output	None	Bank0/3/4/5(with dynamic ODT)	Bank0/3/4/5(with dynamic ODT)	Bank2

The key features include:

- MIPI Alliance Standard for D-PHY Specification, Version 1.2
- High Speed RX and TX at up to 4.8Gbps
- Supports up to 4 data lanes and 1 clock lane
- Supports multiple PHYs(if there are enough IOs available)
- Supports bidirectional low-power (LP) mode
- Supports MIPI DSI and MIPI CSI-2 link layers
- Supports built-in HS Sync, bit and lane alignment
- Supports MIPI D-PHY RX 1:8 and 1:16 deserialization modes
- Supports multiple IO Types: ELVDS, TLVDS, SLVS200, LVDS, and MIPI D-PHY IO
- Bank0/2 of GW1N-9 support I3C

For more information, see [IPUG948, Gowin MIPI D-PHY RX TX Advance User Guide](#).

## 2.9 Clocks

The clock resources and wiring are critical for high-performance applications in FPGA. The GW1N series of FPGA products provide global clocks (GCLKs) which connect to all the registers directly. In addition, high-speed clocks (HCLKs), PLLs, etc. are provided.

For more information on the GCLKs, HCLKs, PLLs, see [UG286, Gowin Clock User Guide](#).

### 2.9.1 Global Clocks

The Global Clock(GCLK) resources are distributed in the device as quadrants. Each quadrant provides eight GCLKs. The clock sources of GCLKs include dedicated clock input pins and CRUs, and better clock performance can be achieved by using the dedicated clock input pins.

### 2.9.2 PLLs

The PLL (Phase-locked Loop) is one kind of feedback control circuit. The frequency and phase of the internal oscillator signal are controlled by

the external input reference clock.

PLLs in the GW1N series of FPGA products can provide synthesizable clock frequencies. Frequency adjustment (multiplication and division), phase adjustment, and duty cycle adjustment can be achieved by configuring the parameters.

### 2.9.3 High-speed Clocks

The high-speed clocks (HCLKs) can support high-performance data transfer of I/Os and are mainly suitable for source synchronous data transfer protocols, see Figure 2-21 - Figure 2-25.

**Note!**

GW1N-1 and GW1N-4 have the same HCLK features, and GW1N-1S and GW1N-9 have the same HCLK features.

**Figure 2-21 GW1N-1 HCLK Distribution**

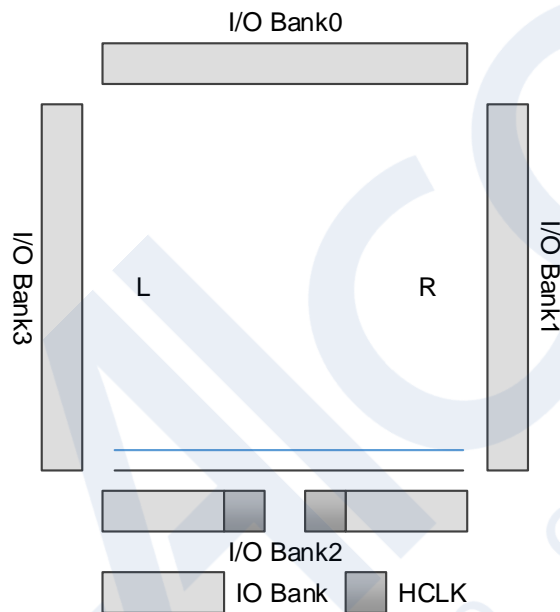

Figure 2-22 GW1N-1P5/2 HCLK Distribution

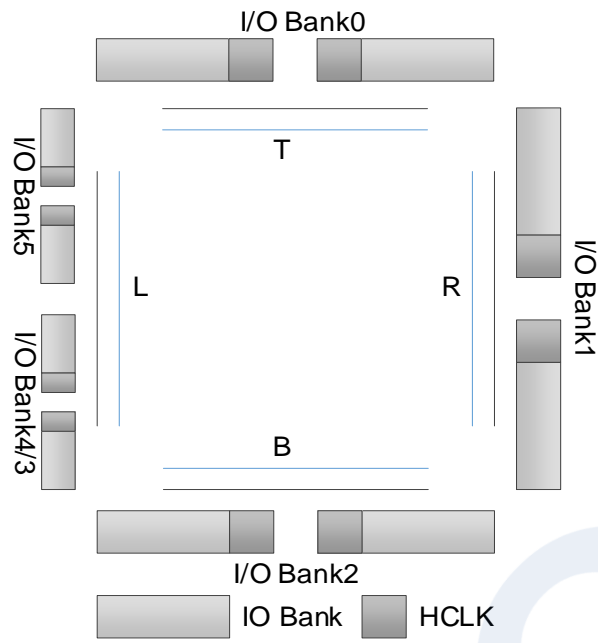

Figure 2-23 GW1N-4 HCLK Distribution

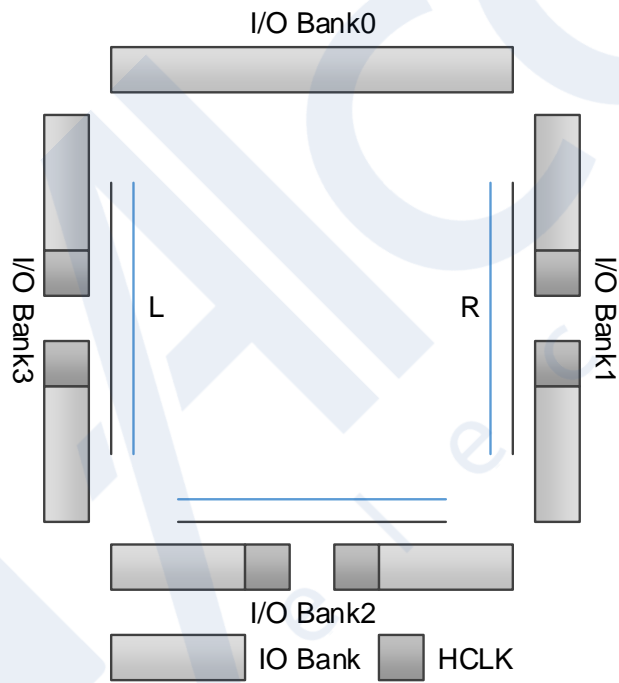



Figure 2-24 GW1N-9 HCLK Distribution

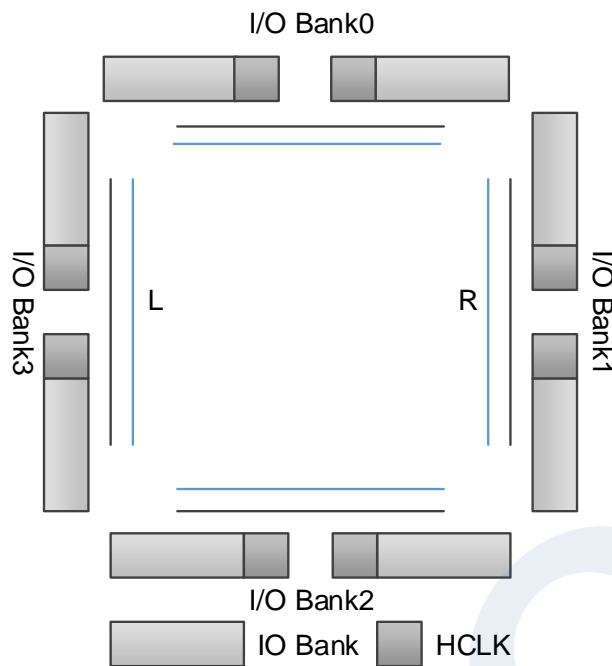
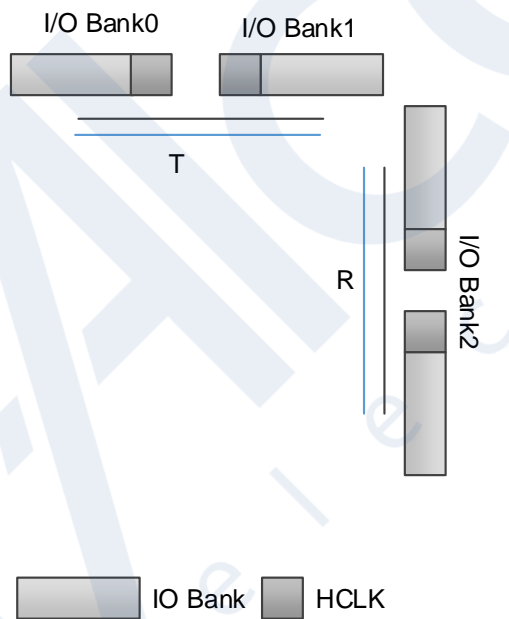

Figure 2-25 GW1N-1S HCLK Distribution



## 2.10 Long Wires

As a supplement to the CRU, the GW1N series of FPGA products provide another kind of routing resource - the long wire, which can be used for clock, clock enable, set/reset, or other high fan out signals.

## 2.11 Global Set/Reset

The GW1N series of FPGA products offer a dedicated global set/reset (GSR) network that connects directly to the device's internal logic and can be used as asynchronous/synchronous set or asynchronous/synchronous reset, with the registers in the CFUs and I/Os being able to be configured

independently.

## 2.12 Programming & Configuration

The GW1N series of FPGA products support SRAM configuration and Flash programming. Flash programming includes on-chip Flash programming and off-chip Flash programming. The GW1N series of FPGA products support DUAL BOOT, allowing you to back up data to the off-chip Flash as needed.

Besides JTAG, the GW1N series of FPGA products also support Gowin's own GowinCONFIG configuration mode: AUTO BOOT, SSPI, MSPI, DUAL BOOT, SERIAL, CPU, and I2C Slave. All the devices support JTAG and AUTO BOOT.

For more information, please refer to [UG290, Gowin FPGA Products Programming and Configuration User Guide](#).

### SRAM Configuration

If SRAM configuration is used, the configuration data needs to be re-downloaded upon each power-up.

### Flash programming

The Flash programming data is stored in the on-chip Flash. Each time the device is powered up, the configuration data is transferred from the Flash to the SRAM. Configuration can be completed within a few milliseconds after power-up, which is also known as "instant on".

The GW1N series of FPGA products (except the GW1N-4 A version) support the feature of background upgrade. That is to say, you can program the on-chip Flash or off-chip Flash via the JTAG<sup>[1]</sup> interface without affecting the current working state. During programming, the device works according to the previous configuration. After the programming is completed, trigger RECONFIG\_N with a low level to complete the upgrade. This feature is suitable for the applications requiring long online time and irregular upgrades.

#### Note!

- <sup>[1]</sup> GW1N-1P5 and GW1N-2 can support the I<sup>2</sup>C background upgrade by using the goConfig I2C IP. It is recommended to use the JTAG interface to implement the background upgrade.
- <sup>[2]</sup> As a configuration pin, RECONFIG\_N is an input pin with internal weak pull-up, but as a GPIO, RECONFIG\_N can only be used for output. For more information, please refer to [UG290, Gowin FPGA Products Programming and Configuration User Guide](#).

In addition, the GW1N series of FPGA products support off-chip Flash programming and DUAL BOOT. For more information, please refer to [UG290, Gowin FPGA Products Programming and Configuration User Guide](#).

## 2.13 On-chip Oscillator

The GW1N series of FPGA products have an embedded

programmable on-chip clock oscillator that supports clock frequencies ranging from 2.5 MHz to 105MHz. It provides a MSPI clock source for the MSPI configuration mode with a tolerance of  $\pm 5\%$ .

The on-chip oscillator also provides a clock resource for user designs. Up to 64 clock frequencies can be obtained by setting the parameters.

The following formula is used to get the output clock frequency of the on-chip oscillator of GW1N-1/1S:

$$f_{\text{out}}=240\text{MHz}/\text{Param.}$$

The following formula is used to get the output clock frequency of the on-chip oscillator of GW1N-1P5/2/9:

$$f_{\text{out}}=250\text{MHz}/\text{Param.}$$

The following formula is used to get the output clock frequency of the on-chip oscillator of GW1N-4:

$$f_{\text{out}}=210\text{MHz}/\text{Param.}$$

**Note!**

“Param” should be even numbers from 2 to 128.

Table 2-9, Table 2-10, and Table 2-11 list some frequencies provided by the on-chip crystal oscillator.

**Table 2-9 Output Frequency Options of the On-chip Oscillator of GW1N-4**

Mode	Frequency	Mode	Frequency	Mode	Frequency
0	2.1MHz <sup>[1]</sup>	8	6.6MHz	16	13.1MHz
1	4.6MHz	9	7MHz	17	15MHz
2	4.8MHz	10	7.5MHz	18	17.5MHz
3	5MHz	11	8.1MHz	19	21MHz
4	5.3MHz	12	8.8MHz	20	26.3MHz
5	5.5MHz	13	9.5MHz	21	35MHz
6	5.8MHz	14	10.5MHz	22	52.5MHz
7	6.2MHz	15	11.7MHz	23	105MHz <sup>[2]</sup>

**Table 2-10 Output Frequency Options of the On-chip Oscillator of GW1N-1P5/2/9**

Mode	Frequency	Mode	Frequency	Mode	Frequency
0	2.5MHz <sup>[1]</sup>	8	7.8MHz	16	15.6MHz
1	5.4MHz	9	8.3MHz	17	17.9MHz
2	5.7MHz	10	8.9MHz	18	21MHz
3	6.0MHz	11	9.6MHz	19	25MHz
4	6.3MHz	12	10.4MHz	20	31.3MHz
5	6.6MHz	13	11.4MHz	21	41.7MHz

Mode	Frequency	Mode	Frequency	Mode	Frequency
6	6.9MHz	14	12.5MHz	22	62.5MHz
7	7.4MHz	15	13.9MHz	23	125MHz <sup>[2]</sup>

**Table 2-11 Output Frequency Options of the On-chip Oscillator of GW1N-1/1S**

Mode	Frequency	Mode	Frequency	Mode	Frequency
0	2.4MHz <sup>[1]</sup>	8	7.5MHz	16	15MHz
1	5.2MHz	9	8MHz	17	17MHz
2	5.5MHz	10	8.6MHz	18	20MHz
3	5.7MHz	11	9MHz	19	24MHz
4	6MHz	12	10MHz	20	20MHz
5	6.3MHz	13	11MHz	21	40MHz
6	6.7MHz	14	12MHz	22	60MHz
7	7MHz	15	13MHz	23	120MHz <sup>[2]</sup>

**Note!**

- <sup>[1]</sup> Default frequency.
- <sup>[2]</sup> This is not available for the MSPI configuration mode.

# 3 AC/DC Characteristics

## Note!

Please ensure that you use Gowin's devices within the recommended operating conditions and ranges. Data beyond the working conditions and ranges are for reference only. Gowin does not guarantee that all devices will operate normally beyond the operating conditions and ranges.

## 3.1 Operating Conditions

### 3.1.1 Absolute Max. Ratings

Table 3-1 Absolute Max. Ratings

Name	Description	Min.	Max.
V <sub>CC</sub>	Core voltage(LV version)	-0.5V	1.32V
	Core voltage(UV version)	-0.5V	3.75V
V <sub>CCIO</sub>	I/O Bank voltage	-0.5V	3.75V
V <sub>CCX</sub>	Auxiliary voltage	-0.5V	3.75V
V <sub>CCD</sub>	Hard-core MIPI D-PHY core voltage(GW1N-2)	-0.5V	1.32V
V <sub>CCIOD</sub>	Hard-core MIPI D-PHY I/O voltage(GW1N-2)	-0.5V	1.32V
-	I/O voltage applied <sup>[1]</sup>	-0.5V	3.75V
Storage Temperature	Storage Temperature	-65°C	+150°C
Junction Temperature	Junction Temperature	-40°C	+125°C

## Note!

<sup>[1]</sup> Overshoot and undershoot of -2V to (V<sub>IHMAX</sub> + 2)V are allowed for a duration of <20 ns.

### 3.1.2 Recommended Operating Conditions

Table 3-2 Recommended Operating Conditions

Name	Description	Min.	Max.
V <sub>CC</sub>	Core voltage(LV version)	1.14V	1.26V

Name	Description	Min.	Max.
	Core voltage(UV version)	1.71V	3.6V
V <sub>CCIO</sub>	I/O Bank voltage	1.14V	3.6V
V <sub>CCX</sub>	Auxiliary voltage(GW1N-4/9)	2.375V	3.6V
	Auxiliary voltage(GW1N-1P5/2)	1.71V	3.6V
V <sub>CCD</sub>	Hard-core MIPI D-PHY core voltage(GW1N-2)	1.14V	1.26V
V <sub>CCIOD</sub>	Hard-core MIPI D-PHY I/O voltage(GW1N-2)	1.14V	1.26V
T <sub>JCOM</sub>	Junction temperature for commercial operations	0°C	+85°C
T <sub>JIND</sub>	Junction temperature for industrial operations	-40°C	+100°C

**Note!**

- For some packages, V<sub>CCIO</sub> and V<sub>CCX</sub> may share the same pin. In this case, V<sub>CCX</sub> requirements must be met first.
- The allowable ripples on V<sub>CC</sub>, V<sub>CCIO</sub>, and V<sub>CCX</sub> are 3%, 5%, and 5% respectively. For devices of which the PLL is powered directly with V<sub>CC</sub>, the ripple on V<sub>CC</sub> can affect the jitter characteristics of the PLL output clock; 2). The ripple on V<sub>CCIO</sub> can eventually be passed on to the output waveform of the IO Buffer.
- For more information on the power supplies, please refer to [UG107, GW1N-1 Pinout](#), [UG169, GW1N-1S Pinout](#), [UG171, GW1N-2 Pinout](#), [UG174, GW1N-1P5 Pinout](#), [UG105, GW1N-4 Pinout](#), and [UG114, GW1N-9 Pinout](#).

### 3.1.3 Power Supply Ramp Rates

Table 3-3 Power Supply Ramp Rates

Name	Description	Device	Min.	Typ.	Max.
V <sub>CC</sub> Ramp	Power supply ramp rates for V <sub>CC</sub>	GW1N-1/GW1N-1S	1.2mV/μs	-	40mV/μs
		GW1N- 1P5/2/4/9	0.6mV/μs	-	6mV/μs
V <sub>CCX</sub> Ramp	Power supply ramp rates for V <sub>CCX</sub>	GW1N	0.6mV/μs	-	10mV/us
V <sub>CCIO</sub> Ramp	Power supply ramp rates for V <sub>CCIO</sub>	GW1N	0.1mV/μs	-	10mV/us

**Note!**

- A monotonic ramp is required for all power supplies.
- All power supplies need to be in the operating range as defined in Table 3-2 before configuration. Power supplies that are not in the operating range need to be adjusted to a faster ramp rate, or you have to delay configuration.

### 3.1.4 Hot Socketing Specifications

Table 3-4 Hot Socketing Specifications

Name	Description	Condition	I/O Type	Max.
I <sub>HS</sub>	Input or I/O leakage current	$0 < V_{IN} < V_{IH}(MAX)$	I/O	150uA
I <sub>HS</sub>	Input or I/O leakage current	$0 < V_{IN} < V_{IH}(MAX)$	TDI, TDO, TMS, TCK	120uA

### 3.1.5 POR Specifications

Table 3-5 POR Parameters

Name	Description	Device	Name	Value
V <sub>POR_UP</sub>	Power on reset ramp up trip point	GW1N-1	V <sub>CC</sub>	0.75V
			V <sub>CCIO</sub>	0.85V
		GW1N-1P5, GW1N-2	V <sub>CC</sub>	0.8V
			V <sub>CCX</sub>	1.5V
			V <sub>CCIO</sub>	0.95V
		GW1N-4	V <sub>CC</sub>	0.95V
			V <sub>CCX</sub>	1.95V
			V <sub>CCIO</sub>	0.95V
		GW1N-9	V <sub>CC</sub>	0.95V
			V <sub>CCX</sub>	1.95V
			V <sub>CCIO</sub>	0.95V
		V <sub>POR_DOWN</sub>	Power on reset ramp down trip point	GW1N-1
V <sub>CCIO</sub>	TBD			
GW1N-1P5, GW1N-2	V <sub>CC</sub>			0.65V
	V <sub>CCX</sub>			1.3V
	V <sub>CCIO</sub>			0.75V
GW1N-4	V <sub>CC</sub>			0.75V
	V <sub>CCX</sub>			1.8V
	V <sub>CCIO</sub>			0.6V
GW1N-9	V <sub>CC</sub>			0.75V
	V <sub>CCX</sub>			1.8V
	V <sub>CCIO</sub>			0.6V

## 3.2 ESD performance

Table 3-6 GW1N ESD - HBM

Device	GW1N-1	GW1N-1P5	GW1N-2	GW1N-4	GW1N-9	GW1N-1S
LQ100	-	HBM>1,000 V	HBM>1,000 V	HBM>1,000 V	HBM>1,000 V	-
LQ100X	-	HBM>1,000 V	HBM>1,000 V	-	-	-
LQ144	-	-	-	HBM>1,000 V	HBM>1,000 V	-
LQ144X	-	-	HBM>1,000 V	-	-	-
LQ144F	-	-	HBM>1,000 V	-	-	-
EQ144	-	-	HBM>1,000 V	HBM>1,000 V	HBM>1,000 V	-
LQ176	-	-	-	-	HBM>1,000 V	-
EQ176	-	-	-	-	HBM>1,000 V	-
MG100	-	-	-	-	HBM>1,000 V	-
MG100T	-	-	-	-	HBM>1,000 V	-
MG49	-	-	HBM>1,000 V	-	-	-
MG121	-	-	HBM>1,000 V	-	-	-
MG121X	-	-	HBM>1,000 V	-	-	-
MG132	-	-	HBM>1,000 V	-	-	-
MG132X	-	-	HBM>1,000 V	HBM>1,000 V	-	-
MG132H	-	-	HBM>1,000 V	-	-	-
MG160	-	-	-	HBM>1,000 V	HBM>1,000 V	-
MG196	-	-	-	-	HBM>1,000 V	-
PG256	-	-	-	HBM>1,000 V	HBM>1,000 V	-



Device	GW1N-1	GW1N-1P5	GW1N-2	GW1N-4	GW1N-9	GW1N-1S
PG256M	-	-	-	HBM>1,000 V	-	-
UG169	-	-	-	HBM>1,000 V	HBM>1,000 V	-
UG256	-	-	-	-	HBM>1,000 V	-
UG332	-	-	-	-	HBM>1,000 V	-
QN32X	-	-	HBM>1,000 V	-	-	-
QN32	-	-	HBM>1,000 V	HBM>1,000 V	-	-
QN48	-	-	HBM>1,000 V	HBM>1,000 V	HBM>1,000 V	-
QN48H	-	-	HBM>1,000 V	-	-	-
QN48F	-	-	-	-	HBM>1,000 V	-
QN48X	-	HBM>1,000 V	-	-	-	-
QN48XF	-	HBM>1,000 V	-	-	-	-
CS30	HBM>1,000 V	-	-	-	-	-
CS42	-	-	HBM>1,000 V	-	-	-
CS42H	-	-	HBM>1,000 V	-	-	-
CS72	-	-	-	HBM>1,000 V	-	-
CS81M	-	-	-	-	HBM>1,000 V	-
CS100H	-	-	HBM>1,000 V	-	-	-
QN88	-	-	HBM>1,000 V	HBM>1,000 V	HBM>1,000 V	-
FN32	-	-	-	-	-	-

Table 3-7 GW1N ESD - CDM

Device	GW1N-1	GW1N-1P5	GW1N-2	GW1N-4	GW1N-9	GW1N-1S
LQ100	-	-	CDM>500V	CDM>500V	CDM>500V	-
LQ100X	-	CDM>500V	CDM>500V	-	-	-
LQ144	-	-	CDM>500V	CDM>500V	CDM>500V	-
LQ144X	-	-	CDM>500V	-	-	-
LQ144F	-	-	CDM>500V	-	-	-
EQ144	-	-	-	CDM>500V	CDM>500V	-
LQ176	-	-	-	-	CDM>500V	-
EQ176	-	-	-	-	CDM>500V	-
MG49	-	-	CDM>500V	-	-	-
MG100	-	-	-	-	CDM>500V	-
MG121	-	-	CDM>500V	-	-	-
MG121X	-	-	CDM>500V	-	-	-
MG132	-	-	CDM>500V	-	-	-
MG132X	-	-	CDM>500V	CDM>500V	-	-
MG132H	-	-	CDM>500V	-	-	-
MG160	-	-	-	CDM>500V	CDM>500V	-
MG196	-	-	-	-	CDM>500V	-
MG100T	-	-	-	-	-	-
PG256	-	-	-	CDM>500V	CDM>500V	-
PG256M	-	-	-	CDM>500V	-	-
UG169	-	-	-	CDM>500V	CDM>500V	-
UG256	-	-	-	-	CDM>500V	-
UG332	-	-	-	-	CDM>500V	-
QN32	-	-	CDM>500V	CDM>500V	-	-
QN32X	-	-	CDM>500V	-	-	-
QN48	-	-	CDM>500V	CDM>500V	CDM>500V	-
QN48H	-	-	CDM>500V	-	-	-
QN48F	-	-	-	-	CDM>500V	-
QN48X	-	CDM>500V	-	-	-	-
QN48XF	-	CDM>500V	-	-	-	-
CS30	CDM>500V	-	-	-	-	-

Device	GW1N-1	GW1N-1P5	GW1N-2	GW1N-4	GW1N-9	GW1N-1S
CS42	-	-	CDM>500V	-	-	-
CS42H	-	-	CDM>500V	-	-	-
CS72	-	-	-	CDM>500V	-	-
CS81M	-	-	-	-	CDM>500V	-
CS100H	-	-	CDM>500V	-	-	-
QN88	-	-	CDM>500V	CDM>500V	CDM>500V	-
FN32	-	-	-	-	-	-

## 3.3 DC Characteristics

### 3.3.1 DC Electrical Characteristics over Recommended Operating Conditions

Table 3-8 DC Electrical Characteristics over Recommended Operating Conditions

Name	Description	Condition	Min.	Typ.	Max.
I <sub>IL</sub> , I <sub>IH</sub>	Input or I/O leakage	V <sub>CCIO</sub> < V <sub>IN</sub> < V <sub>IH</sub> (MAX)	-	-	210μA
		0 < V <sub>IN</sub> < V <sub>CCIO</sub>	-	-	10μA
I <sub>PU</sub>	I/O Active Pull-up Current(I/O Active Pull-up Current)	0 < V <sub>IN</sub> < 0.7V <sub>CCIO</sub>	-30μA	-	-150μA
I <sub>PD</sub>	I/O Active Pull-down Current(I/O Active Pull-down Current)	V <sub>IL</sub> (MAX) < V <sub>IN</sub> < V <sub>CCIO</sub>	30μA	-	150μA
I <sub>BHLS</sub>	Bus Hold Low Sustaining Current(Bus Hold Low Sustaining Current)	V <sub>IN</sub> = V <sub>IL</sub> (MAX)	30μA	-	-
I <sub>BHHS</sub>	Bus Hold High Sustaining Current(Bus Hold High Sustaining Current)	V <sub>IN</sub> = 0.7V <sub>CCIO</sub>	-30μA	-	-
I <sub>BHLO</sub>	Bus Hold Low Overdrive Current(Bus Hold Low Overdrive Current)	0 ≤ V <sub>IN</sub> ≤ V <sub>CCIO</sub>	-	-	150μA
I <sub>BHHO</sub>	Bus Hold High Overdrive Current	0 ≤ V <sub>IN</sub> ≤ V <sub>CCIO</sub>	-	-	-150μA

Name	Description	Condition	Min.	Typ.	Max.
V <sub>BHT</sub>	Bus Hold Trip Points		V <sub>IL</sub> (MAX)	-	V <sub>IH</sub> (MIN)
C1	I/O Capacitance(I/O Capacitance)			5pF	8pF
V <sub>HYST</sub>	Hysteresis for Schmitt Trigger inputs	V <sub>CCIO</sub> =3.3V, Hysteresis=L2H <sup>[1],[2]</sup>	-	200mV	-
		V <sub>CCIO</sub> =2.5V, Hysteresis= L2H	-	125mV	-
		V <sub>CCIO</sub> =1.8V, Hysteresis= L2H	-	60mV	-
		V <sub>CCIO</sub> =1.5V, Hysteresis= L2H	-	40mV	-
		V <sub>CCIO</sub> =1.2V, Hysteresis= L2H	-	20mV	-
		V <sub>CCIO</sub> =3.3V, Hysteresis= H2L <sup>[1],[2]</sup>	-	200mV	-
		V <sub>CCIO</sub> =2.5V, Hysteresis= H2L	-	125mV	-
		V <sub>CCIO</sub> =1.8V, Hysteresis= H2L	-	60mV	-
		V <sub>CCIO</sub> =1.5V, Hysteresis= H2L	-	40mV	-
		V <sub>CCIO</sub> =1.2V, Hysteresis= H2L	-	20mV	-
		V <sub>CCIO</sub> =3.3V, Hysteresis= HIGH <sup>[1],[2]</sup>	-	400mV	-
		V <sub>CCIO</sub> =2.5V, Hysteresis= HIGH	-	250mV	-
		V <sub>CCIO</sub> =1.8V, Hysteresis= HIGH	-	120mV	-
		V <sub>CCIO</sub> =1.5V, Hysteresis= HIGH	-	80mV	-
V <sub>CCIO</sub> =1.2V, Hysteresis= HIGH	-	40mV	-		

**Note!**

- <sup>[1]</sup> Hysteresis="NONE", "L2H", "H2L", "HIGH" indicates the Hysteresis options that can be set when setting I/O Constraints in the FloorPlanner tool of Gowin EDA, for more details, see [SUG935, Gowin Design Physical Constraints User Guide](#).
- <sup>[2]</sup> Enabling the L2H (low to high) option means raising V<sub>IH</sub> by V<sub>HYST</sub>; enabling the H2L (high to low) option means lowering V<sub>IL</sub> by V<sub>HYST</sub>; enabling the HIGH option means enabling both L2H and H2L options, i.e. V<sub>HYST</sub>(HIGH) = V<sub>HYST</sub>(L2H) + V<sub>HYST</sub>(H2L). The diagram is shown below.

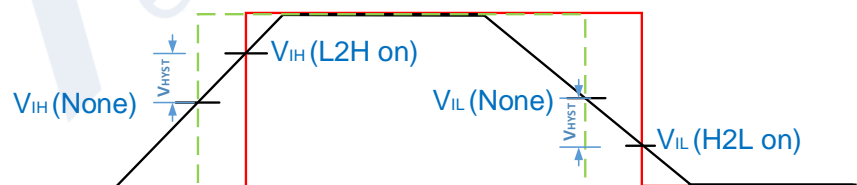

### 3.3.2 Static Current

Table 3-9 Static Current

Device	Name	Description	Device type	C7/I6	C6/I5	C5/I4	Unit
GW1N-1	I <sub>CC</sub>	V <sub>CC</sub> current (V <sub>CC</sub> =1.2V)	LV	2.5	1.8	1.5	mA

Device	Name	Description	Device type	C7/I6	C6/I5	C5/I4	Unit
	I <sub>CCIO</sub>	V <sub>CCIO</sub> current (V <sub>CCIO</sub> =2.5V)	LV	1	0.8	0.6	mA
GW1N-2	I <sub>CC + I<sub>CCX</sub></sub>	V <sub>CCX</sub> current and V <sub>CC</sub> current (V <sub>CCX</sub> =V <sub>CC</sub> =3.3V)	UV	15	12	10	mA
	I <sub>CCIO</sub>	V <sub>CCIO</sub> current (V <sub>CCIO</sub> =2.5V)	UV	1.2	1	0.8	mA
	I <sub>CC</sub>	V <sub>CC</sub> current (V <sub>CC</sub> =1.2V)	LV	3	2.5	2.2	mA
	I <sub>CCX</sub>	V <sub>CCX</sub> current (V <sub>CCX</sub> =3.3V)	LV	1.5	0.75	0.6	mA
	I <sub>CCIO</sub>	V <sub>CCIO</sub> current (V <sub>CCIO</sub> =2.5V)	LV	0.6	0.5	0.4	mA
GW1N-1P5	I <sub>CC + I<sub>CCX</sub></sub>	V <sub>CCX</sub> current and V <sub>CC</sub> current (V <sub>CCX</sub> =V <sub>CC</sub> =3.3V)	UV	15	12	10	mA
	I <sub>CCIO</sub>	V <sub>CCIO</sub> current (V <sub>CCIO</sub> =2.5V)	UV	1.2	1	0.8	mA
	I <sub>CC</sub>	V <sub>CC</sub> current (V <sub>CC</sub> =1.2V)	LV	3	2.5	2.2	mA
	I <sub>CCX</sub>	V <sub>CCX</sub> current (V <sub>CCX</sub> =3.3V)	LV	1.5	0.75	0.6	mA
	I <sub>CCIO</sub>	V <sub>CCIO</sub> current (V <sub>CCIO</sub> =2.5V)	LV	0.6	0.5	0.4	mA
GW1N-4	I <sub>CC</sub>	V <sub>CC</sub> current (V <sub>CC</sub> =1.2V)	LV	3.4	2.8	2.4	mA
	I <sub>CC</sub>	V <sub>CC</sub> current (V <sub>CC</sub> =3.3V)	UV	20	18	16	mA
	I <sub>CCX</sub>	V <sub>CCX</sub> current (V <sub>CCX</sub> =3.3V)	LV/UV	1.4	0.9	0.7	mA
	I <sub>CCIO</sub>	V <sub>CCIO</sub> current (V <sub>CCIO</sub> =2.5V)	LV/UV	0.7	0.55	0.4	mA
GW1N-9	I <sub>CC</sub>	V <sub>CC</sub> current (V <sub>CC</sub> =1.2V)	LV	2.8	2.4	2	mA
	I <sub>CC</sub>	V <sub>CC</sub> current (V <sub>CC</sub> =3.3V)	UV	20	18	16	mA
	I <sub>CCX</sub>	V <sub>CCX</sub> current (V <sub>CCX</sub> =3.3V)	LV/UV	1.5	1.3	1	mA
	I <sub>CCIO</sub>	V <sub>CCIO</sub> current (V <sub>CCIO</sub> =2.5V)	LV/UV	0.9	0.7	0.5	mA

**Note!**

The values in Table 3-9 are typical values at 25°C.

### 3.3.3 Programming Current

Table 3-10 Programming Current

Device	Description	Device type	Max.(mA)
GW1N-1	V <sub>CC</sub> current when programming the Flash (V <sub>CC</sub> =1.2V)	LV	4.8
	V <sub>CCIO</sub> current when programming the Flash (V <sub>CCIO</sub> =2.5V)	LV	2.8
GW1N-2	V <sub>CC</sub> current when programming the Flash (V <sub>CC</sub> =1.2V)	LV	2.19
	V <sub>CCX</sub> current when programming the Flash (V <sub>CC</sub> =3.3V)	LV	12
	V <sub>CCIO</sub> current when programming the Flash (V <sub>CCIO</sub> =2.5V)	LV	2
GW1N-1P5	V <sub>CC</sub> current when programming the Flash (V <sub>CC</sub> =1.2V)	LV	2.19
	V <sub>CCX</sub> current when programming the Flash (V <sub>CC</sub> =3.3V)	LV	12
	V <sub>CCIO</sub> current when programming the Flash (V <sub>CCIO</sub> =2.5V)	LV	2

Device	Description	Device type	Max.(mA)
GW1N-4	V <sub>CC</sub> current when programming the Flash (V <sub>CC</sub> =1.2V)	LV	2.19
	V <sub>CCX</sub> current when programming the Flash (V <sub>CC</sub> =3.3V)	LV	12
	V <sub>CCIO</sub> current when programming the Flash (V <sub>CCIO</sub> =2.5V)	LV	2
GW1N-9	V <sub>CC</sub> current when programming the Flash (V <sub>CC</sub> =1.2V)	LV	2.19
	V <sub>CCX</sub> current when programming the Flash (V <sub>CC</sub> =3.3V)	LV	12
	V <sub>CCIO</sub> current when programming the Flash (V <sub>CCIO</sub> =2.5V)	LV	2

**Note!**

The current values in Table 3-10 are the maximum programming currents at room temperature under normal atmospheric pressure.

### 3.3.4 Recommended I/O Operating Conditions

Table 3-11 Recommended I/O Operating Conditions

Name	V <sub>CCIO</sub> (V) for Output			V <sub>REF</sub> (V) for Input		
	Min.	Typ.	Max.	Min.	Typ.	Max.
LVTTL33	3.135	3.3	3.6	-	-	-
LVC MOS33	3.135	3.3	3.6	-	-	-
LVC MOS25	2.375	2.5	2.625	-	-	-
LVC MOS18	1.71	1.8	1.89	-	-	-
LVC MOS15	1.425	1.5	1.575	-	-	-
LVC MOS12	1.14	1.2	1.26	-	-	-
SSTL15	1.425	1.5	1.575	0.68	0.75	0.9
SSTL18_I	1.71	1.8	1.89	0.833	0.9	0.969
SSTL18_II	1.71	1.8	1.89	0.833	0.9	0.969
SSTL25_I	2.375	2.5	2.645	1.15	1.25	1.35
SSTL25_II	2.375	2.5	2.645	1.15	1.25	1.35
SSTL33_I	3.135	3.3	3.6	1.3	1.5	1.7
SSTL33_II	3.135	3.3	3.6	1.3	1.5	1.7
HSTL18_I	1.71	1.8	1.89	0.816	0.9	1.08
HSTL18_II	1.71	1.8	1.89	0.816	0.9	1.08
HSTL15	1.425	1.5	1.575	0.68	0.75	0.9
PCI33	3.135	3.3	3.6	-	-	-
LVPECL33E	3.135	3.3	3.6	-	-	-

Name	V <sub>CCIO</sub> (V) for Output			V <sub>REF</sub> (V) for Input		
	Min.	Typ.	Max.	Min.	Typ.	Max.
MLVDS25E	2.375	2.5	2.625	-	-	-
BLVDS25E	2.375	2.5	2.625	-	-	-
RSDS25E	2.375	2.5	2.625	-	-	-
LVDS25E	2.375	2.5	2.625	-	-	-
SSTL15D	1.425	1.5	1.575	-	-	-
SSTL18D_I	1.71	1.8	1.89	-	-	-
SSTL18D_II	1.71	1.8	1.89	-	-	-
SSTL25D_I	2.375	2.5	2.625	-	-	-
SSTL25D_II	2.375	2.5	2.625	-	-	-
SSTL33D_I	3.135	3.3	3.6	-	-	-
SSTL33D_II	3.135	3.3	3.6	-	-	-
HSTL15D	1.425	1.5	1.575	-	-	-
HSTL18D_I	1.71	1.8	1.89	-	-	-
HSTL18D_II	1.71	1.8	1.89	-	-	-

### 3.3.5 Single-ended I/O DC Characteristics

Table 3-12 Single-ended I/O DC Characteristics

Name	V <sub>IL</sub>		V <sub>IH</sub>		V <sub>OL</sub> (Max)	V <sub>OH</sub> (Min)	I <sub>OL</sub> <sup>[1]</sup> (mA)	I <sub>OH</sub> <sup>[1]</sup> (mA)
	Min	Max	Min	Max				
LVCMOS33 LVTTTL33	-0.3V	0.8V	2.0V	3.6V	0.4V	V <sub>CCIO</sub> -0.4V	4	-4
							8	-8
							12	-12
							16	-16
							24 <sup>[2]</sup>	-24 <sup>[2]</sup>
					0.2V	V <sub>CCIO</sub> -0.2V	0.1	-0.1
LVCMOS25	-0.3V	0.7V	1.7V	3.6V	0.4V	V <sub>CCIO</sub> -0.4V	4	-4
							8	-8
							12	-12
							16	-16
LVCMOS18	-0.3V	0.35*V <sub>CCIO</sub>	0.65*V <sub>CCIO</sub>	3.6V	0.4V	V <sub>CCIO</sub> -0.4V	4	-4
							8	-8

Name	$V_{IL}$		$V_{IH}$		$V_{OL}$ (Max)	$V_{OH}$ (Min)	$I_{OL}^{[1]}$ (mA)	$I_{OH}^{[1]}$ (mA)
	Min	Max	Min	Max				
							12	-12
					0.2V	$V_{CCIO}-0.2V$	0.1	-0.1
LVCMOS15	-0.3V	$0.35 \cdot V_{CCIO}$	$0.65 \cdot V_{CCIO}$	3.6V	0.4V	$V_{CCIO}-0.4V$	4	-4
							8	-8
					0.2V	$V_{CCIO}-0.2V$	0.1	-0.1
LVCMOS12	-0.3V	$0.35 \cdot V_{CCIO}$	$0.65 \cdot V_{CCIO}$	3.6V	0.4V	$V_{CCIO}-0.4V$	2	-2
							6	-6
					0.2V	$V_{CCIO}-0.2V$	0.1	-0.1
PCI33	-0.3V	$0.3 \cdot V_{CCIO}$	$0.5 \cdot V_{CCIO}$	3.6V	$0.1 \cdot V_{CCIO}$	$0.9 \cdot V_{CCIO}$	1.5	-0.5
SSTL33_I	-0.3V	$V_{REF}-0.2V$	$V_{REF}+0.2V$	3.6V	0.7	$V_{CCIO}-1.1V$	8	-8
SSTL25_I	-0.3V	$V_{REF}-0.18V$	$V_{REF}+0.18V$	3.6V	0.54V	$V_{CCIO}-0.62V$	8	-8
SSTL25_II	-0.3V	$V_{REF}-0.18V$	$V_{REF}+0.18V$	3.6V	NA	NA	NA	NA
SSTL18_II	-0.3V	$V_{REF}-0.125V$	$V_{REF}+0.125V$	3.6V	NA	NA	NA	NA
SSTL18_I	-0.3V	$V_{REF}-0.125V$	$V_{REF}+0.125V$	3.6V	0.40V	$V_{CCIO}-0.40V$	8	-8
SSTL15	-0.3V	$V_{REF}-0.1V$	$V_{REF}+0.1V$	3.6V	0.40V	$V_{CCIO}-0.40V$	8	-8
HSTL18_I	-0.3V	$V_{REF}-0.1V$	$V_{REF}+0.1V$	3.6V	0.40V	$V_{CCIO}-0.40V$	8	-8
HSTL18_II	-0.3V	$V_{REF}-0.1V$	$V_{REF}+0.1V$	3.6V	NA	NA	NA	NA
HSTL15_I	-0.3V	$V_{REF}-0.1V$	$V_{REF}+0.1V$	3.6V	0.40V	$V_{CCIO}-0.40V$	8	-8
HSTL15_II	-0.3V	$V_{REF}-0.1V$	$V_{REF}+0.1V$	3.6V	NA	NA	NA	NA

**Note!**

- <sup>[1]</sup> The total DC current limit(sourced and sunk current) of all IOs in the same bank: the total DC current of all IOs in the same bank shall not be greater than  $n \cdot 8mA$ , where n represents the number of IOs bonded out from a bank.
- <sup>[2]</sup> GW1N-1P5 and GW1N-2 do not support 24mA.

### 3.3.6 Differential I/O DC Characteristics

Table 3-13 Differential I/O DC Characteristics

Name	Description	Test conditions	Min.	Typ.	Max.	Unit
$V_{INA}, V_{INB}$	Input Voltage		0	-	2.15	V
$V_{CM}$	Input Common Mode Voltage(Input Common Mode Voltage)	Half the Sum of the Two Inputs	0.05	-	2.1	V
$V_{THD}$	Differential Input Threshold	Difference Between the Two Inputs	$\pm 100$	-	$\pm 600$	mV



Name	Description	Test conditions	Min.	Typ.	Max.	Unit
I <sub>IN</sub>	Input Current	Power On or Power Off	-	-	±20	µA
V <sub>OH</sub>	Output High Voltage for V <sub>OP</sub> or V <sub>OM</sub>	R <sub>T</sub> = 100Ω	-	-	1.60	V
V <sub>OL</sub>	Output Low Voltage for V <sub>OP</sub> or V <sub>OM</sub>	R <sub>T</sub> = 100Ω	0.9	-	-	V
V <sub>OD</sub>	Output Voltage Differential	(V <sub>OP</sub> - V <sub>OM</sub> ), R <sub>T</sub> =100Ω	250	350	450	mV
ΔV <sub>OD</sub>	Change in V <sub>OD</sub> Between High and Low		-	-	50	mV
V <sub>OS</sub>	Output Voltage Offset	(V <sub>OP</sub> + V <sub>OM</sub> )/2, R <sub>T</sub> =100Ω	1.125	1.20	1.375	V
ΔV <sub>OS</sub>	Change in V <sub>OS</sub> Between High and Low		-	-	50	mV
I <sub>S</sub>	Short-circuit current	V <sub>OD</sub> = 0V output short-circuit	-	-	15	mA

## 3.4 Switching Characteristics

### 3.4.1 CFU Switching Characteristics

Table 3-14 CFU Internal Timing Parameters<sup>[1], [2]</sup>

Device	Name	Description	C7/I6		C6/I5		C5/I4		Unit
			Min	Max	Min	Max	Min	Max	
GW1N-1	t <sub>LUT4_CFU</sub>	LUT4 delay	0.412	0.594	0.556	0.802	0.695	1.002	ns
	t <sub>SR_CFU</sub>	Set/Reset to Register output	0.648	1.268	0.875	1.712	1.094	2.140	ns
	t <sub>CO_CFU</sub>	Clock to Register output	0.247	0.340	0.333	0.458	0.417	0.573	ns
GW1N-2/GW1N-1P5	t <sub>LUT4_CFU</sub>	LUT4 delay	0.412	0.594	0.556	0.802	0.695	1.002	ns
	t <sub>SR_CFU</sub>	Set/Reset to Register output	0.648	1.268	0.875	1.712	1.094	2.140	ns
	t <sub>CO_CFU</sub>	Clock to Register output	0.247	0.340	0.333	0.458	0.417	0.573	ns
GW1N-4	t <sub>LUT4_CFU</sub>	LUT4 delay	0.412	0.594	0.556	0.802	0.695	1.002	ns
	t <sub>SR_CFU</sub>	Set/Reset to Register output	0.648	1.268	0.875	1.712	1.094	2.140	ns
	t <sub>CO_CFU</sub>	Clock to Register output	0.247	0.340	0.333	0.458	0.417	0.573	ns
GW1N-9	t <sub>LUT4_CFU</sub>	LUT4 delay	0.412	0.594	0.556	0.802	0.695	1.002	ns

Device	Name	Description	C7/I6		C6/I5		C5/I4		Unit
			Min	Max	Min	Max	Min	Max	
	t <sub>SR_CFU</sub>	Set/Reset to Register output	0.648	1.268	0.875	1.712	1.094	2.140	ns
	t <sub>CO_CFU</sub>	Clock to Register output	0.247	0.340	0.333	0.458	0.417	0.573	ns
GW1N-1S	t <sub>LUT4_CFU</sub>	LUT4 delay	0.412	0.594	0.556	0.802	0.695	1.002	ns
	t <sub>SR_CFU</sub>	Set/Reset to Register output	0.648	1.268	0.875	1.712	1.094	2.140	ns
	t <sub>CO_CFU</sub>	Clock to Register output	0.247	0.340	0.333	0.458	0.417	0.573	ns

**Note!**

- <sup>[1]</sup> The min/max values are based on the rising edge delay.
- <sup>[2]</sup> The LUT4 delay values are based on the delay of input port I3->F.

### 3.4.2 BSRAM Switching Characteristics

Table 3-15 BSRAM Timing Parameters

Device	Name	Description	C7/I6		C6/I5		C5/I4		Unit
			Min	Max	Min	Max	Min	Max	
GW1N-1	t <sub>COAD_BSRAM</sub>	Clock to output time of read address/data	2.564	2.564	3.460	3.460	4.325	4.325	ns
	t <sub>COOR_BSRAM</sub>	Clock to output time of output register	0.613	0.613	0.827	0.827	1.034	1.034	ns
GW1N-2/ GW1N-1P5	t <sub>COAD_BSRAM</sub>	Clock to output time of read address/data	2.564	2.564	3.460	3.460	4.325	4.325	ns
	t <sub>COOR_BSRAM</sub>	Clock to output time of output register	0.613	0.613	0.827	0.827	1.034	1.034	ns
GW1N-4	t <sub>COAD_BSRAM</sub>	Clock to output time of read address/data	2.564	2.564	3.460	3.460	4.325	4.325	ns
	t <sub>COOR_BSRAM</sub>	Clock to output time of output register	0.613	0.613	0.827	0.827	1.034	1.034	ns
GW1N-9	t <sub>COAD_BSRAM</sub>	Clock to output time of read address/data	2.564	2.564	3.460	3.460	4.325	4.325	ns
	t <sub>COOR_BSRAM</sub>	Clock to output time of output register	0.613	0.613	0.827	0.827	1.034	1.034	ns

Device	Name	Description	C7/I6		C6/I5		C5/I4		Unit
			Min	Max	Min	Max	Min	Max	
GW1N-1S	t <sub>COAD_BSRAM</sub>	Clock to output time of read address/data	2.564	2.564	3.460	3.460	4.325	4.325	ns
	t <sub>COOR_BSRAM</sub>	Clock to output time of output register	0.613	0.613	0.827	0.827	1.034	1.034	ns

**Note!**

t<sub>COAD\_BSRAM</sub> values refer to the delays in bypass mode.

### 3.4.3 DSP Switching Characteristics

Table 3-16 DSP Timing Parameters

Device	Name	Description	C7/I6		C6/I5		C5/I4		Unit
			Min	Max	Min	Max	Min	Max	
GW1N-1	t <sub>COIR_DSP</sub>	Clock to output time of input register	0.219	0.239	0.295	0.318	0.369	0.398	ns
	t <sub>COPR_DSP</sub>	Clock to output time of pipeline register	0.063	0.075	0.085	0.101	0.106	0.127	ns
	t <sub>COOR_DSP</sub>	Clock to output time of output register	0.034	0.038	0.046	0.052	0.057	0.065	ns
GW1N-2/GW1N-1P5	t <sub>COIR_DSP</sub>	Clock to output time of input register	0.219	0.239	0.295	0.318	0.369	0.398	ns
	t <sub>COPR_DSP</sub>	Clock to output time of pipeline register	0.063	0.075	0.085	0.101	0.106	0.127	ns
	t <sub>COOR_DSP</sub>	Clock to output time of output register	0.034	0.038	0.046	0.052	0.057	0.065	ns
GW1N-4	t <sub>COIR_DSP</sub>	Clock to output time of input register	0.219	0.239	0.295	0.318	0.369	0.398	ns
	t <sub>COPR_DSP</sub>	Clock to output time of pipeline register	0.063	0.075	0.085	0.101	0.106	0.127	ns
	t <sub>COOR_DSP</sub>	Clock to output time of output register	0.034	0.038	0.046	0.052	0.057	0.065	ns
GW1N-9	t <sub>COIR_DSP</sub>	Clock to output time of input register	0.219	0.239	0.295	0.318	0.369	0.398	ns
	t <sub>COPR_DSP</sub>	Clock to output time of pipeline register	0.063	0.075	0.085	0.101	0.106	0.127	ns
	t <sub>COOR_DSP</sub>	Clock to output time of output register	0.034	0.038	0.046	0.052	0.057	0.065	ns
GW1N-1S	t <sub>COIR_DSP</sub>	Clock to output time of input register	0.219	0.239	0.295	0.318	0.369	0.398	ns

Device	Name	Description	C7/I6		C6/I5		C5/I4		Unit
			Min	Max	Min	Max	Min	Max	
	tCOPR_DSP	Clock to output time of pipeline register	0.06 3	0.07 5	0.08 5	0.10 1	0.10 6	0.12 7	ns
	tCOOR_DSP	Clock to output time of output register	0.03 4	0.03 8	0.04 6	0.05 2	0.05 7	0.06 5	ns

### 3.4.4 Gearbox Switching Characteristics

Table 3-17 Gearbox Timing Parameters

Device	Name	Description	C7/I6		C6/I5		C5/I4		Unit
			Min	Max	Min	Max	Min	Max	
GW1N-1/4/9	FMAXIDDR	1:2 Gearbox maximum input serial rate	-	600	-	550	-	500	Mbps
	FMAXIDES4	1:4 Gearbox maximum input serial rate	-	800	-	750	-	700	Mbps
	FMAXIDESx	1:8/1:10 Gearbox maximum input serial rate	-	1000	-	900	-	800	Mbps
	FMAXODDR	2:1 Gearbox maximum output serial rate	-	600	-	550	-	500	Mbps
	FMAXOSER4	4:1 Gearbox maximum output serial rate	-	800	-	750	-	700	Mbps
	FMAXOSERx	8:1/10:1 Gearbox maximum output serial rate	-	1000	-	900	-	800	Mbps
GW1N-1P5/2	FMAXIDDR	1:2 Gearbox maximum input serial rate	-	600	-	550	-	500	Mbps
	FMAXIDES4	1:4 Gearbox maximum input serial rate	-	900	-	800	-	700	Mbps
	FMAXIDESx	1:8/1:10/1:16 Gearbox maximum input serial rate	-	1200	-	1000	-	900	Mbps
	FMAXODDR	2:1 Gearbox maximum output serial rate	-	600	-	550	-	500	Mbps
	FMAXOSER4	4:1 Gearbox maximum output serial rate	-	900	-	800	-	700	Mbps
	FMAXOSERx	8:1/10:1/16:1 Gearbox maximum output serial rate	-	1200	-	1000	-	900	Mbps

**Note!**

- The LVDS IO speed can be up to 1Gbps, but note that for the 1:4 Gearbox and 1:2 Gearbox, the internal core may not be able to reach the corresponding speed.
- Drive Strength=3.5 mA.

Table 3-18 Single-ended IO Fmax

Name	Fmax	
	Min. Value(MHz)	
	Drive Strength = 4mA	Drive Strength > 4mA
LVTTL33	150	300
LVCMOS33	150	300
LVCMOS25	150	300
LVCMOS18	150	300
LVCMOS15	150	200
LVCMOS12	150	150

**Note!**

Test load = 30pF.

### 3.4.5 Clock and I/O Switching Characteristics

Table 3-19 External Switching Characteristics

Device	Name	C7/I6	C6/I5	C5/I4	Unit
		Typ.	Typ.	Typ.	
GW1N-1	HCLK Tree delay	1	1.2	1.4	ns
	PCLK Tree delay(GCLK0~5)	2.2	2.4	2.6	ns
	PCLK Tree delay(GCLK6~7)	2.4	2.7	2.9	ns
	Pin-LUT-Pin Delay	4	4.3	4.6	ns
GW1N-1P5	HCLK Tree delay	0.6	0.8	1.1	ns
	PCLK Tree delay(GCLK0~5)	1.8	2.1	2.4	ns
	PCLK Tree delay(GCLK6~7)	2.1	2.5	2.8	ns
	Pin-LUT-Pin Delay	2.5	3	3.5	ns
GW1N-2	HCLK Tree delay	0.6	0.8	1.1	ns
	PCLK Tree delay(GCLK0~5)	1.8	2.1	2.4	ns
	PCLK Tree delay(GCLK6~7)	2.1	2.5	2.8	ns
	Pin-LUT-Pin Delay	2.5	3	3.5	ns

Device	Name	C7/I6	C6/I5	C5/I4	Unit
		Typ.	Typ.	Typ.	
GW1N-4	HCLK Tree delay	0.8	1	1.2	ns
	PCLK Tree delay(GCLK0~5)	2	2.2	2.5	ns
	PCLK Tree delay(GCLK6~7)	2.2	2.5	2.8	ns
	Pin-LUT-Pin Delay	4	4.2	4.5	ns
GW1N-9	HCLK Tree delay	0.8	1	1.2	ns
	PCLK Tree delay(GCLK0~5)	2	2.2	2.5	ns
	PCLK Tree delay(GCLK6~7)	2.2	2.5	2.8	ns
	Pin-LUT-Pin Delay	4	4.2	4.5	ns
GW1N-1S	HCLK Tree delay	0.9	1.1	1.3	ns
	PCLK Tree delay(GCLK0~5)	2.1	2.4	2.6	ns
	PCLK Tree delay(GCLK6~7)	2.3	2.6	2.8	ns
	Pin-LUT-Pin Delay	4.1	4.3	4.6	ns

### 3.4.6 On-chip Oscillator Switching Characteristics

Table 3-20 On-chip Oscillator Parameters

Name	Description	Min.	Typ.	Max.	
f <sub>MAX</sub>	On-chip Oscillator Output Frequency (0 ~ +85°C)	GW1N-4	97.25MHz	105MHz	112.85MHz
		GW1N-1/1S	114MHz	120MHz	126MHz
		GW1N-1P5/2/9	118.75MHz	125MHz	131.25MHz
	On-chip Oscillator Output Frequency (-40 ~ +100°C)	GW1N-4	91.85MHz	105MHz	118.25MHz
		GW1N-1/1S	108MHz	120MHz	132MHz
		GW1N-1P5/2/9	112.5MHz	125MHz	137.5MHz
t <sub>DT</sub>	Output Clock Duty Cycle	43%	50%	57%	
t <sub>OPJIT</sub>	Output Clock Period Jitter	0.01UIPP	0.012UIPP	0.02UIPP	

### 3.4.7 PLL Switching Characteristics

Table 3-21 PLL Parameters

Device	Speed Grade	Name	Min.	Max.	Unit
GW1N-1	C7/I6	CLKIN	3	400	MHz
		PFD	3	400	MHz
		VCO	400	900	MHz
		CLKOUT	3.125	450	MHz
	C6/I5	CLKIN	3	400	MHz
		PFD	3	400	MHz
		VCO	400	900	MHz
		CLKOUT	3.125	450	MHz
	C5/I4	CLKIN	3	320	MHz
		PFD	3	320	MHz
		VCO	320	720	MHz
		CLKOUT	2.5	360	MHz
GW1N-1S	C7/I6	CLKIN	3	400	MHz
		PFD	3	400	MHz
		VCO	400	1200	MHz
		CLKOUT	3.125	600	MHz
	C6/I5	CLKIN	3	400	MHz
		PFD	3	400	MHz
		VCO	400	1200	MHz
		CLKOUT	3.125	600	MHz
	C5/I4	CLKIN	3	320	MHz
		PFD	3	320	MHz
		VCO	320	960	MHz
		CLKOUT	2.5	480	MHz
GW1N-4 GW1N-9	C7/I6	CLKIN	3	400	MHz
		PFD	3	400	MHz
		VCO	400	1000	MHz
		CLKOUT	3.125	500	MHz
	C6/I5	CLKIN	3	400	MHz
		PFD	3	400	MHz
		VCO	400	1000	MHz

Device	Speed Grade	Name	Min.	Max.	Unit
	C5/I4	CLKOUT	3.125	500	MHz
		CLKIN	3	320	MHz
		PFD	3	320	MHz
		VCO	320	800	MHz
		CLKOUT	2.5	400	MHz
GW1N-1P5 GW1N-2	C7/I6	CLKIN	3	400	MHz
		PFD	3	400	MHz
		VCO	400	800	MHz
		CLKOUT	3.125	800	MHz
	C6/I5	CLKIN	3	400	MHz
		PFD	3	400	MHz
		VCO	400	800	MHz
		CLKOUT	3.125	800	MHz
	C5/I4	CLKIN	3	320	MHz
		PFD	3	320	MHz
		VCO	320	640	MHz
		CLKOUT	2.5	640	MHz

**Note!**

<sup>[1]</sup> The minimum output frequency of different channels may be different. The minimum output frequency of channel A is VCO/128, which is 3.125MHz/2.5MHz; The minimum frequency of the channel B/C/D needs to be determined based on whether they are cascaded, if they are not cascaded, it will be the same as channel A; if they are cascaded, it will need to be further divided by 128.

## 3.5 User Flash Characteristics

### 3.5.1 DC Characteristics

( $T_J = -40 \sim +100^\circ\text{C}$ ,  $V_{CC} = 0.95 \sim 1.05\text{V}$ ,  $V_{CCX} = 1.7 \sim 3.45\text{V}$ ,  $V_{SS} = 0\text{V}$ )



Table 3-22 GW1N-1/1S User Flash DC Characteristics

Symbol	Description	Specification			Unit
		Min.	Typ.	Max.	
Tj	Junction Temperature	-40	25	100	°C
I <sub>lkg</sub>	Leakage current	–	–	1 <sup>[1]</sup>	μA
I <sub>sb</sub>	Standby current	–	–	3 (Ta=25)	μA
		–	–	20 (Ta=85)	
I <sub>cc0</sub>	Idle current	–	–	1.3	mA
I <sub>cc1</sub>	Read current	–	–	2 (R <sub>mod</sub> =00)	mA
		–	–	2.5 (R <sub>mod</sub> =01)	mA
		–	–	3 (R <sub>mod</sub> =1x)	mA
I <sub>cc2</sub>	Page write current	–	–	2	mA
I <sub>cc3</sub>	Program/erase current	–	–	3	mA

**Note!**

<sup>[1]</sup> The leakage current of the Flash is included in the leakage current of the device, see Table 3-4 Hot Socketing Specifications.

Table 3-23 GW1N-2/4/9 User Flash DC Characteristics(I)

Symbol	Description	Specification			Unit
		Min.	Typ.	Max.	
Tj	Junction Temperature	-40	25	125	°C

Table 3-24 GW1N-2/4/9 User Flash DC Characteristics(II)<sup>[1], [4]</sup>

Name	Parameter	Max.		Unit	Wake-up time	Condition
		V <sub>CC</sub> <sup>[3]</sup>	V <sub>CCX</sub>			
Read mode(w/ 25ns)	I <sub>CC1</sub> <sup>[2]</sup>	2.19	0.5	mA	NA	Minimum clock period, 100% duty cycle , V <sub>IN</sub> = "1/0"
Write mode		0.1	12	mA	NA	–
Erase mode		0.1	12	mA	NA	–
Page erase mode		0.1	12	mA	NA	–
Static read current (25-50ns)	I <sub>CC2</sub>	980	25	μA	NA	XE=YE=SE="1", between T=T <sub>acc</sub> and T=50ns, the I/O current is 0mA. After T=50ns, the internal timer turns off read mode, and the I/O current turns out to be the standby current.
Standby mode	I <sub>SB</sub>	5.2	20	μA	0	V <sub>SS</sub> , V <sub>CCX</sub> , and V <sub>CC</sub>

**Note!**

- <sup>[1]</sup> These values are average DC currents and the peak currents will be higher than these average currents.
- <sup>[2]</sup>  $I_{CC1}$  calculation in different cycle time of  $T_{new}$ .
  - $T_{new} < T_{acc}$ : not allowed.
  - $T_{new} = T_{acc}$ : see the table above.
  - $T_{acc} < T_{new} - 50ns$ :  $I_{CC1} (new) = (I_{CC1} - I_{CC2})(T_{acc}/T_{new}) + I_{CC2}$
  - $T_{new} > 50ns$ :  $I_{CC1} (new) = (I_{CC1} - I_{CC2})(T_{acc}/T_{new}) + 50ns * I_{CC2}/T_{new} + I_{SB}$
  - $t > 50ns$ :  $I_{CC2} = I_{SB}$
- <sup>[3]</sup>  $V_{CC}$  must be greater than 1.08V from time zero of the wake-up time.
- <sup>[4]</sup> The leakage current of the Flash is included in the leakage current of the device, see Table 3-4 Hot Socketing Specifications.

### 3.5.2 Timing Parameters

( $T_J = -40 \sim +100^\circ C$ ,  $V_{CC} = 0.95 \sim 1.05V$ ,  $V_{CCX} = 1.7 \sim 3.45V$ ,  $V_{SS} = 0V$ )

Table 3-25 GW1N-1/1S User Flash Parameters

Symbol	Description	Specification			Unit
		Min.	Typ.	Max.	
Taa	Data access time	–	–	38	ns
Tcy	Read cycle time	43	–	–	ns
Taw	Aclk clock pulse high time	10	–	–	ns
Tawl	Aclk clock pulse low time	10	–	–	ns
Tas	Setup time	3	–	–	ns
Tah	Hold time	3	–	–	ns
Toz	Oe low to Dout Hi-Z	–	–	2	ns
Toe	Oe high to Dout valid	–	–	2	ns
Twcy	Write cycle time	40	–	–	ns
Tpw	Pw clock pulse high time	16	–	–	ns
Tpwl	Pw clock pulse low time	16	–	–	ns
Tpas	Page address setup time	3	–	–	ns
Tpah	Page address hold time	3	–	–	ns
Tds	Data setup time	16	–	–	ns
Tdh	Data hold time	3	–	–	ns
Ts0	Sequence 0 cycle time	6	–	–	μs
Ts1	Sequence 1 cycle time	15	–	–	μs
Ts2p	Aclk to Pe rise setup time	5	–	10	μs
Ts3	Sequence 3 cycle time	5	–	10	μs
Tps3	Pe fall to Aclk setup time	60	–	–	μs
Tpe	Erase time at Mode=1000	5.7	6	6.3	ms
	Program time at Mode=1100	1.9	2	2.1	ms
	Pre-program time at Mode=11xx	190	200	210	us

Table 3-26 GW1N-1P5/2/4/9 User Flash Parameters<sup>[1], [4], [5]</sup>

User Mode	Parameter	Symbol	Min.	Max.	Unit
Access time	WC1	$T_{acc}^{[2]}$	-	25	ns
	TC		-	22	ns
	BC		-	21	ns
	LT		-	21	ns
	WC		-	25	ns
Program/Erase to data storage setup time		$T_{nvs}$	5	-	μs
Data storage hold time		$T_{nvh}$	5	-	μs
Data storage hold time(mass erase)		$T_{nvh1}$	100	-	μs

User Mode	Parameter	Symbol	Min.	Max.	Unit
	Data storage to program setup time	$T_{pgs}$	10	-	$\mu\text{s}$
	Program hold time	$T_{pgh}$	20	-	ns
	Program time	$T_{prog}$	8	16	$\mu\text{s}$
	Write prepare time	$T_{wpr}$	>0	-	ns
	Write hold time	$T_{whd}$	>0	-	ns
	Control to program/erase setup time	$T_{cps}$	-10	-	ns
	SE to read control setup time	$T_{as}$	0.1	-	ns
	Positive pulse width of SE	$T_{pws}$	5	-	ns
	Address/data setup time	$T_{ads}$	20	-	ns
	Address/data hold time	$T_{adh}$	20	-	ns
	Data hold time	$T_{dh}$	0.5	-	ns
Address hold time in read mode	WC1	$T_{ah}$	25	-	ns
	TC	-	22	-	ns
	BC	-	21	-	ns
	LT	-	21	-	ns
	WC	-	25	-	ns
	Negative pulse width of SE	$T_{nws}$	2	-	ns
	Recovery time	$T_{rcv}$	10	-	$\mu\text{s}$
	Data storage time	$T_{hv}^{[3]}$	-	6	ms
	Erase time	$T_{erase}$	100	120	ms
	Mass erase time	$T_{me}$	100	120	ms
	Wake-up time of power-down to standby	$T_{wk\_pd}$	7	-	$\mu\text{s}$
	Standby hold time	$T_{sbh}$	100	-	ns
	$V_{CC}$ setup time	$T_{ps}$	0	-	ns
	$V_{CCX}$ hold time	$T_{ph}$	0	-	ns

**Note!**

- <sup>[1]</sup> The values are simulation data and are subject to change.
- <sup>[2]</sup> After XADR, YADR, XE, and YE are valid,  $T_{acc}$  starts at the rising edge of SE. DOUT will be kept before the next valid read operation starts.
- <sup>[3]</sup>  $T_{hv}$  is the cumulative time from the start of the write operation to the next data erase operation. The same address cannot be written twice before the next erase; the same memory cell cannot be written twice before the next erase. This limitation is for security reasons.
- <sup>[4]</sup> All waveforms have a 1ns rising time and a 1ns falling time.
- <sup>[5]</sup> Control signals(X, YADR, XE, and YE) need to be held for at least  $T_{acc}$ , which starts at the rising edge of SE.

### 3.5.3 Timing Diagrams (GW1N-1/ GW1N-1S)

Figure 3-1 Read Mode

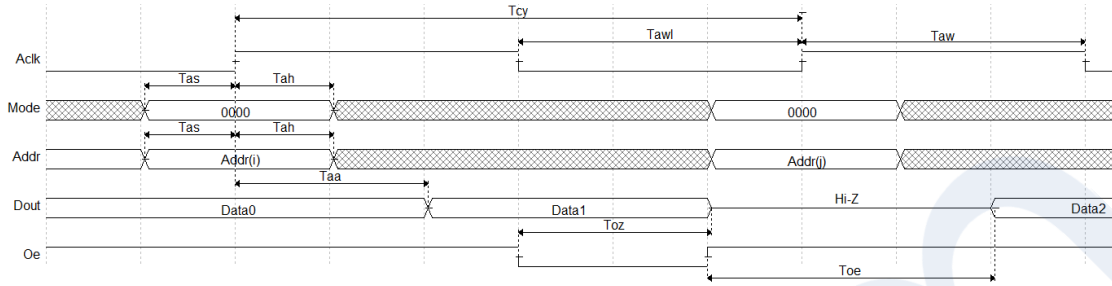

**Note!**

Read cycles when Seq=0. The Addr signal contains Ra, Ca, Rmod, and Rbytesel.

Figure 3-2 Write Page Latch Mode

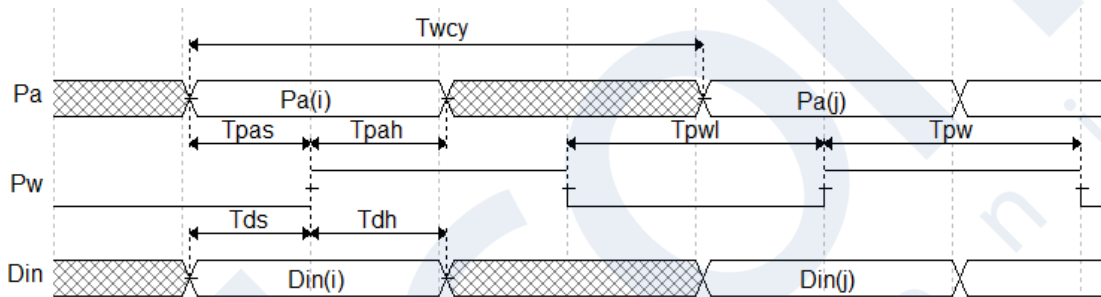

**Note!**

Write page latch cycles when Seq=0, Mode=0000.

Figure 3-3 Clear Page Latch Mode

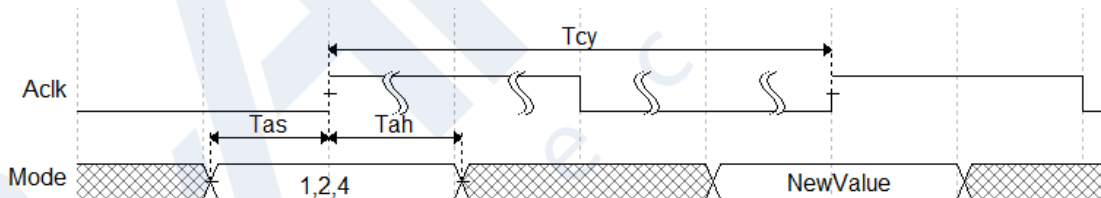

**Note!**

The timing parameters of setting PEP and writing data to all pages are the same as those of clearing page latches, except that the MODE value is different.

Figure 3-4 High Level Cycles

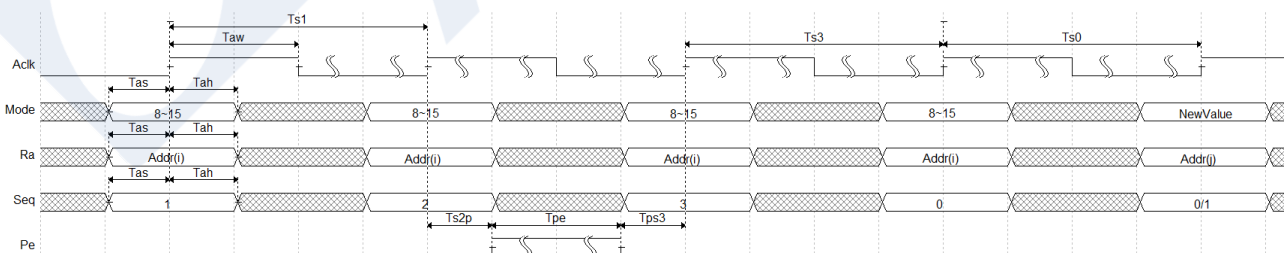

### 3.5.4 Timing Diagrams (GW1N-1P5/2/4/9)

Figure 3-5 Read Timing

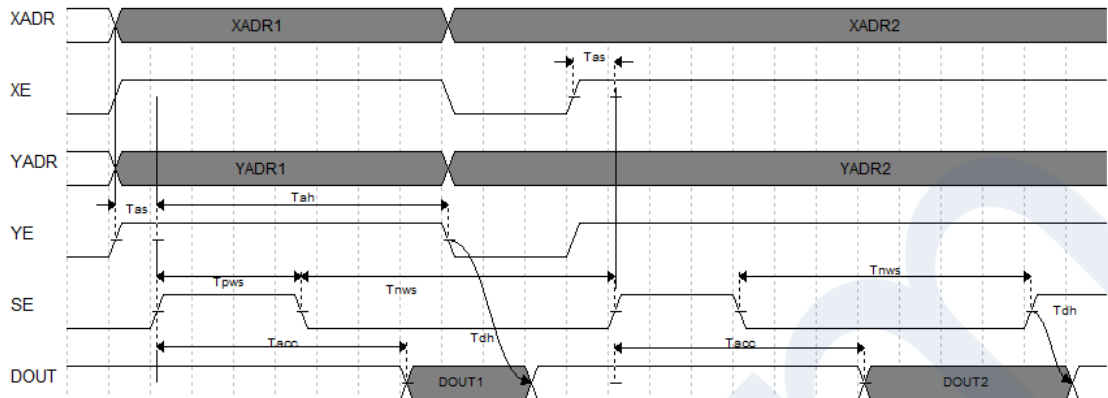

Figure 3-6 Program Timing

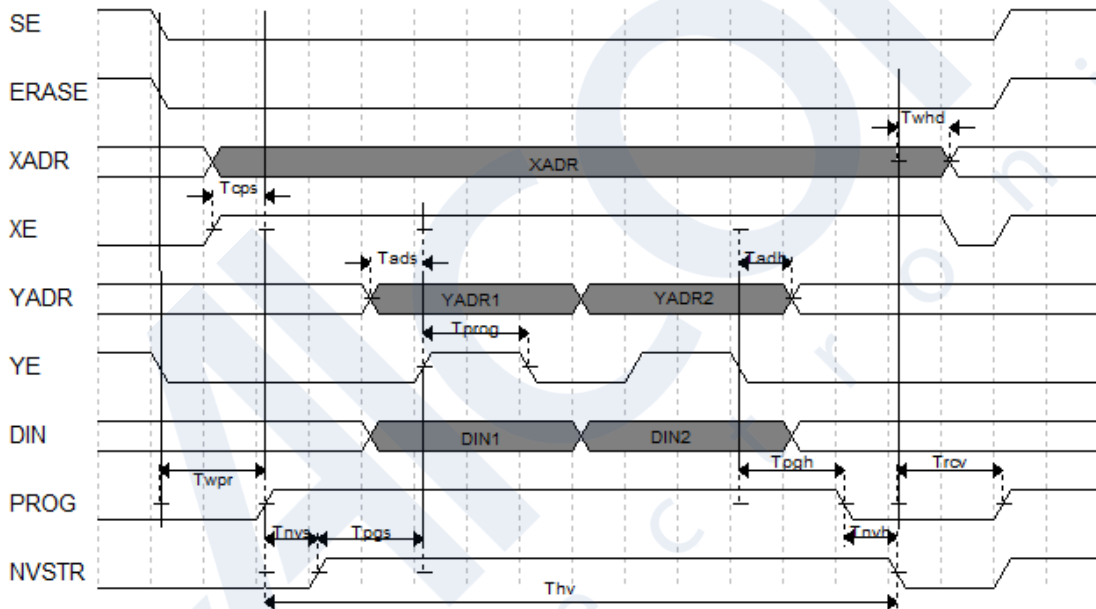
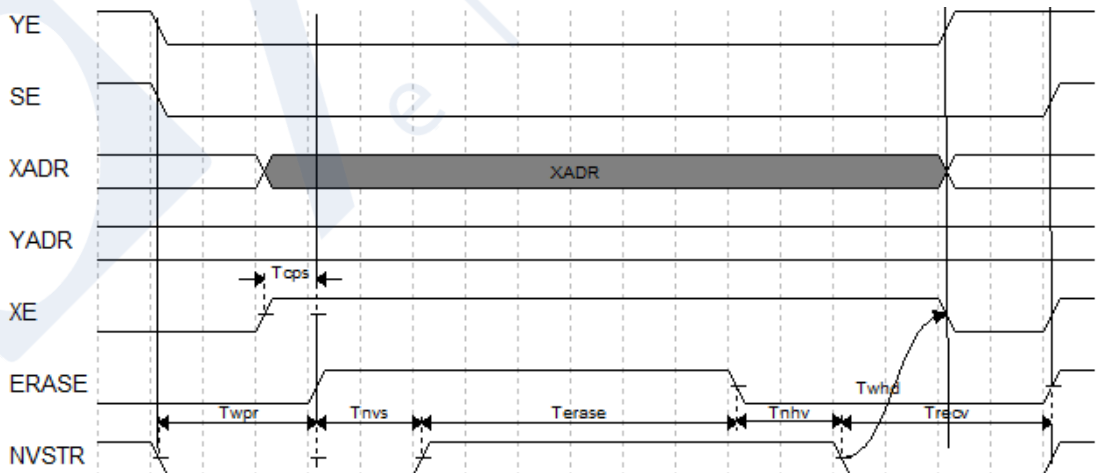

Figure 3-7 Erase Timing



## 3.6 Configuration Interface Timing Specification

The GW1N series of FPGA products support seven GowinCONFIG modes: AUTO BOOT, SSPI, MSPI, DUAL BOOT, SERIAL, CPU, and I<sup>2</sup>C Slave. For more information, please refer to [UG290, Gowin FPGA Products Programming and Configuration User Guide](#).



# 4 Ordering Information

## 4.1 Part Naming

### Note!

- GW1N-1S supports LV version only.
- For more information about the packages, please refer to [1.2 Product Resources](#) and [1.3 Package Information](#).

Figure 4-1 Part Naming Examples - ES

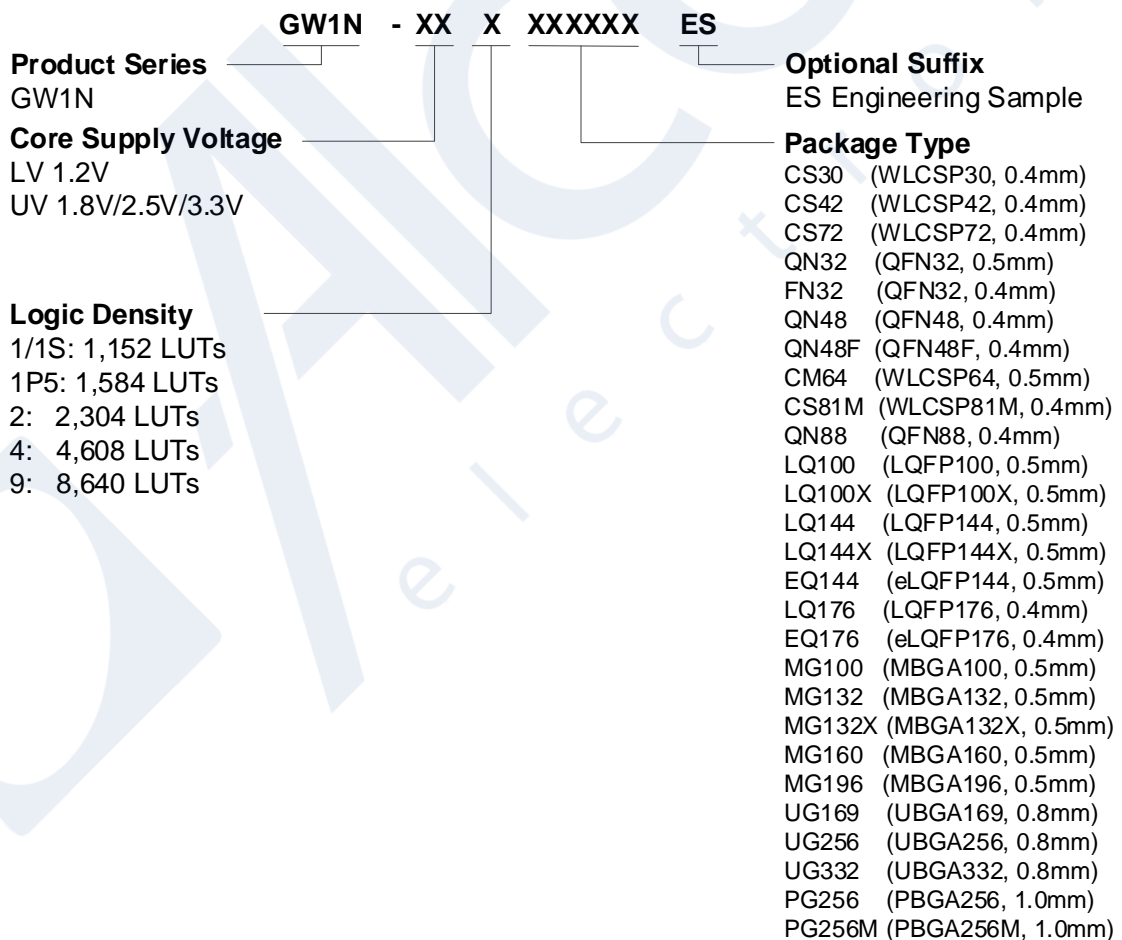
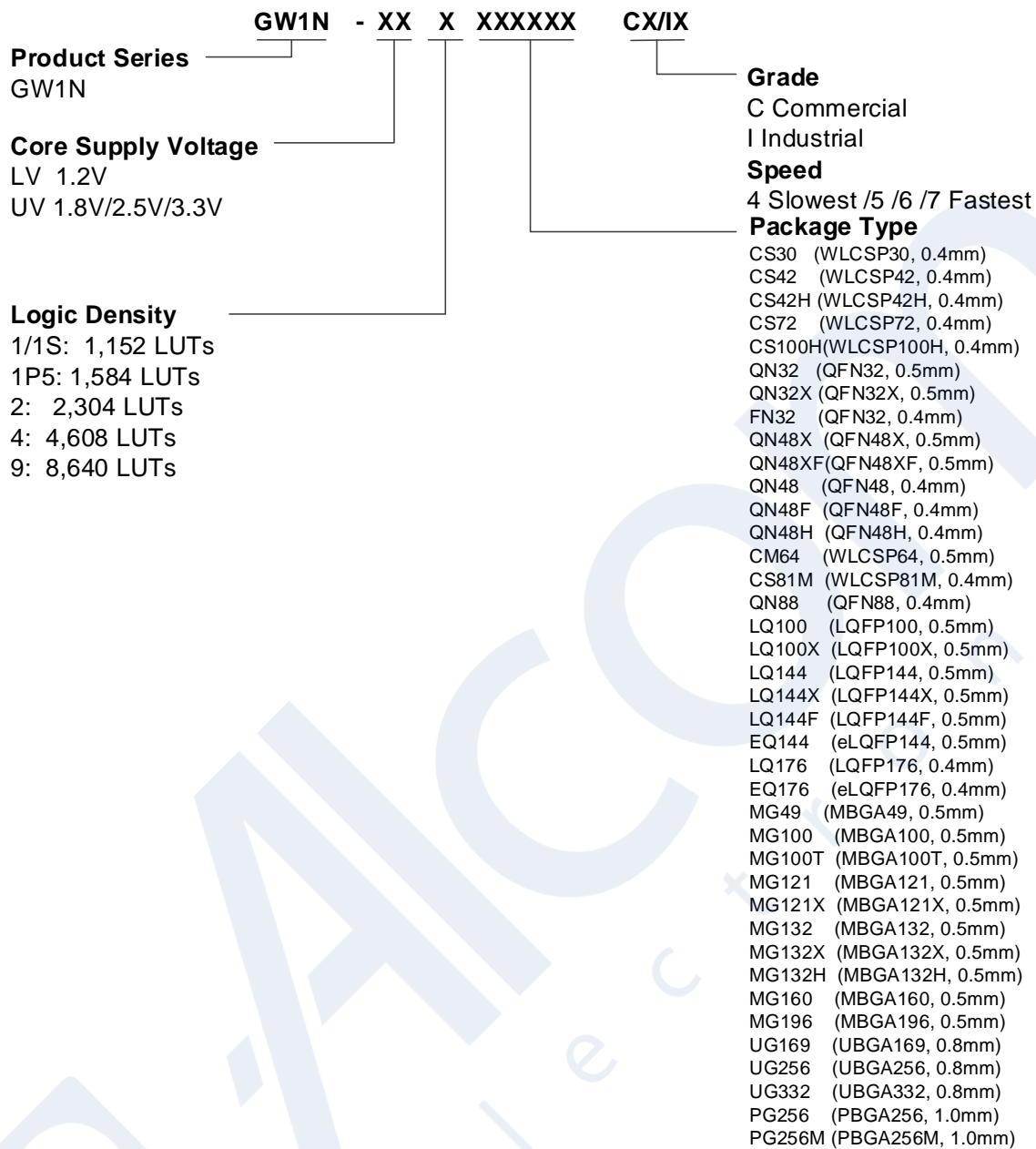



Figure 4-2 Part Naming Examples - Production

**Note!**

- The LittleBee® family devices and Arora family devices of the same speed grade have different speeds.
- Both “C” and “I” are used in Gowin’s part name marking for one device. GOWIN devices are screened using industrial standards, so the same device can be used for both industrial (I) and commercial (C) applications. The maximum temperature of the industrial grade is 100°C, and the maximum temperature of the commercial grade is 85°C. Therefore, if the chip meets speed grade 7 in commercial grade applications, its speed grade will be 6 in industrial grade applications.

## 4.2 Package Markings

Gowin’s devices have markings on the their surfaces, as shown in Figure 4-3.

Figure 4-3 Package Marking Examples

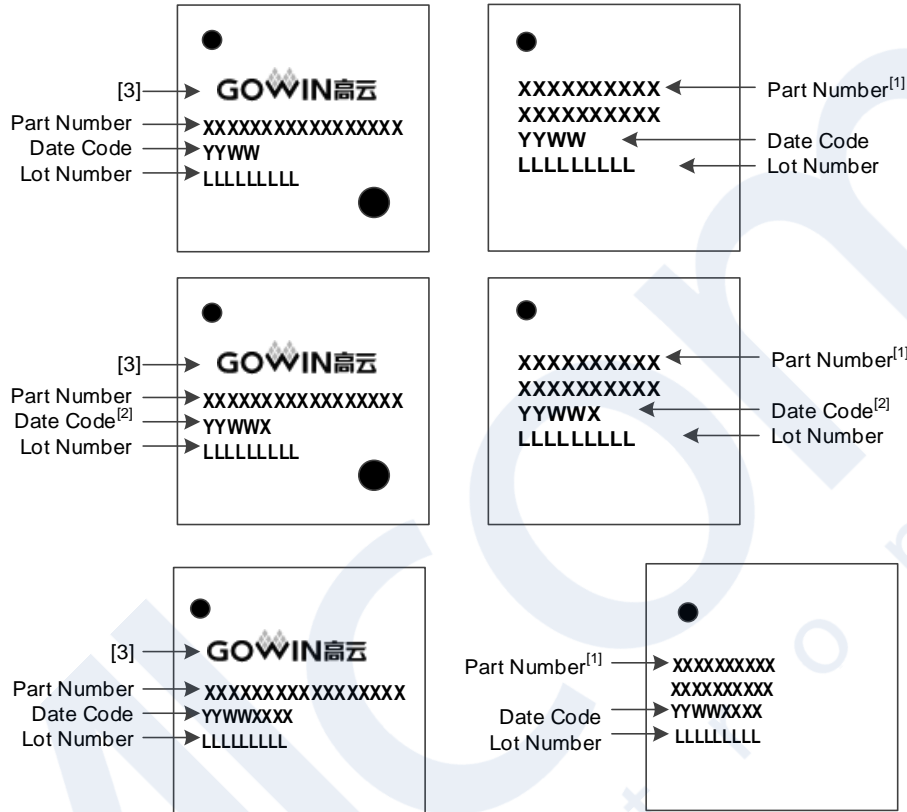

**Note!**

- <sup>[1]</sup> The first two lines in the right figure(s) above are both the “Part Number”.
- <sup>[2]</sup> The Date Code followed by an “X” is for X version devices.
- <sup>[3]</sup> Whether the package marking bears the Gowin Logo or not depends on the package type, package size, and Part Number length. The above figure are only examples of the package markings.

# 5 About This Guide

## 5.1 Purpose

This datasheet provides a comprehensive overview of the GW1N series of FPGA products, including their features, resources, architecture, AC/DC characteristics, and ordering details. It aims to enhance accessibility and facilitate the effective utilization of Gowin's devices.

## 5.2 Related Documents

The latest documents are available at [www.gowinsemi.com](http://www.gowinsemi.com).

- [UG290, Gowin FPGA Products Programming and Configuration User Guide](#)
- [UG103, GW1N series of FPGA Products Package and Pinout Manual](#)
- [UG107, GW1N-1 Pinout](#)
- [UG167, GW1N-1S Pinout](#)
- [UG105, GW1N-4 Pinout](#)
- [UG114, GW1N-9 Pinout](#)
- [UG171, GW1N-2 Pinout](#)
- [UG174, GW1N-1P5 Pinout](#)

## 5.3 Terminology and Abbreviations

The terminology and abbreviations used in this manual are shown in Table 5-1.

Table 5-1 Terminology and Abbreviations

Terminology and Abbreviations	Full Name
ALU	Arithmetic Logic Unit
BSRAM	Block Static Random Access Memory
CFU	Configurable Function Unit
CLS	Configurable Logic Section

Terminology and Abbreviations	Full Name
CRU	Configurable Routing Unit
CS	WLCSP
CSI	Camera Serial Interface
DCS	Dynamic Clock Selector
DP	True Dual Port 16K BSRAM
DQCE	Dynamic Quadrant Clock Enable
DSI	Display Serial Interface
DSP	Digital Signal Processing
FF	Flip-Flop
FPGA	Field Programmable Gate Array
GPIO	Gowin Programmable I/O
IOB	Input/Output Block
LQ	LQFP
LUT4	4-input Look-up Table
LUT5	5-input Look-up Table
LUT6	6-input Look-up Table
LUT7	7-input Look-up Table
LUT8	8-input Look-up Table
MG	MBGA
MIPI	Mobile Industry Processor Interface
PG	PBGA
PLL	Phase-locked Loop
QN	QFN
REG	Register
SDP	Semi-Dual Port 16K BSRAM
SP	Single Port 16K BSRAM
SSRAM	Shadow Static Random Access Memory
TBD	To Be Determined
UG	UBGA

## 5.4 Support and Feedback

Gowin Semiconductor provides customers with comprehensive technical support. If you have any questions, comments, or suggestions, please feel free to contact us directly using the information provided below.

Website: [www.gowinsemi.com](http://www.gowinsemi.com)

E-mail: [support@gowinsemi.com](mailto:support@gowinsemi.com)

