

Bridgetek Pte Ltd

IDM2040-43A

Datasheet



1 Introduction

The IDM2040-43A is an intelligent display module featuring a 4.3" 480x272 resolution TFT LCD panel with capacitive touch panel. The module carries Bridgetek's new embedded video engine controller BT883Q supported by a low-cost high-performance Raspberry PI RP2040 microcontroller. Apart from on board UART, I2C and SPI interfaces, users can also extend communication with two add-on accessories board to include RS232 and RS485 channels.

The input power source can either be from USB host/charger or UART-SIP connector.

With the use of a Raspberry Pi MCU RP2040, the IDM2040-43A module allows easy programming with various Circuit Python or Micro Python libraries.

1.1 Features

- BT883Q new generation of EVE controller.
- Supports 4.3" 480x272 LCD with capacitive touch screen.
- On board audio power amplifier and audio connector for external speaker and audio line in.
- RP2040 MCU with 8 MB on-board flash memory programmable with Circuit Python (libraries provided).
- Type-C port for RP2040 USB DFU or debug.
- Micro-SD card socket.
- 2x Stemma QT (QWIIC) I2C peripheral sockets.
- SPI pin headers for Adafruit Wi-Fi module or other peripherals.
- 6-position header for mating with FTDI TTL cables
- RS232 transceiver adaptor (optional add on module).
- RS485 transceiver adaptor (optional add on module).
- Hardware reset button.
- RP2040 DFU button.
- Precision fitted bezel in black.
- CE/FCC/UKCA certified



Singel 3 | B-2550 Kontich | Belgium | Tel. +32 (0)3 458 30 33
 info@alcom.be | www.alcom.be

Rivium 1e straat 52 | 2909 LE Capelle aan den IJssel | The Netherlands
 Tel. +31 (0)10 288 25 00 | info@alcom.nl | www.alcom.nl

Neither the whole nor any part of the information contained in, or the product described in this manual, may be adapted or reproduced in any material or electronic form without the prior written consent of the copyright holder. This product and its documentation are supplied on an as-is basis and no warranty as to their suitability for any particular purpose is either made or implied. Bridgetek Pte Ltd will not accept any claim for damages howsoever arising as a result of use or failure of this product. Your statutory rights are not affected. This product or any variant of it is not intended for use in any medical appliance, device or system in which the failure of the product might reasonably be expected to result in personal injury. This document provides preliminary information that may be subject to change without notice. No freedom to use patents or other intellectual property rights is implied by the publication of this document. Bridgetek Pte Ltd, 1 Tai Seng Avenue, #03-05, Singapore 4536464. Singapore Registered Company Number: 201542387H

2 Ordering Information

Part No.	Description
IDM2040-43A	Intelligent Display Module 4.3-inch TFT LCD with CTP and bezel
IDM-RS232	UART to RS232 Interface Board
IDM-RS485	UART to RS485 Interface Board

Table of Contents

1	Introduction.....	1
1.1	Features.....	1
2	Ordering Information.....	2
3	Hardware Description	5
3.1	IDM2040-43A Module	5
3.2	Power supply	8
3.3	Microcontroller- Raspberry Pi RP2040.....	8
3.4	Connectors & Buttons	8
3.5	RS232/RS485 Daughter Boards	12
4	Specifications.....	15
4.1	Electrical Specifications	15
4.2	Display Specifications	15
4.3	Optical Specifications.....	15
5	Board Schematics	17
6	Mechanical Dimensions.....	20
6.1	IDM2040-43A PCBA Dimensions	20
6.2	IDM2040-43A Product Dimensions.....	20
6.3	IDM-RS232 PCBA Dimensions	23
6.4	IDM-RS485 PCBA Dimensions	23
6.5	Assembling Bezel and Panel Mounting	24
7	Software Setup Information	26
7.1	C/C++ SDK Setup	26
7.2	MicroPython SDK Setup.....	26
7.3	Circuitpython SDK Setup	27
7.4	Bridgetek CircuitPython SDK Setup	28
8	Disclaimer Notice: Use of Third-Party Software or Websites	29

9 Contact Information.....	30
Appendix A – References.....	31
Document References	31
Acronyms and Abbreviations	31
Appendix B – List of Tables & Figures.....	32
List of Tables	32
List of Figures	32
Appendix C – Revision History.....	34

3 Hardware Description

3.1 IDM2040-43A Module

The IDM2040-43A module consists of a 4.3" TFT LCD with 480x272 resolution and capacitive touch panel connected to HB_080 PCBA and encased in black plastic frame and bezel. The size of the module measures 132.7mm (L) x 93.5mm (H) x 26mm (W).



Figure 1 - IDM2040-43A Module - Front View



Figure 2 - IDM2040-43A Module - Back View

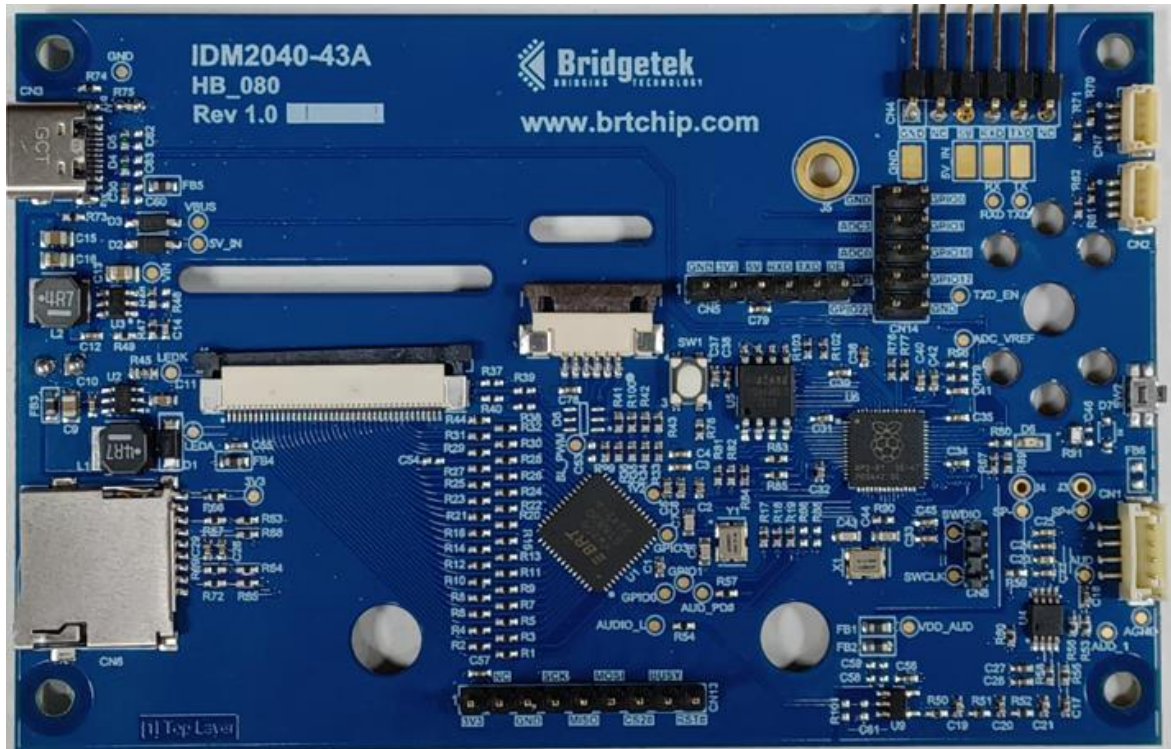

Figure 3 - IDM2040-43A PCBA - Front View

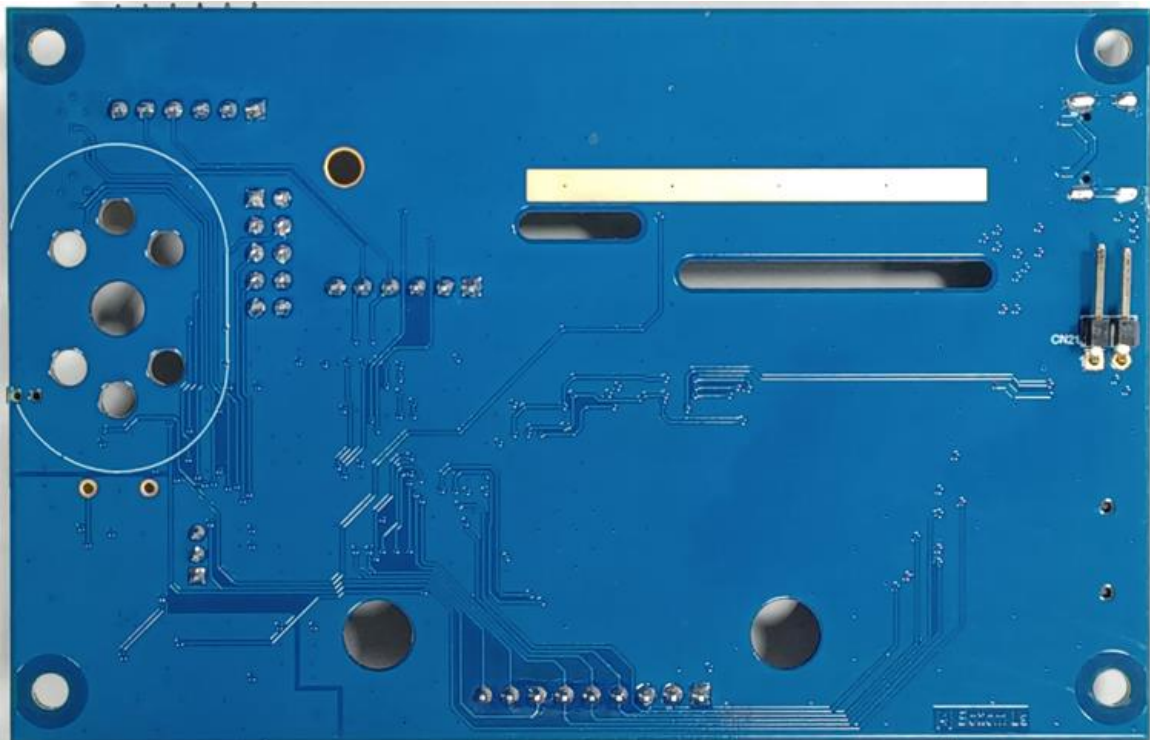

Figure 4 - IDM2040-43A PCBA – Back View

Key Features:

- ❖ Bridgetek's BT883Q EVE chip for graphics, touch and audio controller
- ❖ Raspberry Pi RP2040 microcontroller
- ❖ External Quad-SPI Flash with eExecute In Place (XIP)
- ❖ Type-C USB port for power and data (and for reprogramming Flash)
- ❖ One 40-pin 0.5mm pitch FPC connector for LCD interface
- ❖ One 6-pin 1mm pitch FPC connector for capacitive touch panel interface
- ❖ One 4-position 1.5mm JST male connector for 8-ohm 1W speaker
- ❖ Micro-SD card socket
- ❖ Two 4-position 1mm pitch JST male connectors (Stemma QT/ QWIIC) for I2C peripheral interface
- ❖ One 9-position 2.54mm Harwin male header for SPI peripheral interface
- ❖ One 6-position 2.54mm Harwin male header for mating with IDM-RS232 or IDM-RS485 daughter boards.
- ❖ One 6-position 2.54mm Harwin male R/A header for mating with FTDI TTL cables (e.g., TTL-234X-5V)
- ❖ One 2x5 10-position 2.54mm Harwin male header for GPIO/PWM/ADC interface
- ❖ One 3-position 2mm Harwin male header for ARM Serial Wire Debug (SWD) port
- ❖ Bootsel button for entering USB device mode
- ❖ Hardware Reset Button

3.2 Power supply

There are 2 options for powering the IDM2040-43A module:

- 5V/0.5A USB Type-C connector - CN3.
- Or 5V/0.5A 1x6 position 2.54mm Harwin male header – CN4/CN5.

Both power inputs are summed using Schottky diodes so the source with higher voltage will be used to power the system and back flow current will be blocked. Power will then go to the DC-DC Buck switching regulator to output the 3.3V supply for powering up the system.

3.3 Microcontroller- Raspberry Pi RP2040

The Raspberry Pi RP2040 microcontroller unit used in the module has the following key features:

- Dual ARM Cortex-M0+ @ 133MHz
- 264kB on-chip SRAM in six independent banks
- Support 8MB of on-board Flash memory via dedicated QSPI bus
- Type-C USB port supporting USB2.0 Full-speed device function; reprogramming the Flash can be achieved by simply dragging and dropping a file onto the RP2040 which appears as a mass storage device.
- 26 multi-function 3.3V General Purpose I/O (GPIO) with 23 GPIOs being digital-only and 3 ADC-capable GPIOs.
- 3-pin ARM Serial Wire Debug (SWD) port; the standard Serial Wire Debug (SWD) port can reset the system and load and run code without any button presses as well as for debugging purpose.

For full details of the Raspberry Pi RP2040 MCU, please refer to the [RP2040 Datasheet](#).

3.4 Connectors & Buttons

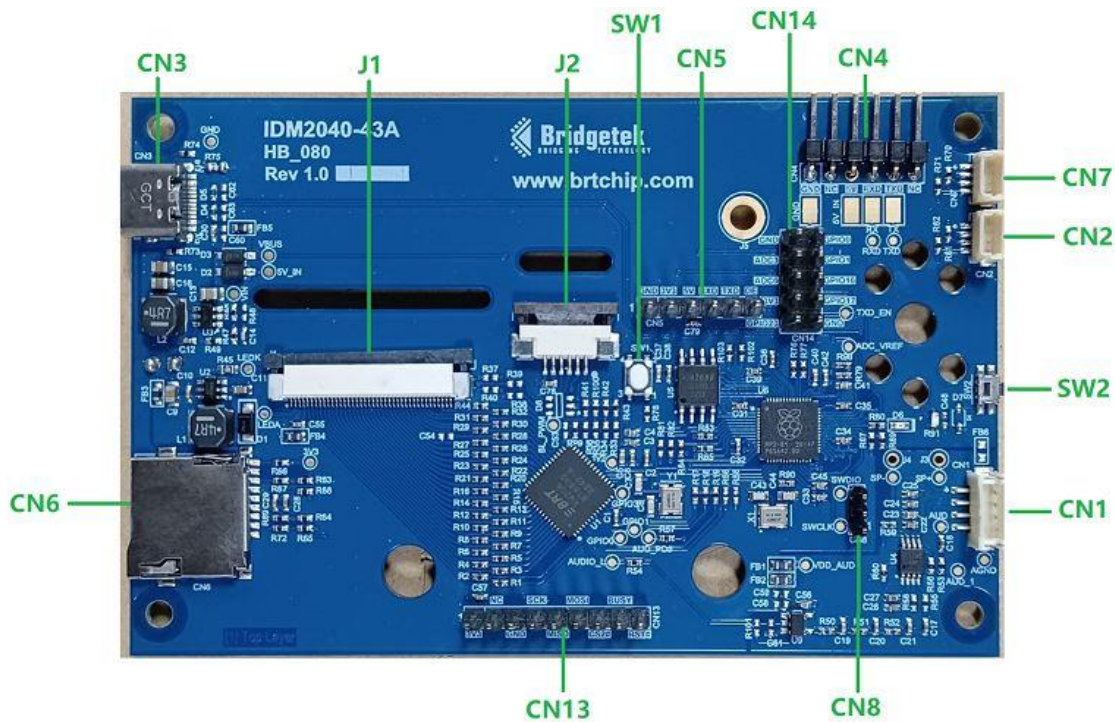

Figure 5 – Connectors and buttons on IDM2040-43A

Connectors and buttons of IDM2040-43A are described in the following sections.

Note: All GP(IO)s stated below can also be configured as GPIO or PWM.

- **CN1** is a 4-position connector header for audio output to 8 ohm/1W speaker and external audio line-in input.

Pin No.	Name	Type	Description
1	SP-	O	Audio output for speaker
2	SP+	O	Audio output for speaker
3	AGND	P	Analog Ground
4	AUD	I	Audio line-in input

Table 1 – CN1 Pinout

- **CN2 & CN7** are the Stemma QT/ QWIIC connectors for I2C interface with output power supply.

Pin No.	Name	Type	Description	Pin Configurable Function
1	GND	P	Ground	-
2	VCC3V3	P	3.3V output power supply	-
3	CN2: I2C0_SDA CN7: I2C1_SDA	I/O	I2C Serial Bus, Data Line	CN2: GP20/ SPI0_RX/ UART1_TX/ I2C0_SDA CN7: GP18/SPI0_SCK/ UART0_CTS/ I2C1_SDA
4	CN2: I2C0_SCL CN7: I2C1_SCL	O	I2C Serial Bus, Clock Line	CN2: GP21/ SPI0_CS _n / UART1_RX/ I2C0_SCL CN7: GP19/SPI0_TX/ UART0_RTS/ I2C1_SCL

Table 2 – CN2 & CN7 Pinout

- **CN3** is a USB type C receptacle connector use for:
 - powering up the module
 - communication between PC and RP2040 MCU,
 - device firmware updating and debugging. The port communicates with PC via USB as a virtual com port.

- **CN4** is use for communication with PC via MCU UART1 cum input power source.

Pin No.	Name	Type	Description
1	GND	P	Ground
2	NC	-	No connection
3	5V_IN	P	5V input power source
4	TTL_RXD	I	RP2040 UART1 communication receive port
5	TTL_TXD	O	RP2040 UART1 communication transmit port
6	NC	-	No connection

Table 3 – CN4 Pinout

- **CN5** is use for connection to RS232 and RS485 daughter boards.

Pin No.	Name	Type	Description
1	GND	P	Ground
2	VCC3V3	P	3.3V output power supply
3	5V_IN	P	5V input power source

4	TTL_RXD	I	RP2040 UART1 communication receive port
5	TTL_TXD	O	RP2040 UART1 communication transmit port
6	DE	O	Driver output enable pin (RS485 interface)

Table 4 – CN5 Pinout

- **CN6** is a Micro SD card socket supporting single SPI communication mode and auto card detection.
- **CN8** is a 3-position vertical pin header connector for MCU’s ARM Serial Wire Debug (SWD) port.

Pin No.	Name	Type	Description	Pin Configurable Function
1	SWCLK	I	Serial Wire Debug, Clock	SWCLK
2	GND	P	Ground	-
3	SWDIO	I/O	Serial Wire Debug, I/O	SWDIO

Table 5 – CN8 Pinout

- **CN13** is a 9-position vertical pin header connector for SPI interface with output power supply. The SPI bus signals are shared with Micro-SD card except for the chip select signal.

Pin No.	Name	Type	Description	Pin Configurable Function
1	VCC3V3	P	3.3V output power supply	-
2	NC	-	No connection	-
3	GND	P	Ground	-
4	SPI1_SCK	O	SPI1 clock output	GP10/ SPI1_SCK/ UART1_CTS/ I2C1_SDA
5	SPI1_MISO	I	SPI master input, slave output.	GP12/ SPI1_RX/ UART0_TX/ I2C0_SDA
6	SPI1_MOSI	O	SPI master output, slave input.	GP11/ SPI1_TX/ UART1_RTS/ I2C1_SCL
7	SPI1_CS2#	O	SPI Chip Select output for external SPI peripheral device, active low. On board 10kΩ pull-up to 3.3V.	GP22/ SPI0_SCK/ UART1_CTS/ I2C1_SDA
8	BUSY	I	Reserve for AdafruitAirLift Breakout Wi-Fi module	GP14/ SPI1_SCK/ UART0_CTS/ I2C1_SDA
9	RESET#	O	Reserve for AdafruitAirLift Breakout Wi-Fi module	GP15/ SPI1_TX/ UART0_RTS/ I2C1_SCL

Table 6 – CN13 Pinout

- **CN14** is a 2x5, 10-position vertical pin header use for GPIO/ADC/PWM interface with output power supply.

Pin No.	Name	Type	Description	Pin Configurable Function
1	GPIO0	I/O	GPIO	GP0/ SPI0_RX/ UART0_TX/ I2C0_SDA
2	GND	P	Ground	-
3	GPIO1	I/O	GPIO	GP1/ SPI0_CS _n / UART0_RX/ I2C0_SCL
4	GPIO29_ADC3	I/O	GPIO	GP29/ SPI1_CS _n / UART0_RX/ I2C0_SCL/ ADC
5	GPIO16	I/O	GPIO	GP16/ SPI0_RX/ UART0_TX/ I2C0_SDA
6	GPIO26_ADC0	I/O	GPIO	GP26/ SPI1_SCK/ UART1_CTS/ I2C1_SDA/ ADC
7	GPIO17	I/O	GPIO	GP17/ SPI0_CS _n / UART0_RX/ I2C0_SCL
8	VCC3V3	P	3.3V output power supply	-
9	GND	P	Ground	-
10	GPIO23	I/O	GPIO	GP23/ SPI0_TX/ UART1_RTS/ I2C1_SCL

Table 7 – CN14 Pinout

- **SW1** is the BOOTSEL button to put RP2040 MCU into programming mode to program firmware into the 8MB flash memory connected to QSPI bus.
- **SW2** is hardware reset button to reset RP2040 MCU.

3.5 RS232/RS485 Daughter Boards

3.5.1 RS232 Daughter Board

RS232 daughter board is an interface board for IDM2040-43A that translates the UART1 signal from MCU to RS232 communication channel. The diagram below shows the correct orientation of inserting the RS232 daughter board onto main PCBA. Snap lock standoffs will be provided for further locking security.

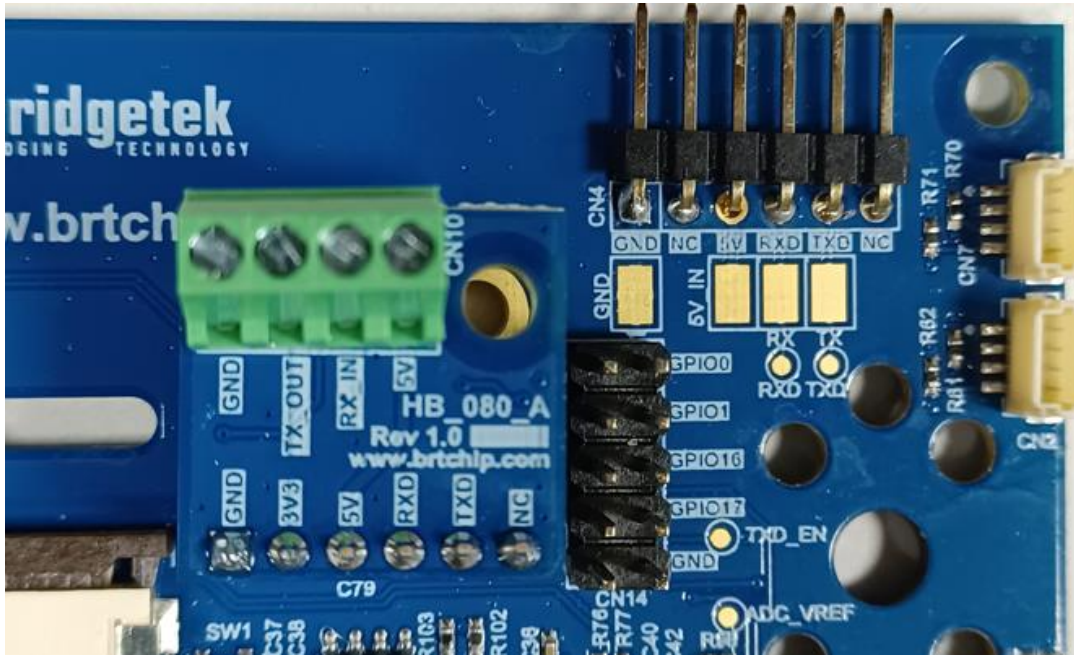

Figure 6 – IDM-RS232 Daughter Board Mounting Orientation

3.5.2 Connectors on RS232 Daughter Board

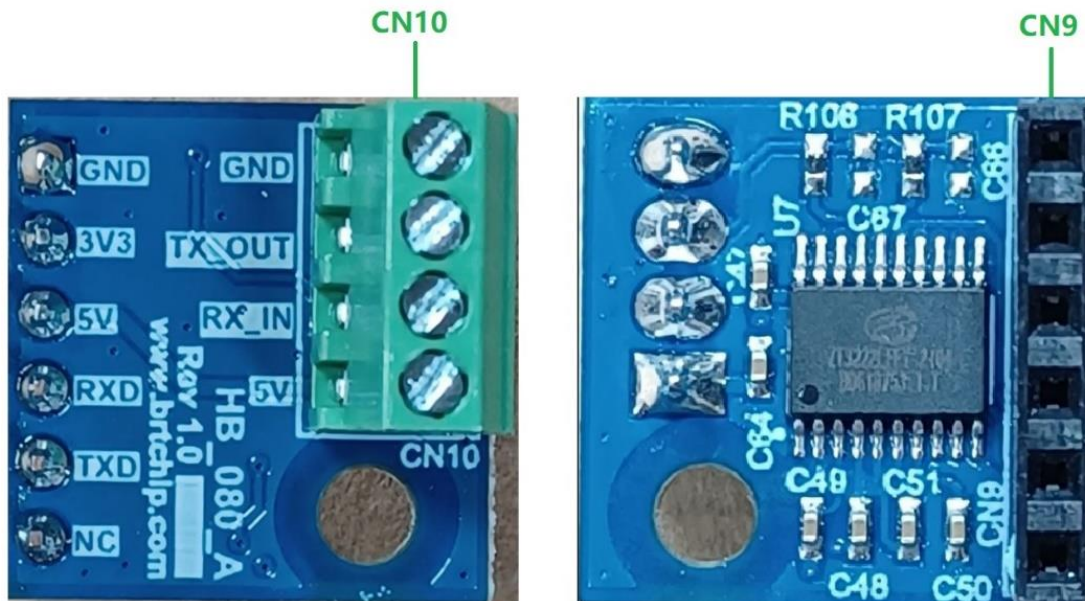

Figure 7 – Connectors on IDM-RS232

- **CN10** is a 4-position terminal block use for RS232 communication cum input power source.

Pin No.	Name	Type	Description
1	5V	P	5V input power source
2	RX_IN	I	RS232 communication receive port
3	TX_OUT	O	RS232 communication transmit port
4	GND	P	Ground

Table 8 - CN10 Pinout

- **CN9** is a 6-position housing use for connection with IDM2040-43A CN5 header connected to MCU's UART1 port and input power source.

Pin No.	Name	Type	Description
1	GND	P	Ground
2	VCC3V3	P	3.3V input power source
3	5V_IN	P	5V output power supply
4	RXD	O	To RP2040 UART1 communication receive port
5	TXD	I	To RP2040 UART1 communication transmit port
6	NC	-	No connection

Table 9 - CN9 Pinout

3.5.3 RS485 Daughter Board

RS485 daughter board is an interface board for IDM2040-43A that translates the UART1 signal from MCU to RS485 communication channel. The diagram below shows the correct orientation of inserting the RS485 daughter board onto the main PCBA. Snap lock standoffs will be provided for further locking security.



Figure 8 – IDM-RS485 Daughter Board Mounting Orientation

3.5.4 Connectors on RS485 Daughter Board

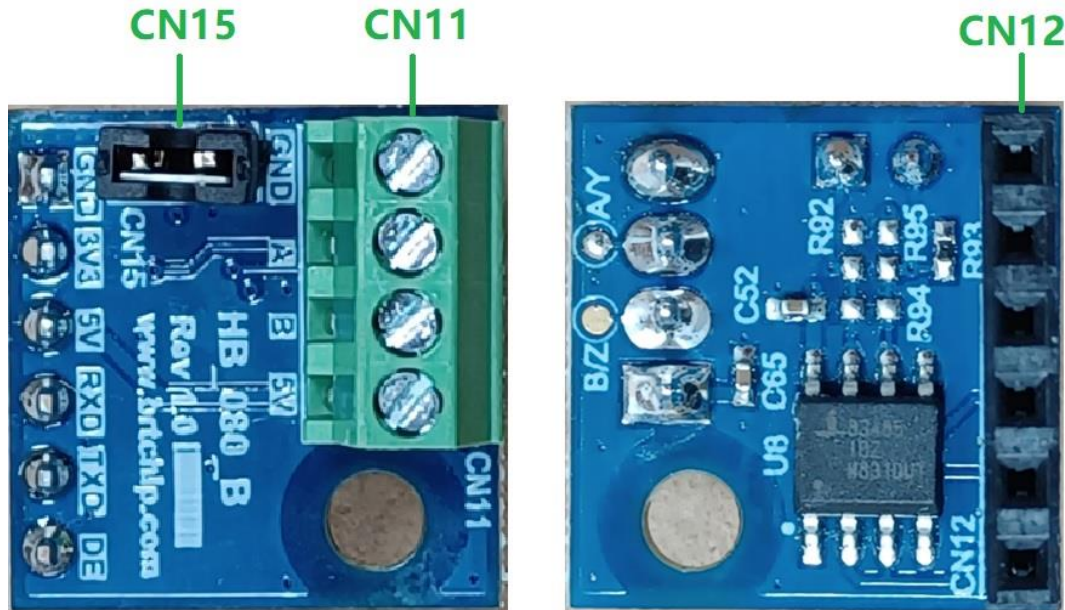

Figure 9 - Connectors on IDM-RS485

- **CN11** is a 4-position terminal block use for RS485 communication cum input power source.

Pin No.	Name	Type	Description
1	5V	P	5V input power source
2	B	I/O	Inverting driver/receiver
3	A	I/O	Noninverting driver/receiver
4	GND	P	Ground

Table 10 - CN11 Pinout

- **CN12** is a 6-position housing use for connection with IDM2040-43A CN5 header connected to MCU's UART1 port and input power source.

Pin No.	Name	Type	Description
1	GND	P	Ground
2	VCC3V3	P	3.3V input power source
3	5V_IN	P	5V output power supply
4	RX	O	To RP2040 UART1 communication receive port
5	TX	I	To RP2040 UART1 communication transmit port
6	TX_EN	-	Driver output enable pin

Table 11 - CN12 Pinout.

- **CN15** is a 2x1 header when shorted with shunt will provide 120-ohm termination resistance across port A and B. This is to meet RS485 termination requirements if the module is the first or last device in a multi-drop RS485 System.

4 Specifications

4.1 Electrical Specifications

Parameter	Description	Minimum	Typical	Maximum	Units	Notes
VBUS	supply voltage	4.5	5.0	5.5	V	CN3
+5V	supply voltage	4.5	5.0	5.5	V	CN4
+5V	supply voltage	4.5	5.0	5.5	V	CN5
Icc1_3.3V	VCC=3.3V operating current	-	225	-	mA	With LCD and Backlight LED on
Icc2_3.3V	VCC=3.3V operating current	-	260	-	mA	With 8 OHM speaker connected
Voh	Output Voltage High	2.4	-	-	V	
Vol	Output Voltage Low	-	-	0.4	V	
Vih	Input High Voltage	2.0	-	-	V	
Vil	Input Low Voltage	-	-	0.8	V	
T	Operating temperature	-20	-	+70	°C	

Table 12 – Operating Voltage and Current

4.2 Display Specifications

Item	Spec	Units	Notes
LCD Type	TFT	-	
Display Colours	16.7M	-	
Display active area	95.04(H) * 53.86(V)	mm	4.3-inch diagonal
Number of Pixels	480*272	dots	
Backlight	5X2 white LEDs	-	
Touch screen	5-finger capacitive touch	-	

Table 13 – LCD and Touch Information

4.3 Optical Specifications

Item	Symbol	Condition	Min.	Typ.	Max.	Unit	Note
Brightness	Bp	$\theta=0^\circ$ $\Phi=0^\circ$	-	450	-	Cd/m ²	1
Uniformity	ΔBp		75	-	-	%	1,2
Viewing Angle	3:00	$Cr \geq 10$	-	65	-	Deg	3
	6:00		-	55	-		
	9:00		-	65	-		
	12:00		-	65	-		
Contrast Ratio	Cr	$\theta=0^\circ$	350	500	-	-	4
Response	Tr		-	10	-	ms	

Time	Tf		$\Phi=0^\circ$	-	10	-	ms	5				
Color of CIE Coordinate	W	x	$\vartheta=0^\circ$ $\Phi=0^\circ$	-0.05	0.28	+0.05	-	1,6				
		y			0.33		-					
	R	x			0.51		-					
		y			0.34		-					
	G	x			0.31		-					
		y			0.56		-					
	B	x			0.15		-					
		y			0.14		-					
	NTSC Ratio	S			50		60		-	%		

Table 14 – Optical Specifications

Note 1: The parameter is slightly changed by temperature, driving voltage and material

Note 2: The data are measured after LEDs are turned on for 15 minutes. LCM displays full white. The brightness is the average value of 9 measured spots. Measurement equipment BM-7 ($\Phi 5\text{mm}$)

Measuring condition:

- Measuring surroundings: Dark room.
- Measuring temperature: $T_a=25^\circ\text{C}$.
- Adjust operating voltage to get optimum contrast at the center of the display.

Measured value at the center point of LCD panel after more than 15 minutes while backlight turned on.

5 Board Schematics

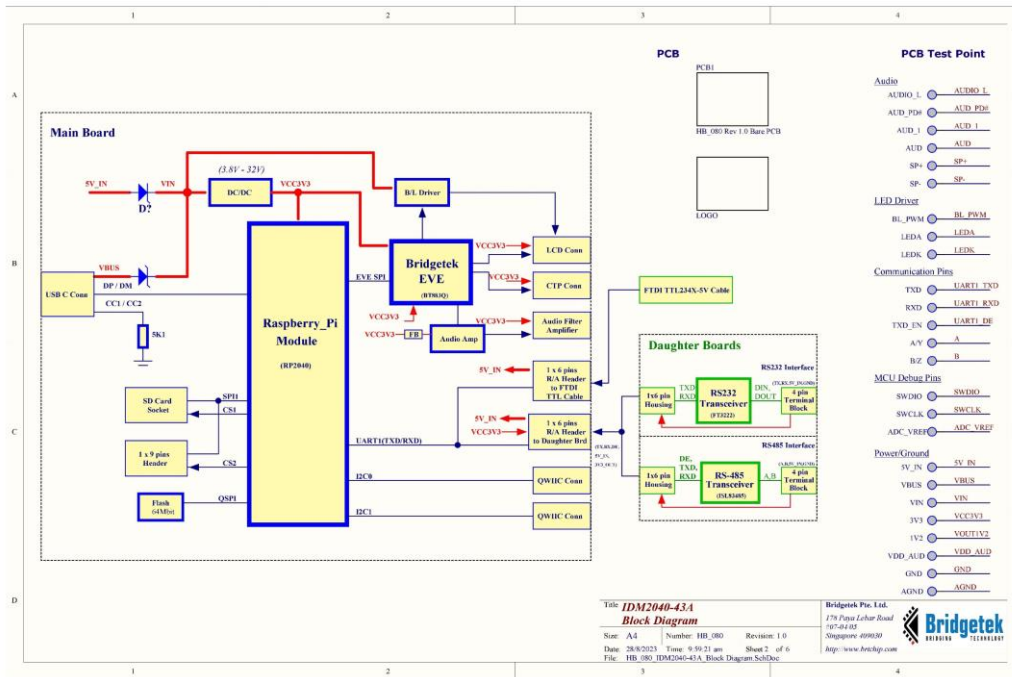

Figure 10 - IDM2040-43A Block Diagram

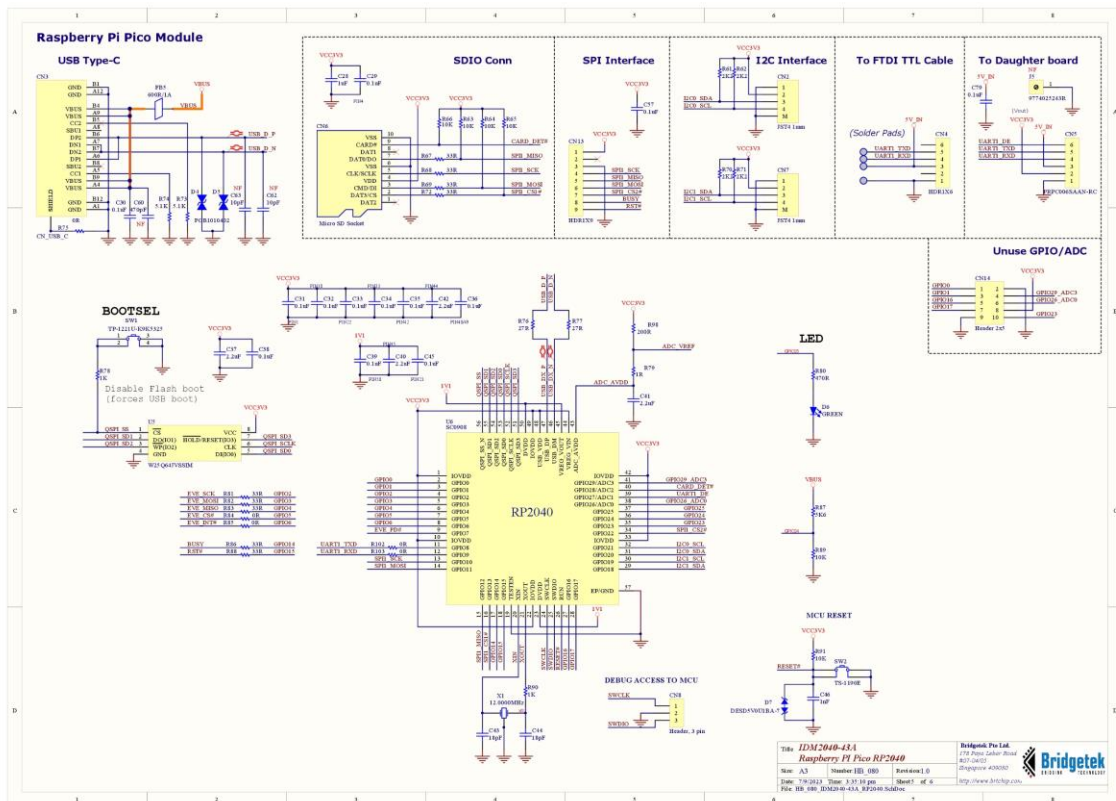

Figure 11 - RP2040 MCU Circuit

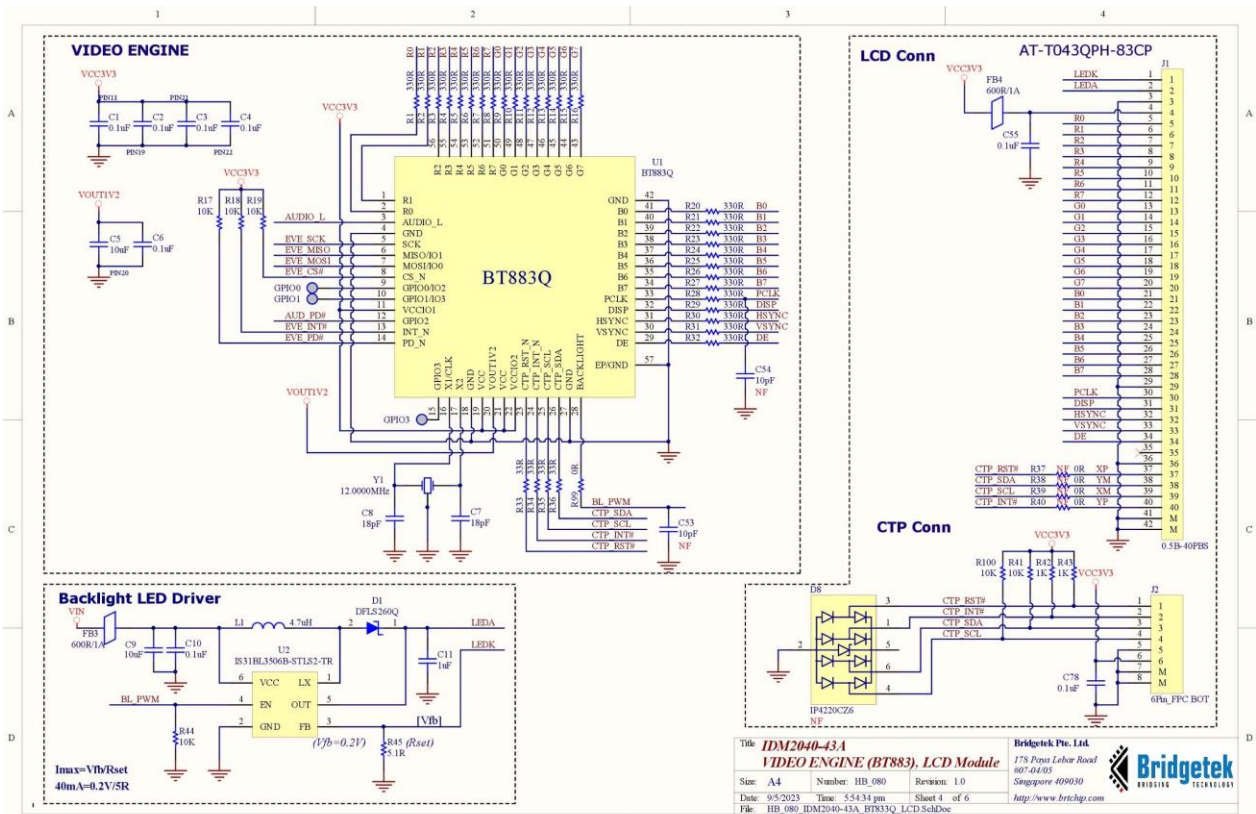

Figure 12 – BT883Q and LCD Circuit

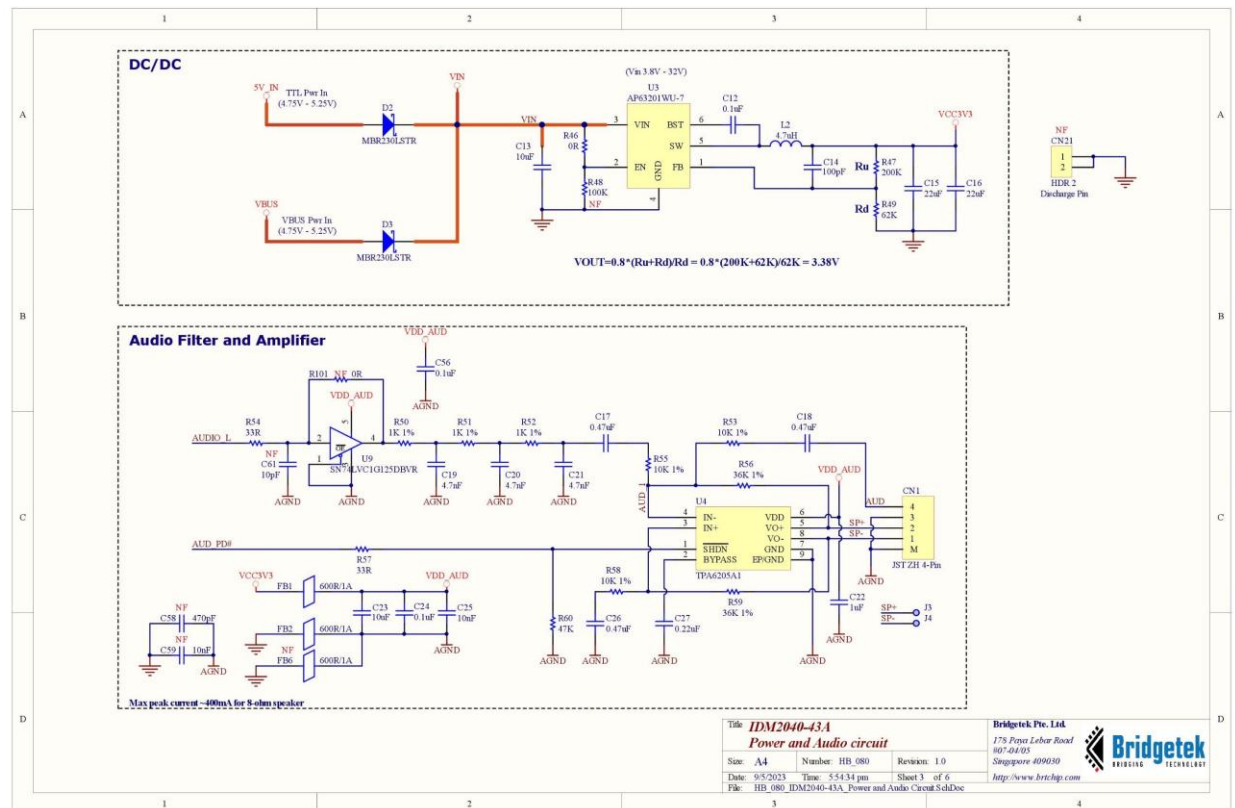

Figure 13 – Power and Audio Circuit

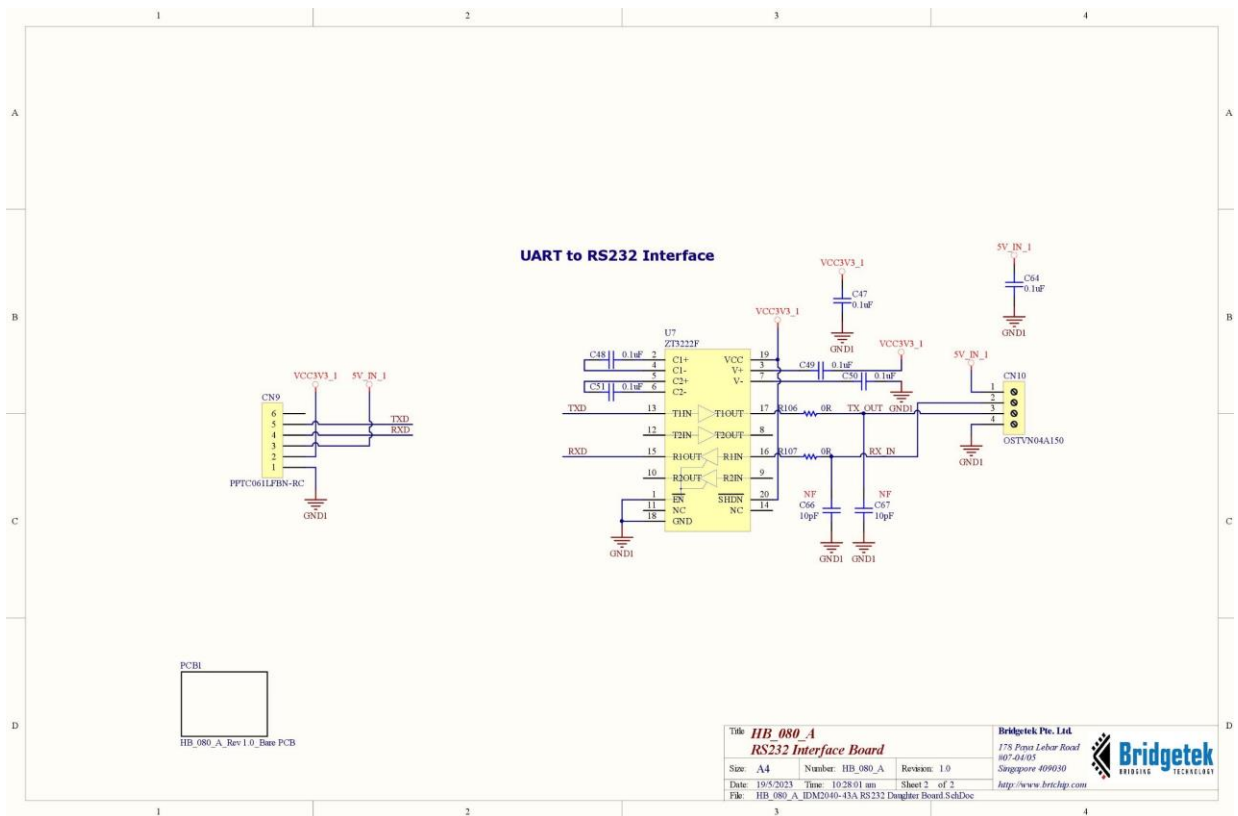

Figure 14 – RS232 Daughter Board Schematic

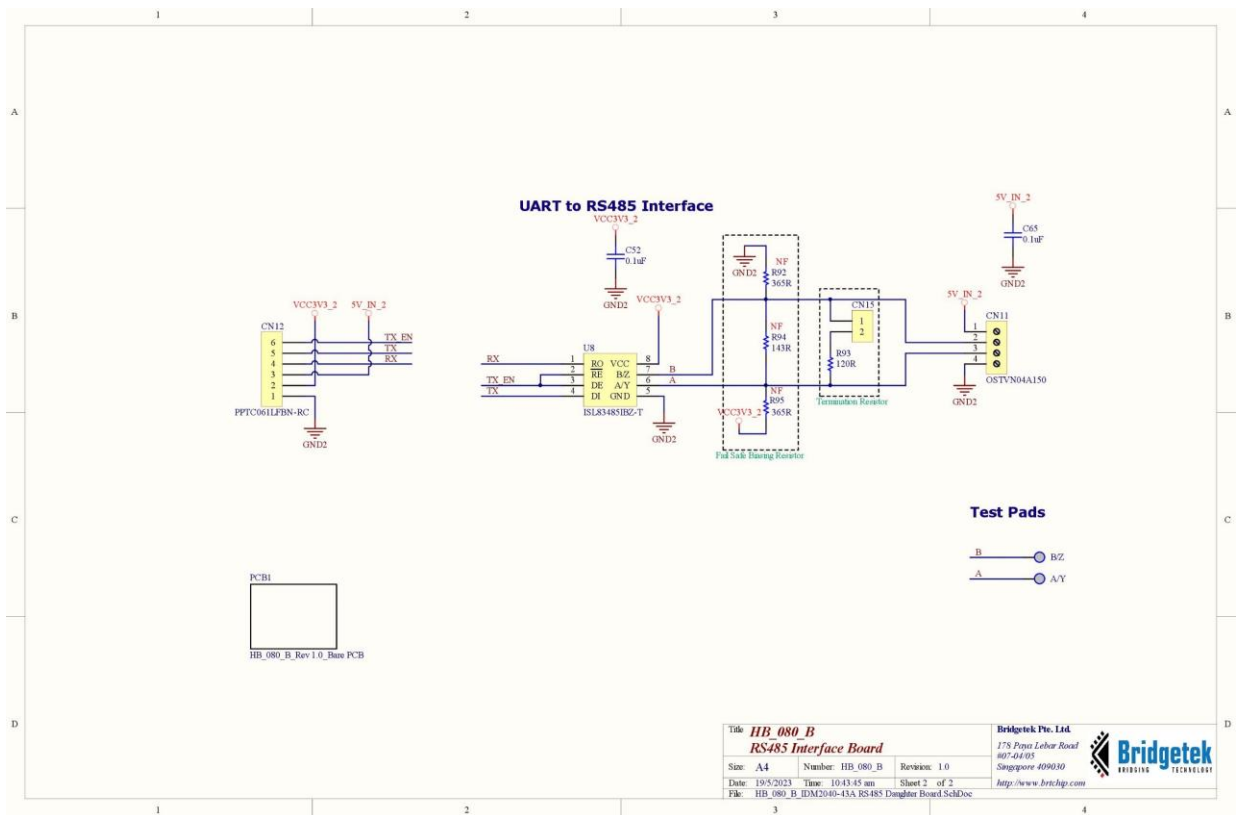
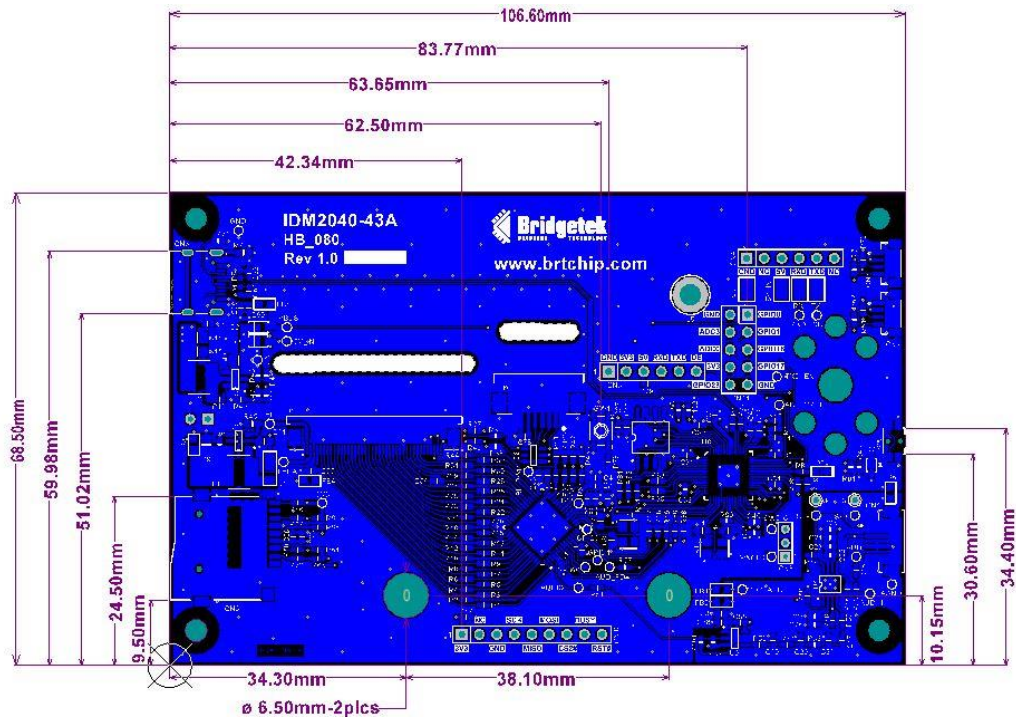

Figure 15 - RS485 Daughter Board Schematic

6 Mechanical Dimensions

6.1 IDM2040-43A PCBA Dimensions



6.2 IDM2040-43A Product Dimensions

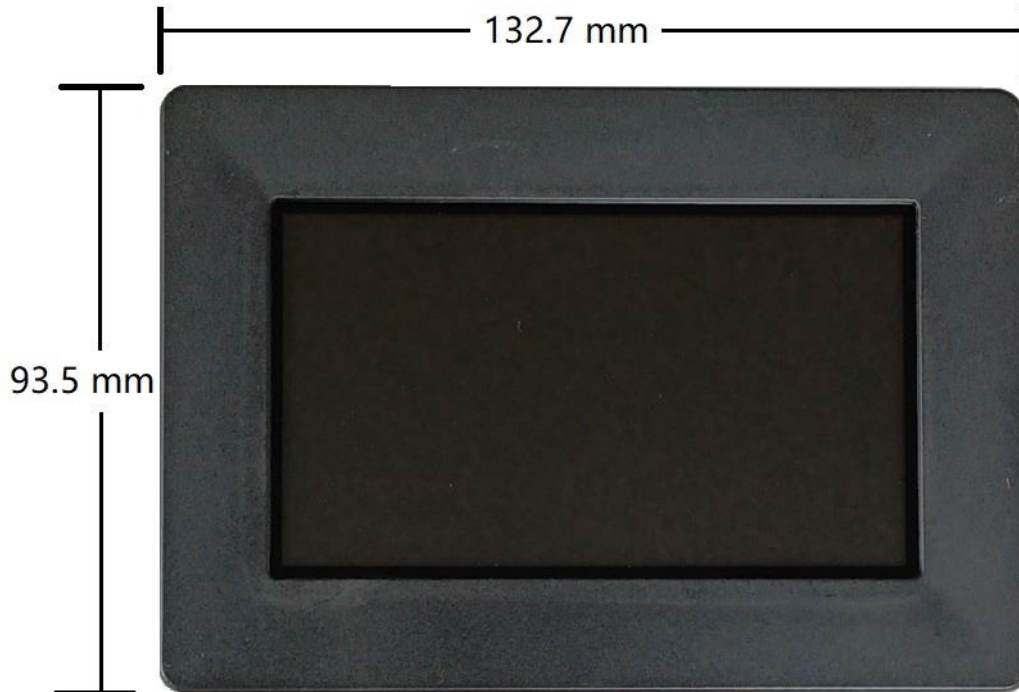

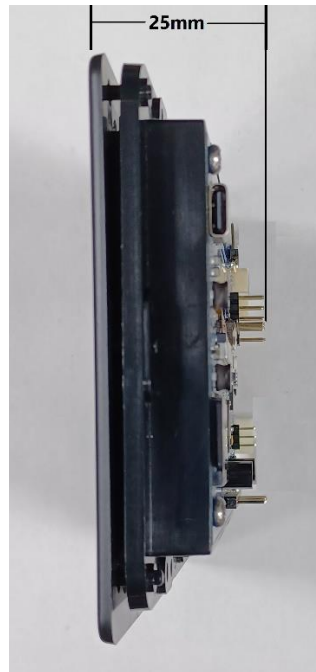

Figure 18 - IDM2040-43A Product Dimensions (Side View)

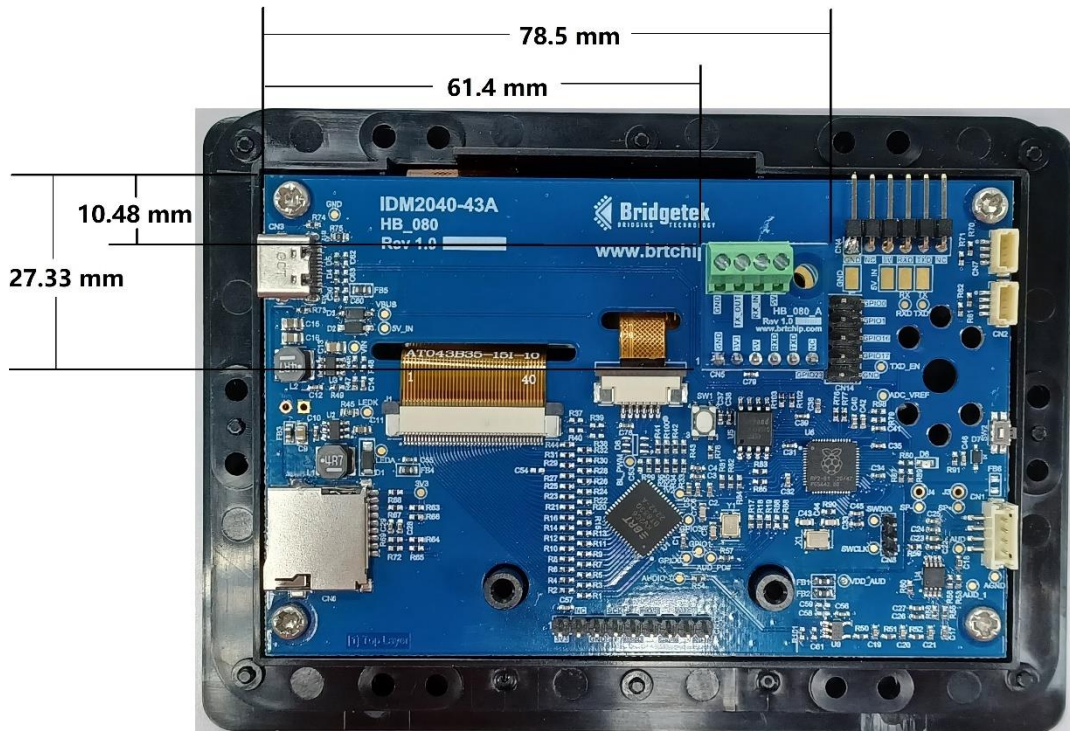

Figure 19 - IDM2040 Product Dimensions (Back View)

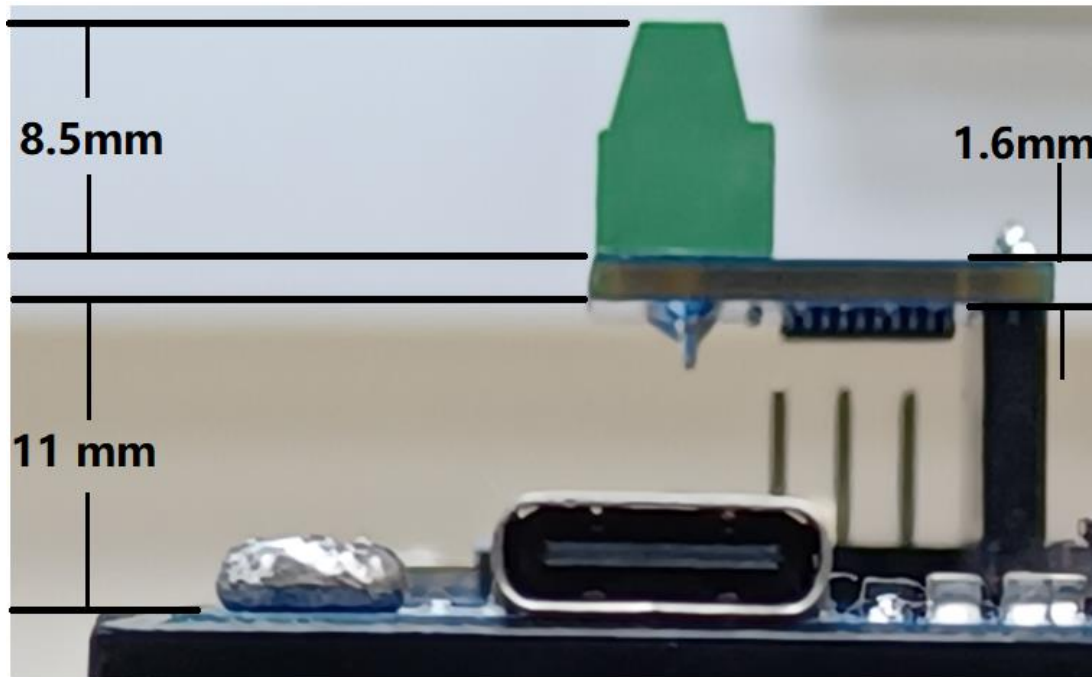

Figure 20 - Mating height between IDM2040-43A and IDM-RS232

6.3 IDM-RS232 PCBA Dimensions

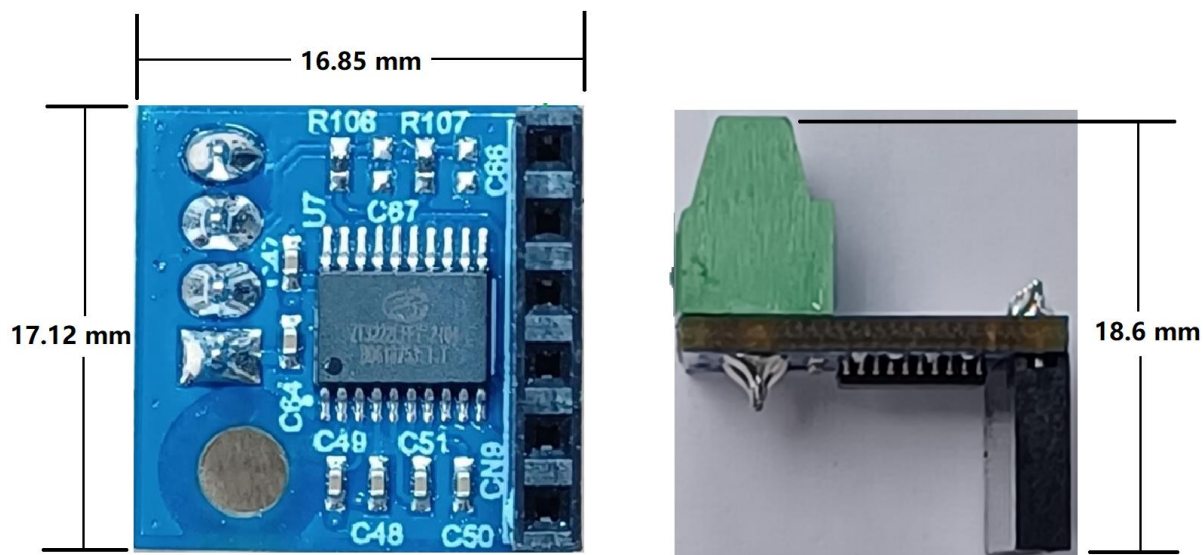

Figure 21 - IDM-RS232 PCBA dimensions

6.4 IDM-RS485 PCBA Dimensions

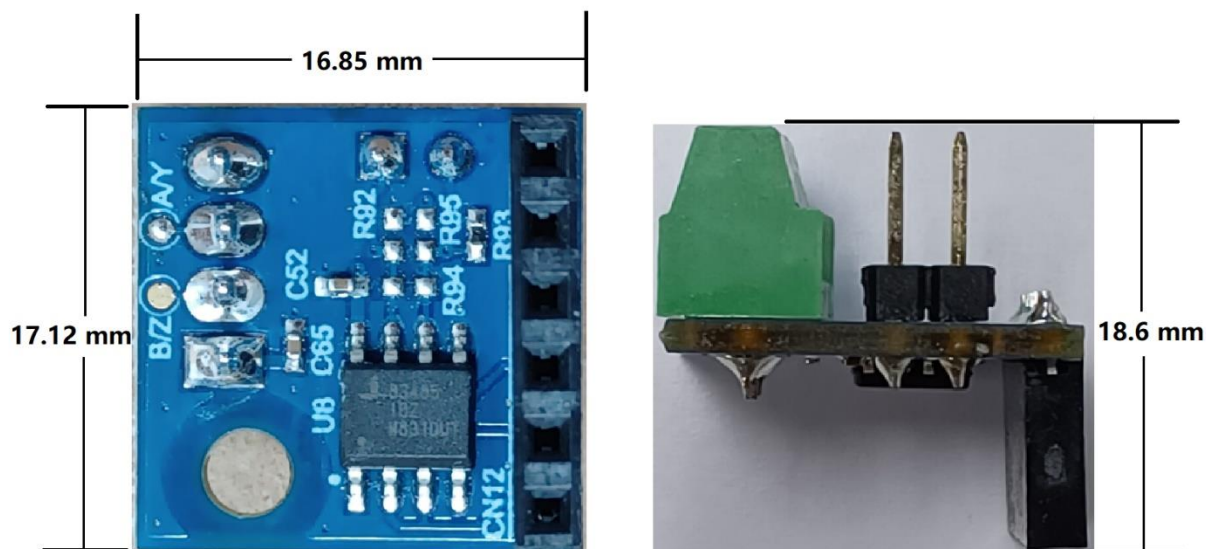

Figure 22 - IDM-RS485 PCBA dimensions

6.5 Assembling Bezel and Panel Mounting

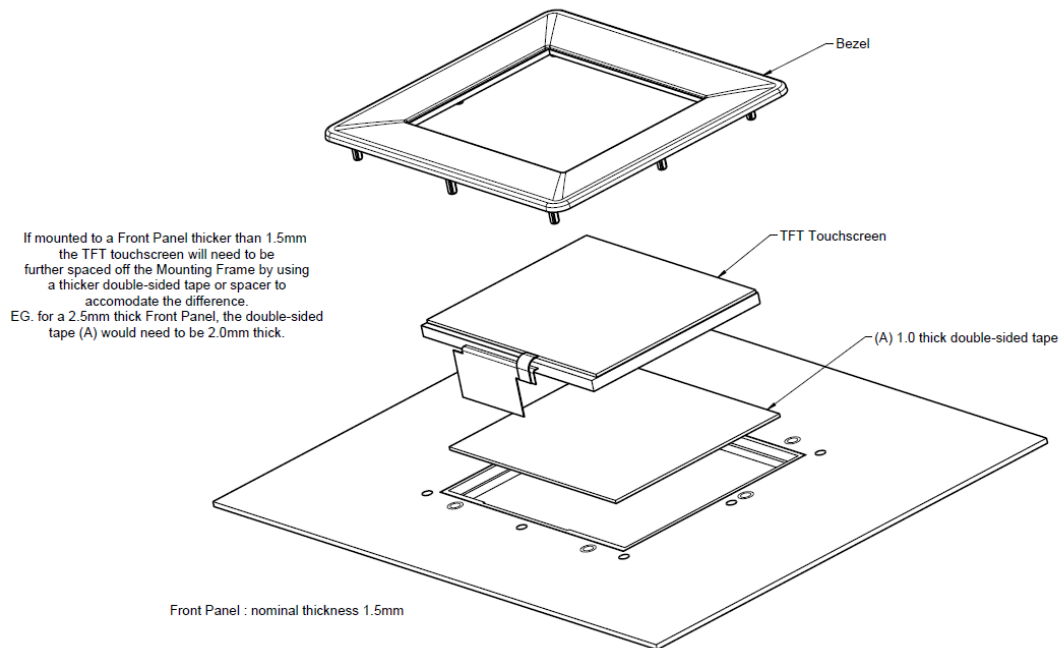

Figure 23 - IDM2040-43A Panel Mount (Front view)

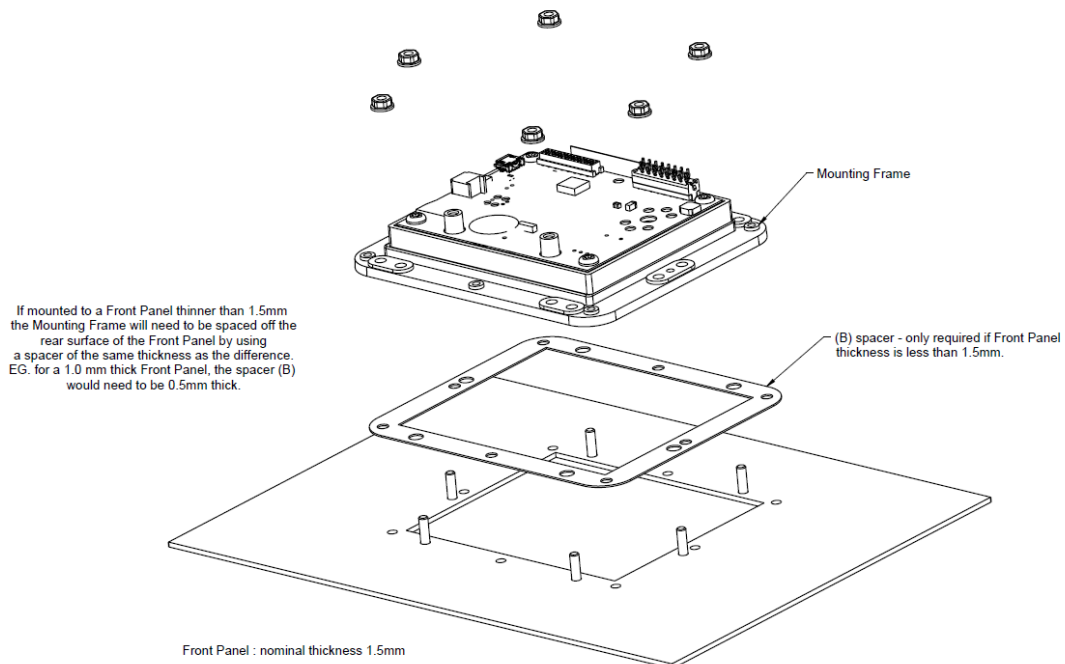
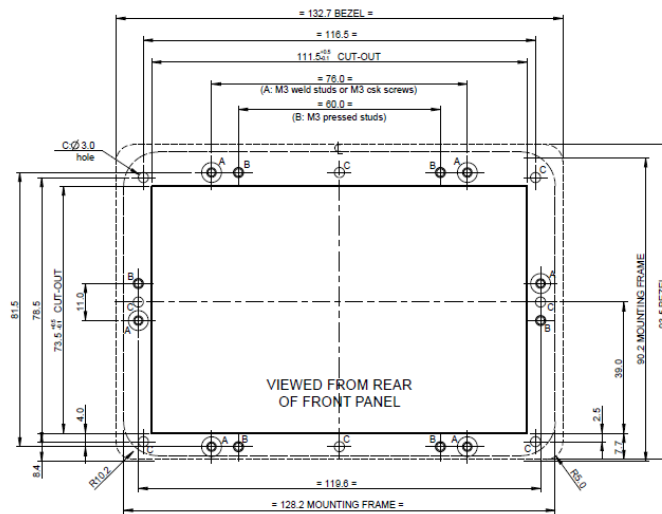

Figure 24 - IDM2040-43A Panel Mount (Rear View)

The TFT Touchscreen Mounting Frame is designed to mount to a 1.5mm thick Front Panel. If mounted to a Front Panel thicker than 1.5mm, longer mounting studs or screws should be used to accommodate the difference.

The Mounting Frame has been designed to work with projection welded studs or csk screws 'A' or press studs 'B'. For a 1.5mm thick Front Panel use -
M3 x 8 long weld studs,
M3 x 10 long countersunk screws or
M3 x 10 long pressed studs



When using countersunk screws to assemble the Mounting Frame, the screws should be located at the 'A' position

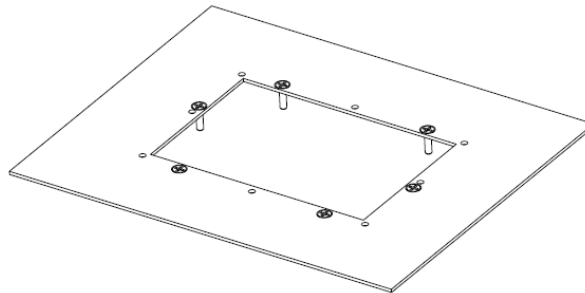

Figure 25 - IDM2040-43A Panel Mount Dimensions

7 Software Setup Information

- The RP2040 microcontroller can be programmed using C/C++, MicroPython or CircuitPython.

7.1 C/C++ SDK Setup

- For C/C++ development, the following programs need to be installed.
 - [Python 3.x](#)
 - [ARM GCC compiler](#)
 - [CMake](#)
 - [Build Tools for Visual Studio 2019](#) (C++ build tools only)
 - [Visual Studio Code](#)
 - [pico-sdk tools](#)
- It is recommended to download one package of all the above tools from [here](#) to install them.
- Raspberry Pi PICO/RP2040 C/C++ SDK document can be downloaded [here](#).
- Raspberry Pi PICO/RP2040 C/C++ examples can be downloaded [here](#).
- Raspberry Pi PICO/RP2040 C/C++ API Document is [here](#).
- Download and install latest EVE Screen Designer (ESD) from [here](#).
- Open ESD tools and run any example provided in the application.
- User needs to change the build target to IDM2040-43A via the toolbar button.
- User needs to build code to generate UF2 file.
- Push and hold SW1 BOOTSEL button on board while powering up the module by connecting CN3 to the computer using USB type C cable. Release BOOTSEL once the drive RPI-RP2 appears, drag and drop the UF2 file into the RPI-RP2 drive.

7.2 MicroPython SDK Setup

- Download the MicroPython UF2 file from [MicroPython](#).
- Push and hold SW1 BOOTSEL button on the board, then connect your computer using a type C USB cable. Release BOOTSEL once the drive RPI-RP2 appears on your computer
- Drag and drop the UF2 file into the RPI-RP2 drive. The RP2040 will reboot and will now run MicroPython.
- Download and install [Thonny](#) for your computer.
- Connect the board to your computer and in Thonny go to Tools>Options and click on the interpreter tab. From the interpreter dropdown list select MicroPython (Raspberry Pi PICO). Choose port "USB Serial Device (COMX)". Figure 20 shows the MicroPython with Thonny in ready status.



Figure 26 – MicroPython with Thonny in READY status

- Raspberry Pi PICO/RP2040 MicroPython SDK document can be downloaded from [here](#).
- Raspberry Pi PICO MicroPython examples can be downloaded from [here](#).
- Blink D2A example code is

```
from machine import Pin
import utime
led = Pin(25,Pin.OUT)
while True:
    led.value(1)
    utime.sleep(1)
    led.value(0)
    utime.sleep(1)
```

7.3 Circuitpython SDK Setup

- Download the CircuitPython UF2 file from [CircuitPython](#).
- Push and hold SW1 BOOTSEL button on the board, then connect your computer using a type C USB cable. Release BootSEL once the drive RPI-RP2 appears on the computer.
- Drag and drop the UF2 file into the RPI-RP2 drive. The RP2040 will reboot and the drive CIRCUITPY will appear.
- Download and install [Thonny](#) or [Mu](#) for your computer, recommend to install Mu editor for CircuitPython application.
- Connect the board to your computer and Run Mu, select RP2040, the MU with CircuitPython is ready to use.

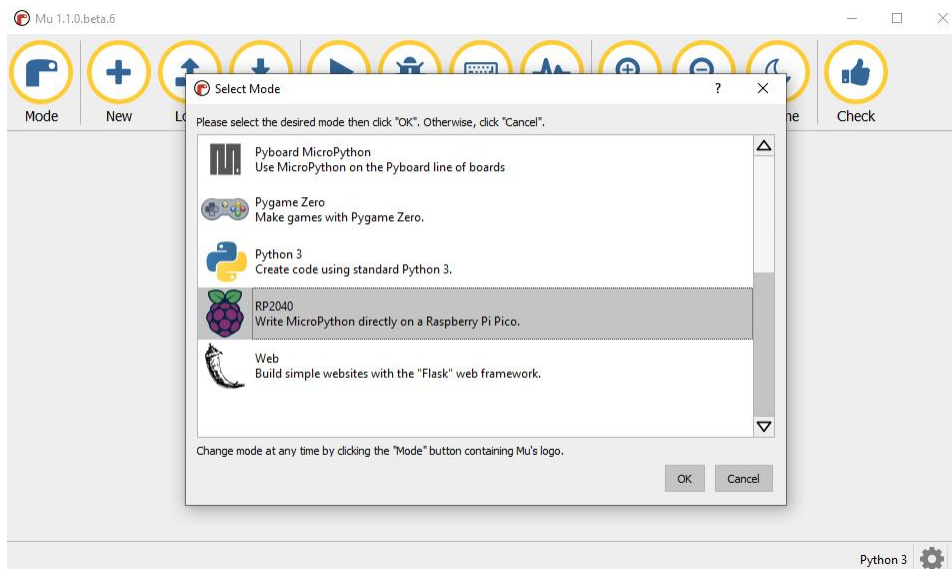
**Figure 27 – Install Mu Editor**

- Blink D2A example code is

```
import time
import board
import digitalio
led = digitalio.DigitalInOut(board.GP25)
led.direction = digitalio.Direction.OUTPUT
while True:
    led.value = True
    time.sleep(1)
    led.value = False
    time.sleep(1)
```

7.4 Bridgetek CircuitPython SDK Setup

- Below is the link which provides the sample code & libraries to run the EVE module in CircuitPython.
 - [pico-bteve github link](#)
- Visit BRT's website at <https://brtchip.com/eve/> for more information regarding the EVE module & its toolchain.

8 Disclaimer Notice: Use of Third-Party Software or Websites

We may recommend use of software or web sites that are owned or operated by other companies. We offer or facilitate this recommendation by hyperlinks or other methods to aid your access to the third-party resource. While we endeavour to direct you to helpful, trustworthy resources, we cannot endorse, approve, or guarantee software, information, products, or services provided by or at a third-party resource or track changes in the resource. Thus, we are not responsible for the content or accuracy of any third-party resource or for any loss or damage of any sort resulting from the use of, or for any failure of, products or services provided at or from a third-party resource.

We recommend these resources on an "as is" basis. When you use a third-party resource, you will be subject to its terms and licenses and no longer be protected by our privacy policy or security practices, which may differ from the third policy or practices or other terms. You should familiarize yourself with any license or use terms of, and the privacy policy and security practices of, the third-party resource, which will govern your use of that resource.

9 Contact Information

Refer to <https://brtchip.com/contact-us/> for contact information

Distributor and Sales Representatives

Please visit the Sales Network page of the [Bridgetek Web site](#) for the contact details of our distributor(s) and sales representative(s) in your country.

System and equipment manufacturers and designers are responsible to ensure that their systems, and any Bridgetek Pte Ltd (BRTChip) devices incorporated in their systems, meet all applicable safety, regulatory and system-level performance requirements. All application-related information in this document (including application descriptions, suggested Bridgetek devices and other materials) is provided for reference only. While Bridgetek has taken care to assure it is accurate, this information is subject to customer confirmation, and Bridgetek disclaims all liability for system designs and for any applications assistance provided by Bridgetek. Use of Bridgetek devices in life support and/or safety applications is entirely at the user's risk, and the user agrees to defend, indemnify and hold harmless Bridgetek from any and all damages, claims, suits or expense resulting from such use. This document is subject to change without notice. No freedom to use patents or other intellectual property rights is implied by the publication of this document. Neither the whole nor any part of the information contained in, or the product described in this document, may be adapted or reproduced in any material or electronic form without the prior written consent of the copyright holder. Bridgetek Pte Ltd, 1 Tai Seng Avenue, #03-05, Singapore 4536464. Singapore Registered Company Number: 201542387H.

Appendix A – References

Document References

[BT883 Datasheet](#)

[RP2040 Datasheet](#)

Acronyms and Abbreviations

Terms	Description
SIP	Single Inline Package
DFU	Device Firmware Update
PCBA	Printed Circuit Board Assembled
EVE	Embedded Video Engine
I2C	Inter-Integrated Circuit
MCU	Micro Controller Unit
PWM	Pulse Width Modulation
SPI	Serial Peripheral Interface
SWD	Serial Wire Debug
TTL	Transistor-transistor Logic
USB	Universal Serial Bus
UART	Universal Asynchronous Receiver-Transmitter

Appendix B – List of Tables & Figures

List of Tables

Table 1 – CN1 Pinout	9
Table 2 – CN2 & CN7 Pinout.....	9
Table 3 – CN4 Pinout	9
Table 4 – CN5 Pinout	10
Table 5 – CN8 Pinout	10
Table 6 – CN13 Pinout	10
Table 7 – CN14 Pinout	11
Table 8 - CN10 Pinout.....	13
Table 9 - CN9 Pinout.....	13
Table 10 - CN11 Pinout	14
Table 11 - CN12 Pinout.	14
Table 12 – Operating Voltage and Current	15
Table 13 – LCD and Touch Information	15
Table 14 – Optical Specifications	16

List of Figures

Figure 1 - IDM2040-43A Module - Front View.....	5
Figure 2 - IDM2040-43A Module - Back View	5
Figure 3 - IDM2040-43A PCBA - Front View	6
Figure 4 - IDM2040-43A PCBA – Back View	6
Figure 5 – Connectors and buttons on IDM2040-43A	8
Figure 6 – IDM-RS232 Daughter Board Mounting Orientation	12
Figure 7 – Connectors on IDM-RS232	12
Figure 8 – IDM-RS485 Daughter Board Mounting Orientation	13
Figure 9 - Connectors on IDM-RS485	14
Figure 10 - IDM2040-43A Block Diagram.....	17
Figure 11 - RP2040 MCU Circuit	17
Figure 12 – BT883Q and LCD Circuit	18
Figure 13 – Power and Audio Circuit	18
Figure 14 – RS232 Daughter Board Schematic	19
Figure 15 - RS485 Daughter Board Schematic.....	19
Figure 16 – IDM2040-43A PCBA Dimensions (Top View).....	20
Figure 17 - IDM2040-43A Product Dimensions (Front View)	20
Figure 18 - IDM2040-43A Product Dimensions (Side View)	21
Figure 19 - IDM2040 Product Dimensions (Back View)	21
Figure 20 - Mating height between IDM2040-43A and IDM-RS232	22

Figure 21 - IDM-RS232 PCBA dimensions	23
Figure 22 - IDM-RS485 PCBA dimensions	23
Figure 23 - IDM2040-43A Panel Mount (Front view).....	24
Figure 24 - IDM2040-43A Panel Mount (Rear View)	24
Figure 25 - IDM2040-43A Panel Mount Dimensions.....	25
Figure 26 – MicroPython with Thonny in READY status	27
Figure 27 – Install Mu Editor	28

Appendix C – Revision History

Document Title: IDM2040-43A Datasheet
Document Reference No.: BRT_000420
Clearance No.: BRT#203
Product Page: <https://brtchip.com/product-category/products/>
Document Feedback: [Send Feedback](#)

Revision	Changes	Date
Version 1.0	Initial Release	13-09-2023