

## Features

- 15" New Generation Stainless Steel Panel PC
- Intel Celeron J6412(2.0 GHz) Processor
- True Flat Front Bezel Design and Grade 304 Stainless Steel Enclosure (Grade 316 for option)
- IP66/IP69K Rated with M12 Connectors
- Support Resistive Touch and Projected Capacitive Touch
- Touch on/off Button on the Side Edge for Hygienic Cleaning
- Support Ergonomic Versatile Mounting: Yoke Mounting / Space-saving VESA 75 x 75 mm Mounting

## Specifications

System	
CPU	Onboard Intel Celeron J6412(2.0 GHz) Processor
System Chipset	SoC
Memory	1 x 260-pin SO-DIMM up to 32GB DDR4 3200MHz
TPM	TPM 2.0

IO Port	
USB	1 x M12 8-pin for USB 2.0 with waterproof cover and chain
Serial / Parallel	1 x M12 8-pin COM1, RS-232/422/485, default RS-232, with waterproof cover and chain
LAN	1 x M12 8-pin for LAN with waterproof cover and chain
Others	1 x Touch on/off button on the side
Power Connector	1 x M12 3-pin for DC power with waterproof cover and chain 1 x Power switch at the rear
Option	2 x optional blank M12 connector with waterproof cover and chain for selecting two from the following options: 2 x USB 2.0 1 x USB 3.0 1 x LAN (PoE for option) 1 x COM 1 x CAN

Storage Space	
HDD	1 x 2.5" SATA3 HDD
M.2	1 x M.2 B-Key(SATA 3), Support 2242 at default

Expansion	
Expansion slot	1 x M.2 E-Key 2230 socket (PCIe+USB) for optional Wi-Fi/BT(for option)
RFID module	RFID Module Design on the Front Side (for option)

Display	Standard	High Brightness Optional
Display Type	15" TFT-LCD	15" TFT-LCD
Max. Resolution	1024 x 768	1024 x 768
Max. Color	16.7M	262K / 16.2M (optional)
Luminance (cd/m <sup>2</sup> )	300	1000
View Angle	176(H) / 176(V)	160(H) / 160(V)
Contrast	2000:1	800:1
Backlight Lifetime	70,000 hrs	50,000 hrs

Touch Screen	
Type	Resistive Touch (For BR model) Projected Capacitive Touch (For BP model)
Interface	USB
Light Transmission(%)	Resistive Touch : 80% Projected Capacitive : 90%

## Dimensions

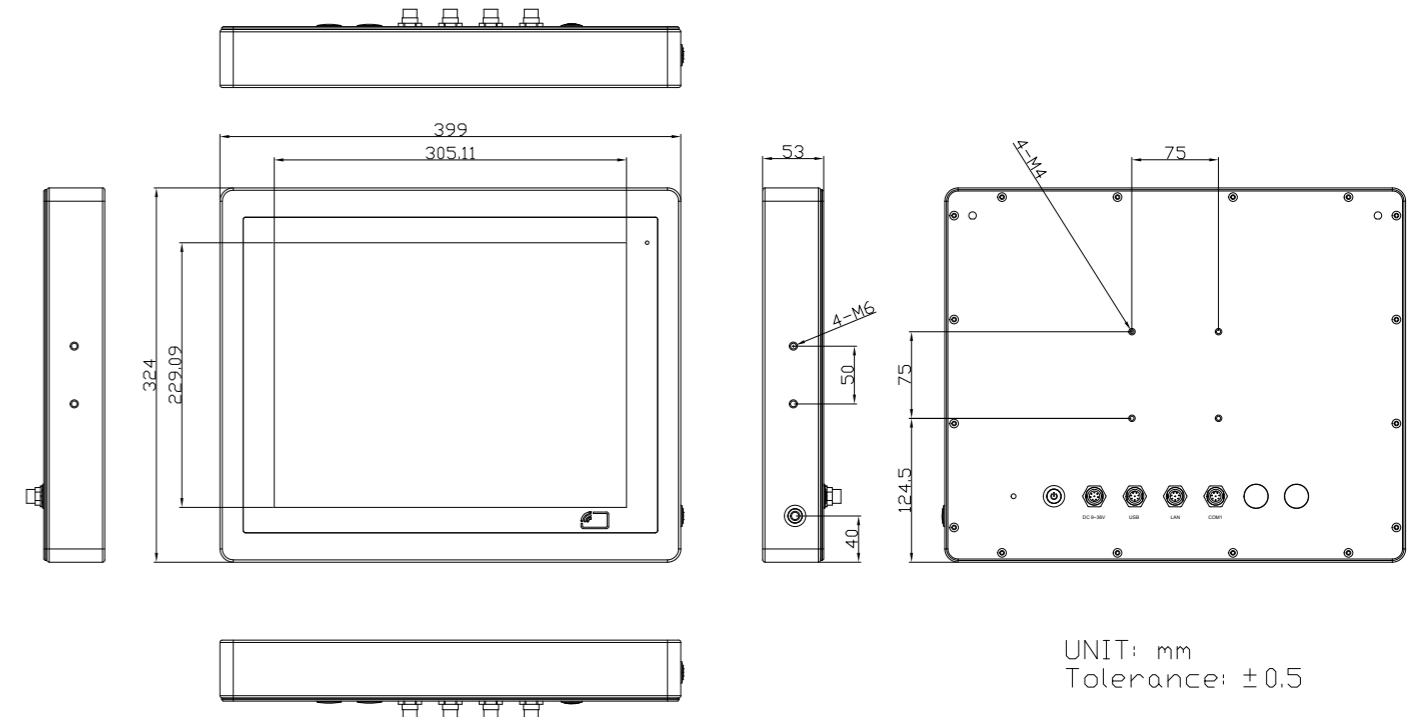

UNIT: mm  
Tolerance: ±0.5

Power	
Power Input	DC 9~36V
Power Consumption	ViTAM-815BP : TBD

Mechanical	
Construction	304 Stainless steel chassis(default), 316 Stainless steel chassis(optional)
Mounting	VESA mount 75 x 75, Yoke mount for optional
IP Rating	Total IP66/IP69K
Dimensions	399 x 324 x 53 mm
Net Weight	TBD

Environmental	
Operating Temperature	0~50°C / -20~60°C (option)
Storage Temperature	-30~70°C
Humidity	10 to 95% @ 40°C, non-condensing
Certificate	CE/FCC Class A

Operating System Support	
Windows	10 IoT ENT LTSB



Singel 3 | B-2550 Kontich | Belgium | Tel. +32 (0)3 458 30 33  
 info@alcom.be | www.alcom.be  
 Rivium 1e straat 52 | 2909 LE Capelle aan den IJssel | The Netherlands  
 Tel. +31 (0)10 288 25 00 | info@alcom.nl | www.alcom.nl