

VAULTIC408 1.x.x

Summary Datasheet

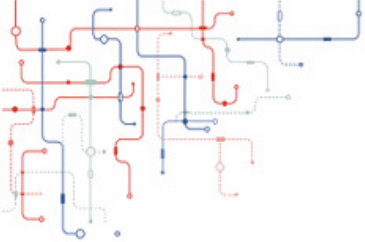

General Features

Cryptographic Services

- Strong generic challenge-response authentication protocol using digital signatures
- Digital Signature Generation / Verification
- Message Authentication Codes (MAC)
- Data encryption/decryption
- Key Agreement protocol
- Secure key transport with wrapping and unwrapping mechanisms
- Secure Communication Channel (MAC and encryption)
- One-Time Password Generation
- Message Digest
- On-chip public key pair generation
- NIST SP 800-90 Deterministic Random Bit Generator using AES-256 algorithm
- Strong authentication and secure communications for chip administration operations
- Secure data storage in dynamic file system
- Identity-based authentication and advanced access conditions

Cryptographic Algorithms

- AES 128/192/256 bits
- GCM / GMAC
- RSA[®] up to 2048 bits
- ECC up to 576 bits over GF(p) and GF(2^m)

Software Features

- FIPS 140-3 Identity-based authentication using password, Strong Authentication with Secure Channel Protocol (SCP03)
- Rights Management (Administrator, Approved User, Non-approved User...)
- Embedded Dynamic File System

Communication

- Slave SPI, WISeKey's Proprietary Protocol
- I²C (Two Wire Interface), WISeKey's Proprietary Protocol

Memory

- Up to 16Kb dedicated to the File System
 - EEPROM Data Retention : up to 50 Years
 - Endurance : 500.000 write/erase cycles at 25°C
 - Endurance : 200.000 write/erase cycles at 105°C
 - 7-Slot ephemeral Key Ring

Package

- SOIC8 (RoHS compliant) 5mm x 8mm
- QFN20 (RoHS compliant) 4mm x 4mm

Hardware Platform

- 8-/16-bit RISC CPU
- Hardware Random Number Generator
- Hardware AES 128/192/256 Engine DPA/DEMA Resistant
- Hardware 32-bit Public Key Crypto Co-Processor
- CRC 16 & 32 Engine (Compliant with ISO / IEC 3309)

Security

- Dedicated Hardware for Protection Against SPA/DPA/SEMA/DEMA Attacks
- Advanced Protection Against Physical Attack, including Active Shield, Enhanced Protection Object, CStack Checker, Slope Detector, Parity Errors (ROM, RAM)
- Environmental Protection Systems
- Voltage Monitor
- Frequency Monitor
- Temperature Monitor
- Light Protection
- Code Signature Module

Certifications / Standards

- Hardware is EAL5+ Ready
- VaultIC408 1.1.x : NIST FIPS 140-3 ACVP + ESV
- VaultIC408 1.2.x : NIST FIPS 140-3 Level 3 CMVP



1. Overview

The VaultIC408 1.x.x is a secure microcontroller-based solution designed to secure various systems against counterfeiting, cloning or identity theft. It is a hardware security module that can be used in many applications such as IP protection, access control, IoT or hardware protection.

The proven technology used in VaultIC408 1.x.x security modules is already widespread and used in national ID/health cards, e-passports, bank cards (storing user Personal Identification Number, account numbers and authentication keys among others), pay-TV access control and cell phone SIM cards (allowing the storage of subscribers' unique ID, PIN code, and authentication to the network), where cloning must definitely be prevented.

Strong Authentication capability, secure storage and flexibility thanks to the various interfaces (SPI, I²C), low pin count and low power consumption are main features of the VaultIC408 1.x.x. Its embedded firmware provides advanced functions such as Role-based access control, large Cryptographic command set, various Public domain cryptographic algorithms, Cryptographic protocols, Secure Channel Protocols, Robust communication protocol.

From the VaultIC408 1.1.x, a compatibility mode is embedded to be compatible with the VaultIC405 1.2.1 and VaultIC405 1.2.5.

1.1 Tamper resistance

WISeKey's security modules will advantageously replace complex and expensive proprietary anti-tampering protection system. Their advantages include low cost, ease of integration, higher security and proven technology.

They are designed to keep contents secure and avoid leaking information during code execution. While on regular microcontrollers, measuring current consumption, electromagnetic emissions and other side channels may give precious information on the processed data or allow the manipulation of the data. WISeKey's secure microcontrollers' security features include voltage, frequency and temperature detectors, illegal code execution prevention, tampering monitors and protection against side channel attacks and probing. The chips can detect tampering attempts and erase sensitive data on such events, thus avoiding data confidentiality being compromised.

These features make cryptographic computations secure in comparison with regular microcontrollers whose memories can be easily duplicated. It is much safer to delegate cryptographic operations and storage of secret data (keys, identifiers, etc.) to a WISeKey microcontroller.



1.2 Authentication capability

The methods to authenticate humans are generally classified into three cases: physical attribute (e.g. fingerprint, retinal pattern, facial scan, etc.), security device (e.g. ID card, security token, software token or cell phone) and something the user knows (e.g. a password/passphrase or a personal identification number).

To fight against identity theft, the multi-factor authentication is a stronger alternative to the classical login/password authentication (called weak authentication). It combines two or more authentication methods (often a password combined with a security token). Two-factor systems greatly reduce the likelihood of fraud by requiring the presence of a physical device used together with a password. If the physical device is lost or the password is compromised, security is still intact. NIST's authentication guideline can be referred to for further details.

Multi-factor authentication requires a strong authentication. Anticlone is safely implemented through one-way or mutual strong authentication. Various authentication protocols exist (as specified in ISO9798-2 or FIPS196), but the main method is the **challenge-response authentication**:

1. The authenticator sends a challenge (e.g. a random number) to the equipment that must be authenticated ("the claimant").
2. The claimant computes a digital signature of the combination of this challenge with an optional identifier, using a private or secret key. The requested signature is then returned to the authenticator.
3. The authenticator checks the signature using either the same secret key or the public key associated to the claimant's private key and decides whether the claimant is authorized or not based on the signature verification result.

This strong authentication method requires storing secret data. Pure software multi-factor solutions are thus not reliable.

1.3 Secure storage

If sensitive data is stored in files on a hard disk, even if those files are encrypted, the files can be stolen, cloned and subjected to various kinds of attacks (e.g. brute force or dictionary attack on passwords). Therefore secure microcontroller-based hardware tokens are a must. Placing secrets outside the computer avoids risking exposure to malicious software, security breaches in web browsers, files stealing, etc.

1.4 Flexibility

The VaultIC408 1.x.x product features:

- Various **communication interfaces** including SPI (Serial Peripheral Interface) and I²C (Two Wire Interface) .
- **Low pin count** (Vcc, GND and communication interface specific pins) making integration into an existing board simple. VaultIC408 1.x.x modules are available in small package (SOIC8) to fit into the most size-constrained devices.
- **Low power consumption**, in order to extend battery life in portable devices and low-power systems. VaultIC408 1.x.x devices consume less than 300µA in standby mode, and only 10 to 20mA (see [Table 3-2](#)) during CPU-intensive operations depending on the required action.



- **Embedded firmware** that provides advanced functions:
 - *Secure storage*: a fully user-defined non-volatile storage of **16KBytes** for sensitive or secret data.
 - *Role-based access control* with user, administrator and manufacturer roles supported.
 - *Cryptographic command set* to perform cryptographic operations using keys and data from the file system including: authentication, digital signature, encryption/decryption, hash, one-time password generation, random generation and public key pair generation.
 - *Public domain cryptographic algorithms* such as AES, RSA PKCS#1 v2.1, ECDSA, MAC using AES
 - *Cryptographic protocols* such as secret-key unilateral or mutual authentication and public key based unilateral or mutual authentication .
 - *Secure Channel Protocol* using AES and key agreement.
 - *Robust communication protocol* stacked over the physical communication interfaces.

1.5 Ordering Information

1.5.1 Legal

A **Non-Disclosure Agreement** must be signed with WISeKey.

1.5.2 Quotation and Volume

For minimum order quantity and the annual volume, please contact your local WISeKey sales office.

1.5.3 Part Number

Reference		Description
VAULTIC408-xxx-P		xxx : Chip "Chrono" Number* P =R : SOIC8 Package Z : QFN20 Package
Reference	Application	Description
VAULTIC-STK22-408R-L	Embedded Security	Starter Kit for VaultIC408 in SOIC8 Legacy package - SPI/I ² C configuration
VAULTIC-STK22-408R	Embedded Security	Starter Kit for VaultIC408 in SOIC8 package - SPI/I ² C configuration
VAULTIC-STK22-408Z	Embedded Security	Starter Kit for VaultIC408 1.x.x in QFN20 package - SPI/I ² C configuration

* For more details about the Chip "Chrono" Number, please contact your local WISeKey sales office.



Caution

The "Legacy" package is pin to pin compatible with the VaultIC405.

It does NOT feature a RST input.

It is recommended to not use this variant for new design.

1.5.4 Starter Kit

The VaultIC408 1.x.x Starter Kit provides an easy path to master the cryptographic and secure data storage features of the VaultIC408 1.x.x secure elements. The content is :

- VaultIC408 1.x.x samples with 1 dedicated test socket
- 1 USB key containing a support documentation set (getting started, application notes, reference design), some demo applications to get an insight into the VaultIC4xx features, the "VaultIC Manager" tool to design the file system and to personalize samples, a hardware independent cryptographic API with source code, libraries.

Figure 1-1. Starter Kit VaultIC408 1.x.x - Example of content

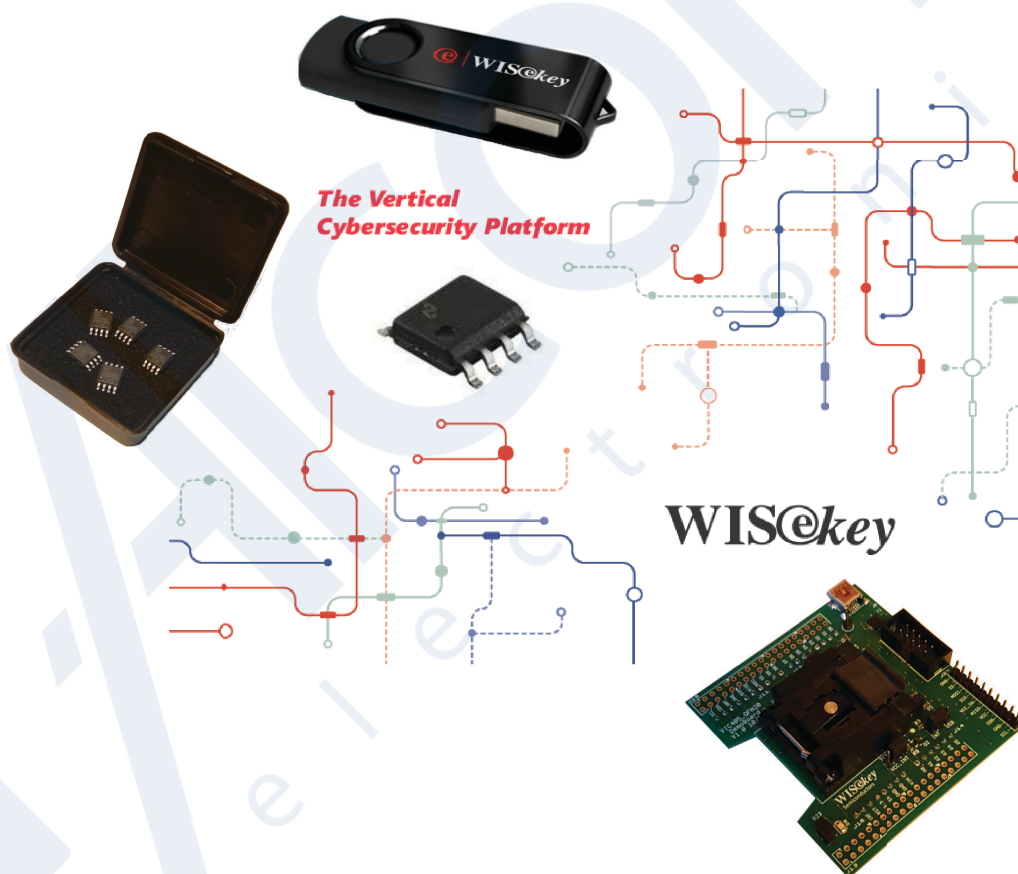

1.6 Software and Hardware Architecture

The VaultIC408 1.x.x software architecture is as shown on the diagram below.

Figure 1-2. Software and Hardware Architecture

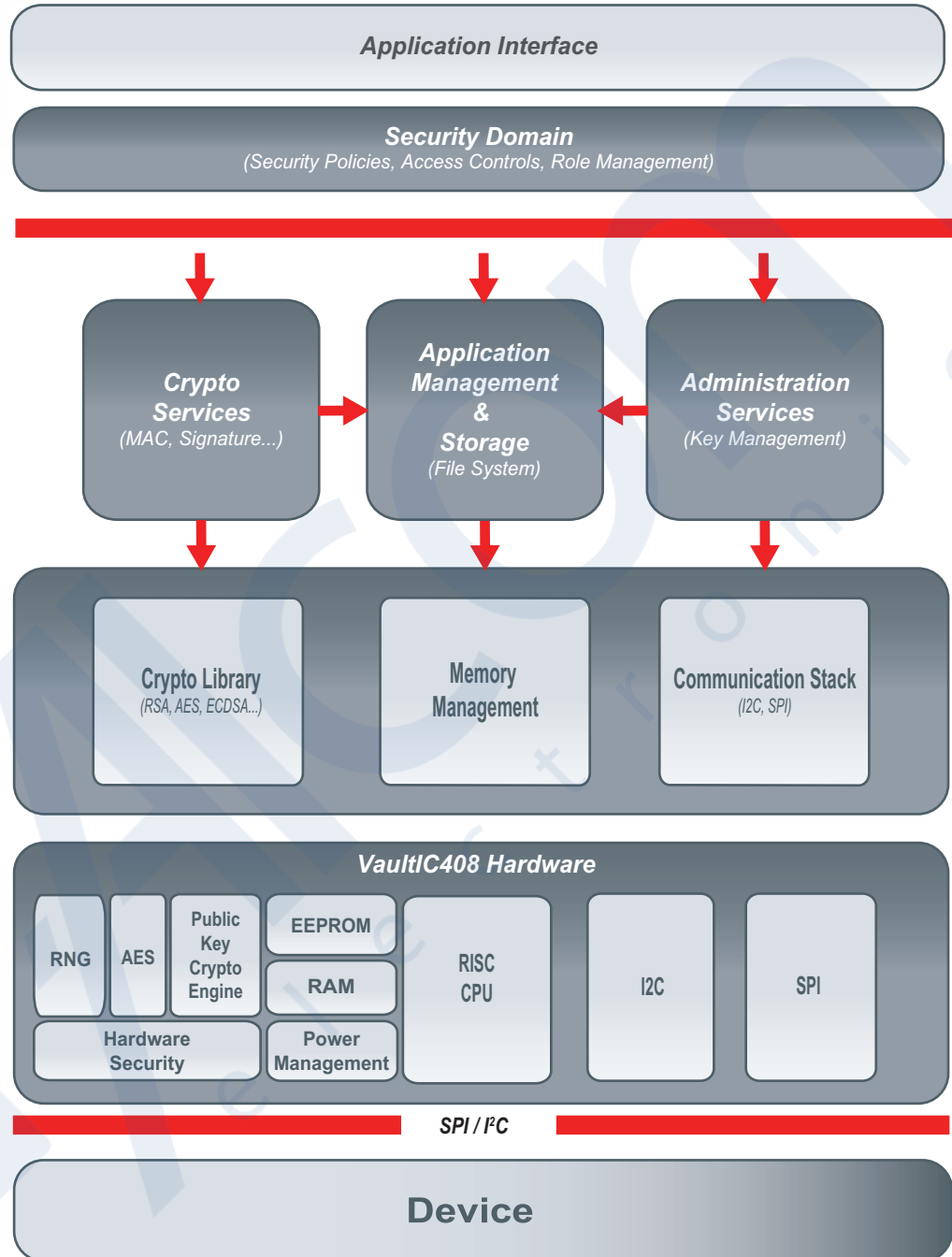



2. Detailed Features

2.1 Communication Interfaces

The VaultIC408 1.x.x embeds the following communication interfaces:

- **SPI**: up to 11 Mbps
- **I²C** : up to 400 kbps

2.2 Security Mechanisms

The table below summarizes the cryptographic algorithms supported by the VaultIC408 1.x.x.



Please refer to the document *VaultIC408 1.x.x Technical Datasheet* (Available under Non-Disclosure Agreement only) for more details.

Table 2-1. Supported Algorithms table

Cryptographic Services	Supported Algorithms
Strong Authentication	<ul style="list-style-type: none"> • Password authentication • Secure password authentication
	Generic challenge-response authentication protocol using digital signatures <ul style="list-style-type: none"> • ISO/IEC 9798-2 • FIPS 196 • Global Platform v2.2 SCP03 using AES
Public Key-Pair Generation	<ul style="list-style-type: none"> • PKCS#1.5 RSA keypair generator • ANSI X9.62 ECDSA keypair generator
MAC (Message Authentication Codes)	<ul style="list-style-type: none"> • NIST SP 800-38B AES CMAC • NIST SP 800-38D AES GMAC • FIPS 198 HMAC with SHA-1, SHA-224, SHA-256, SHA-384 or SHA-512
Message Signature	<ul style="list-style-type: none"> • PKCS#1 v2.1 RSASSA PSS • PKCS#1 v2.1 RSASSA-PKCS1-v1_5 • Raw RSA X.509 with no padding • ANSI X9.62 ECDSA over GF(p) and GF(2^m) • ECDSA-GBCS



Cryptographic Services	Supported Algorithms
Message Encryption	Data encryption / decryption: <ul style="list-style-type: none"> • AES • PKCS#1 v2.1 RSAES-OAEP • PKCS#1 v2.1 RSAES-PKCS1-v1.5 • Raw RSA X509 with no padding • NIST SP800-38D GCM • NIST SP800-38F AES-based key wrapping Block chaining modes: <ul style="list-style-type: none"> • ECB • CBC • OFB • CFB • CTR Padding methods: <ul style="list-style-type: none"> • No padding • Method 1 • Method 2 • PKCS 5 • PKCS 7
HOTP - One-Time Password Generation	<ul style="list-style-type: none"> • OATH Hash-based OTP algorithm (RFC 4226)
Message Digest	<ul style="list-style-type: none"> • SHA-1 • SHA-224 • SHA-256 • SHA-384 • SHA-512
Random Number Generation	<ul style="list-style-type: none"> • NIST SP 800-90 Deterministic Random Bit Generator using CTR-AES-256 algorithm
Key Transport Scheme	<ul style="list-style-type: none"> • NIST SP800-56B Key Transport Scheme based on RSAES-OAEP without key confirmation • NIST SP800-38F Transport Scheme based on AES • NIST SP800-38F Transport Scheme based on AES compatible with TIA-102.AACA • Generic Transport Scheme based on AES
Key Agreement Protocol	Key agreement schemes based on Elliptic Curves featuring in accordance with: <ul style="list-style-type: none"> • ANSI X9.63 • NIST SP800 56Ar2 • BSI-TR-03111



Cryptographic Services	Supported Algorithms
Key Establishment Primitives	<ul style="list-style-type: none">• ECC_DH according to ANSI X9.63• ECC_CDH according to ANSI X9.63 and NIST SP800 56Ar2• ECKA according to BSI-TR-03111
Key Derivation Function	<ul style="list-style-type: none">• KDF_CONCATENATION according to NIST SP800 56Ar2• KDF_X963 according to ANSI X9.63• KDF_HASH according to Microsoft Smart Card Minidriver specification
Key Confirmation	Supported by Key Agreement Protocol in FIPS mode

3. Product Characteristics

3.1 Maximum Ratings

Table 3-1. Absolute Maximum Ratings

Symbol	Parameter	Min.	Max.	Units
V _{CC}	Supply Voltage	0	7.5	V
T _A	Operating Temperature	-40	+105	°C
E _{EEPROM}	EEPROM Endurance for write/erase cycles		500 000 ⁽¹⁾	cycles
t _{DataRetention}	EEPROM Data Retention		50 ⁽²⁾	Years
ESD	Electrostatic Discharge		4(HBM) 1(CDM)	kV
Lup	Latch-up		+/- 200	mA

1. At a temperature of 25°C.
2. Failure rate <1 ppm at a temperature of 25°C



Caution

Stresses beyond those listed under “Absolute Maximum Ratings” may cause permanent damage to the device. This is a stress rating only and functional operation of the device at these or other conditions beyond those indicated in the operational sections of this specification is not implied. Exposure to absolute maximum rating conditions for extended periods may affect device reliability.

3.2 AC/DC Characteristics (1.62V - 5.5V range; T= -40°C to +105°C)

Table 3-2. AC/DC Characteristics (1.62V - 5.5V range; T= -40°C to +105°C)

Symbol	Parameter	Condition	Min.	Typ.	Max.	Units
V _{CC}	Supply Voltage		1.62		5.5	V
V _{IH}	Input High Voltage - SPI_MISO, SPI_MOSI, SPI_SCK, SPI_SEL, SPI_SS, GPIOs		0.7*V _{CC}		V _{CC} +0.3	V
V _{IL}	Input Low Voltage - SPI_MISO, SPI_MOSI, SPI_SCK, SPI_SEL, SPI_SS, GPIOs		-0.3		0.2*V _{CC}	V
I _{IH}	Leakage High Current - SPI_MISO, SPI_MOSI, SPI_SCK, SPI_SEL, SPI_SS, GPIOs	V _{IN} = V _{IH}	-10		10	µA
I _{IL}	Leakage Low Current - SPI_MISO, SPI_MOSI, SPI_SCK, SPI_SEL, SPI_SS, GPIOs	V _{IN} = V _{IH}	-40		10	µA
V _{OL}	Output Low Voltage - SPI_MISO, SPI_MOSI, SPI_SCK, SPI_SS, GPIOs	I _{OL} = 1mA	0		0.1*V _{CC}	V
V _{OH}	Output High Voltage - SPI_MISO, SPI_MOSI, SPI_SCK, SPI_SS, GPIOs	I _{OH} = 1mA	0.7*V _{CC}		V _{CC}	V
R _{I/O}	Pin Pull-up SPI_SEL, SPI_SS			220		KΩ
R _{RST}	Pin Pull-up RST			200		KΩ
I _{CC LwPw}	Supply Current in Low Power	5.0V (+/- 10%) 3.0V (+/- 10%) 1.8V (+/- 10%)		70 63 59		µA
I _{CC RunPeriph}	Supply Current in RUN mode during RSA/ECC authentication				21	mA

6655CS - 23Sep22



Table 3-3. AC/DC Characteristics (1.62V - 5.5V range; T= -40°C to +105°C)

Symbol	Parameter	Condition	Min.	Typ.	Max.	Units
T _r	I/O Output Rise Time (HRD Mode)	C _{out} =30pF R _{pullup} =20kΩ 3V		6		ns
		C _{out} =30pF R _{pullup} =20kΩ 5V		4		ns
T _f	I/O Output Fall Time	C _{out} =30pF R _{pullup} =20kΩ 3V		3.7		ns
		C _{out} =30pF R _{pullup} =20kΩ 5V		3.2		ns



Caution

The values given in [Table 3-1](#), [Table 3-2](#) and [Table 3-3](#) are targeted preliminary values that cannot be guaranteed until a full characterization of the product has been made.

3.3 Timings

3.3.1 I²C Timings

The table below describes the requirements for devices connected to the I²C Bus. The VaultIC408 1.x.x I²C Interface meets or exceeds these requirements under the noted conditions.

Timing symbols refer to [Figure 3-1](#).

Table 3-4. I²C Timings Parameters

Symbol	Parameter	Condition	Min.	Max.	Units
f _{SCL}	SCL Clock Frequency			400	kbps
t _{SU;STA}	Set-Up Time for a (repeated) START Condition		70		ns
t _{HD;STA}	Hold Time (repeated) START Condition	After this period, the first clock pulse is generated	70		ns
t _{LOW}	Low Period of the SCL Clock		490		ns
t _{HIGH}	High period of the SCL clock		130		ns
t _{HD;DAT}	Data hold time		40		ns
t _{SU;DAT}	Data setup time		50		ns
t _{SU;STO}	Setup time for STOP condition		70		ns
t _{BUF}	Bus free time between a STOP and a START condition		1.3		μs



Figure 3-1. I²C Timings chronograms

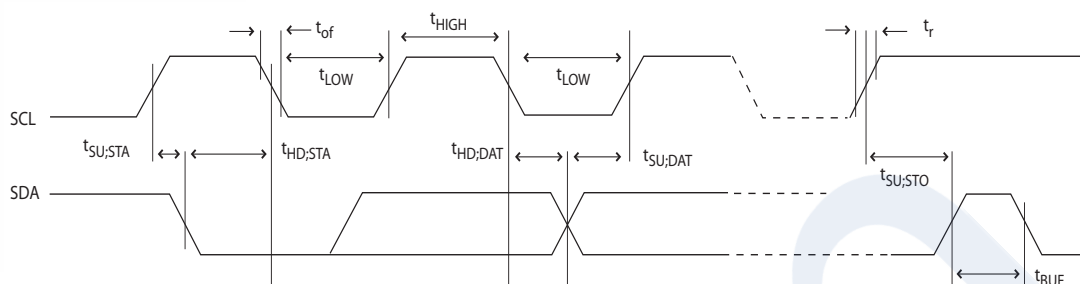

Parameters t_{of} and t_r depend on the Host.



These timings refer to Hardware communication parameters. For protocol timings, please refer to the document *VaultIC408 1.x.x Technical Datasheet*.

3.3.2 SPI Timings

The table below describes the requirements for devices connected to the SPI. The VaultIC408 1.x.x SPI meets or exceeds these requirements under the noted conditions.

Timing symbols refer to [Figure 3-2](#).

Table 3-5. SPI Timing Parameters

Symbol	Parameter	Condition	Min.	Typ.	Max.	Units
SCK	Slave Frequency supported	$C_{OUT}=10pF$ $C_{OUT}=20pF$			11	MHz
15	SCK falling to MISO Delay ($t_{SCKfalling}$)	$C_{OUT}=10pF$ $C_{OUT}=20pF$			40	ns
13	MOSI Setup time before SCK rises ($t_{MOSIsetup}$)	$C_{OUT}=10pF$ $C_{OUT}=20pF$	10			ns
14	MOSI Hold time after SCK rises ($t_{MOSIhold}$)	$C_{OUT}=10pF$ $C_{OUT}=20pF$	10			ns
9	\overline{SS} asserted to MISO time (t_{SSMISO})	$C_{OUT}=10pF$ $C_{OUT}=20pF$			6	μs
10	SCK period (t_{SCK})	$C_{OUT}=10pF$ $C_{OUT}=20pF$	10			ns
12	SCK Rise / Fall time ($t_{r/f}$)	$C_{OUT}=10pF$ $C_{OUT}=20pF$	10			ns
11	SCK High / Low Period ($t_{highSCK}$)	$C_{OUT}=10pF$ $C_{OUT}=20pF$	15			ns
16	SCK Falling to \overline{SS} Rising	$C_{OUT}=10pF$ $C_{OUT}=20pF$	10			ns
17	\overline{SS} high to tri-state	$C_{OUT}=10pF$ $C_{OUT}=20pF$	10			ns



Figure 3-2. SPI Timings chronograms

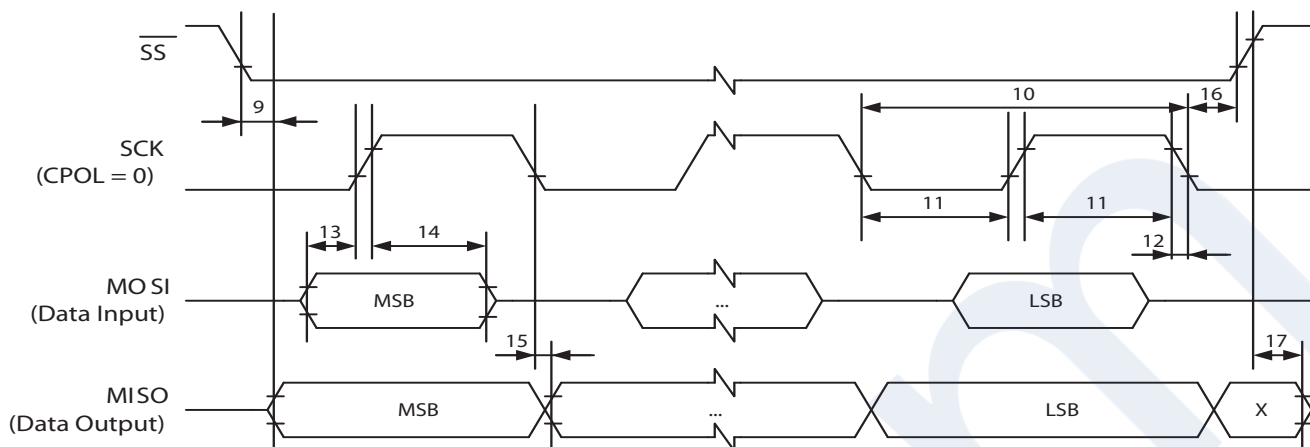

Note

These timings refer to Hardware communication parameters. For protocol timings, please refer to the document *VaultIC408 1.x.x Technical Datasheet*.

3.4 Connections for Typical Application

Figure 3-3. VaultIC408 1.x.x connections for typical I²C application

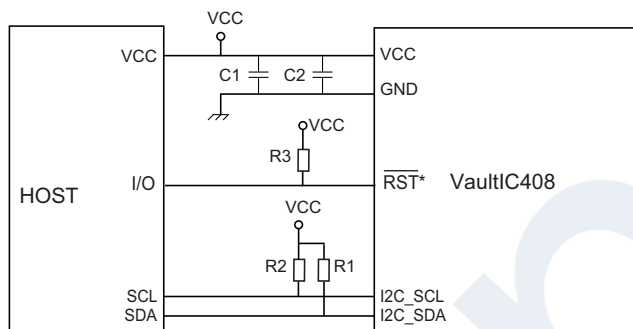

* : Reset pin availability depends on package type

Figure 3-4. VaultIC408 1.x.x connections for typical SPI application

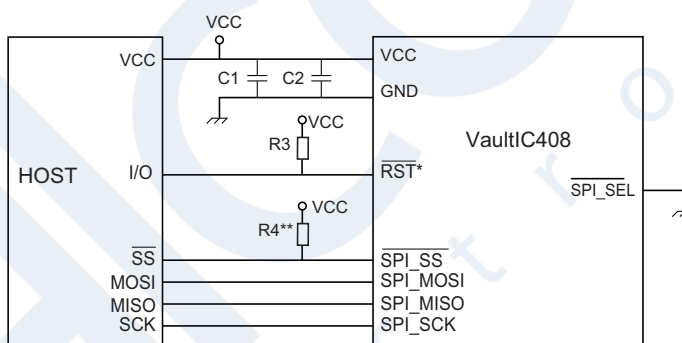

* : Reset pin availability depends on package type
 ** : Mandatory in non legacy package

Table 3-6. External components, Bill of Materials

Configuration	Reference	Description	Typ. Value	Comment
I ² C	R1, R2	Pull-Up Resistors	2.2 k Ω	Recommended
	R3	Pull-Up Resistor	10 k Ω	Recommended
	C1	Power Supply Decoupling Capacitor	4.7 μ F	Recommended
	C2	Power Supply Decoupling Capacitor	10 nF	Recommended
SPI	R3, R4	Pull-Up Resistors	10 k Ω	Recommended
	C1	Power Supply Decoupling Capacitor	4.7 μ F	Recommended
	C2	Power Supply Decoupling Capacitor	10 nF	Recommended

3.5 Pin & Package Configuration

3.5.1 Pin Configuration

Table 3-7. Pin List Configuration

Designation	QFN20	SOIC8	SOIC8 Legacy	Description
SPI_SCK	16	5	5	SPI clock
$\overline{\text{RST}}$	3	6		Reset
VCC	5	7	7	Power supply
SPI_MISO	6	8	8	SPI Master Input Slave Output
SPI_MOSI	10	1	1	SPI Master Output Slave Input
GND	11	2	2	Ground (reference voltage)
$\overline{\text{SPI_SS}}$ / I2C_SCL	14	3	3	SPI Slave Select or I ² C SCL
$\overline{\text{SPI_SEL}}$ / I2C_SDA	12	4	4	SPI/I ² C selection PIN or I ² C SDA
DNC	13			Do Not Connect
DNC	15			Do Not Connect

DNC = Do Not Connect => the pin SHALL be left floating

Other pins are Not Internally Connected => the pin can be freely left floating, or connected to GND, or connected to VCC

3.5.2 Pinouts for packages QFN20 and SOIC8

Figure 3-5. Pinout VaultIC408 1.x.x - Package SOIC8 Legacy - SPI and I²C configurations

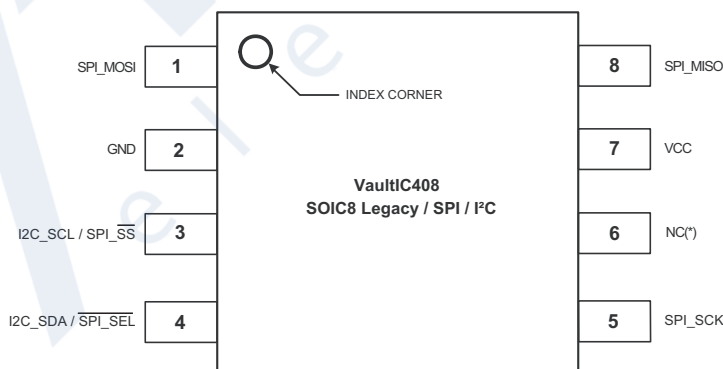

* Not Connected => the pin can be freely left floating, or connected to GND, or connected to VCC

Note : Not Recommended for New Designs.



Figure 3-6. Pinout VaultIC408 1.x.x - Package SOIC8 - SPI and I²C configurations

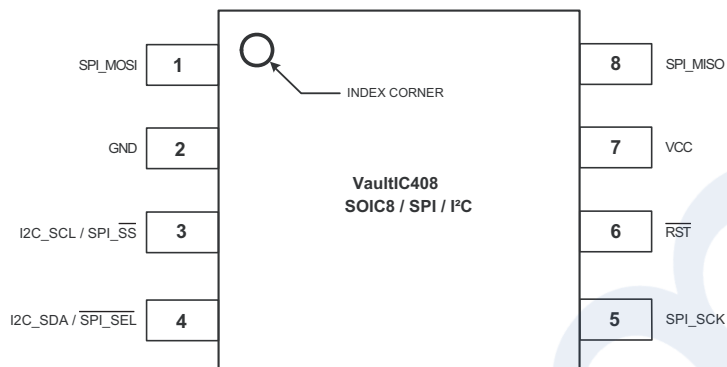
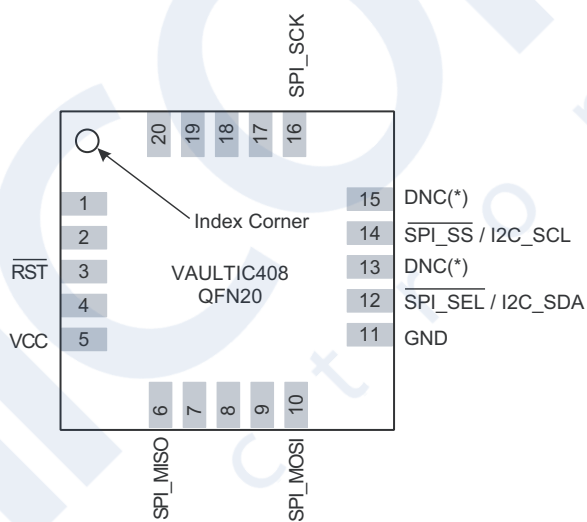

Figure 3-7. Pinout VaultIC408 1.x.x - Package QFN20



* DNC = Do Not Connect => the pin SHALL be left floating
Other pins are Not Internally Connected

3.5.3 Packages characteristics

Figure 3-8. SOIC8 package characteristics

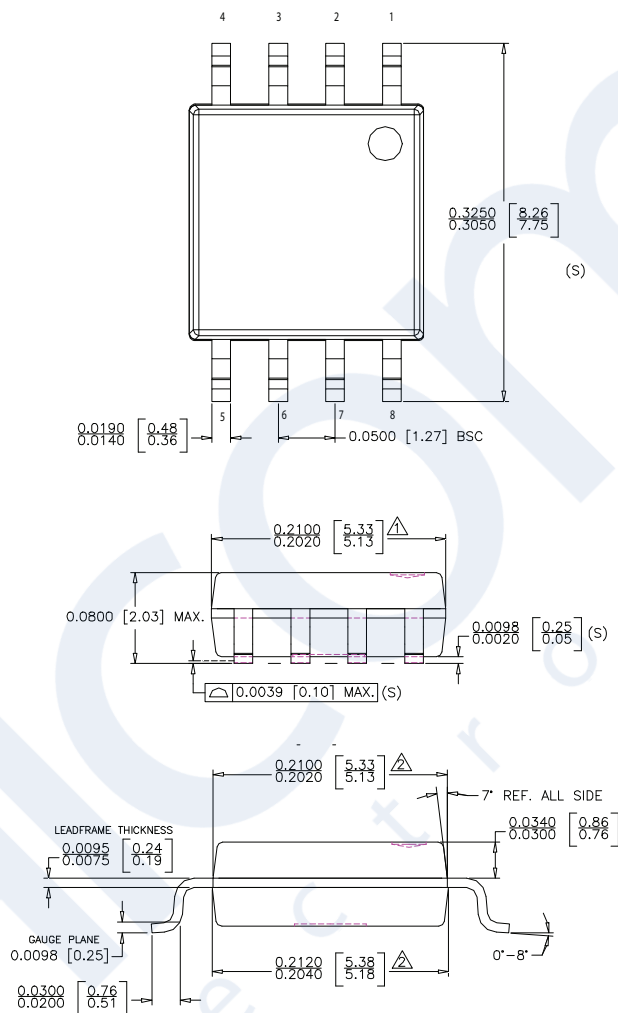

NOTE :

1. DOES NOT INCLUDE MOLD FLASH, PROTRUSIONS OR GATE BURRS. MOLD FLASH, PROTRUSIONS AND GATE BURRS SHALL NOT EXCEED 0.006 INCH PER SIDE.
2. DOES NOT INCLUDE INTER-LEAD FLASH OR PROTRUSIONS. INTER-LEAD FLASH AND PROTRUSIONS SHALL NOT EXCEED 0.010 INCH PER SIDE.
3. THIS PART IS COMPLIANT WITH EIAJ SPECIFICATION EDR-7320.
4. LEAD SPAN/STAND OFF HEIGHT/COPLANARITY ARE CONSIDERED AS SPECIAL CHARACTERISTIC.(S)
5. CONTROLLING DIMENSIONS IN INCHES. [mm]



Figure 3-9. QFN20 package characteristics

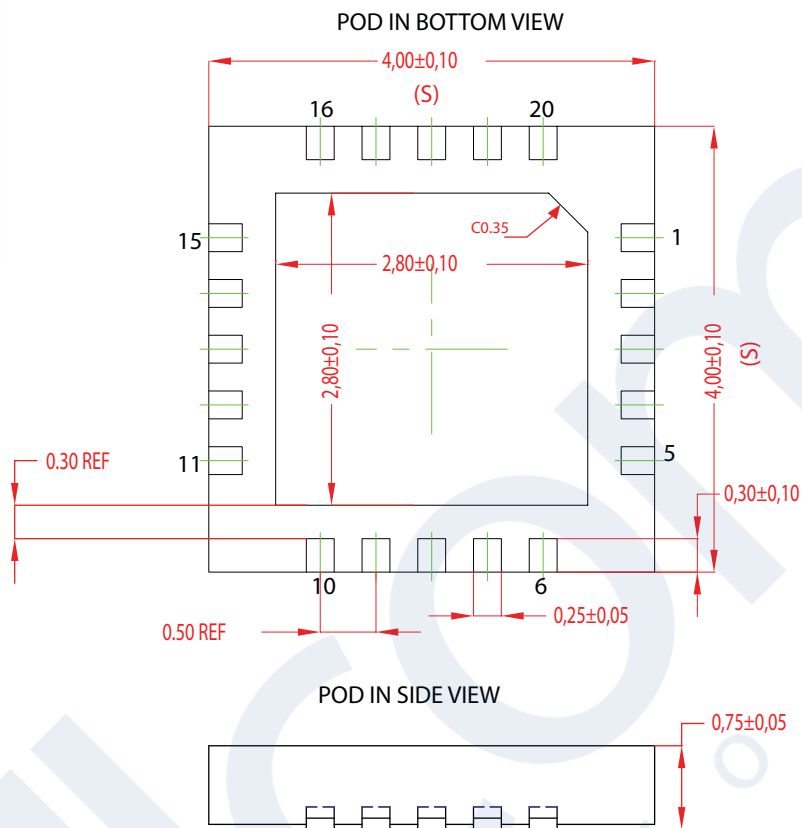

NOTES:

1. ALL DIMENSIONS ARE IN mm. ANGLES IN DEGREES
2. COPLANARITY APPLIES TO THE EXPOSED PAD AS WELL AS THE TERMINALS. COPLANARITY SHALL NOT EXCEED 0.08 mm.
3. WARPAGE SHALL NOT EXCEED 0.10 mm.
4. PACKAGE LENGTH/ PACKAGE WIDTH ARE CONSIDERED AS SPECIAL CHARACTERISTIC.(S)
5. REFER JEDEC MO-220.



3.6 Product Marking

3.6.1 SOIC8 Legacy Package



VaultIC versioning
XXXXXXXX : Lot Number
YYWW : Date Code

3.6.2 SOIC8 Package



VaultIC versioning
XXXXXXXX : Lot Number
YYWW : Date Code

3.6.3 QFN20 Package



VaultIC versioning
XXXXXX : Lot Number
YYWW : Date Code

The photographs and information contained in this document are not contractual and may be changed without notice. Brand and product names may be registered trademarks or trademarks of their respective holders.

Note: This is a summary document. A complete document will be available under NDA. For more information, please contact your local WiseKey sales office.