

Low-Noise, Low-Drift, Precision Voltage Reference

Features

- Wide Input Voltage Range:
 - 7.5 V to 15 V
- Fixed Output Voltage:
 - 2.048 V, 2.5 V, 3 V, 3.3 V, 4.096 V, 5 V and 10 V
- Low Temperature Coefficient:
 - 2.5 ppm/°C Typical from 0°C to 70°C
 - 1 ppm/°C Typical from -40°C to 125°C
- High Initial Accuracy:
 - 0.05% Maximum
- Low Noise:
 - 1 μ Vpp/V
- Temperature Range: -40°C to 125°C
- Package: SOP8

Applications

- Battery Test Equipment
- Industry Control
- Precision Instrumentation
- Medical Equipment

Description

The TPR70 series is a family of high-precision and low-temperature-drift voltage references with the accuracy of 0.05%, and the temperature coefficient of 1.5 ppm/°C. All products of the TPR70 series are able to support both sinking and sourcing current of ± 10 mA and have a low dropout voltage.

The high precision and excellent temperature stability performance make the TPR70 series an ideal reference in the system with high resolution requirement.

The TPR70 series provides a 8-pin SOP package. All the products are qualified to operate with the temperature range from -40°C to +125°C.

Typical Application Circuit

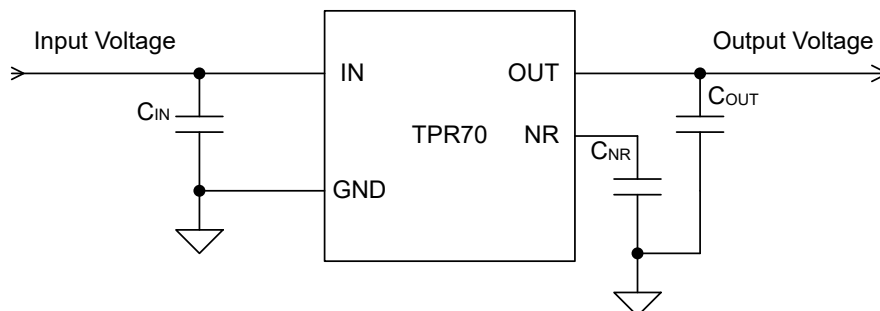

Table of Contents

Features	1
Applications	1
Description	1
Typical Application Circuit	1
Product Family Table	3
Revision History	3
Pin Configuration and Functions	4
Specifications	5
Absolute Maximum Ratings ⁽¹⁾	5
ESD, Electrostatic Discharge Protection.....	5
Recommended Operating Conditions.....	5
Thermal Information.....	5
Electrical Characteristics.....	6
Typical Performance Characteristics.....	8
Detailed Description	10
Overview.....	10
Functional Block Diagram.....	10
Feature Description.....	10
Application and Implementation	12
Application Information	12
Typical Application.....	12
Layout	13
Layout Guideline.....	13
Layout Example.....	13
Tape and Reel Information	14
Package Outline Dimensions	16
SOP8.....	16
Order Information	17
IMPORTANT NOTICE AND DISCLAIMER	18

Product Family Table

Order Number	Output Voltage	Package
TPR7020-SO1R ⁽¹⁾	2.048 V	SOP8
TPR7025-SO1R	2.5 V	SOP8
TPR7030-SO1R ⁽¹⁾	3.0 V	SOP8
TPR7033-SO1R ⁽¹⁾	3.3 V	SOP8
TPR7040-SO1R	4.096 V	SOP8
TPR7050-SO1R	5.0 V	SOP8
TPR70A0-SO1R	10.0 V	SOP8

(1) Preview

Revision History

Date	Revision	Notes
2023-07-15	Rev.Pre.0	Preliminary revision.
2023-12-10	Rev.A.0	Initial released.
2024-05-17	Rev.A.1	1. Added 10.0 V Output Voltage Option 2. Corrected Marking Information in Order Information

Pin Configuration and Functions

TPR70 Series
SOP8 Package
Top View

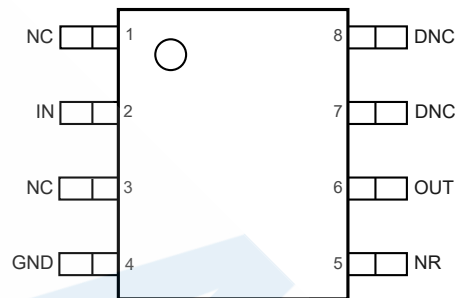

Table 1. Pin Functions: TPR70

Pin No.	Pin Name	I/O	Description
7, 8	DNC	–	Do not connect. Left this pin open or connected to the ground.
4	GND	–	Ground.
2	IN	I	Supply voltage input pin.
1, 3	NC	–	No internal connection.
5	NR/TR	I	Noise reduction pin. A 10-nF or larger capacitor from NR to GND (as close as possible to NR pin) is recommended to minimize the output noise level.
6	OUT	O	Reference voltage output pin.

Low-Noise, Low-Drift, Precision Voltage Reference

Specifications

Absolute Maximum Ratings ⁽¹⁾

Parameter		Min	Max	Unit
V _{IN}	Supply Voltage	-0.3	20	V
T _J	Maximum Junction Temperature	-40	150	°C
T _A	Operating Temperature Range	-40	125	°C
T _{STG}	Storage Temperature Range	-65	150	°C
T _L	Lead Temperature (Soldering 10 sec)		260	°C

(1) Stresses beyond those listed under Absolute Maximum Ratings may cause permanent damage to the device. Exposure to any Absolute Maximum Rating condition for extended periods may affect device reliability and lifetime.

(2) All voltage values are with respect to ground.

ESD, Electrostatic Discharge Protection

Parameter		Condition	Minimum Level	Unit
HBM	Human Body Model ESD	ANSI/ESDA/JEDEC JS-001 ⁽¹⁾	±2000	V
CDM	Charged Device Model ESD	ANSI/ESDA/JEDEC JS-002 ⁽²⁾	±1500	V

(1) JEDEC document JEP155 states that 500-V HBM allows safe manufacturing with a standard ESD control process.

(2) JEDEC document JEP157 states that 250-V CDM allows safe manufacturing with a standard ESD control process.

Recommended Operating Conditions

Parameter		Min	Typ	Max	Unit
V _{IN}		7.5		15	V
I _{OUT}		-10		10	mA
C _{OUT}		0.1	10	100	μF
T _J	Junction Temperature Range	-40		125	°C

Thermal Information

Package Type	θ _{JA}	θ _{JC,top}	θ _{JB}	θ _{JC,bottom}	Unit
SOP8	115	61	61	64	°C/W

Low-Noise, Low-Drift, Precision Voltage Reference
Electrical Characteristics

 All test condition is at $T_A = 25^\circ\text{C}$. $V_{IN} = 7.5\text{ V}$, $C_{IN} = C_{OUT} = 1\ \mu\text{F}$, unless otherwise noted.

Parameter		Conditions	Min	Typ	Max	Unit
Output Voltage						
V_{OUT}	Output Voltage	TPR7020		2.048		V
		TPR7025		2.5		V
		TPR7030		3		V
		TPR7033		3.3		V
		TPR7040		4.096		V
		TPR7050		5		V
		TPR70A0		10		V
	Initial Accuracy		-0.05%		+0.05%	
Output Noise	$f = 0.1\text{ Hz to }10\text{ Hz}$		1		$\mu\text{V}_{PP}/\text{V}$	
Input Voltage and Current						
V_{IN}	Input Voltage		7.5		15	V
I_Q	Quiescent Current	$T_A = -40^\circ\text{C to }125^\circ\text{C}$		0.6	1.7	mA
Output Voltage Temperature Drift						
TC	Temperature Coefficient	$T_A = 0\text{ to }70^\circ\text{C}$		2.5	5	ppm/ $^\circ\text{C}$
		$T_A = -40^\circ\text{C to }125^\circ\text{C}$		1.5	3	ppm/ $^\circ\text{C}$
Output Regulation						
$\frac{\Delta V_{OUT}}{\Delta V_{IN}}$	Line Regulation	$V_{IN} = 7.5\text{ V to }10\text{ V}$		0.1		ppm/V
		$V_{IN} = 7.5\text{ V to }10\text{ V}$, $T_A = -40^\circ\text{C to }125^\circ\text{C}$	-5		5	ppm/V
$\frac{\Delta V_{OUT}}{\Delta I_{OUT}}$	Load Regulation	$V_{IN} = 7.5\text{ V}$, $-10\text{ mA} < I_{OUT} < 10\text{ mA}$		2.5		ppm/mA
		$V_{IN} = 7.5\text{ V}$, $-10\text{ mA} < I_{OUT} < 10\text{ mA}$, $T_A = -40^\circ\text{C to }125^\circ\text{C}$	-20		20	ppm/mA
Thermal Hysteresis						
THYS	Thermal Hysteresis	Cycle 1 (+25 $^\circ\text{C}$ to +125 $^\circ\text{C}$ to -40 $^\circ\text{C}$ to 25 $^\circ\text{C}$)		24.4		ppm
		Cycle 2 (+25 $^\circ\text{C}$ to +125 $^\circ\text{C}$ to -40 $^\circ\text{C}$ to 25 $^\circ\text{C}$)		2.3		ppm
		Cycle 1 (+25 $^\circ\text{C}$ to +70 $^\circ\text{C}$ to 0 $^\circ\text{C}$ to 25 $^\circ\text{C}$)		10.4		ppm
		Cycle 2 (+25 $^\circ\text{C}$ to +70 $^\circ\text{C}$ to 0 $^\circ\text{C}$ to 25 $^\circ\text{C}$)		2.0		ppm
Long-Term Stability						
LTS	Long-Term Stability	1000 hours		10		ppm
		2000 hours				ppm

Low-Noise, Low-Drift, Precision Voltage Reference

Parameter		Conditions	Min	Typ	Max	Unit
Turn-On Settling Time						
t _{ON}	Turn-on Settling Time	C _{OUT} = 1 μF		100		μs
Capacitive Load						
C _{OUT}			0.1		100	μF

Typical Performance Characteristics

All test conditions: $V_{IN} = 7.5\text{ V}$, $V_{OUT} = 2.5\text{ V}$, $I_{OUT} = 0\text{ mA}$, $C_{IN} = C_{OUT} = 1\text{ }\mu\text{F}$, $T_J = 25^\circ\text{C}$, unless otherwise noted.

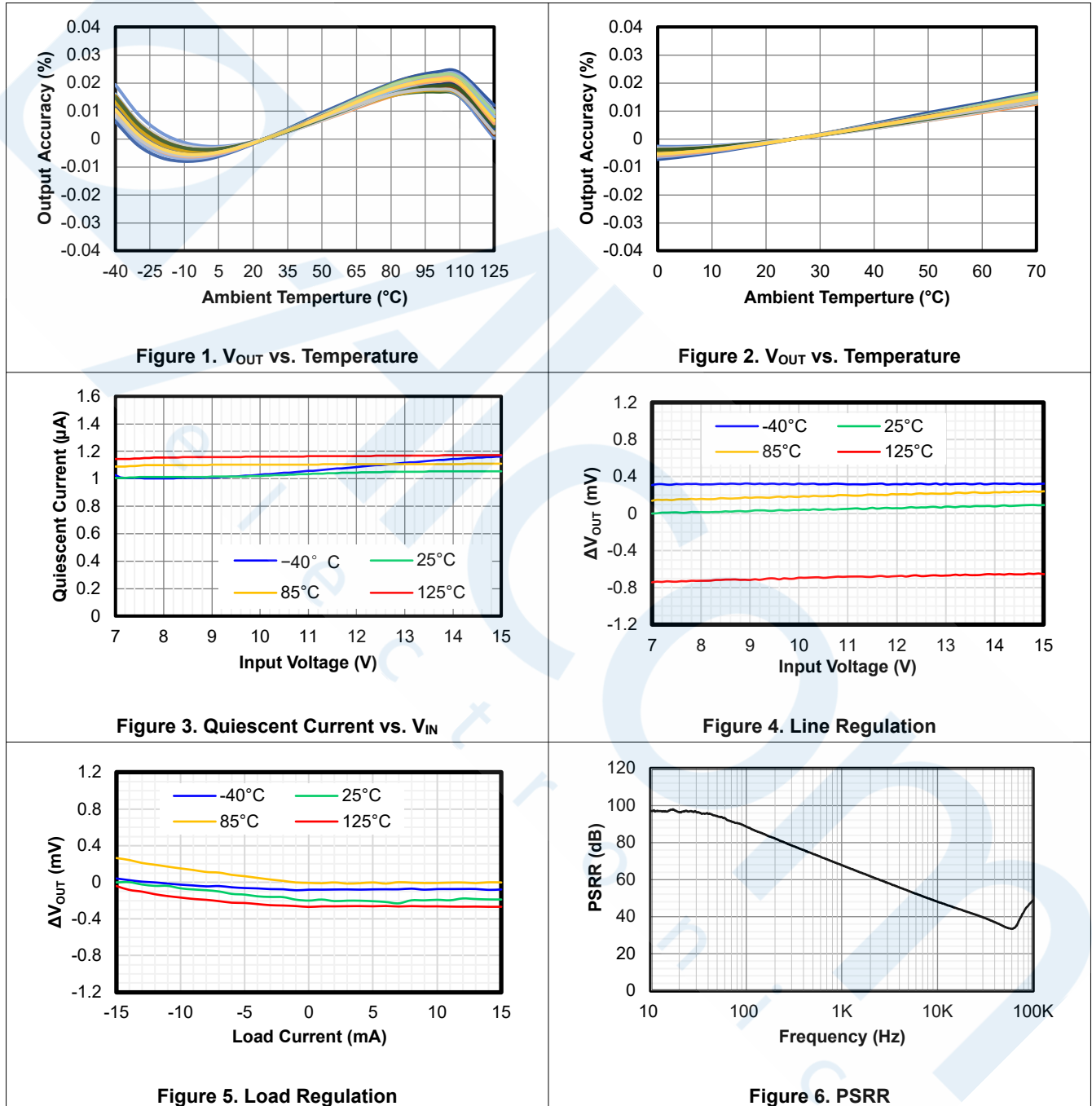

Low-Noise, Low-Drift, Precision Voltage Reference

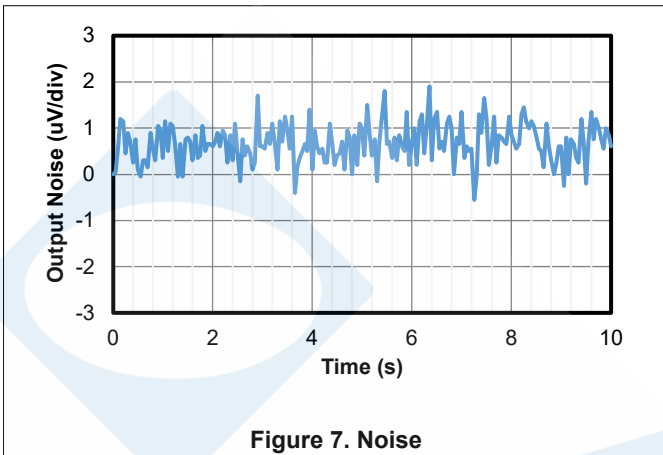

Figure 7. Noise

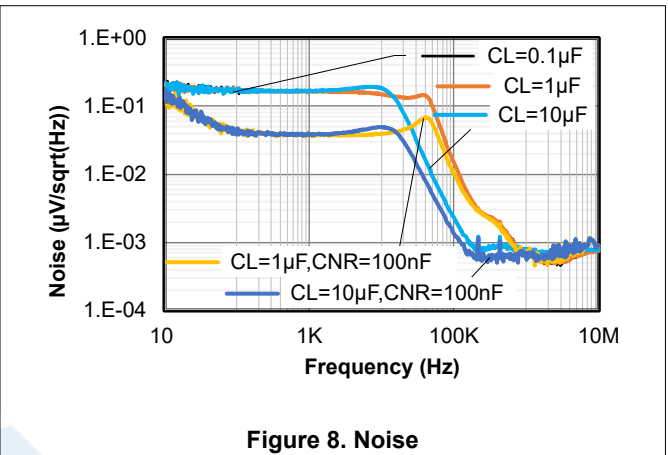
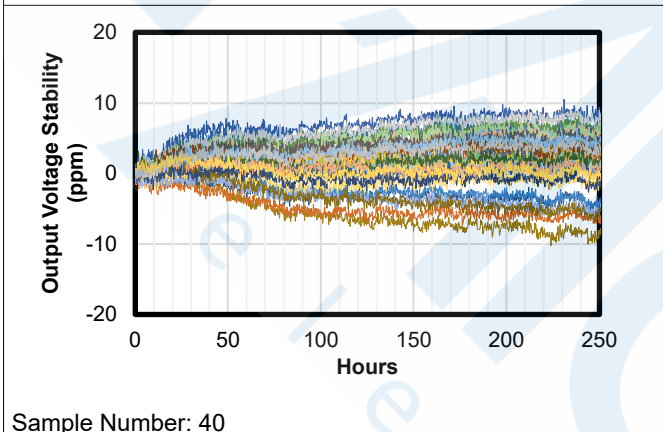
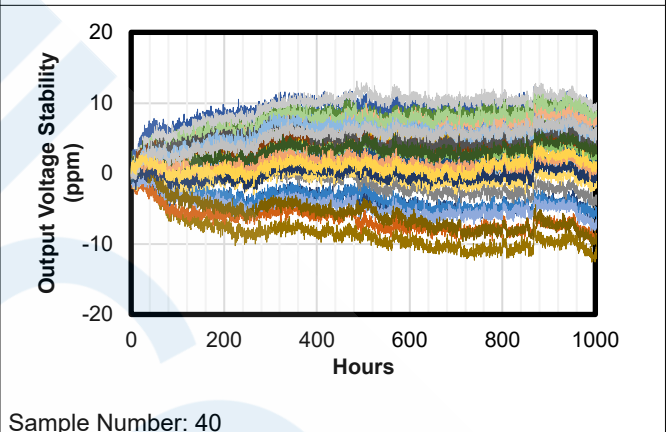

Figure 8. Noise



Sample Number: 40

Figure 9. Long-Term Stability (First 250 Hours)



Sample Number: 40

Figure 10. Long-Term Stability (First 1000 Hours)

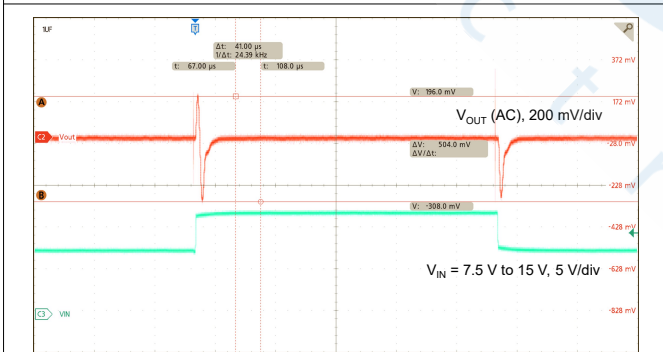

$V_{IN} = 7.5\text{ V to }15\text{ V}$, $C_{OUT} = 1\ \mu\text{F}$

Figure 11. Line Transient

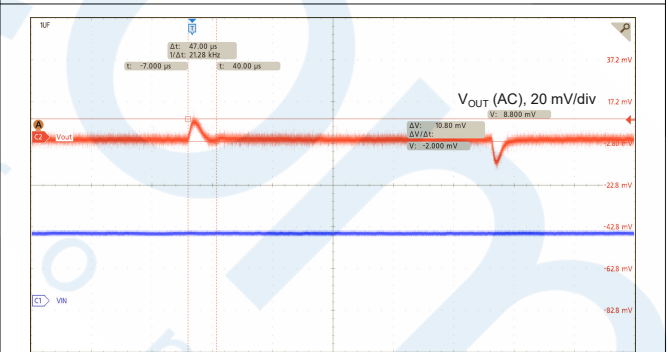

Load = 0 to 10 mA, $C_{OUT} = 1\ \mu\text{F}$

Figure 12. Load Transient

Detailed Description

Overview

The TPR70 series is a family of high-precision and low-temperature-drift voltage references with 0.05% initial accuracy and 1.5 ppm/°C temperature coefficient. All products of the TPR70 series are able to support both sinking and sourcing current of ±10 mA and have a low dropout voltage.

The high precision and excellent temperature stability performance make the TPR70 series an ideal reference in the system with high resolution requirement.

Functional Block Diagram

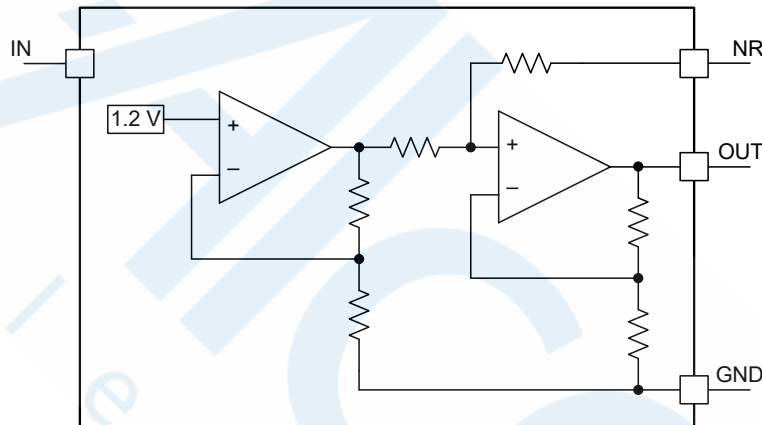

Figure 13. Functional Block Diagram

Feature Description

Temperature Drift

The TPR70 is one of the low-temperature-drift voltage references. Temperature drift is defined as the voltage variation over the operating temperature change, which can be calculated as [Equation 1](#).

$$\text{Temperature Drift} = \left(\frac{V_{\text{OUT,max}} - V_{\text{OUT,min}}}{V_{\text{OUT}}} \right) / (T_{\text{max}} - T_{\text{min}}) \times 10^6 \text{ (ppm/°C)} \quad (1)$$

Where, $V_{\text{OUT,max}}$ and $V_{\text{OUT,min}}$ are the maximum and minimum voltage values during the temperature change, T_{max} and T_{min} are the temperature range, V_{OUT} is the nominal output voltage.

The maximum temperature drift of TPR70 is 3 ppm/°C from -40°C to 125°C.

Thermal Hysteresis

Thermal hysteresis is defined as the voltage change after the operating temperature cycling, which can be calculated as [Equation 2](#).

$$\text{Thermal Hysteresis} = \frac{|V_{\text{PRE}} - V_{\text{POST}}|}{V_{\text{OUT}}} \times 10^6 \text{ (ppm)} \quad (2)$$

Where, V_{PRE} is the output voltage before the temperature cycling and V_{POST} is the output voltage after the temperature cycling, V_{OUT} is the nominal output voltage.

Low-Noise, Low-Drift, Precision Voltage Reference**Noise Reduction**

The TPR70 features a low output noise voltage with a typically value of $2.5 \mu\text{V}_{\text{PP}}$ at $V_{\text{NOM}} = 2.5 \text{ V}$ under room temperature. The noise voltage is proportional to the output voltage and the operating temperature. The noise reduction (NR) pin provides additional filtering to reduce the output noise further. It is recommended to connect a 10-nF or greater capacitor from the NR pin to ground.

Application and Implementation

Note

Information in the following application sections is not part of the 3PEAK's component specification and 3PEAK does not warrant its accuracy or completeness. 3PEAK's customers are responsible for determining suitability of components for their purposes. Customers should validate and test their design implementation to confirm system functionality.

Application Information

The TPR70 series is a family of high-precision and low-temperature-drift voltage references with 0.05% initial accuracy and 1.5 ppm/°C temperature coefficient. All products of the TPR70 series are able to support both sinking and sourcing current of ±10 mA and have a low dropout voltage.

Typical Application

Figure 14 shows the typical application schematic.

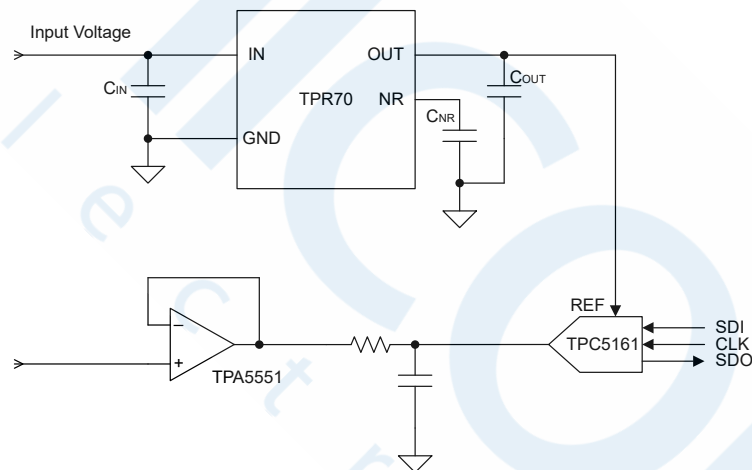

Figure 14. Typical Application Circuit

Power Dissipation and Thermal Consideration

During normal operation, the device junction temperature should meet the requirement in the [Recommended Operating Conditions](#) table. Use below equations to calculate the power dissipation and estimate the junction temperature.

The power dissipation can be calculated using [Equation 3](#).

$$P_D = (V_{IN} - V_{OUT}) \times I_{OUT} + V_{IN} \times I_Q \quad (3)$$

The junction temperature can be estimated using [Equation 4](#). θ_{JA} is the junction-to-ambient thermal resistance.

$$T_J = T_A + P_D \times \theta_{JA} \quad (4)$$

Layout

Layout Guideline

- Both input capacitors and output capacitors must be placed as close to the device pins as possible.
- It is recommended to bypass the IN pin to ground with a 1- μ F to 10- μ F capacitor in parallel with a 0.1- μ F small ceramic capacitor. The loop area formed by the bypass capacitor connection, the IN pin, and the GND pin of the system must be as small as possible.
- It is required to place a decoupling 1- μ F to 50- μ F capacitor at the output. A small 1- μ F ceramic capacitor in parallel is recommended to filter the noise and improve the output transient performance.

Layout Example

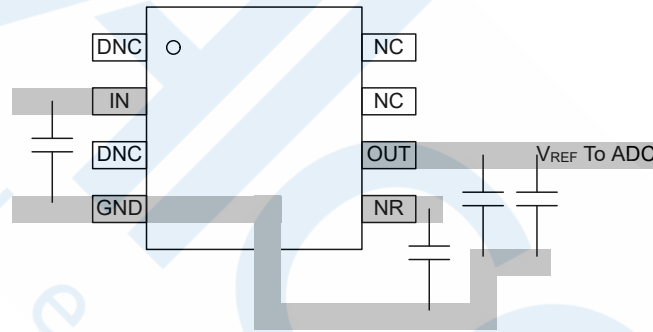
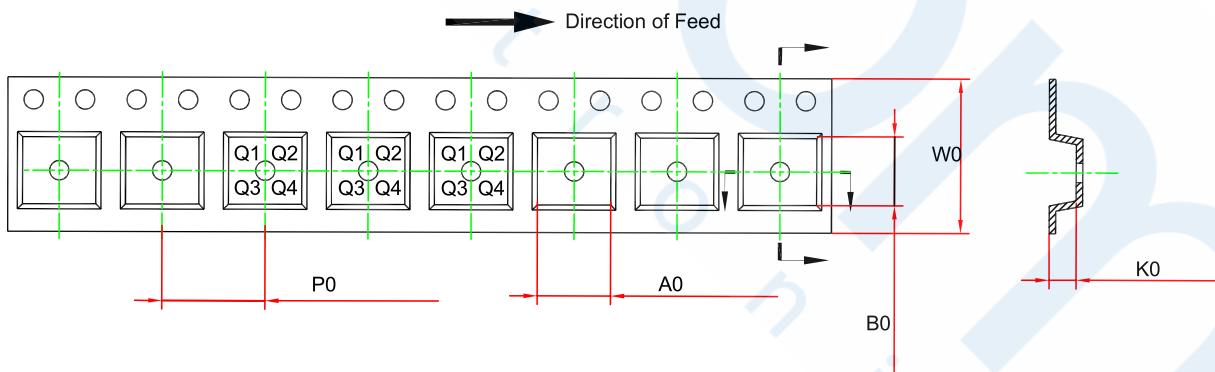
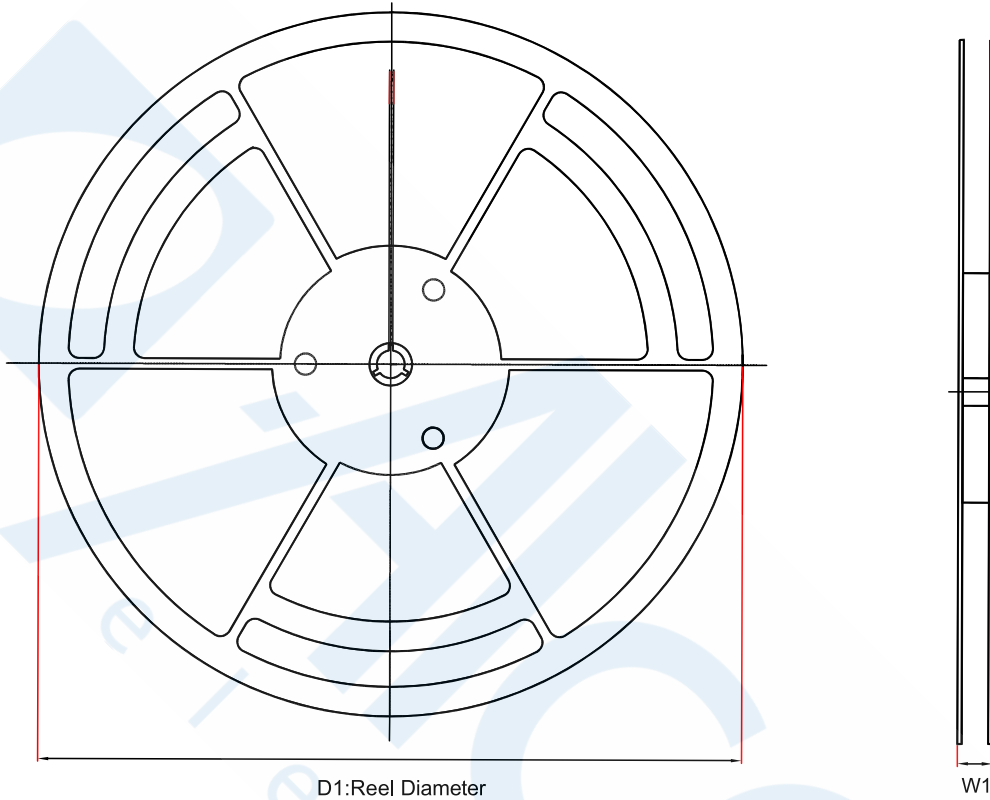

Figure 15. Layout Example

Tape and Reel Information



Order Number	Package	D1 (mm)	W1 (mm)	A0 (mm)	B0 (mm)	K0 (mm)	P0 (mm)	W0 (mm)	Pin1 Quadrant
TPR7020-SO1R	SOP8	330	17.6	6.5	5.4	2	8	12	Q1
TPR7025-SO1R	SOP8	330	17.6	6.5	5.4	2	8	12	Q1
TPR7030-SO1R	SOP8	330	17.6	6.5	5.4	2	8	12	Q1

Low-Noise, Low-Drift, Precision Voltage Reference

Order Number	Package	D1 (mm)	W1 (mm)	A0 (mm)	B0 (mm)	K0 (mm)	P0 (mm)	W0 (mm)	Pin1 Quadrant
TPR7033-SO1R	SOP8	330	17.6	6.5	5.4	2	8	12	Q1
TPR7040-SO1R	SOP8	330	17.6	6.5	5.4	2	8	12	Q1
TPR7050-SO1R	SOP8	330	17.6	6.5	5.4	2	8	12	Q1
TPR70A0-SO1R	SOP8	330	17.6	6.5	5.4	2	8	12	Q1

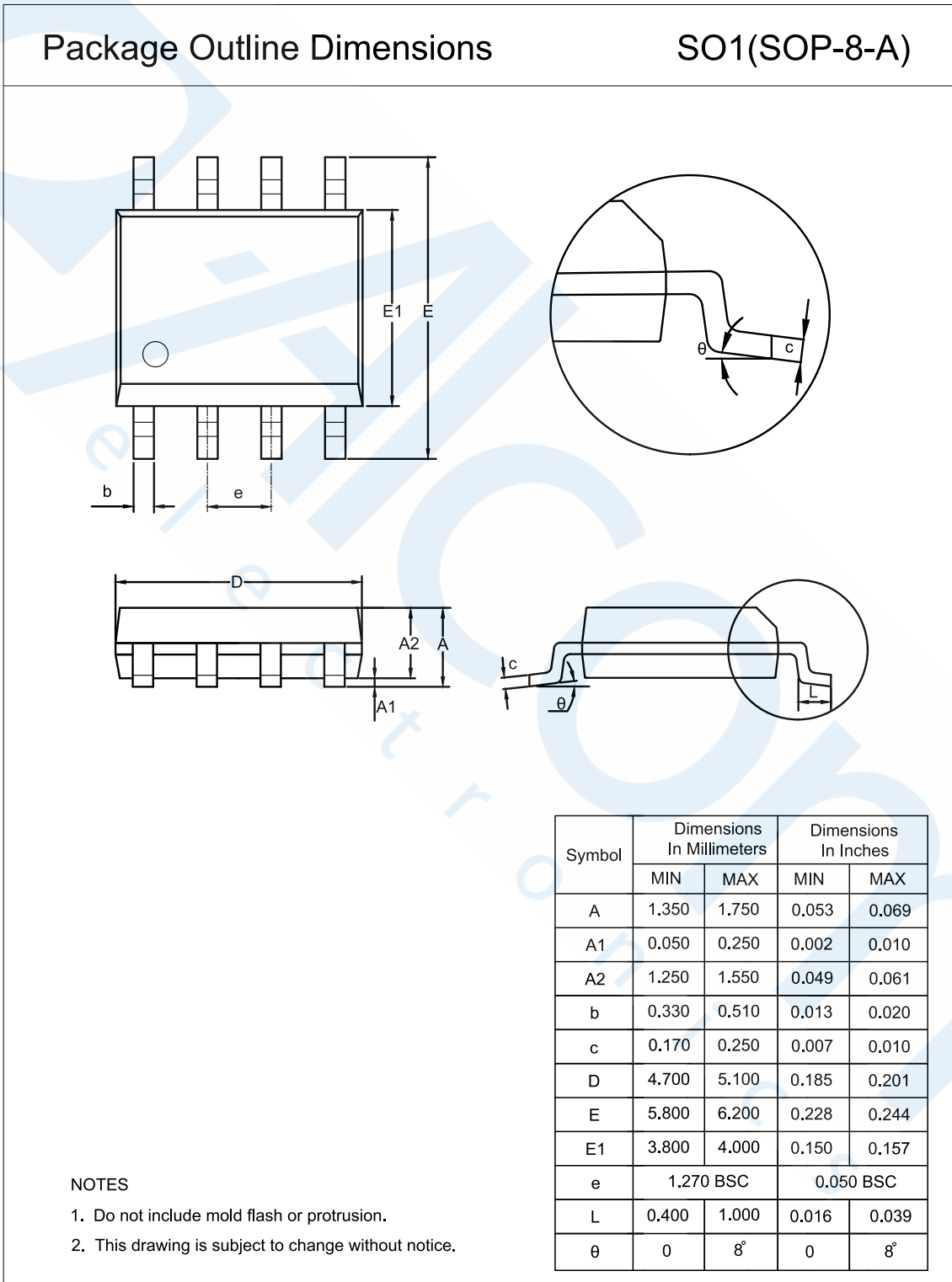
Package Outline Dimensions
SOP8

Order Information

Order Number	Operating Temperature Range	Package	Marking Information	MSL	Transport Media, Quantity	Eco Plan
TPR7020-SO1R ⁽¹⁾	-40°C to +125°C	SOP8	R70B	MSL3	Tape and Reel,4000	Green
TPR7025-SO1R	-40°C to +125°C	SOP8	R70C	MSL3	Tape and Reel,4000	Green
TPR7030-SO1R ⁽¹⁾	-40°C to +125°C	SOP8	R70D	MSL3	Tape and Reel,4000	Green
TPR7033-SO1R ⁽¹⁾	-40°C to +125°C	SOP8	R70E	MSL3	Tape and Reel,4000	Green
TPR7040-SO1R	-40°C to +125°C	SOP8	R70F	MSL3	Tape and Reel,4000	Green
TPR7050-SO1R	-40°C to +125°C	SOP8	R70G	MSL3	Tape and Reel,4000	Green
TPR70A0-SO1R	-40°C to +125°C	SOP8	R70H	MSL3	Tape and Reel,4000	Green

(1) For future products, contact the 3PEAK factory for more information and samples.

(2) **Green:** 3PEAK defines "Green" to mean RoHS compatible and free of halogen substances.

IMPORTANT NOTICE AND DISCLAIMER

Copyright© 3PEAK 2012-2024. All rights reserved.

Trademarks. Any of the 思瑞浦 or 3PEAK trade names, trademarks, graphic marks, and domain names contained in this document /material are the property of 3PEAK. You may NOT reproduce, modify, publish, transmit or distribute any Trademark without the prior written consent of 3PEAK.

Performance Information. Performance tests or performance range contained in this document/material are either results of design simulation or actual tests conducted under designated testing environment. Any variation in testing environment or simulation environment, including but not limited to testing method, testing process or testing temperature, may affect actual performance of the product.

Disclaimer. 3PEAK provides technical and reliability data (including data sheets), design resources (including reference designs), application or other design recommendations, networking tools, security information and other resources "As Is". 3PEAK makes no warranty as to the absence of defects, and makes no warranties of any kind, express or implied, including without limitation, implied warranties as to merchantability, fitness for a particular purpose or non-infringement of any third-party's intellectual property rights. Unless otherwise specified in writing, products supplied by 3PEAK are not designed to be used in any life-threatening scenarios, including critical medical applications, automotive safety-critical systems, aviation, aerospace, or any situations where failure could result in bodily harm, loss of life, or significant property damage. 3PEAK disclaims all liability for any such unauthorized use.