

REV.	DESCRIPTION	DRAWN	DATE
1	INITIAL RELEASE	FROS	2022/03/10

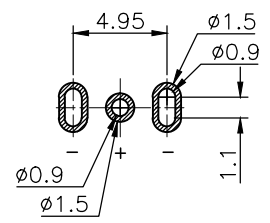
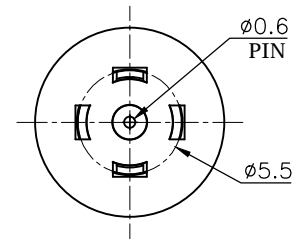
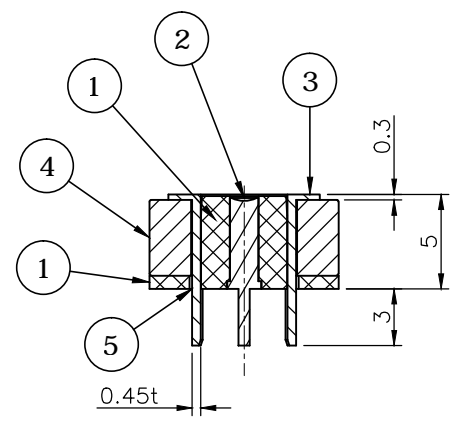
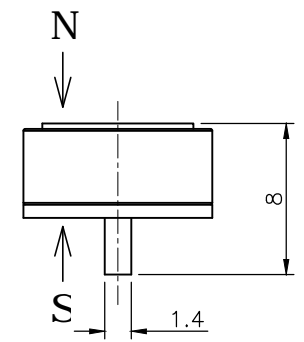
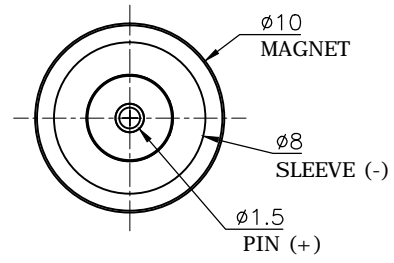

RECOMMENDED LAYOUT
GENERAL TOLERANCE: $\pm 0.05\text{mm}$

SPECIFICATION:

1. Contact Resistance: 100m Ω
2. Operating Temperature Range: -30°C~ +60°C
3. Soldering by manual only

303D-D100M02	3A	12VDC	500g
Match P/N	Current	Voltage	Magnetic Adsorption Force

5	GLUE	LSR-67
4	MAGNET	N35 NdFeB, Nickel plating
3	SLEEVE	Lead Free Brass, Nickel plating
2	PIN	Lead Free Brass, 10u" Gold plating over Nickel
1	HOUSING	HTN, UL94V-0, Black
NO. PART NAME		DESCRIPTION
UNLESS OTHERWISE SPECIFIED TOLERANCE		
UNIT:	SIZE	LINEAR ANGLES
mm	0-6	± 0.1
	6-30	± 0.2
	30-150	± 0.3
		$\pm 2^\circ$
		www.attend.com.tw
DRAWN	Fros	2022/03/10
CHECKED	Tim	2022/03/10
APPROVED	Ken	2022/03/10
DRAWN NAME:		Pogo Pin Magnet Type, Machine Pin 2P, 10.0D, DIP, 10u", 500g, 5A
PRODUCT NO.		303D-D100F02
SCALE	SHEET	SIZE
2.5	1/1	A4
FILE NAME		303D-D100F02_B_1

