



Ruggedness of Connectors

Importance for Application and Processing



What does it mean... Rugged Connectors?

Board-to-Board Connectors can be resistant in many different Ways

Customers often ask for highly 'rugged' connectors, especially when it comes to electronic applications in harsh conditions. This term is particularly common in the aerospace industry, the transport sector, and military and industrial applications. However, there is no 'one size fits all' definition of resistance when it comes to connectors – in fact, the term can be applied to a number of entirely different aspects of connector technology. In this whitepaper, we will explain the most important of these aspects.

Vibration

One of the factors connectors have to deal with and withstand most often is vibration. Vibration can impair the constant, uninterrupted contact that must be maintained between two connectors, or one connector and the PCB. Reliable, stable contact between an SMT connector and the PCB can be achieved using a contact design that is optimized for soldering onto the PCB, for example.

The contact feet on ept's One27 SMT connector are designed to allow an optimum connection to the soldering pads on the PCB during the soldering process. You can tell that a soldered connection is good when a meniscus forms on the solder (see Figure 1). In addition to this, the One27 connector also has a 'board lock' – a metal clip that is also soldered onto the PCB. This anchors the connector firmly on the PCB (see Figure 2). This prevents the connector contacts on the PCB from coming loose when they are subjected to vibration.

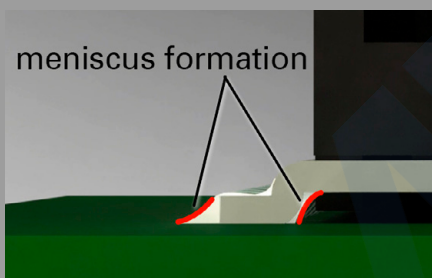

Fig. 1:
The formation of a meniscus on the solder is a sign of a stable soldered connection

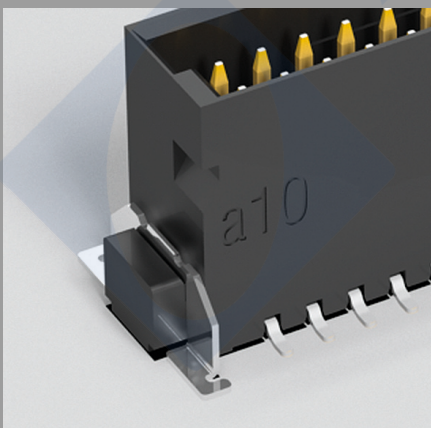

Fig. 2:
The board lock is also soldered onto the PCB

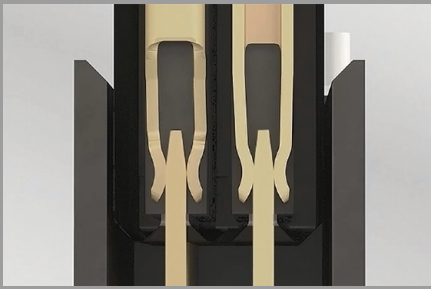

Fig. 3:
Double-sided, flexible female contacts ensure that reliable contact is maintained when a connector is subjected to vibrations



Fig. 4:
Contact is established via the smooth surface of the female contact

Contact between multiple connectors can also be improved using a special design that provides additional stability in case of vibration. This is why the female contact on the ept One27 is flexible and double-sided (see Figure 3). This ensures that there is always at least one female contact touching the male contact, even if the two connectors push up against each other. This prevents the contact from being interrupted in case of vibration. The vibration properties of the One27 connector have been certified for a frequency range of 10–2000 Hz in accordance with the IEC 60068-2-6:2007 standard. The shock properties have been confirmed at an acceleration of 50 G in accordance with IEC 60068-2-27:2008.

Durability

The durability of a connector is usually defined by the number of connection cycles it can complete without any reduction in transmission quality. The most important factor affecting the number of connection cycles is the quality of the plating. High-quality, durable contact coatings reduce the frictional wear on the surface during the connection procedure. Thicker coatings, on the other hand, can take more frictional wear before suffering reduced functionality. In order to reduce friction, of course, it helps if the surfaces of the two contact areas are as smooth as possible. On the One27 connector, this is achieved through the sophisticated design of the female contact, which connects to the smooth, rolled surface of the male contact (see Figure 4). Unlike conventional systems, this prevents contact from occurring on the non-homogeneous, sharp, blanked edge, which would lead to increased frictional wear on the surface.

As a result of this design, One27 connectors possess a Performance Level I classification, which means that they can complete 500 connection cycles, even under harsh conditions such as exposure to corrosive gas (in accordance with IEC 60068-2-60:2015) and frequent fluctuations in temperature (in accordance with IEC 60068-2-30:2005). The relaxation behavior of the female contact remains at the same high level throughout the connector's service life; this has been certified in accordance with IEC 60512-13-2: 2006. The large, rolled contact areas of the female contacts also offer another advantage: higher electrical conductivity. This is the result of the low contact resistance.

Processing & Handling

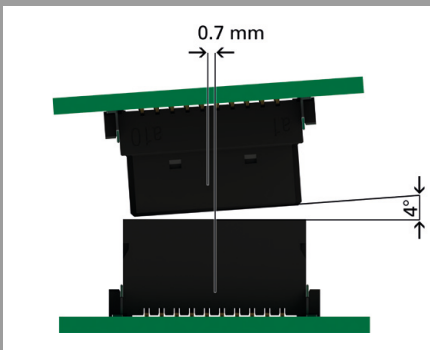

Fig. 5:
The One27 connectors allow generous center and angle offsets during handling

Connectors often need to be as rugged as possible when they are being processed and handled, too. As mentioned above, the board lock soldered onto the PCBs of the One27 connectors absorbs mechanical forces – including those generated when connecting the pairs. The SMT connectors have proven resistant to mechanical loads of up to 400 N in testing.

During the connection process itself, a high tolerance compensation facilitates the handling of the connectors. In this context, the One27 PCB connectors stand out thanks to the combination of the sophisticated contact principle of the double-sided female contact, which encloses the male contact flexibly, and the design of the insulator material. The insulator material on both the male and female contacts has inclined insertion surfaces that compensate for an offset of 0.7 mm in either direction during connection. In addition to this, the capture range also covers longitudinal angles of $\pm 4^\circ$ and transverse angles of $\pm 2^\circ$ (see Figure 5).

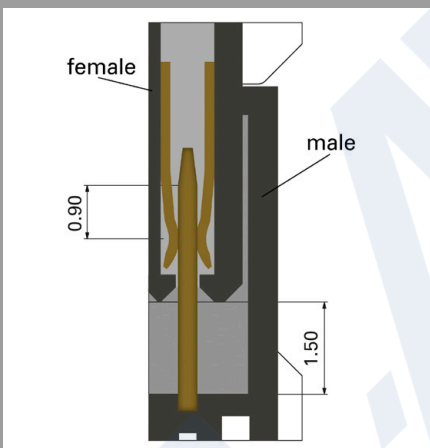

Fig. 6:
Thanks to their high secure mating tolerance, the connectors can be connected at a variety of heights

The double-sided female contact also guarantees that the One27 connectors offer a high secure-mating tolerance: The connection between any male and female connector remains secure up to a distance of 1.5 mm (see Figure 6). Secure mating between the male connector's contact pin and the double-sided spring contact of the female connector is ensured by the remaining 0.9 mm of contact distance. This provides additional versatility when defining board-to-board distances, and also offers high tolerance compensation when connecting two PCBs.

As you can see, there are many reasons that a customer might ask for 'rugged' connectors. As such, it is important for developers to be certain what type of resistance is required for the application at hand. Do the connectors need to be able to absorb mechanical forces during processing, or only during operation later on? Will they be exposed to corrosive ambient conditions? Or will they have to be connected frequently, rather than just once prior to commissioning?

The answers to these questions are crucial in determining what test results are important when choosing the right connectors.

Further information can be found here: www.ept.de/One27

You can watch the animation video for the One27 connector here: <https://youtu.be/k2i09m5eC-E>